

WOOD®

Win a
\$10,000
Dream Shop
Details, p.97

6 Must-Know
Woodshop
Skills p.84

Read This Before
You Buy a
Tablesaw p.62

9 Great Workshop
Projects and Jigs

Make Outdoor
Finishes Last
and Last p.76

BUILD A SUPER-SIMPLE
ROCKER
(IT'S COMFY, TOO!)

plus

- Saw Blade Hanger
- Hall Bench
- Youth Bed



Display until May 13, 2008

\$6.99 U.S.

0 92567 14072 5 0 5 >

in this issue



PROJECTS

- 32 Quick jig: Circular-saw fence gauges**
Get tablesaw precision with your circ saw when you use these simple jigs to set your straightedge.
- 36 Cover project: Classic rocking chair**
- 48 Sized-to-suit shop organizer**
Flexible design lets you build it for six deep drawers, 16 shallow drawers, or some combination between.
- 52 Retro-style knockdown bed**
Perfect for a young adult, this twin-size bed knocks down for storage or for moving out of the nest.
- 66 Basic-Built: Bench with storage**
Craft this handsome, helpful bench using only a few portable power tools.
- 74 Weekend project: Remote control caddy**
- 80 Wall-hung blade storage**

DEPARTMENTS

- 8 Editor's Angle**
- 10 Sounding Board**
- 14 Ask WOOD**
- 20 Shop Tips**
- 116 What's Ahead**

TECHNIQUES

- 26 Durable color finish brightens projects**
- 30 Rout perfect stopped grooves and dadoes**
- 34 Easy tablesaw rabbets**
- 42 How to make dowels and round tenons**
- 70 Turning: Learn to love your skew chisel**
Expert Brian Simmons teaches how to use and properly sharpen this essential spindle-turning tool.
- 76 Prevent and fix outdoor-finish failures**
- 84 Six skills every woodworker should know**
- 94 How to make airtight joints**

TOOLS & MATERIALS

- 44 Tablesaw blades: The new, improved test**
- 62 How to buy a tablesaw**
Learn all about the four types of tablesaws, and see which kind is right for your shop.
- 90 Tool test: Shoulder planes**
Even hard-core power-tool guys love shoulder planes. Find out which one of six tested planes performs best.
- 96 Shop-Proven Products**
Resawing bandsaw, low-cost turning tools, more.
- 104 Wise Buys: Tool-triggered vacuums**



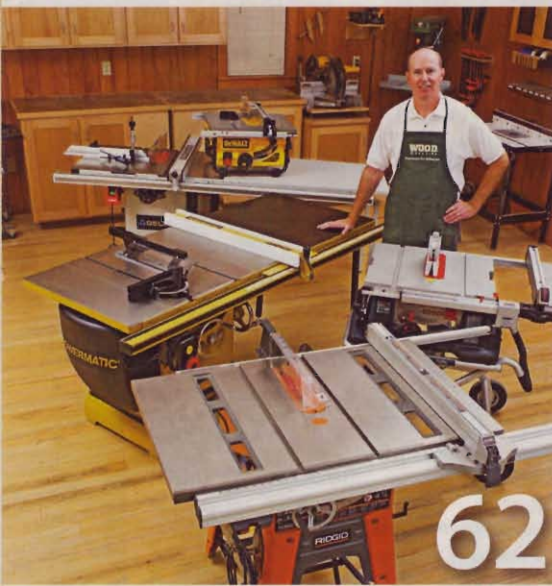

62

WOOD'S MUST-SEE TV

Watch **FREE** videos of the "Six Skills Every Woodworker Should Know" as taught by **WOOD**® magazine editors at woodmagazine.com/basicbuilt.



44

NEW SOFTWARE FORUM A HUGE HIT

Google's free "SketchUp" design software has taken woodworkers by storm!

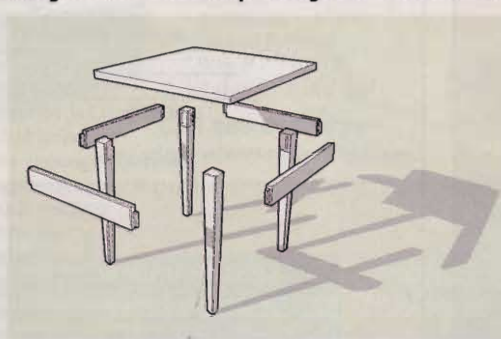

If you have questions about how to use it or other woodworking software, get answers in our "Shop-Savvy Software" forum at woodmagazine.com/forums. You'll also find some excellent tutorials.

MAKE WOOD ONLINE YOUR HOME

Set your browser's home page to woodmagazine.com and every time you launch it, the online world of woodworking opens automatically. It's quick and easy, and we'll show you how at woodmagazine.com/homepage.



MEET "SMITTY"

Reid Smith (aka "Smitty" in the **WOOD Online forums**) built this secretary and documented it with loads of photos. See how the project came together—from rough lumber to finished project—at woodmagazine.com/smittyblog.

This seal is your assurance that we build every project, verify every fact, and test every reviewed tool in our workshop to guarantee your success and complete satisfaction.



26

Bring to Life Each Treasured Story

Each piece of wood has its own story. From its unique lines and contours to the admiring attributes of color and form unfolds a story to be brought to life.



For over 50 years, Old Masters craftsman quality stains and finishes are produced to accentuate wood's natural beauty and provide durability for life's treasured pieces.

Old Masters

Since 1953

Call 800-747-3436
for a FREE product guide or visit
www.oldmasters.biz to locate a
dealer near you.

Proud Sponsor of:
Woodsmith
SHOP

Shown weekly on PBS.

Circle No. 95

Better Homes and Gardens® WOOD®

woodmagazine.com

May 2008

Vol. 25, No. 2

Issue No. 183

We asked our staff:

What tool has been with you since you started woodworking?



I bought two tools in 1975: a Rockwell 1½-hp D-handle router and a Rockwell 7¼" portable circular saw. They're still going strong.

EDITOR-IN-CHIEF
BILL KRIER

Managing Editor
MARLEN KEMMET

Art Director
KARL EHLERS

Techniques Editor
BOB WILSON

Projects Editor
JAN SVEC

Design Editor
JEFF MERTZ

Multimedia Editor
LUCAS PETERS

Production/Office Manager
MARGARET CLOSNER

Deputy Editor
DAVE CAMPBELL

Senior Design Editor
KEVIN BOYLE

Tool & Techniques Editor
BOB HUNTER

Projects Editor
LARRY JOHNSTON

Master Craftsman
CHUCK HEDLUND

Assistant Art Director
CHERYL A. CIBULA

Administrative Assistant
SHERYL MUNYON

Photographers

MARTY BALDWIN, JASON DONNELLY, DEAN SCHOEPPNER, JAY WILDE

Contributing Illustrators TIM CAHILL, LORNA JOHNSON, ROXANNE LeMOINE

Technical Consultant JEFF HALL

Contributing Craftsman JIM HEAVEY

Contributing Proofreaders BABS KLEIN, IRA LACHER, JIM SANDERS

SUBSCRIBER SERVICE

Go to woodmagazine.com/help or write to
WOOD magazine, P.O. Box 37439, Boone, IA 50037-0439

Publisher MARK L. HAGEN

ADVERTISING AND MARKETING

CHICAGO: 333 N. Michigan Ave., Suite 1500, Chicago, IL 60601

Marketing Manager AMANDA SALHOOT

Advertising Managers JACK CHRISTIANSEN, CAROLYN DAKIS

Direct Response Advertising Representative RYAN INTERLAND

Assistants GAYLE CHEJN, NIA WILLIAMS

ATLANTA: Navigate Media

DETROIT: RPM Associates

Product Marketing Manager DIANA WILLITS

Business Manager JEFF STILES

Associate Consumer Marketing Director DAN HOLLAND

Associate Director of Marketing-Newsstand TOM DEERING

Senior Production Manager MELANIE STOLTENBERG

Advertising Operations Manager JIM NELSON

E-Commerce Manager MATT SNYDER

Group Publisher TOM DAVIS

MEREDITH PUBLISHING GROUP

President JACK GRIFFIN

Executive Vice President DOUG OLSON

Editorial Director MIKE LAFAVORE

Finance & Administration MIKE RIGGS

Manufacturing BRUCE HESTON

Consumer Marketing DAVID BALL

Corporate Sales JACK BAMBERGER

Interactive Media LAUREN WIENER

Corporate Marketing NANCY WEBER

Research BRITTA WARE

Chief Technology Officer TINA STEIL

New Media Marketing Services ANDY WILSON



President and Chief Executive Officer STEPHEN M. LACY

Chairman of the Board WILLIAM T. KERR

In Memoriam — E.T. Meredith III (1933–2003)

Our subscribers list is occasionally made available to carefully selected firms whose products may be of interest to you. If you prefer not to receive information from these companies by mail or by phone, please let us know. Send your request along with your mailing label to Magazine Customer Service, P.O. Box 37508, Des Moines, IA 50037-0508.

© Copyright Meredith Corporation 2008. All rights reserved. Printed in the U.S.A.

Retail Sales

Retailers can order copies of WOOD for resale
by e-mailing heather.proctor@meredith.com



Lots of power tools have come and gone, but I still use the trusty old dust-pan I made in high school metal shop.



I purchased a Black & Decker Workmate in college, and 20 years later, it's still as solid as a rock.





WHEN THE SAWDUST SETTLES...

ZAR® finishes on top!

Whether you're creating your own masterpiece or want to give new life to a treasured family heirloom, only the best wood stain will do. ZAR Wood Stain's controlled penetration formula allows you to work at your own pace. ZAR Wood Stain wipes on easily and penetrates evenly for uniform color tone without streaks, lapmarks or blotches. So whether you're a professional or just want professional looking results - use ZAR Wood Stains and Clear Finishes.

You control the stain, It doesn't control you!



For a free brochure and the name of your nearest dealer call 1-800-272-3235, or visit us online at ugl.com.

Circle No. 128

UGL® UNITED GILSONITE LABORATORIES
P.O. BOX 70, SCHWARTZ, PA 18801 • JACKSONVILLE, FL • JACKSON, MS • DAYTON, OH

Editor's Angle

Prototype your way to woodworking success

The next time you build a one-of-a-kind project, you might try assembling a full-size mockup of it first. In the *WOOD*® magazine shop we do this all the time. Here's why.

As I've mentioned before in this column, we design and build in our on-premises shop all of the projects in this magazine. It's the only way to guarantee that those same projects will come together flawlessly in your shop. In building the project, our editors prove every last detail; from the fit of the joinery to the sequence of the directions to the smallest of dimensions.

To further ensure your success, for some projects, such as the Classic Rocker on *page 36*, we even cobble together a prototype out of low-cost materials before we build the version you see in the magazine. It takes a bit of extra time, but the benefits are well worth it. In teaming up to design and build the rocker, staffers Jeff Mertz and Chuck Hedlund constructed a simple prototype from dimensional pine stock (2×4s) to help them determine the following:

- Ideal angle for pitching the chair back. (See photo *above*.)
- Best height and angle for the seat.
- Correct armrest height and angle.
- Front-to-back position of the rockers for a smooth, no-tip motion.
- Height of the top back rail for a comfortable headrest.

During the prototyping process, the chair was held together with screws and clamps for quick and easy adjustments. The prototype joints matched the actual ones to test fit and ease of assembly, though no glue was used to bond them. About \$30 was invested in materials, and making the prototype took about half a day, with another half day to test it on people of various sizes.

By the time Jeff and Chuck finished building the prototype and the actual rocking chair, I was pretty impressed



Before adding the rockers, Jeff (left) and Chuck used shims to establish the ideal angle for pitching the chair back.

with the results. The rocker you see later in this issue is comfortable *and* attractive while attaining a major goal we established in the beginning: It had to be easy to build. And that, perhaps, is its crowning glory, because rocking chairs can be deceptively complicated.

Not this one. We're confident that the vast majority of our readers will be able to build this rocker. It has no tricky compound angles between parts. The joinery is an exercise in simplicity. Parts connect at 90° angles secured with screws, dowels, and round (drilled) mortises. Tenons are routed, not turned. Three identical rails, front and back, ease construction. The curving, comfortable seat doesn't require scooping. And the rockers are each sawn from a single board—no thin-strip laminations required.

All of this was possible because Jeff and Chuck built a simple prototype between the designing and building stages. Way to go guys—well done! 🌲



Bill Krier

Sounding Board

Our bulletin board for letters, comments, and timely updates

No-tangle solution keeps electric cords handy

Thank you for the great Basic-Built Bench-Tool System in issue 179 (October 2007). I built both the upright and mobile base units in a weekend and now have a practical and efficient setup for storing and using my smaller benchtop machines. Because my shop has few electrical outlets, I added extension-cord holders onto my upright cabinet, shown at right, by drilling holes through the stiles and inserting $\frac{3}{8}$ x 5" carriage bolts, with nuts and washers tightened against the stile. Next, I made round "wheels" from leftover pine and threaded them onto the ends of the bolts. Now, my extension cords are always within reach and ready to use.

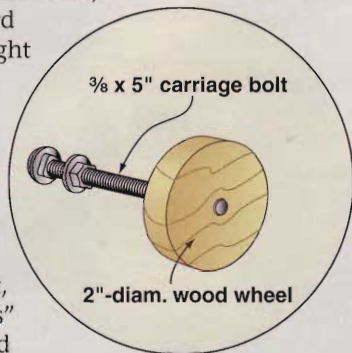

—Todd Janes, Goose Bay, Newfoundland



Can your workshop help inform our readers?

Do you have the kind of shop other woodworkers like to visit? Is your shop filled with clever ideas that help you work smarter, faster, or safer? Have you designed and built special tool racks, machine bases, cabinets, jigs, or other shop helpers you think your fellow woodworkers would find interesting? If so, the editors at *WOOD* magazine invite you to submit your workshop or individual shop projects for review and possible publication in future editions of *America's Best Home Workshops*. Your shop doesn't have to be big or nit-picky clean. The ideas could be storage solutions, task-specific jigs, shop tips, or the special way you designed, built, and outfitted your shop. Mail your entry to *America's Best Home Workshops*, *WOOD* Magazine, 1716 Locust St., LS-221, Des Moines, IA 50309, or go online at woodmagazine.com/homeshops.

—WOOD Editors



But what if there's no shrapnel flying in my shop?

I was elated when I saw the tease on the cover of issue 182 (March 2008) promising "The #1 Secret to Spot-on Accurate Woodworking." I turned immediately to page 80 as the cover instructed, but found an article advising me to avoid shrapnel in my hands. After mulling it over, I realized that, yes, shrapnel in my fingers would definitely affect my woodworking accuracy. How could I have been so blind as to think this was not relevant? Thanks for showing us the light.

—Ryan Moses, Bellevue, Wash.

Ha-ha, Ryan. Obviously, that was our goof. That should have directed you to pages 64–65, where "9 Top Stop Tips" offers advice for accuracy using stops.

—WOOD Editors

Readers take note: Covers vary on *WOOD* magazine

I nearly bought a copy of *WOOD* magazine on the newsstand recently because I knew I had never seen that cover before—although I'm a subscriber. After flipping through it, I realized it contained the same articles inside, just with a different image on the cover. What gives?

—Ken Wright, Medford, Ore.

Sorry for the confusion, Ken. As is common in the magazine industry, we sometimes test multiple covers on the same issue. We do this to get a better idea of which images, headlines, or color schemes resonate best with our readers. To be sure you're not buying a duplicate, check the issue number and month; if those match your copy at home, it's the same issue but with a different cover.

—WOOD Editors

HOW TO REACH US

For woodworking advice:

Post your woodworking questions (joinery, finishing, tools, turning, general woodworking, etc.) on one of 16 online forums at woodmagazine.com/forums.

To contact our editors:

Send your comments via E-mail to woodmail@woodmagazine.com; or write to *WOOD* magazine, 1716 Locust St., LS-221, Des Moines, IA 50309.

Subscription assistance:

To notify us of an address change or to get help with your subscription, visit woodmagazine.com/service. Or write to *WOOD* magazine, PO Box 37439, Boone, IA 50037-0439. Please enclose your address label from a recent magazine issue.

To find past articles:

See our index at woodmagazine.com/index.

Updates to previously published projects:

For an up-to-date listing of changes in dimensions and buying-guide sources from issue 1 through today, go to woodmagazine.com/editorial.

To order past issues and articles:

Order past issues of *WOOD* magazine, our special issues, and downloadable articles from issue 100 to present: Visit our online store at woodmagazine.com/store. Some issues are sold out.

Ask WOOD

Answers to your questions from letters, e-mails, and WOOD Online®

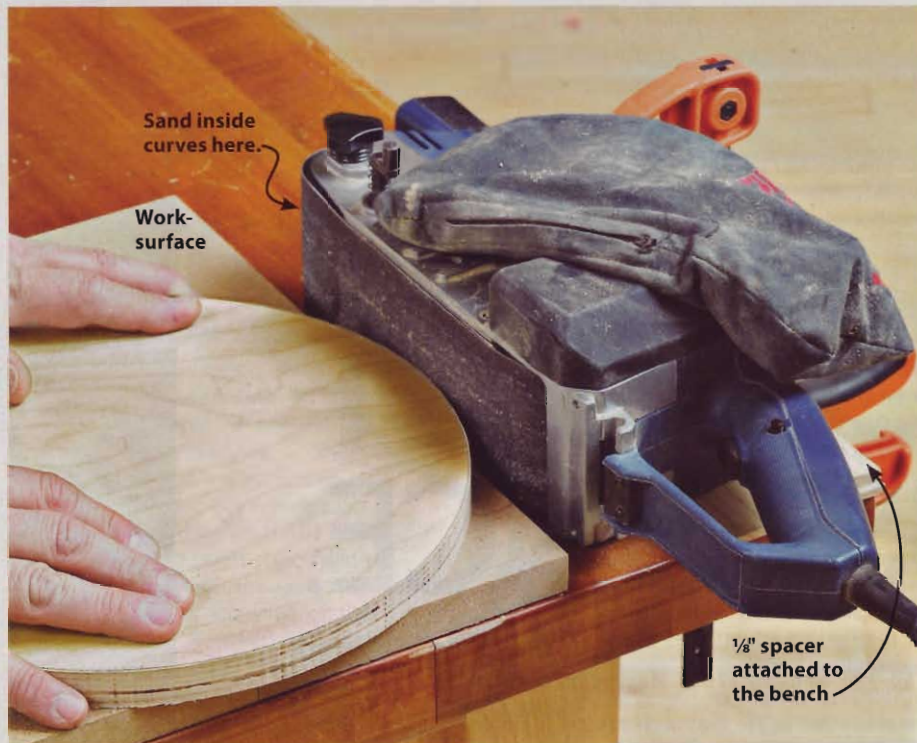

Speed-sand plywood edges

Q: Do you know a technique for smoothing plywood edges? I need to remove fuzzy bandsaw lines without rounding over the edges, and I have a lot of pieces to do.

—Bill Lloyd, Warrenville, Ill.

A: A random-orbit sander makes short work of the straight edges on your workpieces, Bill. Just center the sanding pad on the edge and work slowly to avoid tipping the sander. An oscillating-spindle or disc sander works great on curved edges, but there are ways to do the job if you don't own one of these. Try smoothing rough, curved edges using a belt sander that has one side perpendicular to the platen. Start with 100-grit or 120-grit belts.

To let the belt turn freely, lay the sander on a scrap of 1/8" or 1/4" plywood double-face taped to the bench. Then clamp the sander atop the scrap on the bench. Raise your workpiece by placing it on a scrap of 3/4" plywood or medium-density fiberboard (MDF) double-faced taped to the workbench in front of, but not touching, the sander belt.

For accurate edges, first bandsaw to within 1/8" of your layout line. Then, turn on the belt sander and press the

workpiece against it until you sand the edge down to the line, as shown above. For sanding inside curves, relocate your 3/4" work surface to the sander's front roller. Finish by hand-sanding to at least 120 grit with a rigid block.

You also can sand parts by hand, although it will take much longer. Use the curves on scraps cut from your workpiece to follow the edges, as shown below. Spray-adhere 80-grit through 120-grit sandpaper to the curved scraps, and work the edges down to the marked lines.



HAVE A QUESTION?

For an answer to your woodworking question, write to **ASK WOOD**, 1716 Locust St., LS-221, Des Moines, IA 50309-3023, or e-mail us at askwood@woodmagazine.com. For immediate feedback from your fellow woodworkers, post your questions on one of our woodworking forums at woodmagazine.com/forums.

Keep saw blades from getting that sinking feeling

Q: Sometimes, when cutting grooves or rabbets on my tablesaw, the depth of cut changes by as much as 1/16". I use a shop-made throat plate that's level with the tabletop, and lock the blade height wheel. What's going on?

—Jerry Marshall, Ft. Mohave, Ariz.

A: If you're certain you've made the throat plate level with the saw table, Jerry, the most likely culprit might be backlash from the height adjustment. If you raise the blade and then lower it to the correct height, the arbor assembly can sink slightly as you cut. For consistent cutting depth, first lower the blade beneath your target cutting depth and then raise it to the final position, taking the backlash out of the blade-height-adjustment mechanism. Then lock it in position before making your cuts.



continued on page 16

Ask WOOD

Blue glue clues

Q: I use a lot of redwood, and sometimes the glue squeeze-out leaves a blue stain on my projects. I typically wipe off excess glue with a damp cloth or sponge, so what's causing this staining?

—John Tjoelker, Quincy, Wash.

A: It may be contaminants in the glue or minerals in the wood, John. Blue streaks in redwood can even be caused by dyes or contaminants in the cloth or water you use to wipe away squeeze-out.

Instead of removing excess glue with a damp cloth, allow the squeeze-out to dry



until it forms a firm skin. Then scrape it away with a flat-bladed putty knife, as shown *above*. This way, you eliminate a possible staining source and avoid spreading glue on the wood beside the joint.

Angle tablesaw molding cutters with care

Q: Can you tilt a molding cutter on a tablesaw?

—Nick Herrick, Plain City, Ohio

A: Sure, Nick. In fact, it's a great way to create many profiles from a single set of cutters, as shown *below*. Follow a few cautions, though. First, unplug your saw and mount the molding cutter. Then, tilt the cutter to create the profile you want, judging by the cutter's appearance above the saw table without an insert. Check for clearance by rotating the cutter by hand as you raise and lower it; the cutters may touch some part of the saw even though the cutter body doesn't.

After setting the cutter to the height you want, count the number of cranks it takes to fully lower the cutter. Insert a zero-clearance insert and hold it in place by clamping a piece of scrap to the table over the insert. Plug in the saw, hit the "on" switch, and count the number of cranks to raise the cutter to the desired height to customize the insert, as shown at *bottom*. If you change cutter angles, create a new custom insert.

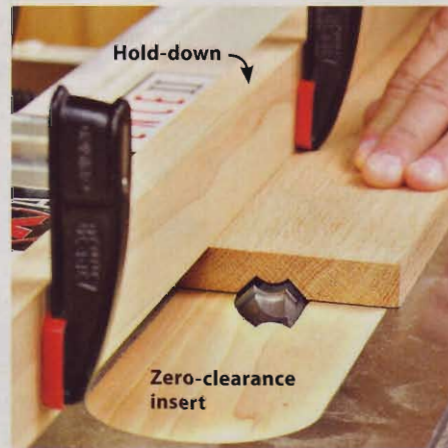

REVOLUTIONARY!



Introducing the new innovative CT50™ Professional Cordless Staple Gun

More than just a sleek, light weight design, this cordless wonder is a rugged, heavy duty staple gun that will appeal to everyone, from the do-it-yourselfer to the professional contractor.

The CT50™ has a light weight 10.8v Lithium-ion battery that guarantees more power, while firing up to 1500 staples on a single charge. Its unique "on-board" battery design maintains perfect balance for increased control and accuracy.

The ultra-bright "LED guide light" will light any

surface with precision positioning of the staple location. The adjustable "depth of drive" control lets you perfectly fire each staple to the desired depth.

Unique to the CT50™, this tool holds two full strips of any of the six Arrow T50® staple sizes saving time on the project.

All this, and more, in a well thought out, ergonomically designed, professional tool that will make any project faster and easier for both the pro and the do-it-yourselfer.



PROFESSIONAL FASTENING
— SINCE 1929 —

Arrow Fastener Co., Inc.

U.S.A. T 201.843.6900 F 201.843.3911
CANADA T 514.321.3983 F 514.321.9424
U.K. T 020.8686.9180 F 020.8686.9197

www.arrowfastener.com

6" dado blades handle most chores

Q: Are there disadvantages to buying a 6" versus an 8" dado set? I have a table saw with a 15-amp motor wired for 110 volts. Some say that 8" blades work okay on such saws; others say to use 6" blades on 110-volt saws. What do I miss by not using 8" blades?

—Loren Nyflot, Richfield, Minn.

A: An 8" blade will give you an extra inch of cutting depth, Loren, but you'll seldom need that capacity for most dados and rabbets. On a table saw in the *WOOD* magazine workshop, we raised a 6" dado stack $1\frac{3}{16}$ " above the table. You'll also spend less on the 6" set: \$210 for the Freud Dial-A-Width dado versus \$240 for the 8"-diameter version at Amazon.com.

The additional teeth on an 8" dado traveling at a higher speed produce a slightly cleaner cut, but that distinction disappears if the added weight slows the saw motor. Your saw's instructions or the manufacturer's Web site should specify the dado blade diameter it can handle. Most 110-volt, 10" contractor-style saws can handle an 8" set, though.

For safety and better cut quality, use a zero-clearance table saw insert, as shown below. You'll find a free video showing how to make one at woodmagazine.com/videos.



Kitchens need a finish that can take the heat

Q: Please recommend a finish to use on maple kitchen cabinet doors. I don't know the existing finish, but it didn't hold up to being splashed with water from the sink.

—Dave Menci, Collegeville, Pa.



A: Few finishes survive frequent contact with water, Dave. And kitchen cabinets also must survive grease and moisture in the air, frequent skin contact around the knobs and pulls, and occasional heat. If you have spray equipment, use a two-part polyurethane, a pre-catalyzed lacquer, or post-catalyzed lacquer.

Otherwise, brush on an oil-based polyurethane thinned about 10 percent with mineral spirits. Apply at least three coats. If you're covering an existing finish, thoroughly clean and scuff it first for a good bond. 🐿

More Power for Your Workshop

Use it once and it will become your favorite woodworking tool!



MEASURE MASTER® PRO

Feet-Inch-Fraction and Metric Dimension Calculator

You'll get professional woodworking results with ease. The Measure Master makes it simple to work in, and convert between, most common dimensional formats – as well as Areas and Volumes. Includes built-in Board-Feet solutions. Model 4020



CONSTRUCTION MASTER® PRO

Advanced Feet-Inch-Fraction Construction-Math Calculator

Our most complete calculator for the advanced woodworker. It features more powerful built-in solutions, in addition to those found in the Measure Master Pro. The perfect tool if your woodworking passion includes projects such as remodeling or adding a room. It even provides Angles for compound miters. Model 4065



HOME PROJECTCALC®

Do-It-Yourself Project Calculator

Simplify your home improvement projects with this easy-to-use calculator. Built-in function keys let you quickly and accurately find material requirements for paint, concrete, tiles, wallpaper and carpet. Model 8510

For the dealer nearest you, call today
1-800-854-8075 or visit...

www.calculated.com



CALCULATED INDUSTRIES®

4840 Hytech Drive Carson City, NV 89706
1-775-885-4900 • Fax: 1-775-885-4949

8 Simple Ways to Trick Out Your DRILL PRESS

Is your drill press up to snuff? It *should* deliver spot-on, hassle-free results across a wide variety of tasks. Check out the helpful tips in this article.

Then, for more pointers, helpful videos, a drill-press speed chart, more information about the accessories shown here, and shop organizer and jig plans, go to woodmagazine.com/trickout. It's all **FREE**.

BROUGHT TO YOU BY



CONSIDER UPGRADING YOUR DRILL PRESS

1

Before you do anything, take a long, hard look at your drill press. Does it expand your woodworking horizons or limit you to basic hole drilling? Some drill presses come pretty tricked out from the factory. For example, the DELTA 17-959L, shown, sports laser crosshairs that tell you the precise center of the hole it will drill. The generous 18×14" table with replaceable insert tilts forward and left or right, enabling you to drill at even compound angles. Adding even more convenience and enjoyment to your shop time: a built-in goose-neck lamp, 17" of swing, and a ¾-hp motor that provides you all the woodworking muscle you'll ever need.

FENCE WITH STOPS



Even the simplest fence—a straight scrap of wood clamped to the table—improves both the accuracy and safety of your drill press. And adding a length stop, such as the one shown on the fence above, fixes the workpiece against two planes for dead-on precision and repeatability. You'll find free and complete plans for this fence and microadjustable stop, plus the versatile add-on tabletop, at woodmagazine.com/trickout.

UTILITY TRAY



Raise your hand if you've never lost a chuck key. This column-mounted Drill Press Utility Tray (DELTA model 17-939) keeps handy items at the ready and swings out of the way when not needed.



Watch two free videos with more on getting the most from your drill press at woodmagazine.com/trickout



MORTISING ATTACHMENT



Dedicated mortising machines are well worth the cost if you're a frequent furniture maker and cut a lot of mortises. If mortising is only an occasional task, though, a drill-press mortising attachment proves to be an effective and economical way to get the job accomplished. The DELTA model 17-924 shown comes with chisels in four common sizes. It fits any drill press with a quill diameter of 66mm, 50.8mm, 48mm, or 38mm.

ADJUSTABLE WORK SUPPORT

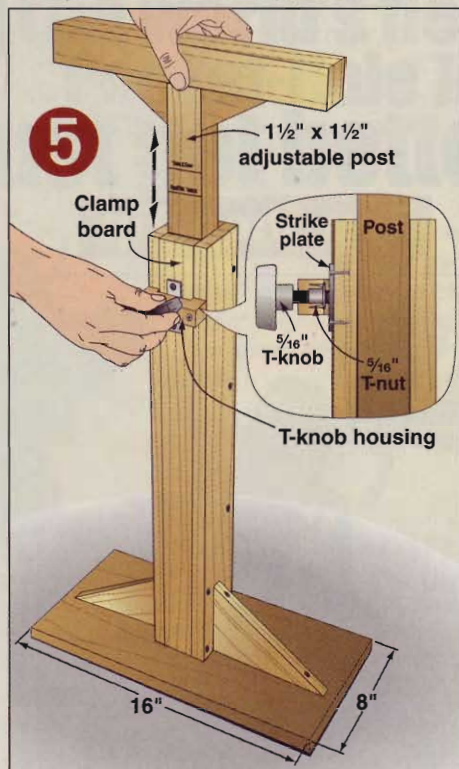

This easy-to-make project provides a helping hand for drilling long workpieces that extend beyond your drill-press table. Make it from any $\frac{3}{4}$ " stock, and mark it with the table heights of other tools—it's great for supporting stock at your miter saw.

DRILL-BIT WALL CABINET

Like many of us, you may find it a challenge to organize all of the drill bits, plug cutters, countersinks, sanding drums, circle cutters, and other accessories that go with a drill press. This cabinet solves that problem, keeping your accessories easy to see and dust-free. The simple-to-make box has a half-lapped door frame with a clear acrylic insert. The one shown measures 2x4', or you can easily resize it to fit your space. Customize the cabinet to suit your changing accessories, or configure it to hold hand tools or various shop supplies. You'll find free and complete plans at woodmagazine.com/trickout.



7 STEP-AND-REPEAT FENCE

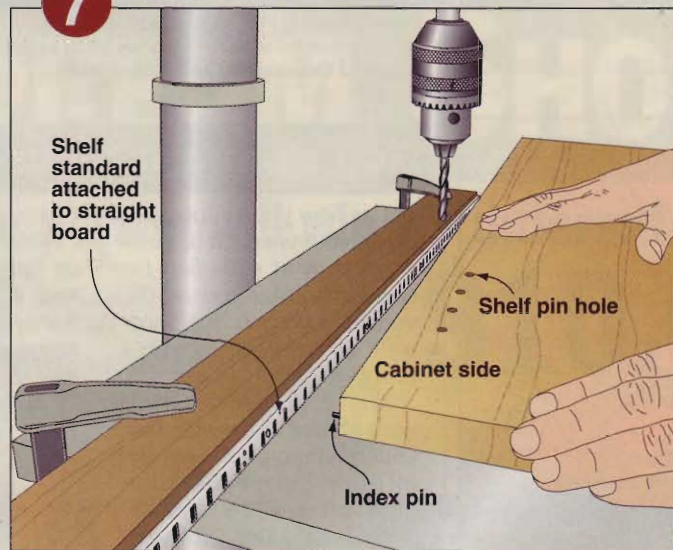

For attractive adjustable shelving, you need to drill identically spaced holes in cabinet sides—these holes hold the pins that support the shelves. To get started, build and attach this fence to your drill-press table. Make an index pin by driving an 8d finish nail into the edge of your cabinet side. Cut off the nail, leaving about $\frac{1}{8}$ " protruding. If you want shelf-pin holes every inch, insert the index pin into one of the slots, drill a hole, move the pin down two slots, drill the next hole, and repeat.

DUST COLLECTION WITH A TWIST



Whether drilling or sanding at your drill press, you'll find the going easier if you collect the chips and dust before they obscure your view of the workpiece, spill onto the floor, or possibly interfere with the accuracy of your fence or stops. This handy shop-made fixture enables you to position a shop-vacuum hose exactly where you need it. You can swing it into position or out of the way by twisting the knobs that lock it to the drill-press column and control the tilt of the hose mount. For free, complete plans, go to woodmagazine.com/trickout.

Shop Tips

Helping you work faster, smarter, and safer

A simple wedge can be very persuasive

Around Christmastime, my lathe becomes a production platform for platters. After trying most of the options for mounting a workpiece to a faceplate, I've decided double-faced turner's tape (Rockler part no. 50492, \$7.49; 800-279-4441, rockler.com) is as close to perfect as it gets. Sometimes, it works too well: I usually have to chisel off the sacrificial faceplate and often mar the underside of the platter.

For a solution, I made a sacrificial faceplate as usual, but I cut a 1/2" dado 3/16" deep through the center before bandsawing it round and screwing it to the lathe's faceplate with the dado facing out. Next, I make a small hardwood wedge that fits into the slot. Then, I use turner's tape to mount the workpiece to the sacrificial faceplate, and turn the platter.

When I'm done, I insert a thin piece of veneer (to protect the workpiece) and the wedge into the dado gap and gently tap in the wedge until the workpiece pops off.

—Doug Green, Marble Falls, Texas

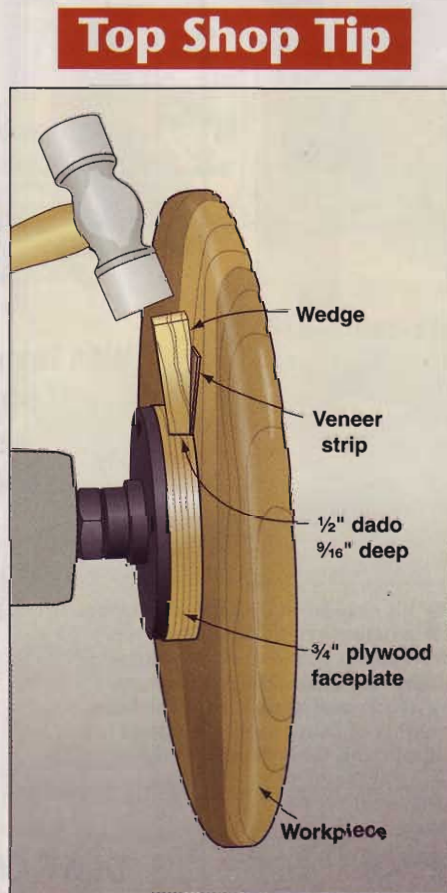

Dip your pushsticks to stymie slippage

Most pushsticks, whether home- or factory-made, tend to slip on wood surfaces. To stop that, dip the tips of your pushsticks in liquid tool-handle coating, such as Plasti Dip (plastidip.com, 800-969-5432). I usually build up several light coats, quickly shaking off the excess material each time. On broad surfaces like pushblocks, I also rough up the face and brush on several coats.

I like to dip the handles, too, for a softer, firmer grip. Using a bright color makes it easier to find a pushstick in the clutter of the shop.

—Pete Johnson, Edgerton, Wis.

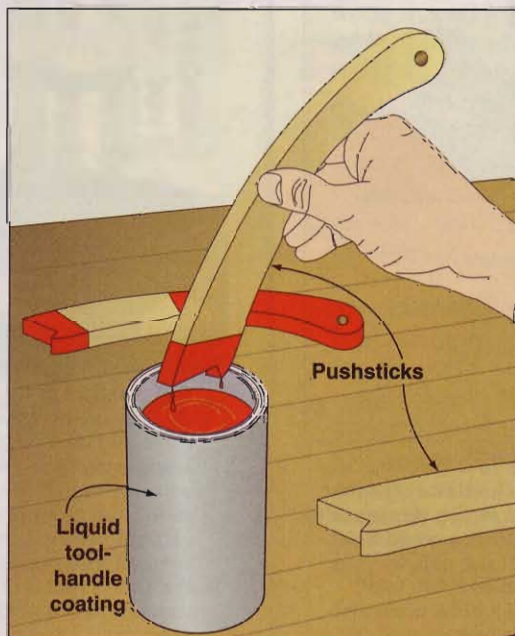

continued on page 22

The Top Tipster



Photo: Ryan Green Photography

Semiretired meat wholesaler Doug Green began hanging out at his local woodworking store so much that he was hired part-time. He spent the remainder of his free time meticulously planning his new shop, which became the envy of his fellow Central Texas Woodturners Association members. "There's not a tool out there that I don't have," he boasts. "There's nothing I can't do if I want to."



Doug's friends will be a darker shade of green when he tops off his shop with Leigh's Super 12 Dovetail Jig and accessories.

Top tips earn tools!

Tell us how you've solved a workshop stumper. If we print it, you'll get \$100 and a copy of 450+ Best-Ever Shop Tips (woodmagazine.com/450tips). And, if your idea garners Top Shop Tip honors, we'll also reward you with a tool prize worth at least \$300.

Send your best ideas, along with photos or drawings and your daytime phone number, to: **Shop Tips, WOOD Magazine, 1716 Locust St., LS-221, Des Moines, IA 50309-3023.** Or, by e-mail: shoptips@woodmagazine.com. Include your contact info in the e-mail.

Because we try to publish original tips, please send your tips only to WOOD® magazine. Sorry, submitted materials can't be returned.



Have a ball completing narrow turned vessels

I really enjoy turning tall, narrow vessels, such as flower vases, on my lathe, but I don't enjoy making a new plywood jam chuck for each different bowl size. (A jam chuck allows me to reverse-chuck the vase and clean up its bottom.) My solution involves a short length of 4" PVC pipe and a few rubber balls of various sizes.

I attach a 5" disc of birch plywood to a faceplate, true up the circumference, and turn a 1/2"-deep rabbet into the faceplate's outer edge so that it fits the inside pipe diameter. Using the tailstock as a clamp, I attach the PVC to the plywood with PVC glue. After it cures, I finish and sand the open end of the pipe to a smooth, rounded edge.

Setting up the jig, ball, vessel, and tailstock is a breeze, as all the components "center out" automatically. Using a prudent speed and a few light passes with a 1/4" bowl gouge, I can easily detail the base of the vase.

—Jim Vasi, Williamsville, N.Y.

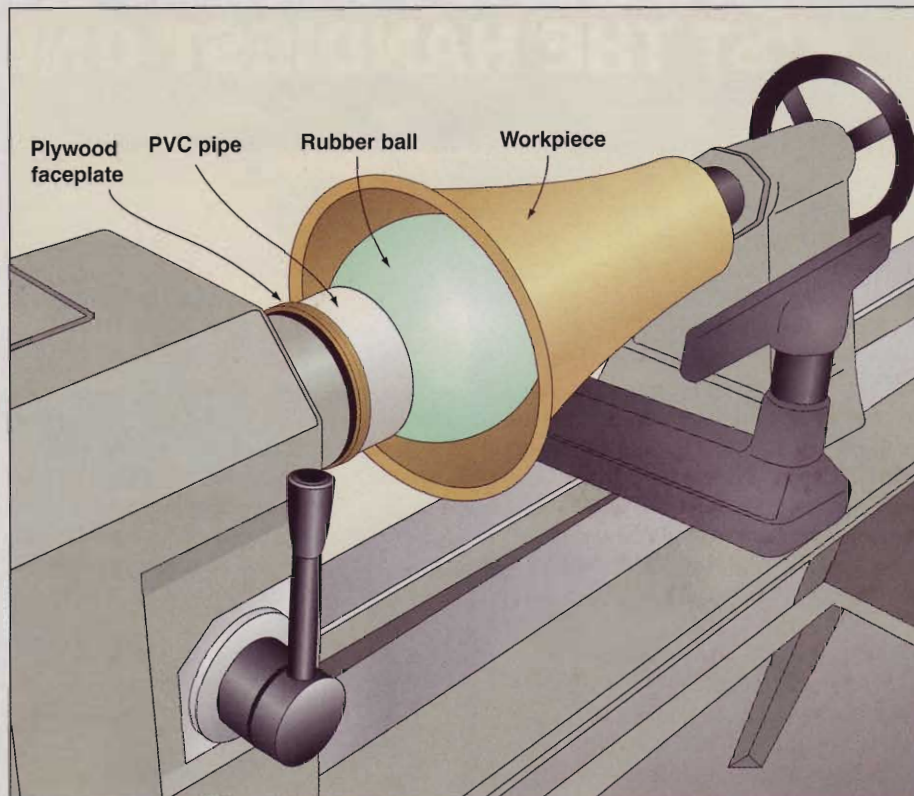

For current promotions, complete product info and a list of dealers near you:
WWW.GENERAL.CA



DUST COLLECTOR 1 1/2 HP

Totally enclosed, fan cooled, permanently lubricated motor. Designed for industrial applications with a continuous duty rating.

Heavy-duty construction, mounted on four swivel casters, allowing total mobility and stability.

Model 10-105 CF M1:
 Same specifications but with 1 micron canister filter (#10-106) replacing filter bag & mounting hardware.

1100 CFM



Mount a tablesaw box-joint jig to your router table

Recently, I built the tablesaw box-joint jig from *WOOD*® magazine issue 108 (also available for purchase at woodmagazine.com/boxjointjig). The jig works great, except I was dissatisfied with the quality of cuts I got with my inexpensive dado set: The outside blades left little "devil ears" on the bottoms of my box-joint cuts. To make more heavenly joints, I retrofitted the jig for use with my router table. Here's how you can do the same.

Begin by building two trap fences about 12" wide out of 1/4" hardboard or scrapwood. These trap fences should be as long as your router table, plus the width of a cleat attached to each trap fence. The cleats align and help secure this false top to your router table. In the bit-side trap fence, make a slightly oversized cutout for the bit because the jig's slide base will need to pass clear of the bit.

Next, make a slide base for the box-joint jig, as shown, center it under the

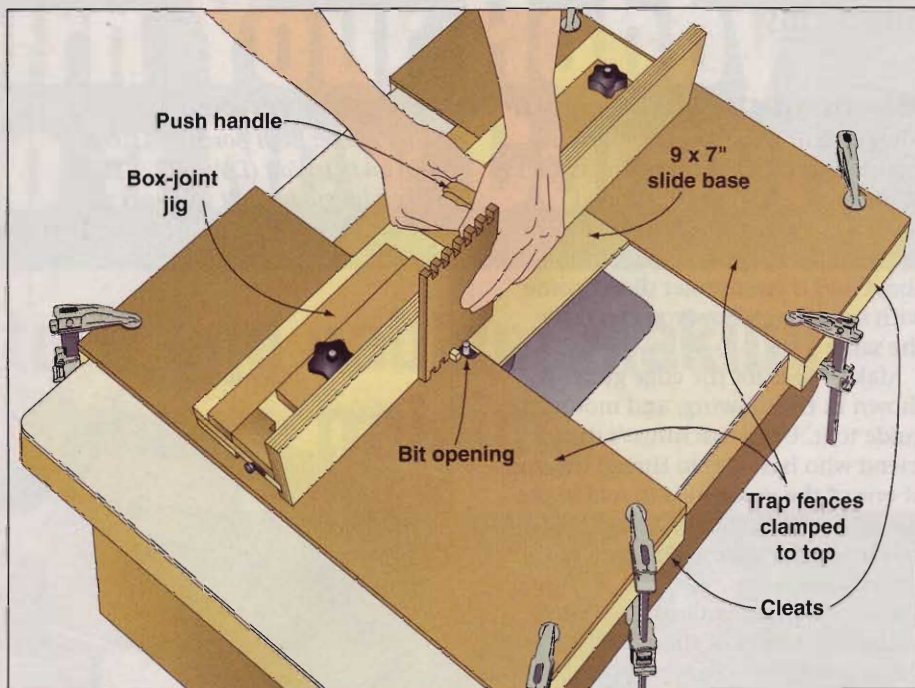

jig's push handle, and screw it to the jig. To reduce friction, seal the slide base with finish and apply a generous coat of paste wax.

Install the trap fences by first clamping the bit-side trap fence in place

on the tabletop. Place the box-joint jig with slide base in the middle of the table, and clamp the second trap fence in place.

—Dominic Greco, Richboro, Pa.
continued on page 24

woodmagazine.com

23

Excalibur
BY GENERAL INTERNATIONAL



OVERARM BLADE COVER SYSTEM

with dust collection capability

4" main boom with telescopic 3" inner boom.

Easy to install & simple to use - connects to standard 4" dust hose.

Maximize dust collection efficiency with any dust collector without compromising safety.

Heavy-duty see-through blade cover with spring loaded swing arm raises & lowers to suit stock thickness.

UNIQUE DESIGN MOUNTING BRACKET: PIVOTS ARM AWAY OR REMOVE COMPLETELY IN SECONDS



Microadjustment for your router-table fence

After building the router-table fence featured in *WOOD* magazine issue 159 (November 2004, p. 40) I added superfine-tuning for the cost of a micro-adjustable router edge guide—about \$40 if your router didn't come with one. Here's how you can do the same.

Make a base for the edge guide, as shown in the drawing, and mount the guide to it. Use a machinist's die (or a friend who has one) to thread the end of one of the guide rods to match the threads on the T-nut on the cleat. Glue and screw the cleat to the back of the router-table fence.

I leave the microadjuster attached to the fence most of the time, but without the base clamped down. When I need to fine-tune a cut, I clamp the base to the tabletop, as shown, and then use the dial on the edge guide to tweak the fence location. When it's dead-on, I lock down the fence and make the cut.

—Dr. Jeffrey Kornblum, Jonesboro, Ark.

Editor's note: Both Bosch (RA1054, \$40) and DeWalt (DW6913, \$35) make edge guides that will work for this tip.

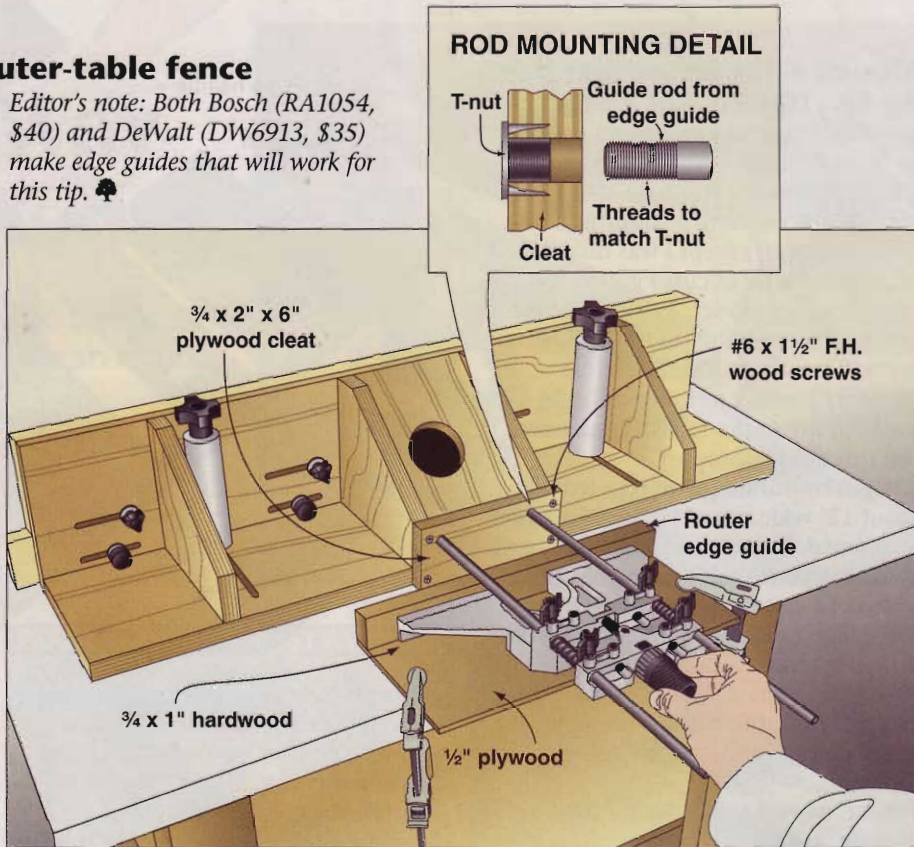

The Experts Have Spoken!



"...with the astonishingly small amount of overspray there's little doubt ... the A7500 is the **BEST HVLP** gun we've seen in a long time."
Popular Woodworking -2007 Best New Tools



Winner of the AWFS Sequoia Award for the most innovative new product.

A7500QT Atomizer Quick-Release Cup Gun with an Apollo HVLP Green Machine Turbine



Order Yours Today
888-900-4857 (HVLP)
www.hvlp.com/w108

Photo Courtesy of Popular Woodworking

Dept. w108

Give Wood a Vivid Finish

Use inexpensive finishing materials to brightly color birch, maple, ash, poplar, or other light-toned woods in a rainbow of tints.



You can colorize wood by using expensive dyes that will fade over time, or you can use this process involving low-cost paint and thinner to achieve a no-fade color burst. It's perfect for fun and functional furniture, like the knock-down bed on page 52, or for kids' toys and bedroom accessories. Buy the ingredients at any hardware store or home center, and apply it quickly and evenly using common painting pads.

Begin by sanding your project parts up to 180 grit. Remove all sanding dust with a vacuum and a clean rag. Then use a vacuum or compressed air to remove any loose fibers from the paint applicator pads. We're applying this finish to a bed designed to be disassembled for moving; for projects you'll glue together, mask the joint areas for a better wood-to-wood glue bond.

To make this finish, mix equal amounts of oil-based enamel paint and mineral spirits [Photo A] in a clean container to create a translucent finish called a toner coat. Different paint colors thin to different shades, so lighten or darken the color as you choose by varying the amount of solvent. Then fill the bottom of a paint tray with thinned finish.

Pad on a coat of color

First, use a large applicator pad, brushing with the grain to cover the surface [Photo B]. Avoid leaving overlap marks or excess finish. Then use a trim pad to coat the edges without leaving a

buildup of finish on the surface [Photo C]. After coating all the edges on a piece, wipe away drips on the underside surface using a clean cloth. Once these edges and the good surface have dried

thoroughly, finish the underside of each piece. Allow all surfaces to dry until there's no solvent odor, or you may have problems later with water-

continued on page 28

THIN PAINT 50 PERCENT



A

USE A PAINT PAD FOR FLAT AREAS



B

A TRIM PAD HANDLES THE EDGES

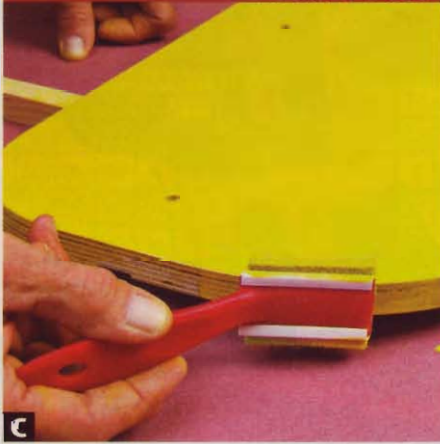

C

BAG PADS DURING BREAKS

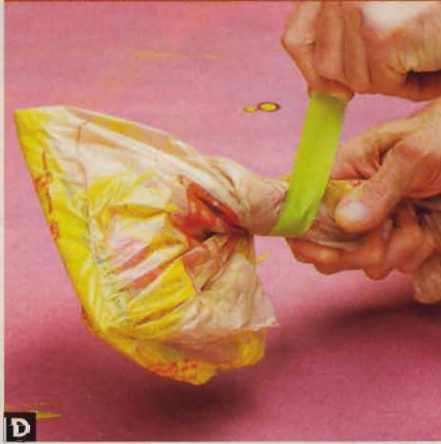

D

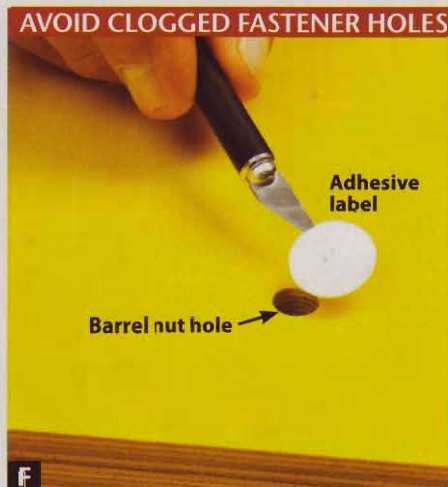
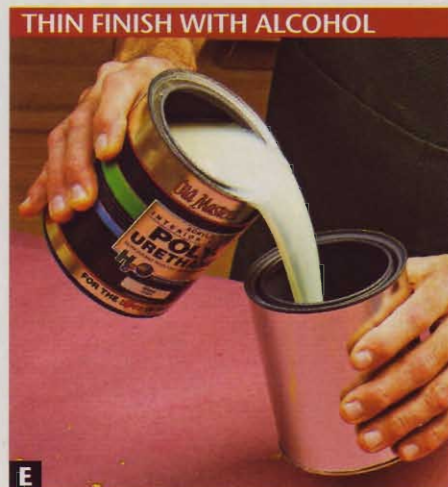

based, clear, protective topcoats not sticking to the color finish. Why use water-based over oil? These finishes typically dry clearer than oil-based ones, preserving the original color.

Oil-based paint dries more slowly than the water-based finish you'll apply next, so save cleanup time between painting sessions by wrapping the applicator and trim pad with plastic sacks sealed with tape around the handles [Photo D]. Then place them in a freezer until about 30 minutes before you're ready to use them again.

Apply a protective finish

Because the toner coat is like a stain, you need to protect it with a clear topcoat. Mix a half-cup of denatured alcohol in one quart of water-based finish to reduce its surface tension and allow bubbles to pop. To avoid overfilling the can, add the alcohol to an empty can and add part of the straight

finish. Pour the contents back and forth until they're well mixed [Photo E]. (Never shake a water-based finish to mix it.) Then fill the bottom of a paint tray with finish.

Unlike the thin toner, this finish could collect inside recesses, such as the holes drilled for barrel nuts used to assemble the bed. Before applying the clear finish, cover all the 10mm holes with round adhesive labels available from any office supply store [Photo F].

Working quickly, apply finish to one surface [Photo G] of each part and then the edges [Photo H]. After the top surfaces dry, finish the undersides.

Troubleshoot finish flaws

Despite thinning with alcohol and careful application, water-based finishes' quick drying time may leave some unpopped bubbles or dust nibs in the dried finish. Instead of sanding these down at risk of damaging the

color coat, slice them off using the sharp edge of a piece of glass with a scrap block attached to one side with double-faced tape [Photo I]. The glass shaves off nibs without marring the surface. Apply one or more coats of clear finish for extra protection.

After the final coat, hand-sand the entire surface with a 320-grit pad. This will dull the surface, but you can bring back a soft sheen by buffing it with a mildly abrasive white Scotch-Brite cleaning pad. To speed up the job, attach an old hook-and-loop sanding disc to the sheet with double-faced tape; then cut it away to create a buffing pad you can attach to a random-orbit sander [Photo J]. For added shine, buff on a coat of paste wax. 🌲

Source

Paint pads. Short-nap, 7" paint pads and touch-up pads available at hardware stores and home centers.
3M Scotch-Brite Pads. Light-Duty Cleansing Pad (white, 6x9") no. 07445, \$20 for 20 pads, Amazon.com.

Rout Perfect Stopped Dadoes and Grooves

Use your plunge router or router table for quick—and accurate—results.

Dadoes and grooves help make simple and strong joinery, but often, you don't want to see any evidence of them on the finished project such as the dovetailed box shown in **Photo A**. For situations like this, use stopped dadoes or grooves that stop before reaching the workpiece's edges or ends, as with the knockdown bed's headboard and footboard on pages 52–56.

SHOW YOUR TAILS, NOT GROOVES

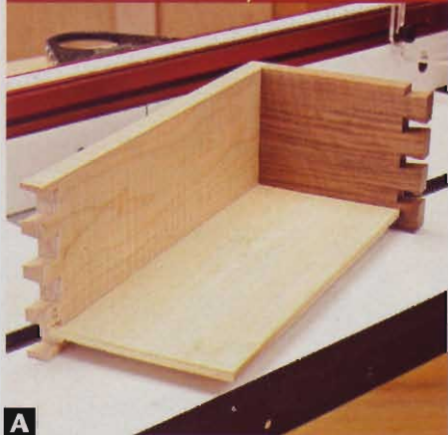

A This dovetail box's bottom is housed in stopped grooves. Had they been cut through the ends, they would have been visible.

You can do this in two ways. A handheld plunge router works best, especially on large workpieces too cumbersome for a router table. Smaller workpieces typically rout best on a router table, where you can take advantage of the fence.

Plunge routers are made for tasks like this

You can use a fixed-base router to create stopped dadoes and grooves—you have to tilt the router into the cut—but doing that is a good recipe for goofing up the groove. With a plunge router, you simply position the bit over the starting point, and then lower it into the workpiece to make the cut. At the end, you simply lift it from the cut.

To make a stopped dado or groove, you need either an edge guide [**Photo B**] or any straightedge (a board or clamp-on guide, for example) to run the router against [**Photo D**]. Rather than eyeballing the starting and stopping points, use stopblocks to prevent the router from going beyond those marks.

First step: Locate and lay out the stopped groove or dado on your workpiece. Next, chuck a straight bit

USE A PLUNGE ROUTER FOR HANDHELD WORK

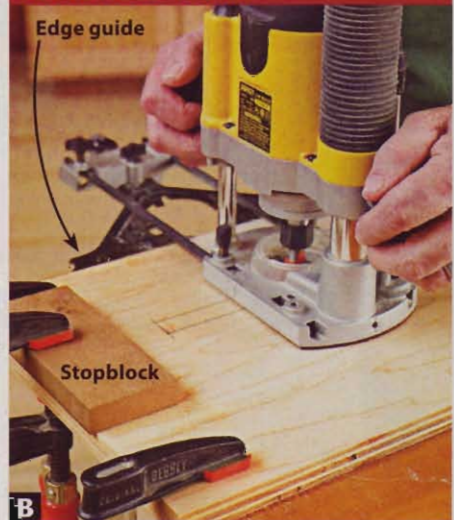

B When using a plunge router with stopblocks, be sure your clamps do not impede the router or edge guide.

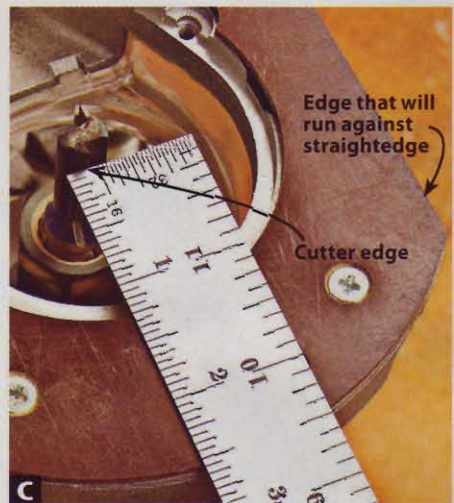

C The distance between the edge of the router base and the bit's cutter ($2\frac{9}{16}$ " in this case) tells you where to position the stopblock.

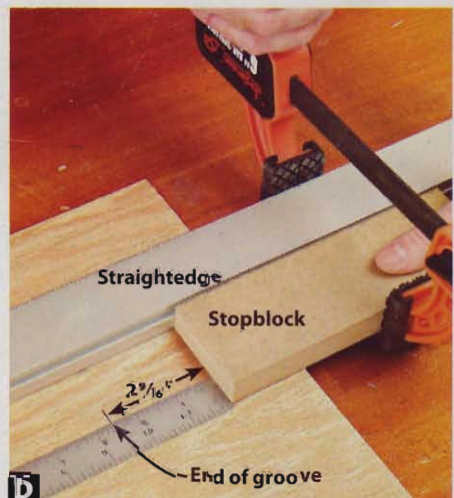

D Clamp the stopblock to the straightedge or bench the distance found in Photo C from the end of the groove or dado.

into your router. (If you don't have a bit that equals the size of the channel, use an undersize bit, and rout it in two passes.) After setting your edge guide or straightedge, measure from the subbase edge to the bit [Photo C]. Use this measurement to position the stopblocks [Photo D]. Don't assume the bit is centered in the base. Take measurements at the leading and trailing edges, and make sure you keep the same point on the subbase against the straightedge throughout the entire cut.

With stopblocks set, you're ready to rout. Here are a few tips:

- Rout channels using 1/8"-deep increments to limit tear-out and prevent your router from straying.
- Clear the workpiece of dust and chips before making subsequent passes—especially the final pass that establishes the finished depth—to avoid the router floating on this debris and cutting an uneven depth.
- Use a downcut spiral bit for cuts and workpieces prone to surface tear-out such as dados in oak plywood.
- Because the router-cut channels will be rounded at each end, use a chisel to square them, if necessary.

A router table delivers quick and easy work

Rout stopped channels on a router table by relying on the fence as your straightedge. After chucking the desired bit into the router and setting its height, position the fence to match the distance between the channel and the workpiece edge. Next, mark the starting and stopping points on the fence [Photo E]. Clamp stopblocks to the fence at those endpoints [Photo F], making sure to position the clamp handles on the back side of the fence.

With the right end of the workpiece against the stopblock and resting on the table—slowly and firmly lower the left end onto the spinning bit [Photo G]. Push the board along the fence until it hits the other stopblock [Photo H]. Turn off the router before lifting your workpiece to prevent accidental gouges or cuts. 🌲

TABLE-ROUT SMALL WORKPIECES FOR BEST RESULTS

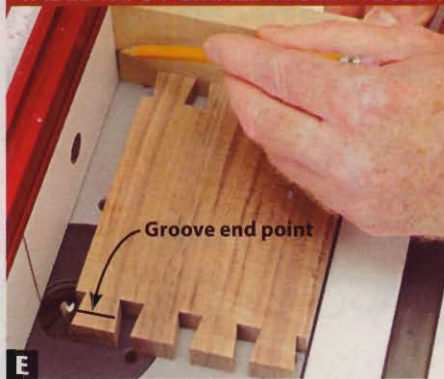

E Set the endpoint at the bit's left cutter edge, and mark a stopping point on the fence at the other end. Repeat for the opposite end.



F Use a spacer to elevate the stopblocks, allowing debris to pass underneath. Remove the spacer before routing.



G Wiggle the workpiece right and left slightly—keeping it trapped against the fence—as you lower it onto the spinning bit.



H Move the workpiece from right to left on a router table. Rout it the opposite way, and the router could yank it from your grip.

WOODCRAFT®

For A Free Catalog Or To Find Your Local Woodcraft Store, Visit www.woodcraft.com Or Call 800-542-9115.

Mix and match with Mixol Universal Tints, now available in 200ml bottles! Mixol Universal Tints are the most concentrated, highest quality tints on the market today.

- Compatible with most water, solvent, lacquer and oil based stains, coatings, shellacs, epoxies, waxes, varnishes, wood fillers, glue, paint, etc...
- Ease of tinting or mixing
- Sophisticated color palette
- Binder-free for a very long shelf/shop life
- LW tints are color-fast, fade-resistant and weather-proof
- Oxide tints are ideal for exterior use or where UV fade may occur
- Mixol tints are not flammable or hazardous
- Clean-up is easy

Dept: 08W105R

www.woodcraft.com/mixol

QUALITY WOODWORKING TOOLS SUPPLIES • ADVICE™

Quick & Easy Jig

Straightedge Setup gauges

When cutting sheet goods with a portable circular saw, streamline the task of offsetting a straightedge from the cutline with these simple guides.

If you routinely use your circular saw and a straightedge to break down sheets of plywood, the dimension from the edge of the saw base to the blade is probably burned into your memory. But if you mark the offset using your measuring tape, you may occasionally make a mistake. It's time to change your ways. Make this pair of setup gauges in minutes, and keep them with your circular saw to save time and eliminate errors. Here's how.

Making the gauges

Measure the width of your circular saw base, add 1", and cut a $\frac{3}{4} \times 2\frac{1}{8}$ " hardwood blank to that length. Now cut a $\frac{3}{4} \times 1\frac{1}{4} \times 8$ " piece of scrapwood for a temporary fence, and screw it to the blank, flush at the bottom, as shown on the drawing below. (For the #8 screws, drill $\frac{5}{32}$ " shank holes and $\frac{7}{64}$ " pilot holes.) Adjust your circular saw to cut $\frac{1}{8}$ " deep, and cut a saw kerf in the blank [Photo A]. Discard the temporary fence. Rip two setup gauges from the blank. [Photo B].

Using the gauges

Mark a short cutline at each edge of the panel you wish to cut. Align the same edge of each setup gauge saw kerf with each marked cutline, and clamp the gauges to the panel. Position the straightedge and clamp it to the panel [Photo C]. Then remove the gauges, and cut the panel. 🌲

Project design: **Dick Babbitt, Friday Harbor, Wash.**

MAKING THE SETUP GAUGES

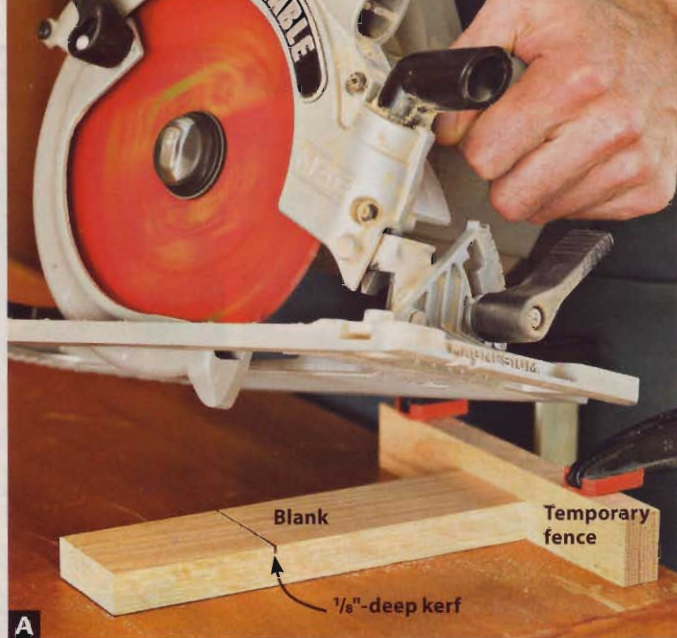
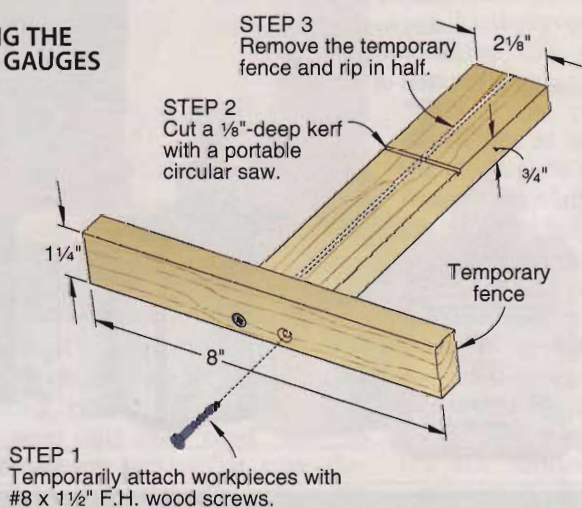

A Clamp the blank and temporary fence to the workbench. Holding the circular saw base against the fence, cut a $\frac{1}{8}$ "-deep kerf.

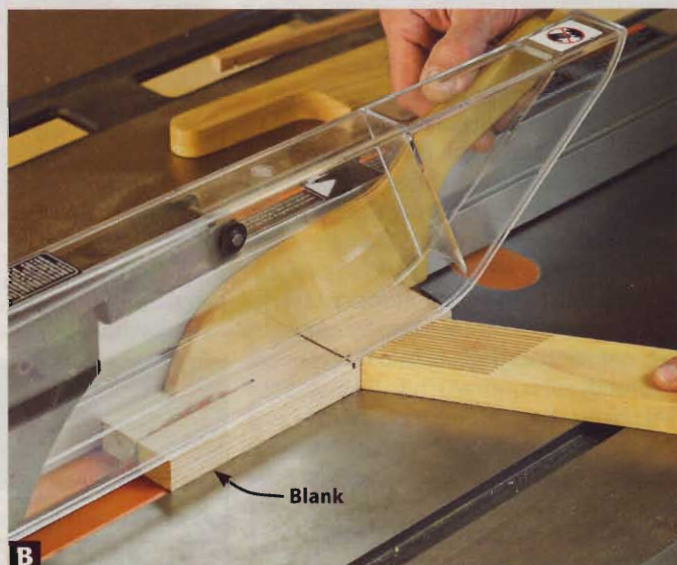

B Remove the temporary fence from the blank and rip the blank in half to make two 1"-wide setup gauges.

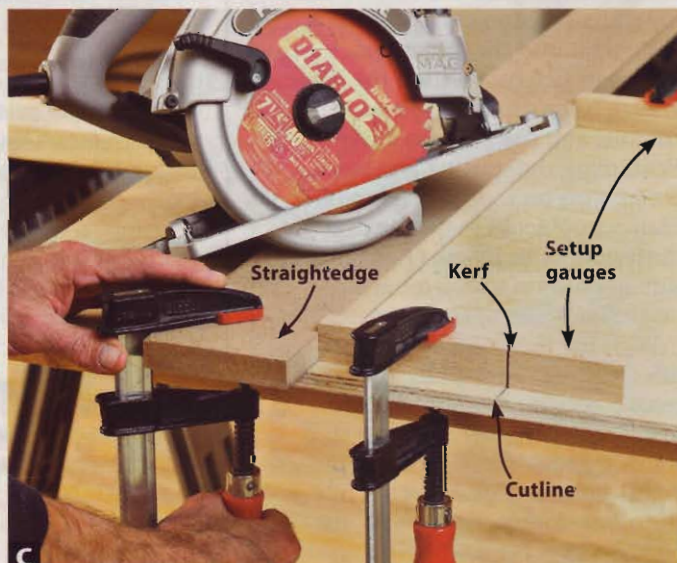

C With the setup gauges clamped to the panel, position the straightedge against the ends of the gauges, and clamp it in place.

Quick, clean rabbets on the tablesaw

House your dado blade in an auxiliary fence, and cut multiple-width rabbets without changing the blade.

Tired of the trial-and-error method of shimming your dado blade to produce a rabbet of the needed width, and then repeating the whole process again for a different width rabbet? Here's a simple, no-shim method for cutting rabbets from $\frac{1}{8}$ " to $\frac{3}{4}$ " wide in one pass.

Step 1 Install a $\frac{3}{4}$ " dado blade in your tablesaw, and position the rip fence $\frac{1}{8}$ " from the blade. Lower the blade beneath the saw table.

Step 2 Attach a $\frac{3}{4}$ "-thick auxiliary fence to the rip fence. (We prefer medium-density fiberboard, but any flat stock will do.) Mark a line on the auxiliary fence $\frac{1}{16}$ " higher than the depth of the rabbet to be cut.

Step 3 With the saw running, slowly raise the dado blade, cutting to the marked line. Lower the blade slightly, and turn off the saw.

Note: Cutting into the auxiliary fence $\frac{1}{16}$ " deeper than needed and then lowering the blade to cut the rabbet keeps the blade from dragging on the fence during the cut.

Step 4 Adjust the fence position and blade height, making test cuts to arrive at the desired rabbet width and depth. Then rabbet your workpiece.

Keep the auxiliary fence handy for future use. When you need to cut a deeper rabbet, simply reposition the tablesaw fence, as in Step 1; attach the auxiliary fence, as in Step 2; and mark the new rabbet depth. Then cut to the new line, as in Step 3. To avoid having a large opening in the auxiliary fence when cutting a shallow rabbet, make several auxiliary fences so each one covers a different range of depths. 🌲



These three $\frac{5}{16}$ "-deep rabbets were cut in three different widths with a $\frac{3}{4}$ " dado blade. Housing the blade in an auxiliary fence makes it easy.

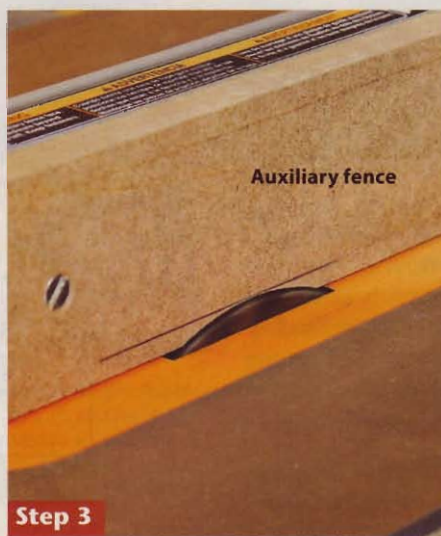
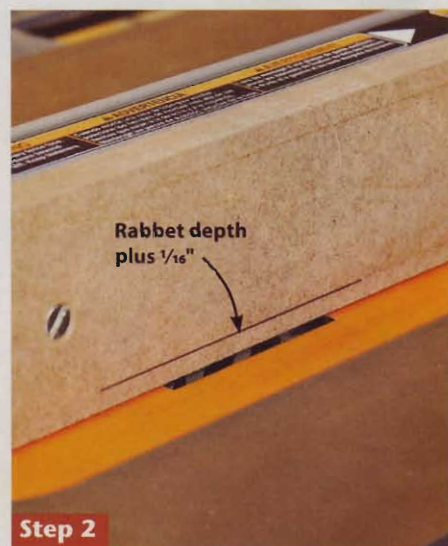
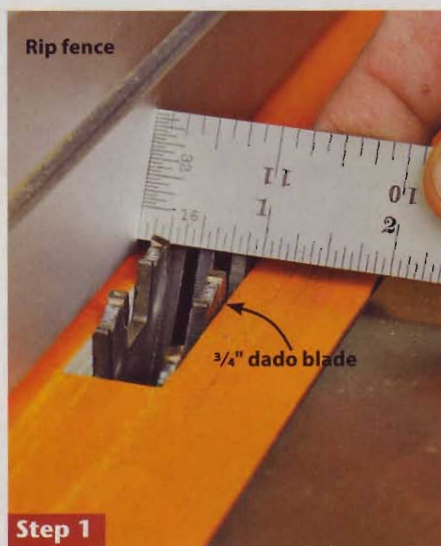

Easy-to-Build Classic Rocker

Talk about comfy! This chair's contoured seat and perfect balance will keep you rockin' for a lifetime. Its straightforward construction requires no tricky or angled joints—just 90° joints held together with screws, dowels, and round tenons in drilled mortises.



PROJECT HIGHLIGHTS

- Overall dimensions: 26 $\frac{5}{8}$ " wide x 37" deep x 47" high.
- Materials needed: $\frac{3}{4}$ " and 8/4 (or laminated) white oak and $\frac{3}{8}$ "-diameter dowel.
- Full-size patterns make shaping the curved parts a snap.
- Weather-resistant white oak and stainless steel screws make this rocker tough enough for outdoor use, but it looks great inside, too!

Skill Builder

- Learn how to form round tenons on parts using a round-over router bit.

Start with the arms

1 Cut the arms (A) to the size listed [Materials List, page 41]. Noting that the left and right arms (as indicated when facing the chair) are mirror images, lay out the shape of each arm and the notch to receive the back leg (I) [Drawing 2]. Mark a centerpoint for drilling a $\frac{1}{4}$ " hole to form a $\frac{1}{8}$ " radius at the cor-

ner of the notches [Drawing 2a]. Then, mark centerpoints for the two countersunk mounting holes at the front of the arms [Drawing 2].

2 Using a $\frac{1}{4}$ " brad-point bit, drill a hole at the marked centerpoint at each notch corner. Then, rout a $\frac{3}{8}$ " round-over across the front edge of each arm on the top face.

3 Using your bandsaw with a fence and stopblock, form the notch in each arm, positioning the stopblock where needed for each cut. (You'll need to flip one arm over to cut the notch. The fence and stopblock let you make the blind cuts.) Remove the fence and stopblock. Then, bandsaw and sand the arms to the layout lines.

4 Rout $\frac{1}{8}$ " round-overs along the top and bottom edges of the arms (A) [Drawings 1 and 2].

5 Mark a centerpoint for a countersunk mounting hole along the outside edge of each arm near the back [Drawing 2]. Now, drill this hole and the two holes at the marked centerpoints

at the front of each arm. (For the #8 screws in this project, drill $\frac{5}{32}$ " shank holes and $\frac{7}{64}$ " pilot holes.) Sand the arms to 220 grit.

Next: rockers 'n' stretchers

1 Cut the rockers (B) to the size listed. Photocopy the rocker full-size front end, center, and back end patterns from the WOOD Patterns® insert. Also, make eight copies of the combined back rail (E) and seat rail (F) end pattern, eight copies of the back slat (G) end pattern, and one copy of the seat slat (J) half-patterns. Put the back/seat rail, back slat, and seat slat patterns aside.

2 To create identically shaped rockers (B), adhere the two blanks together using double-faced tape. Then, spray-adhere the rocker patterns to one face of the taped blanks, aligning the end patterns with the top edge and the center pattern with the bottom edge [Drawing 2].

3 Using a trammel, draw 49 $\frac{1}{2}$ "- and 52"-radius curves to connect the

1a ARM OVERHANG DETAIL (Left arm shown)

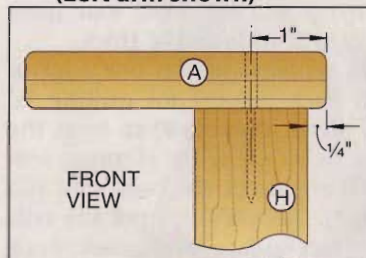

1 EXPLODED VIEW

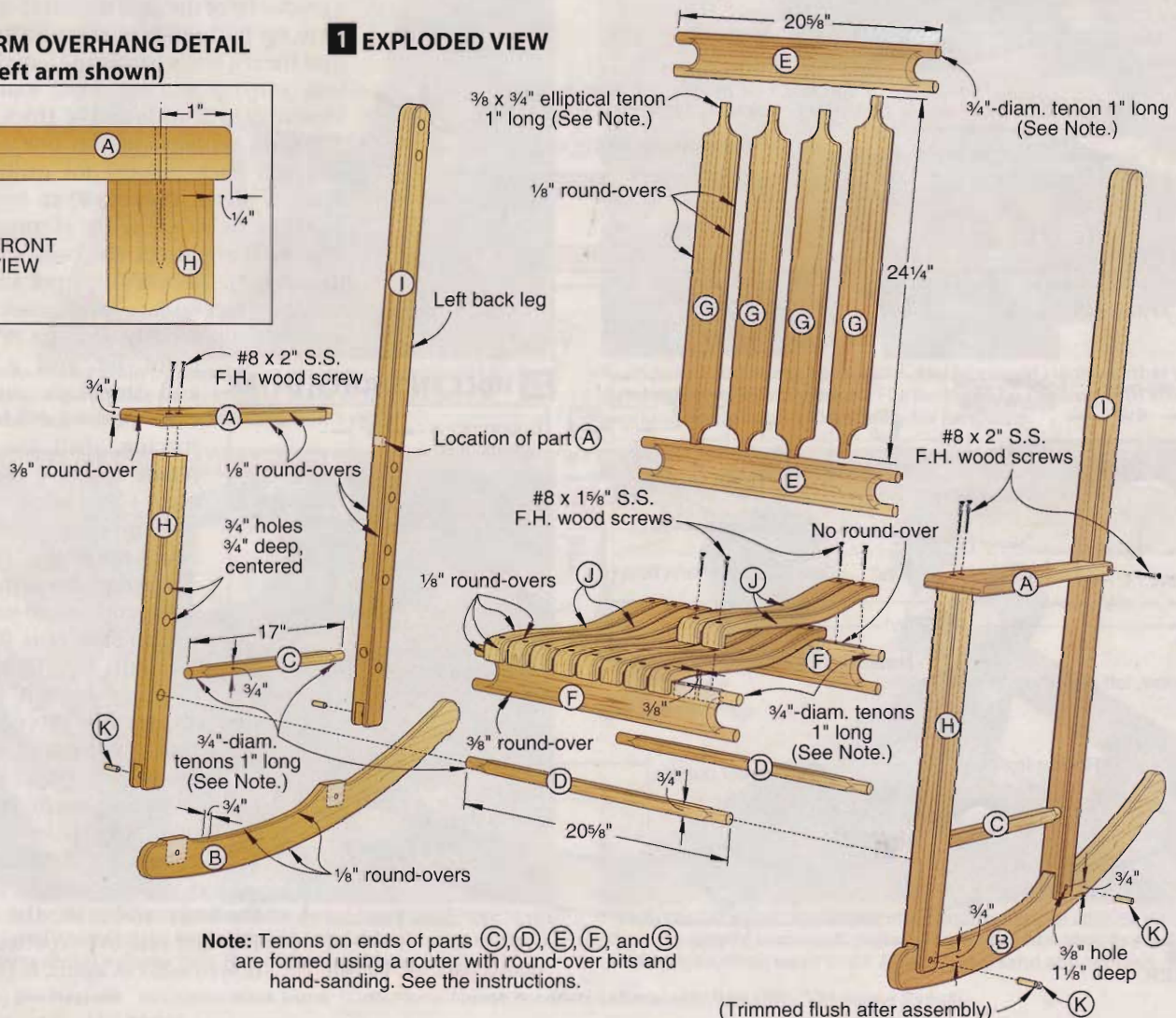



A FORM THE STRETCHER TENONS

Using a $\frac{3}{8}$ " round-over bit, rout all four faces of the stretchers (C, D) at both ends to form $\frac{3}{4}$ "-diameter tenons 1" long.

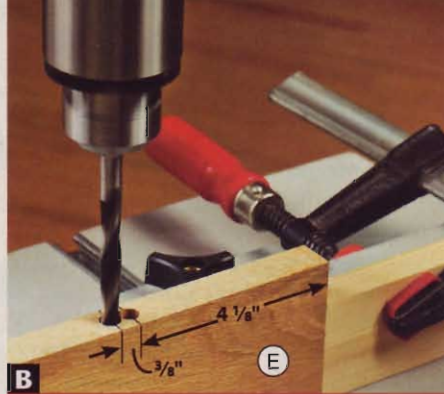

B DRILL THE RAIL MORTISES

Drill $\frac{3}{8}$ " holes $\frac{3}{4}$ " deep at the marked centerpoints on the back rails (E) to form the $\frac{3}{8}$ "- $\frac{3}{4}$ " mortises for the back slats (G).

pattern lines. Now, bandsaw and sand the rockers to shape. Separate the rockers. Remove the tape.

4 Rout $\frac{1}{8}$ " round-overs along the edges of the rockers on both faces [Drawing 1]. Remove the patterns, using a

cloth dampened with paint thinner to soften the adhesive. Sand the rockers.

5 Cut the side stretchers (C) and front/back stretchers (D) to the sizes listed. Save a 4"-long cutoff for use as an alignment pin later. To ensure a precise

fit of the $\frac{3}{4}$ " tenons that you'll form on the stretchers and cutoff to fit into the holes in the front and back legs (H, I) [Drawing 1], make sure the parts are exactly $\frac{3}{4}$ " square.

6 To form the $\frac{3}{4}$ "-diameter tenons 1" long on the stretchers and cutoff, chuck a $\frac{3}{8}$ " round-over bit in your table-mounted router. Position a stopblock on the *outfeed* side of the bit, 1" from its center. Then, rout both ends of the stretchers and one end of the cutoff on all four faces [Photo A]. This will leave a slightly nonuniform profile around the shoulders of the tenons. To create an identical profile for the best appearance, reposition the stopblock on the *infeed* side of the bit, 1" from the center. Now, repeat the routing process, feeding from the outfeed side. For help with this technique, see page 42. Do not change the router setup.

2 PARTS VIEW

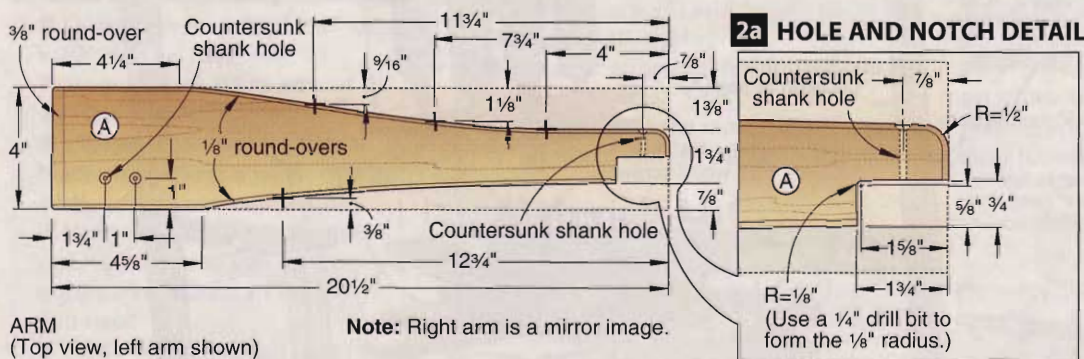
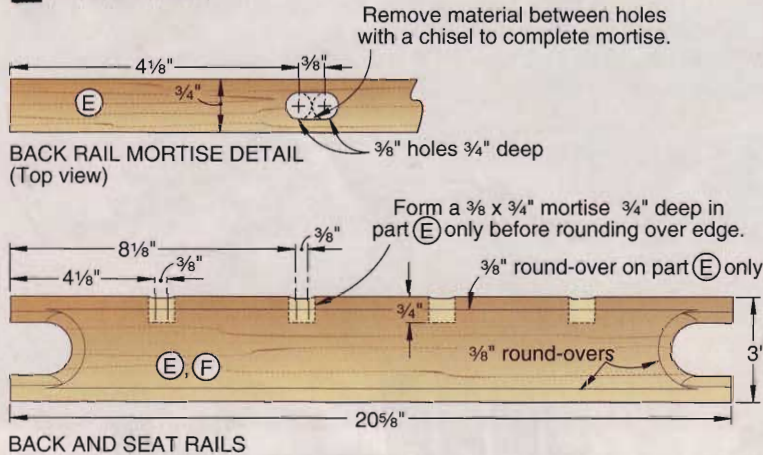

ARM (Top view, left arm shown)

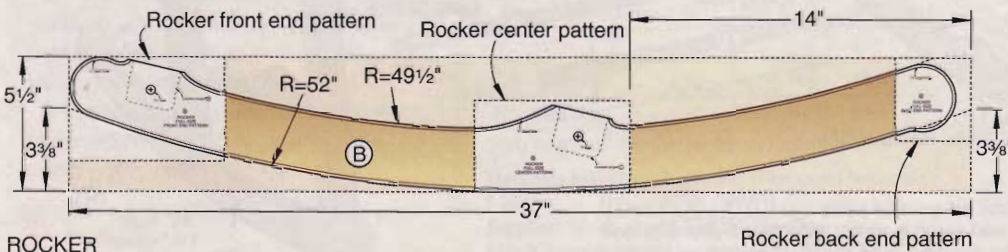

Time for the rails

1 Cut the back rails (E) and seat rails (F) to the size listed. Again, to ensure a precise fit of the dual tenons that you'll form on both ends of these parts to fit into the leg holes [Drawing 1], make sure that you rip and plane all four parts *identically* to 3" wide and $\frac{3}{4}$ " thick.

2 Mark centerpoints on one edge of each back rail (E) for drilling $\frac{3}{8}$ " holes $\frac{3}{4}$ " deep [Drawing 2] to form the mortises for receiving the elliptical tenons on the ends of the back slats (G) [Drawing 1]. To save time, put the rails together face-to-face and mark both edges simultaneously. Using a $\frac{3}{8}$ " brad-

point bit and a fence and stopblock on your drill press for identical spacing, drill the holes [Photo B]. Now, use a $\frac{3}{8}$ " chisel to remove the remaining material between the holes.

3 Spray-adhere the photocopied end patterns to the back rails (E) and seat rails (F). To cut the opening at each end of

the rails, leaving precise $\frac{3}{4}$ " x $\frac{3}{4}$ " stubs that you'll round over to form the tenons, position your bandsaw fence *exactly* $\frac{3}{4}$ " from the *inside* of the blade, and set a stopblock for a 1"-long cut.

Next, place a rail tight against the fence and make the 1" cut. Flip the rail over (pattern side down) and cut again. Repeat the

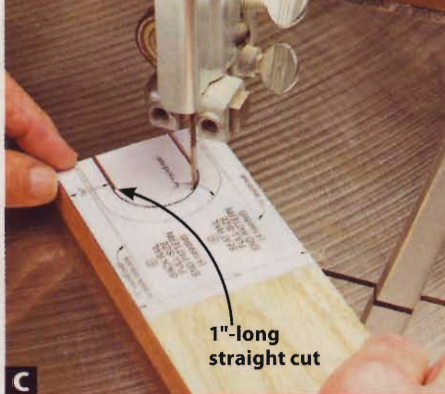

C BANDSAW THE RAILS

After making the 1"-long straight cuts into the rails (E, F), remove the fence and bandsaw the curved openings to shape.

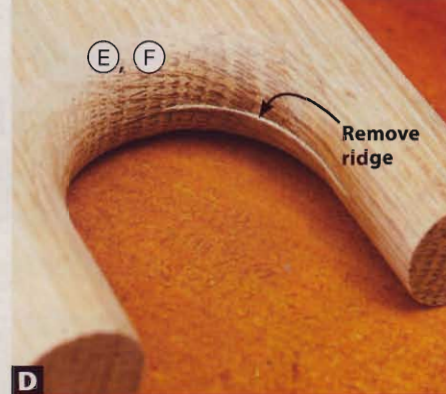

D SAND THE RAIL OPENINGS

Routing the $\frac{3}{8}$ " round-overs along the openings in the rails (E, F) leaves thin ridges of extra material. Sand away the ridges.

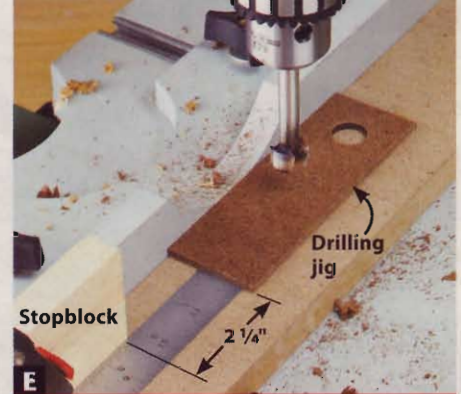

E MAKE A SIMPLE JIG

With the first $\frac{3}{4}$ " hole bored through the drilling jig, position the jig precisely $2\frac{1}{4}$ " from the stopblock, and bore another hole.

process at the other end of the rail and at both ends of the remaining rails. Now, bandsaw and drum-sand to the pattern line to complete the openings [Photo C]. (We used a 1"-diameter sanding drum.) Be careful not to over-sand and reduce the $\frac{3}{4} \times \frac{3}{4}$ " stubs.

4 Using your router-table setup, rout $\frac{3}{8}$ " round-overs along the top and bottom edges of the back rails (E) and the bottom edges of the seat rails (F) [Drawings 1 and 2]. Now, remove the fence and rout along the opening at each end of the rails on both faces to complete rounding of the $\frac{3}{4}$ "-diameter tenons. Note that when you flip the rails to rout the opposite sides of the openings, the bit bearing rides slightly high due to the initial round-over, which leaves a thin ridge of excess material [Photo D]. Remove the ridges by hand-sanding with 150-grit sandpaper. Remove the patterns. Sand the rails.

On to the back slats

1 Cut the back slats (G) to the size listed. Spray-adhere the end patterns to the slats. Bandsaw and sand to the pattern lines.

2 Refit your table-mounted router with a $\frac{3}{8}$ " round-over bit. Then, with the fence removed, round over the edges of the slats [Drawing 1], forming an elliptical tenon at each end. Check the fit of the tenons into the mortises in the back rails (E). Sand the tenons as needed for easy insertion but not loose joints. Remove the patterns. Sand the slats.

Prepare the legs

1 From $8/4$ or laminated $\frac{3}{4}$ " stock, cut the front legs (H) and back legs (I) to the sizes listed. Then, lay out the centered $\frac{3}{4}$ " dado $1\frac{3}{4}$ " deep at the bottom of each leg [Drawing 3] to receive the rockers (B). Cut the dadoes, as explained in the **Shop Tip**, below.

2 Noting that the right front and back legs (H, I) are mirror images of the left legs, mark centerpoints on the appropriate edges and faces of the legs for the centered $\frac{3}{4}$ " holes $\frac{3}{4}$ " deep [Drawing 3].

3 To accurately bore the holes spaced $2\frac{1}{4}$ " apart that will receive the tenons on the back and seat rails (E, F), cut a 2×6 " piece of $\frac{1}{4}$ " hardboard for a drilling jig. Mark a centerpoint $1\frac{1}{2}$ " from an end of the jig, centered on the 2" width. Using a $\frac{3}{4}$ " Forstner bit in your drill press and a fence and stopblock, bore a hole at the centerpoint. Now, bore another hole centered $2\frac{1}{4}$ " from this hole [Photo E]. Check that the tenons on a rail fit into the jig holes. If needed, make another jig, adjusting the hole spacing to mate with the tenons. Remove the stopblock. Do not move the fence.

4 Place the left front leg (H) on your drill-press table with the *inside* face

SHOP TIP

How to safely cut a dado into the end of a long part

Using your tablesaw to cut a dado into the end of lengthy workpieces, such as the front and back legs (H, I), can be awkward and dangerous. Here's an easy and safe way to do it using your bandsaw.

To form the centered $\frac{3}{4}$ " dadoes $1\frac{3}{4}$ " deep in the bottom ends of the legs, for example, position your fence $\frac{3}{8}$ " from the inside of the blade, and set a stopblock for the $1\frac{3}{4}$ "-long cut. With a face of a leg tight against the fence, make a cut to form one face of the dado, rotate the leg 180° , and cut again, as shown at *right*. Repeat for each leg. Then, to remove the waste, move the fence approximately $\frac{1}{8}$ " farther away from the blade. Make a cut, rotate the leg, and

cut again. Repeat for each leg. Continue the shift-and-cut process to kerf the remaining waste. Now, using a sharp $\frac{5}{8}$ "

chisel, chip out the waste, as shown *below*, alternately working from the edges to the center.

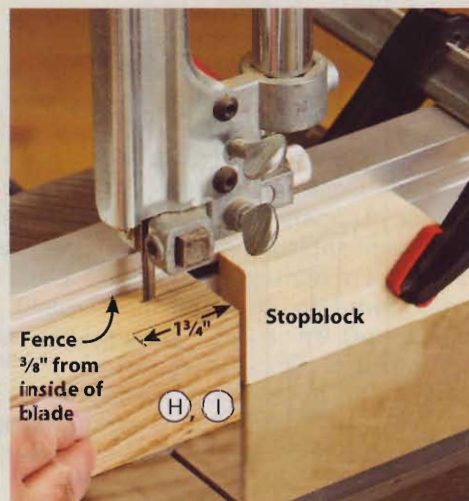

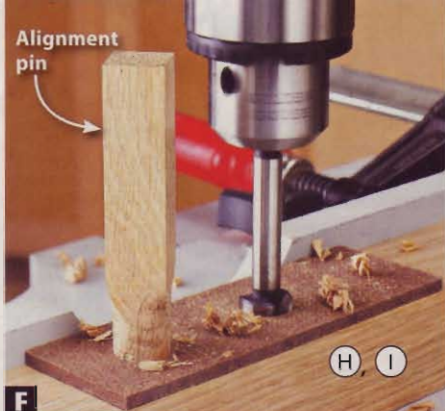

F BORE THE LEG HOLES

With the drilling jig pinned in position on the legs (H, I), use the open jig hole as a guide to bore the $\frac{3}{4}$ " holes $\frac{3}{4}$ " deep into the legs.

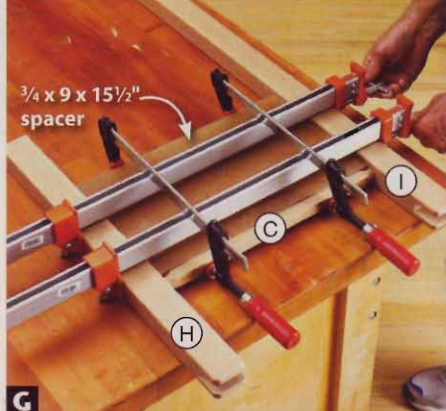

G GLUE AND CLAMP THE SIDES

Glue and clamp the right front and back legs (H, I) and side stretcher (C) together, using the spacer to correctly position the legs.

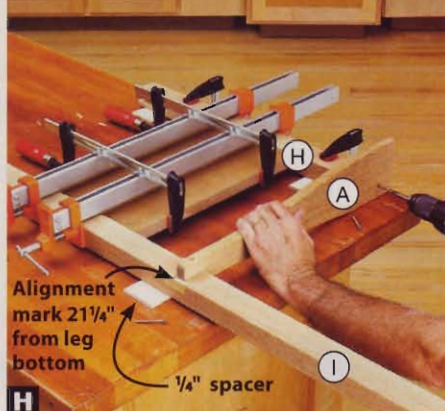

H ATTACH THE ARM

Mount the appropriate arm (A) to a side assembly, making sure the bottom face of the arm is aligned with the mark on the back leg.

up and tightly against the fence. Bore a $\frac{3}{4}$ "-deep hole at the marked centerpoint $11\frac{7}{8}$ " from the bottom of the leg.

Next, position the drilling jig on the leg with one hole aligned with the hole in the leg and the adjacent marked centerpoint on the leg visible in the other jig hole. Insert the round end of the alignment pin that you made earlier into the aligned hole [Photo F]. Reposition the leg to align the bit with the open jig hole. Now bore the hole into the leg. Repeat the process to bore the pairs of holes in the right front leg and both back legs (I) at the marked locations, making sure that you always bore the bottom hole of each pair of holes first to ensure correct rail alignment.

5 Remove the drilling jig. Then, bore the hole into each leg face at the marked centerpoints to receive the tenons on the front/back stretchers (D). Reposition the fence to center the bit on the $1\frac{1}{2}$ " thickness of the legs. Now, bore the hole at the marked centerpoint on the edge of each leg to accept the tenons on the side stretchers (C). Use a stopblock to ensure alignment of the holes.

6 Mark the $\frac{3}{8}$ " radii at the bottom of each front and back leg (H, I) and the 1" radius at the top of each back leg [Drawing 3]. Bandsaw and sand the radii to shape.

7 Rout a $\frac{1}{8}$ " round-over along the edges of the legs [Drawing 3]. Sand the legs smooth.

Shape the seat slats

1 Cut the seat slats (J) to the size listed. Spray-adhere the seat slat half-patterns to a face of a slat blank, joining them where shown. Then, using a $\frac{5}{32}$ " brad-point bit in your drill press and your fence with a stopblock, drill a centered shank hole at each end of the slats, where shown on the pattern. (Using your fence and a stopblock lets you drill

identical holes in the slats without the pattern.) Countersink the holes.

2 Bandsaw and sand the seat slat (J) with the pattern to shape. Using this part as a template, mark the shape on the remaining slats. Then, bandsaw and sand them.

3 Rout a $\frac{1}{8}$ " round-over along all of the edges of the slats. Sand the slats.

Assemble the sides

1 From scrap $\frac{3}{4}$ " plywood or MDF, cut a $9 \times 15\frac{1}{2}$ " piece for a spacer. Apply glue into and spread it around the holes in the right front and back legs (H, I) for the side stretcher (C). Then, assemble the parts with the spacer [Photo G]. Repeat to assemble the left side.

2 To mount the arms (A), make an alignment mark on the outside face of each back leg (I) at the back edge $21\frac{1}{4}$ " from the bottom [Drawing 3]. Position and clamp a side assembly (with the $9 \times 15\frac{1}{2}$ " spacer again clamped in place) to your workbench, outside face up, on

$\frac{1}{4}$ "-thick spacers. This positions the front of the arm so that it overhangs the inside face of the front leg (H) $\frac{1}{4}$ " [Drawing 1a].

Next, apply glue to the top of the front leg and to the notch in the appropriate

3 LEGS

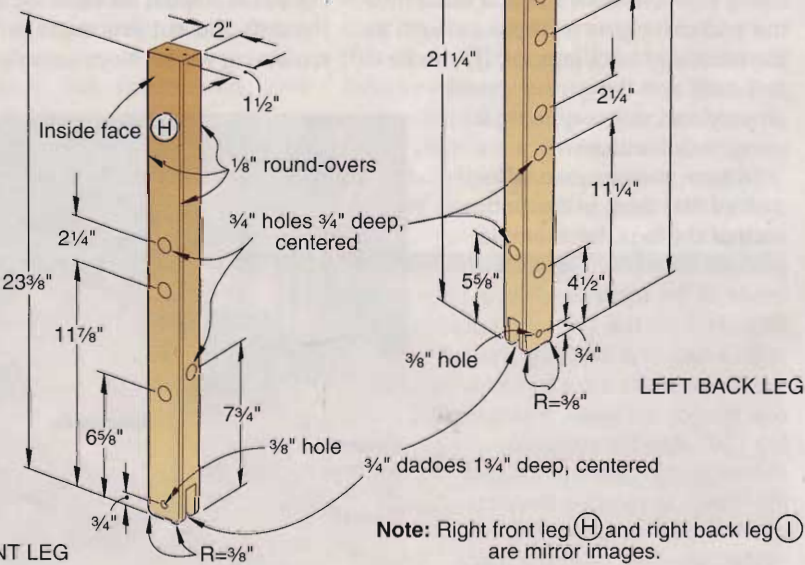

Note: Right front leg (H) and right back leg (I) are mirror images.

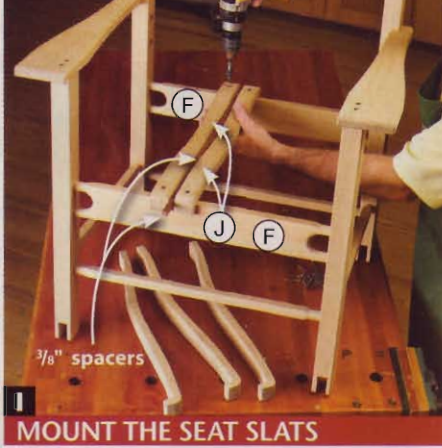

I MOUNT THE SEAT SLATS

With the center seat slat (J) in position, use $\frac{3}{8}$ "-thick spacers to position the remaining slats for mounting to the seat rails (F).



J ADD THE ROCKER

Drill the $\frac{3}{8}$ " holes $1\frac{1}{8}$ " deep into the front and back legs (H, I) and rocker (B). Wrap the bit with masking tape for a visual depth stop.

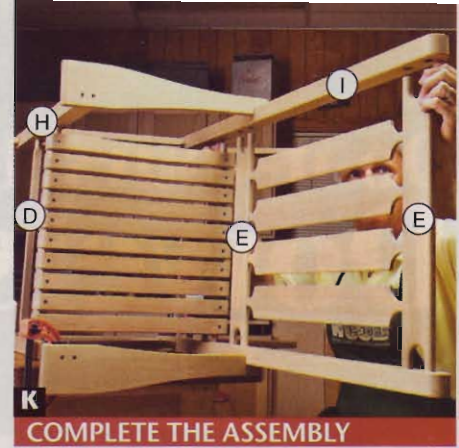

K COMPLETE THE ASSEMBLY

With the front/back stretchers (D), seat rails (F), and back rails (E) assembled to a side assembly, align and install the opposite side.

arm. Place the arm into position, aligning the bottom face of the arm with the mark on the back leg. Using the pre-drilled mounting holes in the arm as guides, drill pilot holes into the legs. Now drive the screws [Photo H]. Repeat to mount the other arm.

Complete the assembly

1 To assemble the seat slats (J) to the seat rails (F), mark the center of the rails on the top edges. Then, dry-assemble the side assemblies (A/C/H/I), front/back stretchers (D), and seat rails (F). *If the tenon joints are tight, do not fully engage them at this time as you may not be able to separate them later.*

2 Position a seat slat (J) on the seat rails (F), offset $\frac{3}{16}$ " from the marked centerlines, with the front end tightly against the front rail. (It does not matter which direction you shift the slat.) Using the mounting holes in the slat as guides, drill pilot holes into the rails. Drive the screws. Remove the alignment lines. Now, using a pair of $\frac{3}{8}$ "-thick spacers, mount the remaining slats [Photo I]. Separate the side assemblies from the front/back stretchers (D) and seat rail/slat assembly (F/J).

3 Reclamp a side assembly with the *outside* face up to your workbench on the $\frac{1}{4}$ " spacers. Mark centerpoints on the legs for the $\frac{3}{8}$ " holes $1\frac{1}{8}$ " deep to receive the dowels (K) for pinning the rocker (B) in place, where dimensioned [Drawings 1 and 3]. Next, insert a rocker in the correct orientation into the leg dados, with the front leg centered on the flat top edge of the rocker. Drill the holes [Photo J]. Repeat for the other rocker and side assembly.

4 From a $\frac{3}{8}$ "-diameter birch dowel, cut four $1\frac{1}{2}$ "-long pieces for the dowels (K). (If you want to use white-oak dowels to match the other parts, you can make them as explained on page 42.) Apply glue into and spread it around the aligned holes in the front and back legs (H, I) and rockers (B). Drive the dowels into the bottom of the holes. Let the glue dry overnight. Then, trim the dowels using a flush-trim saw, and sand smooth. To prevent marring the legs with the saw, place an index card with a hole in it over the dowels.

5 To complete the rocker, clamp a side assembly to your workbench with the *inside* face up and the arm (A) overhanging the top. Dry-assemble the back

rails (E) and back slats (G). Then, apply and spread glue into the $\frac{3}{4}$ " holes in the front and back legs (H, I). Working quickly, insert the tenons on the front/back stretchers (D), seat rails (F), and back rails (E) into the holes. Now, apply glue into the holes in the other side assembly, and install it [Photo K]. Tap the joints together using a rubber mallet. Now, clamp the side assemblies to fully seat all of the tenons into the holes.

Finish up

1 Finish-sand to 220 grit any areas that need it, and remove the dust.

2 Apply two coats of a clear finish. For indoor use, apply a water-based polyurethane. For outdoor use, apply two coats of a spar varnish or marine finish, such as Sikkens. Now take a seat, and set 'er in motion! 🪑

Written by **Owen Duvall** with **Chuck Hedlund**

Project design: **Jeff Mertz**

Illustrations: **Roxanne LeMoine; Lorna Johnson**

Cutting Diagram



$\frac{3}{4}$ x $7\frac{1}{4}$ x 96" White oak (5.3 bd. ft.)
*Plane or resaw to the thickness listed in the Materials List.



$\frac{3}{4}$ x $7\frac{1}{4}$ x 96" White oak (5.3 bd. ft.)

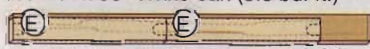

$\frac{3}{4}$ x $3\frac{1}{2}$ x 48" White oak (1.3 bd. ft.)

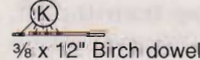

$\frac{3}{8}$ x 12" Birch dowel

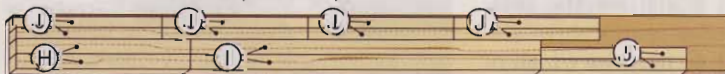

$1\frac{1}{2}$ x $7\frac{1}{4}$ x 96" White oak (10.7 bd. ft.)

Materials List

Part	FINISHED SIZE			Matl.	Qty.
	T	W	L		
A arms	$\frac{3}{4}$ "	4"	20 $\frac{1}{2}$ "	O	2
B rockers	$\frac{3}{4}$ "	5 $\frac{1}{2}$ "	37"	O	2
C side stretchers	$\frac{3}{4}$ "	$\frac{3}{4}$ "	17"	O	2
D front/back stretchers	$\frac{3}{4}$ "	$\frac{3}{4}$ "	20 $\frac{5}{8}$ "	O	2
E back rails	$\frac{3}{4}$ "	3"	20 $\frac{5}{8}$ "	O	2
F seat rails	$\frac{3}{4}$ "	3"	20 $\frac{5}{8}$ "	O	2
G back slats	$\frac{3}{8}$ "	3"	24 $\frac{1}{4}$ "	O	4
H front legs	$1\frac{1}{2}$ "	2"	23 $\frac{3}{8}$ "	O	2
I back legs	$1\frac{1}{2}$ "	2"	47"	O	2
J seat slats	$1\frac{1}{2}$ "	$1\frac{1}{2}$ "	19 $\frac{9}{16}$ "	O	10
K* dowels	$\frac{3}{8}$ " diam.		1 $\frac{1}{8}$ "	BD	4

*Part initially cut oversize. See the instructions.

Materials key: O—white oak, BD—birch dowel.

Supplies: Double-faced tape, spray adhesive, #8x $1\frac{1}{8}$ " and #8x2" stainless steel flathead wood screws.

Bits: $\frac{1}{4}$ ", $\frac{3}{8}$ ", and $\frac{5}{32}$ " brad-point bits; $\frac{1}{8}$ " and $\frac{3}{8}$ " round-over router bits; $\frac{3}{4}$ " Forstner bit.

Do-it-yourself Dowels & Round Tenons



When you need to make a square part fit a round hole, summon your router to the rescue.

Once you know how to rout round tenons, any drill press with a Forstner bit becomes a mortising machine. Plus, you'll always have dowels of any length or wood species you want—even a zebrawood dowel like the one at right.

To make either dowels or round tenons, start with dry, straight-grained stock. Wild grain or incompletely dried stock can twist out of shape after cutting relieves stresses in the wood, as shown below.

Rip stock that's about 3" longer than the dowel or tenon you need. Joint and plane blanks square for consistently rounded edges from your router.

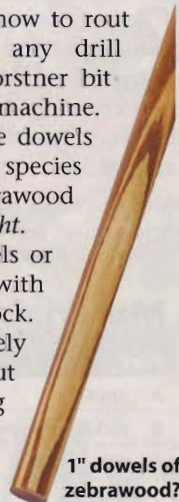

1" dowels of zebrawood? Why not!

WET WOOD = WARPED DOWELS



The high moisture content and irregular grain of 2x4 pine makes it poor dowel stock. These examples warped after routing.

Set up your router table

On a table-mounted router, install a round-over bit with a radius equal to half the dowel or tenon blank width. For example, use a 1/2"-radius bit to rout a 1" dowel or tenon from 1"-square stock. Then move the router-table fence flush with the bit bearing, and check it with a straightedge [Photo A].

Next, raise the bit so it makes a full round-over cut plus a slight shoulder on your test scrap. Lower the bit and make short test cuts until the shoulder disappears [Photo B]. Now you're set up to cut dowels or tenons.



Getting around to dowels

Mark lines 1" from each end of the dowel blank on all four faces. With the marks on the left end aligned with but not touching the bit, start the router and push the blank firmly against the fence and into the bit [Photo C]. Immediately feed the blank past the bit using push pads or a pushstick. Stop when you reach the mark on the right end of the workpiece, and slide it away from the bit. Rotate the workpiece 90° and make a second pass; then repeat for the final two passes.

Dowels longer than half the width of your router table require a different

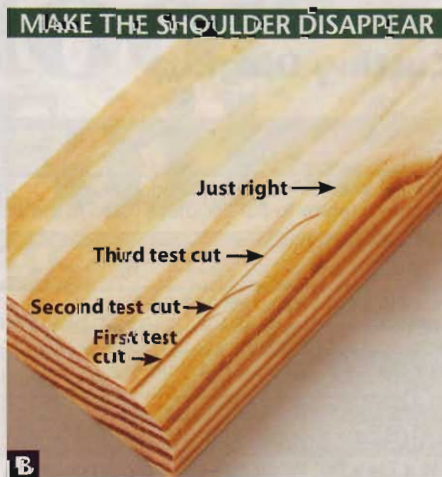

approach. To prevent the square ends from dropping off the edge of the router table, double-face tape the dowel

stock to a carrier board of equal length and thickness [Photo D]. Then use the carrier board to keep the dowel from

turning as it's routed. After each pass, rotate the workpiece and retape it to the carrier for the next pass.

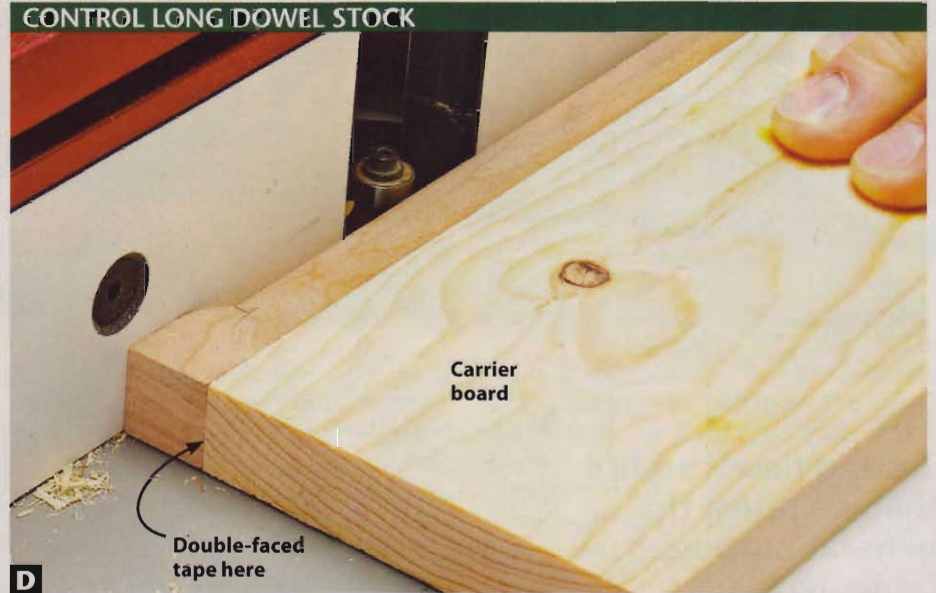
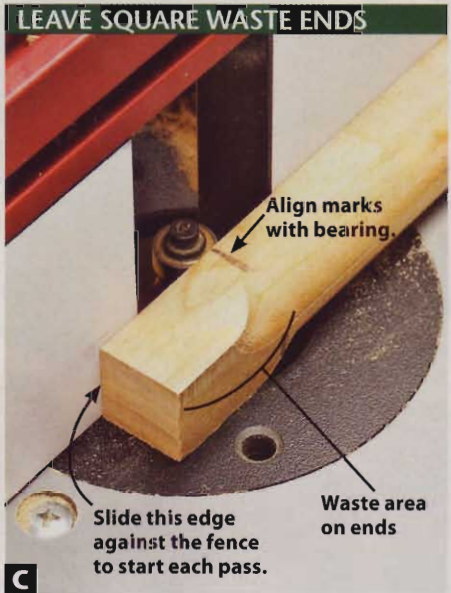

Attach Stops to Rout Round Tenons

Start by clamping a stopblock onto the router table fence at a distance from the bit center equal to the round tenon length. Using a push pad, rout the first round-over up to the stop. Rotate the workpiece 90° [Photo E] and make three passes to complete the tenon. Repeat for the remaining workpieces and a couple of test scraps. You can test the diameter of a tenon by fitting it into a round mortise drilled into a piece of scrap [Photo F], but you're not quite finished.

Look closely at the curving tenon shoulders left by the bit, and you'll notice that one side curves outward and the other inward [Photo G]. To make the curves symmetrical, you'll need to climb-cut them. In climb-cutting, you feed the stock in the direction where the bit pulls the material into itself instead of pushing against it.

Reposition the stopblock on the right the same distance away from the bit. Then use a push pad to slowly climb-cut all four shoulders of your test piece [Photo H]. When they're symmetrical, climb cut both ends of each workpiece.

Note: If you climb-cut into the square portion of the stock, and hold the workpiece by hand or fail to use a stopblock, the router can instantly grab and pull the workpiece—and your fingers—into the bit. Always use a stopblock and push pads.

Then carefully smooth the shoulders with a dowel wrapped in sandpaper to preserve the symmetrical profiles.

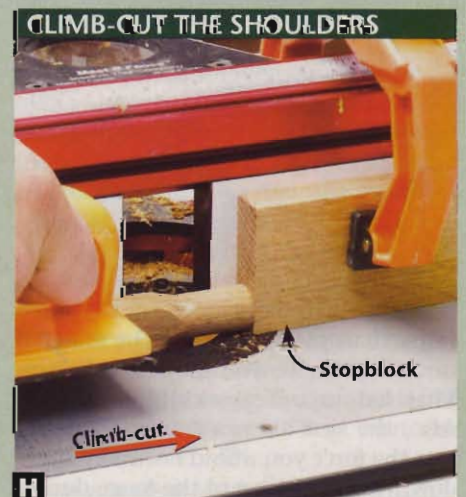
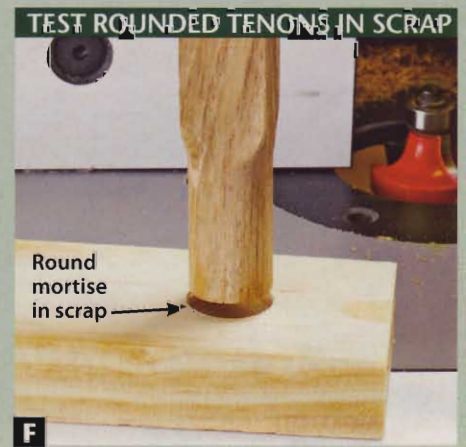

Saw blades II

The Retest



Testing flaws require that we retest the general-purpose tablesaw blades originally reviewed in the December/January issue.

In our test of 10" blades on pages 42–45 of the December/January issue, as with all of our product reviews, we did our best to create a level playing field for the blades. In that spirit we designed and built a rip-cut sled that pulled all test stock through each blade with 12½ pounds of force. We've since discovered that device and procedure to be flawed. For many materials the sled pulled the board through the blade too fast—much faster than you would feed the material under normal workshop conditions. That led to unrealistically poor cuts. Also, the sled did not accurately duplicate the force you would normally apply downward and toward the fence during

an actual cut, introducing unnecessary scoring to the workpiece. Bottom line: The cuts we got from the sled are not an accurate reflection of what you would expect to get in your shop.

To remedy this situation we took the unprecedented step of retesting all of the blades. We're just not satisfied knowing that you might buy the wrong blade based on the previous article—and our tool tests are all about you getting the most bang for your woodworking buck. During this test, we hand-fed the stock, using the feedback from the saw and workpiece to tell us how fast to feed the material, just as you would do in your home shop. As a result, the new perfor-

mance grades better reflect the cut quality you can expect from each blade.

Finally, be assured that we stand behind all previous tool tests and feel 100 percent confident that you can use them to make informed tool purchases. We place utmost importance on providing you with accurate and unbiased tool tests. And it's for that very reason that we redid this test. At *WOOD*® magazine we realize that most of you keep your magazines as a reference source for years to come, so it is our policy to immediately correct any mistakes, be it a dimensional error in a project or a testing flaw, enabling you to correct your back issue. It doesn't happen very often, but when

it does we put your success above our egos. You, our loyal customers, deserve nothing less.

Some of what we learned before still applies

On the following pages you'll find a new comparison chart for the 28 tested blades. We added cuts in 4/4 and 8/4 red oak because so many of you use that popular species. Gone are grades for ease of feed (more on that later) and grades for scoring on the edges of plywood and melamine-coated particleboard. On the *last page* of this article you'll find clear criteria for what constitutes an A, B, C, or D grade for each cut, along with photos showing what the various grades represent in three of the test cuts.

We didn't repeat all of the specifications (such as tooth count and hook angles) from the original chart. Those things have not changed.

That said, it still pays to heed a number of lessons learned from the first test, with a few new findings added:

■ **Previous lesson:** Even the best blade will not perform well in a saw that's not properly adjusted. So take the time to remove any runout from your saw's arbor. Align the fence, miter slots, and blade precisely parallel with each other. **New finding:** Err on toeing out the back end of the fence .001" or .002" away from the blade—that will reduce the likelihood of the workpiece binding between the blade and fence.

■ **Previous lesson:** Many of the tested saw blades yield clean cuts on the top face of melamine-coated particleboard. **New findings:** Only the Freud P410 produced chip-free cuts on the top and bottom faces of melamine (using a standard tablesaw throat plate and a slow feed rate). To improve the bottom-cut performance of the other blades we retried them using a zero-clearance insert. (See photo *right top*.) About half of the blades, such as the Forrest WW10407125, improved noticeably, as shown *right middle*. We got even better results in birch plywood crosscuts. There, a zero-clearance insert eliminated bottom tear-out with nearly every blade, potentially raising their crosscut tear-out performance in plywood by two full grades. (See photo *right bottom*.) Remember that the grades in the chart were determined using a standard tablesaw throat plate, not a zero-clearance insert. To learn how to make an insert go to woodmagazine.com/zeroclearance.

■ **Previous lesson:** Thick carbide saw teeth give you more resharpenings. **New finding:** Some of the blades have teeth with complicated grinds, so have your blades sharpened by a service with up-to-date computer-controlled grinding equipment that will duplicate the manufacturer's original grind. To be on the safe side, check the manufacturer's Web site for recommended sharpening services. For example, you can return Forrest and Ridge Carbide blades to the manufacturer for resharpening. By the time you read this, Freud's site should have a list of recommended sharpening services.

■ **New finding:** Ease of feed depends primarily on whether a blade has thin-kerf teeth (.118" or narrower) or full-kerf teeth (.125" thick or thicker), so we separated the chart into thin- and full-kerf categories, then listed them by price. A 3-hp tablesaw on a 220-volt circuit has enough muscle to power a full-kerf blade through nearly any cut. But if you're using a 110-volt saw you'll find that a thin-kerf blade plows more easily through tough cuts. Of course, either type will struggle if dull.

Recommendations

For the purpose of choosing the Top Tool and Top Value winners, we had to look at how the blades performed in all of the tested materials. But as you look at the grades in the chart, keep in mind the type of saw you use and what type of work you do. For example, if you work entirely in 3/4" hardwoods, focus your attention on the grades for cuts in 4/4 maple and oak. Buy the best-priced blade that does well in the materials you'll cut with it. In other words, don't pay extra for a blade because it excels in a material you'll never cut.

Below you'll find recommendations in five categories broken down by full- or thin-kerf and price range.

Full-kerf blades priced \$97 or more:

You'll be happy with the cuts you get with any of these premium blades. The Freud P410 and Infinity 010-044 scored slightly better than the others, earning Top Tool honors. Both of those blades owe some of their success to their highly beveled, 30° teeth that cut crisp edges but will dull faster than the 20° beveled teeth on the Forrest WW10407125 and

AN EASY WAY TO IMPROVE ANY BLADE'S PERFORMANCE

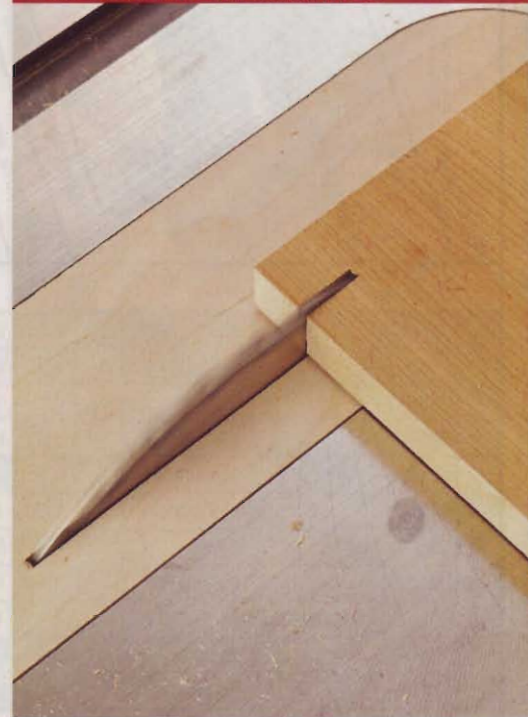

This shop-made zero-clearance insert fully supports delicate veneer fibers as the blade's teeth exit the cut.

ZERO-CLEARANCE INSERTS UPGRADE SHEET-GOOD CUTS

Forrest WW10407125

Test edge  with zero-clearance insert

Test edge  without zero-clearance insert

Melamine-coated particleboard, bottom face shown.

DeWalt DW7140PT

Test edge  with zero-clearance insert

Test edge  without zero-clearance insert

Crosscuts in birch-veneer plywood, bottom face shown.

10" GENERAL-PURPOSE TABLESAW BLADES

PRICE RANGE	MANUFACTURER	MODEL	TEETH BEVEL ANGLE, DEGREES	KERF WIDTH, INCHES	PERFORMANCE RATING (1)																SELLING PRICE	PHONE NUMBER		
					4/4 HARD MAPLE (2,3)				4/4 RED OAK (2,3)				8/4 HARD MAPLE (2,3)				8/4 RED OAK (2,3)		3/4" BIRCH PLYWOOD (3)				3/4" MELAMINE (4)	
					CROSSCUT SCORING	RIIP CUT TEAR-OUT	RIIP CUT SCORING	RIIP CUT TEAR-OUT	CROSSCUT SCORING	RIIP CUT TEAR-OUT	RIIP CUT SCORING	RIIP CUT TEAR-OUT	CROSSCUT SCORING	RIIP CUT TEAR-OUT	RIIP CUT SCORING	RIIP CUT TEAR-OUT	CROSSCUT SCORING	RIIP CUT TEAR-OUT	RIIP CUT SCORING	RIIP CUT TEAR-OUT			CROSSCUT SCORING	RIIP CUT TEAR-OUT

FULL-KERF BLADES (.125" or thicker)

\$97 OR MORE	FORREST	WW10407125	20	0.125	B+	A-	A-	A	A	A	B+	A	A	A-	A	A	A-	A	B+	A-	B-	A-	C	\$110	800-733-7111
	FREUD	P410	30	0.126	A-	A	B+	A	A	A	B+	A	A-	A	A-	A	A-	A	B+	A	B+	A	A	\$100	800-334-4107
	INFINITY	010-044	30	0.125	A	A	A-	A	A	A	A	A	A	A	B+	A	A	A	B+	A-	A	B+	B+	\$100	877-872-2487
	RIDGE CARBIDE	TS21040	15	0.125	B+	A	B-	A	A	A	B	A	A-	A	B	A	A	B	A	A	B-	A-	B+	\$97	800-443-0992
\$62 OR LESS	JESADA	110-440	20	0.126	C	B-	C	A	C	B	C	A-	D-	D	D-	B	C-	C	C	B	A-	B-	B	\$62	877-898-6657
	CM	213.040.10	20	0.130	B	A	C	A	B-	A	C	A	C	B	C-	A	B	A-	C+	A	C	A-	C	\$60	888-268-2487
	SYSTEMATIC	51821	20	0.125	B+	A	C-	A-	A-	A	C	A	B	B+	B	A	A	A-	B	A	B-	A-	C-	\$57	800-343-1616
	AMANA	610400	10	0.126	B-	B+	C+	A-	B-	A	B	A	C+	A	B	A	B	A-	B	A	C	A	B	\$55	800-445-0077
	ITP/H.O. SCHUMACHER	40-HATB-VP	40	0.125	B	A	C-	A	A-	A	C	A-	B+	A	C	A	B	B+	C	B	B	B+	B+	\$55	866-537-0700
	AMANA	PR1040	20	0.134	C+	A	C	A-	B+	A	B	A	C	A	B	A	B	A-	B	A	C	A	C-	\$52	800-445-0077
	BOSCH	PRO1040GP	15	0.128	C-	B	D	A-	C	A-	C-	A-	D	C-	D+	A	D	B	D	B-	C-	B	D+	\$45	877-267-2499

THIN-KERF BLADES (.118" or thinner)

\$90 OR MORE	FORREST	WW10407100	20	0.100	B+	B+	B	A	A-	A-	B	A	A-	A	A-	A	A-	A-	A	A	C-	A-	B	\$110	800-733-7111
	RIDGE CARBIDE	TS21040TK	15	0.093	A-	A	A-	A-	A-	A	B+	A	A-	B+	A	A	B+	A	A	A-	B	B	B+	\$97	800-443-0992
	TENRYU	GM-25540	15	0.111	B+	A	B	A	A	A	A	A	A	A	A	A	B+	A	A	A	A	A	B	\$90	800-951-7297
\$40 - \$65	AMANA	TB10400	10	0.090	C+	B+	C	A	B	A	B-	A-	B	A	B	A	B	A-	B	A	C	A-	B	\$65	800-445-0077
	SYSTEMATIC	37437	20	0.093	C	B	C	B	B	A-	B	A	C-	A-	C	A	C	B+	B-	A-	B	A-	B-	\$60	800-343-1616
	OLDHAM	1007740	10	0.115	D	B	C	A-	B-	A-	B	B+	D	C-	D	B	D	C-	D+	A-	B-	A-	C	\$50	800-433-9258
	DELTA	35-7657	15	0.118	C+	A-	B-	A	B	A-	C	A	B	A-	B	A	B	A-	B+	A	C	A-	C+	\$43	800-223-7278
	CMT	251.042.10	15	0.098	B	A	C-	A	B	A	C	A	B	A-	C	A	B-	A-	C	A	C	A-	B+	\$40	888-268-2487
	CRAFTSMAN	32808	15	0.100	A-	A	B-	A	A-	A	B	A	A-	A	B+	A-	B+	B+	B	B	C-	A-	C-	\$40	800-383-4814
	MAKITA	A-94459	15	0.091	C	A	C	A	B	A-	C	A	C	C	C	A-	B	B	C	A	C+	A-	B-	\$40	800-462-5482
\$35 OR LESS	DEWALT	DW7140PT	10	0.098	A-	A-	C-	A-	A-	B+	C	A	A-	A-	B	A	A-	A-	B-	A	C-	B+	C	\$35	800-433-9258
	FREUD	LU86R010	10	0.094	B+	A	B	A-	A	B	B	A	A	A	B	A	B+	B	B+	A	C+	A	D-	\$35	800-334-4107
	VERMONT AMERICAN	27831	12	0.098	C	D+	D	B	C-	C	C-	B	C	C	C	A-	D	C	D	C+	D+	D	D	\$35	800-626-2834
	FREUD	D1040X	15	0.098	B+	B+	B+	A-	A-	B+	B	A	A-	A	B+	A	A-	A-	B+	A	C+	A-	C-	\$30	800-334-4107
	HITACHI	310878	20	0.098	C	B	B	A-	B	A-	B	A	C-	B-	B-	A-	C	B	B	B	C+	C	D+	\$30	800-829-4752
	DEWALT	DW3114	10	0.095	B+	A-	B-	A-	A-	B-	B+	A-	B+	B+	A-	A	B+	B-	B+	B	C-	B-	D+	\$28	800-433-9258
	IRWIN MARATHON	14070	10	0.095	B	C-	C-	B-	B+	C	C-	B	C	C	D	B	B	D	C	C-	D-	D	D-	\$28	800-464-7946



Full-Kerf Blades



CONTACT INFORMATION

WEB SITE

forrestblades.com
freudtools.com
infinitytools.com
ridgecarbideool.com
razorwoodworks.com
cmtusa.com
simondsinternational.com
amanatool.com
itptooling.com
amanatool.com
boschttools.com

forrestblades.com
ridgecarbideool.com
tenryu.com
amanatool.com
simondsinternational.com
oldham-usa.com
deltaportercable.com
cmtusa.com
craftsman.com
makitools.com
dewalt.com
freudtools.com
vermontamerican.com
freudtools.com
hitachipowertools.com
dewalt.com
irwin.com

Grade samples:
(Blue chalk used to show scoring)
8/4 hard maple rip cuts



4/4 red oak crosscuts



birch-veneer plywood crosscuts
(Top edges are test edges, bottom face shown)



NOTES:

- | | |
|---|-----------|
| A | Excellent |
| B | Good |
| C | Fair |
| D | Poor |
- BLADE SCORING EVALUATION CRITERIA**
Maple, Red Oak

 - A = Absence of blade marks; joint-ready
 - B = Blade marks can be removed with light sanding
 - C = Blade marks can be removed with heavy sanding
 - D = Blade marks can be removed with jointer or hand plane
- TEAR-OUT EVALUATION CRITERIA**
Maple, Red Oak, Birch Plywood

 - A = No tear-out on top and bottom faces
 - B = No tear-out on top face, slight tear-out on bottom face
 - C = Little to no tear-out on top face, significant tear-out on bottom face
 - D = Consistent tear-out on top face, significant tear-out on bottom face
- CHIP-OUT EVALUATION CRITERIA**
Melamine

 - A = No chipping on top and bottom faces
 - B = No chipping on top face, slight chipping on bottom face
 - C = Little to no chipping on top face, significant chipping on bottom face
 - D = Consistent chipping on top face, significant chipping on bottom face

15° beveled teeth on the Ridge Carbide TS21040. So we're also recommending the Forrest blade for work in solid stock, though if used without a zero-clearance insert it will produce more tear-out or chip-out in plywood or melamine than the Freud or Infinity blades.

Full-kerf blades priced \$62 or less:

The Amana 610400 and Systimatic 51821 scored best, earning Top Value recognition. Both blades produced some chip- or tear-out on the bottom face of sheet goods, and will do better if you use a zero-clearance insert and feed the material slowly.

Thin-kerf blades priced \$90 or more:

Top Tool honor goes to the Tenryu GM-25540. It costs less and performs slightly better than the other two blades in this group. But, if kerf thinness is paramount, note that the Forrest WW10407100 and Ridge Carbide TS21040TK are slightly thinner than the Tenryu.

Thin-kerf blades priced \$40-\$65:

The Craftsman 32808 had higher grades overall than the other blades in this category and price range. Here, too, a zero-clearance insert will noticeably improve your results on the bottom side of sheet goods.

Thin-kerf blades priced \$35 or less:

The Freud D1040X was the best value in the test, scoring within an eyelash of the Craftsman 32808. If you're on a budget, here's a blade that earns an A or B grade in every cut except sheet goods where you'll need a zero-clearance insert for improved bottom-side results.

Thin-Kerf Blades



Drawers Sized to Suit Shop Organizer



Keep hardware, supplies, and small hand tools at the ready in this easy-to-build drawer cabinet.

If you've ever said to yourself, "I know I have the perfect tool [or hardware] for the job; now, if I could just lay my hands on it," stop mumbling and build one or more of these handy cabinets.

Build the case

1 Cut the top and bottom (A), sides (B), and divider (C) to size [Materials List, page 50]. (We used $\frac{3}{4}$ " medium-density fiberboard [MDF].)

2 Install a dado blade in your table saw. Cut $\frac{1}{4}$ " rabbets along the rear edges of the top and bottom (A) and sides (B) and the top ends of the sides and divider

(C) [Drawings 1 and 1a]. Then cut $\frac{1}{2}$ " rabbets along the ends of the top and bottom and the front edges of the sides and divider (C). Finally cut $\frac{5}{8}$ " rabbets along the bottom ends of the sides and divider. For a quick and safe way to set up your table saw when cutting rabbets, see page 34.

3 With a $\frac{1}{4}$ " dado blade in your table saw, cut centered dadoes into the top and bottom (A), and drawer-slide dadoes in the sides (B) and divider (C) [Drawings 1 and 1a]. To guarantee accurate placement of the drawer-slide dadoes, see the Shop Tip on the next page.

PROJECT HIGHLIGHTS

- Overall dimensions: 20 $\frac{3}{4}$ " wide x 12" deep x 21 $\frac{5}{8}$ " high.
- Super-simple drawers with built-in slides go together in a snap.
- The organizer shown has three small, two medium, and three large drawers. But the modular drawer design lets you build in the mix of sizes that works best for you. (It'll hold up to 16 small drawers.)

Skill Builders

- Learn how a cutting guide called a story stick helps you avoid mistakes.
- Discover how an ancient method can solve modern clamping challenges.

4 Glue and clamp the case with the parts flush at the front, checking for square. After the glue dries, remove the clamps, and sand the joints smooth.

5 Cut the glides (D) to size, and glue and clamp them in place [Drawing 1]. The glide ends align with the rabbet shoulders along the front and rear edges of the sides (B) and divider (C). For a simple way to apply clamping pressure to the glides, see the Shop Tip on page 50.

6 Cut the back (E) to size, and glue and clamp it in place.

Make the drawers

1 Cut the bottoms (F) to size. Check the fit into the case dadoes to make sure they slide easily.

2 Cut the drawer fronts (G, J, M), sides (H, K, N), and backs (I, L, O) to size, and finish-sand them. Cut dadoes into the fronts to accept the sides, and a rabbet to accept the bottom (F). Then cut rabbets into the sides to accept the backs [Drawing 2]. Glue and clamp the drawer boxes [Photo A]. After the glue dries, sand the joints smooth.

3 Glue and clamp the bottoms (F) to the drawer boxes (G/H/I, J/K/L, and M/N/O). Make sure the bottoms are fully seated into the front (G, J, M) rabbets and centered side-to-side.

Apply finish and assemble

1 Apply a clear finish. (We applied two coats of Minwax Satin Polyacrylic, lightly sanding between coats with 220-grit sandpaper.)

2 After the finish dries, drill pilot holes and screw the card-holder pulls in place [Drawing 2]. (For the #6 screws, drill $\frac{3}{32}$ " pilot holes.) Apply paste wax to the edges of the drawer bottoms (F), the side (B) and divider (C) grooves, and the glides (D). Slide the drawers into

continued on page 50

ASSEMBLE THE DRAWER BOXES

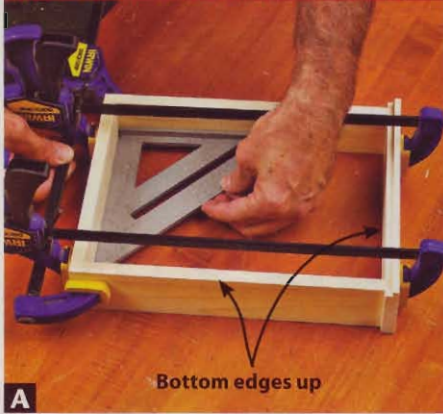

Bottom edges up

A With the parts upside down on a flat surface, glue and clamp the drawer boxes flush at the top, and check them for square.

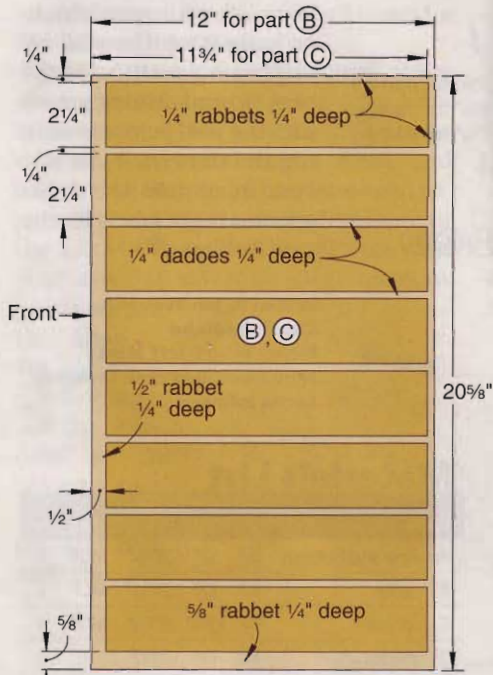

(Part **B** has rabbets and dados cut on one side only. Part **C** has rabbets and dados on both sides.)

1a SIDE AND DIVIDER

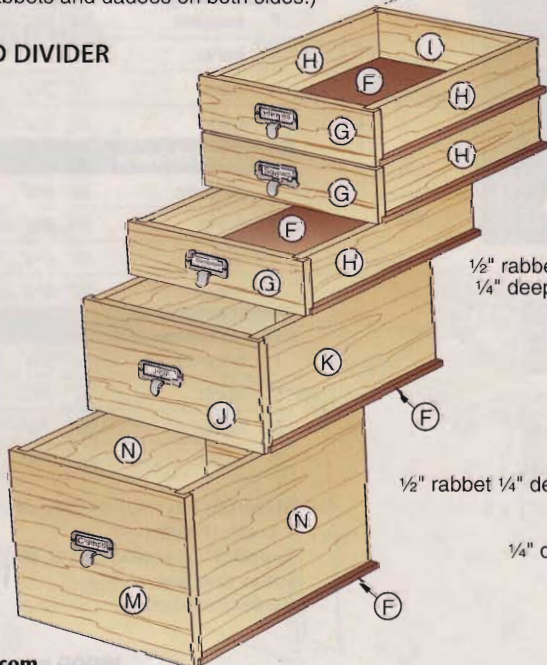

SHOP TIP

A story stick ensures no-fault dado layout

When cutting drawer-side dados into the sides (**B**) and divider (**C**), to avoid a mistake, such as cutting on the wrong side of a layout line, make a simple setup guide called a story stick. Here's how:

Cut a strip of scrapwood the length of the parts. (We cut a $3 \times 20 \frac{5}{8}$ " piece of $\frac{3}{4}$ " MDF.) For clarity, apply masking tape to one edge of the strip, and then lay out both edges of each dado on the tape. Also, mark the $\frac{1}{4}$ " top rabbet and $\frac{5}{8}$ " bottom rabbet.

Install a $\frac{1}{4}$ " dado blade in your tablesaw and adjust it to cut $\frac{1}{4}$ " deep. Guiding the strip with the miter gauge, and using the rip fence as a stop, cut a dado at each marked location. Check your story stick for accuracy. (It's easier to make a new story stick than a new divider and



sides.) Now in succession, place the story-stick dados over the blade, as shown above, and position the rip fence against the end of the story stick. Cut dados in the sides and both faces of the divider at each fence location.

1 EXPLODED VIEW

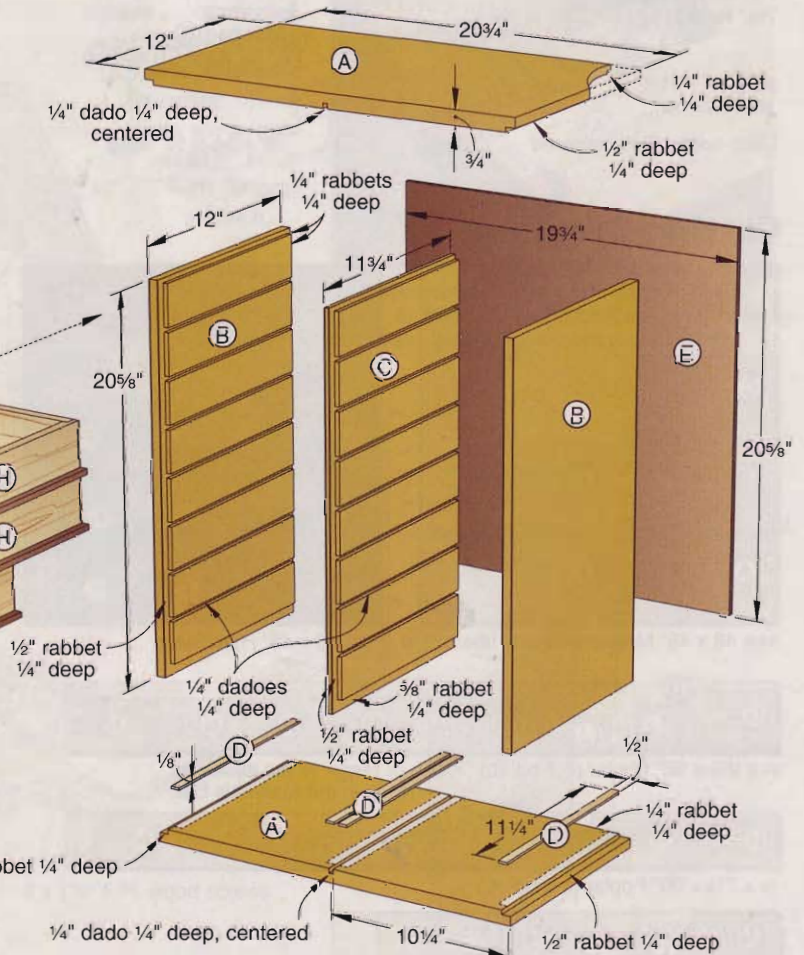

SHOP TIP

Go-bars: an ancient, go-to clamping solution

Using a "go-bar" deck—flexible sticks bent between two solid surfaces—is a very old method of applying clamping pressure. In early shops, poles bent against the ceiling were used to apply pressure to a benchtop. Because of the difficulty of applying pressure to the center of a large panel, this method has always been used to clamp and glue parts onto harpsichord, and later piano, soundboards.

To use this method for clamping the glides (D) to the case bottom (A), rip $\frac{1}{4}$ "-thick strips from the edge of a $20\frac{1}{8}$ "-long piece of $\frac{3}{4}$ " MDF. (You can use a thin strip of any hardwood, softwood, or plywood scrap.) Then apply glue and position the glides. Now insert the MDF strips with the bottom ends bearing on the glides and the top ends bowed against the case top (A), as shown at right.

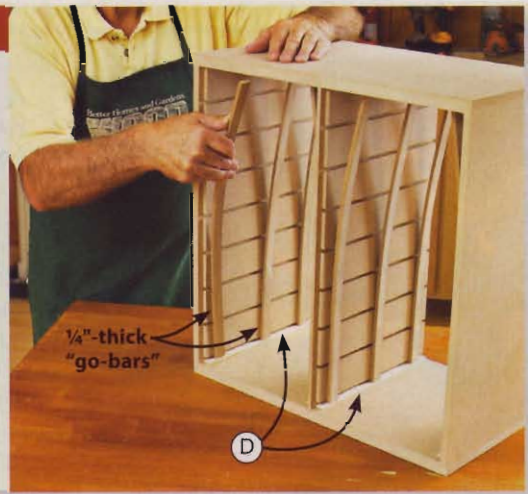

2 DRAWER

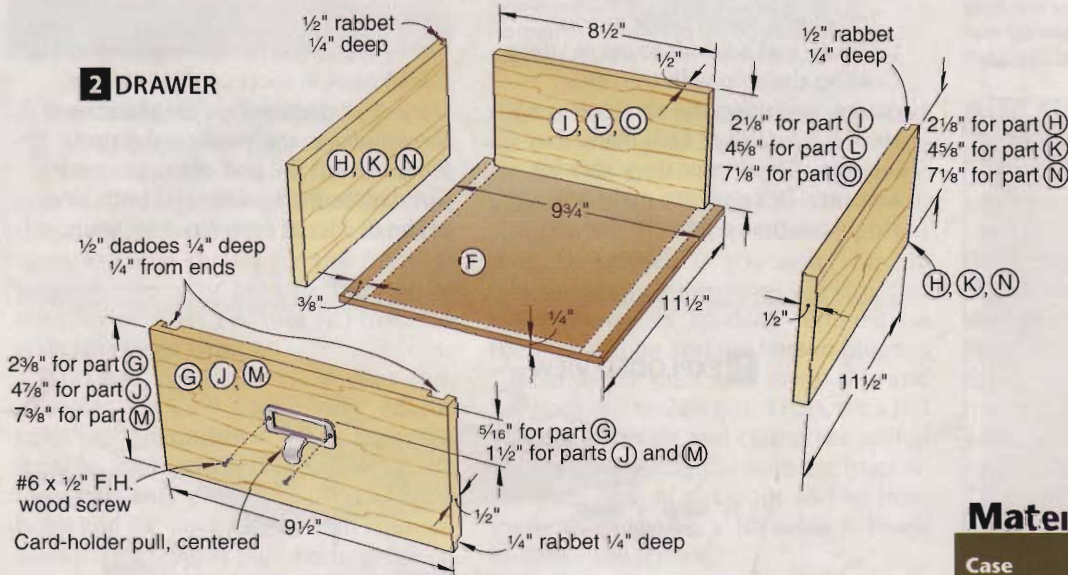

the case. Place the organizer on your workbench, or hang it on the wall by drilling holes through the back (E) and driving screws into the wall before installing the drawers. Now sort your items into the drawers, and make labels for the card holders. 🌲

Written by **Jan Svec** with **Chuck Hedlund**
Project design: **Jeff Mertz**
Illustrations: **Roxanne LeMoine;**
Lorna Johnson

Cutting Diagram

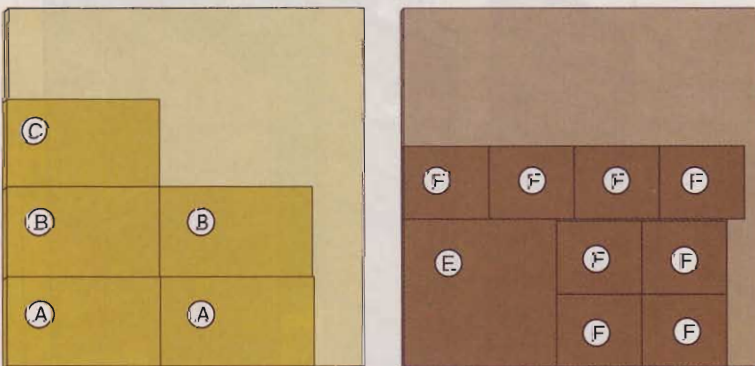

$\frac{3}{4}$ x 48 x 48" Medium-density fiberboard $\frac{1}{4}$ x 48 x 48" Hardboard

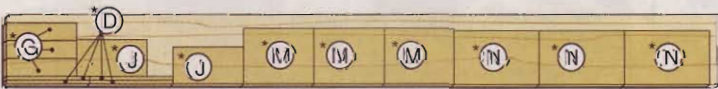

$\frac{3}{4}$ x $9\frac{1}{4}$ x 96" Poplar (6.7 bd. ft.) *Plane or resaw to the thickness listed in the Materials List.

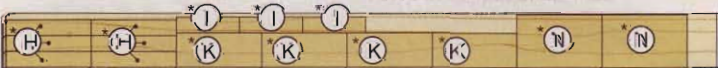

$\frac{3}{4}$ x $7\frac{1}{4}$ x 96" Poplar (5.3 bd. ft.)



$\frac{3}{4}$ x $7\frac{1}{4}$ x 60" Poplar (3.3 bd. ft.)

Materials List

Case	FINISHED SIZE			Matl.	Qty.
	T	W	L		
A top and bottom	$\frac{3}{4}$ "	12"	$20\frac{3}{4}$ "	MDF	2
B sides	$\frac{3}{4}$ "	12"	$20\frac{5}{8}$ "	MDF	2
C divider	$\frac{3}{4}$ "	$11\frac{3}{4}$ "	$20\frac{5}{8}$ "	MDF	1
D glides	$\frac{1}{8}$ "	$\frac{1}{2}$ "	$11\frac{1}{4}$ "	P	4
E back	$\frac{1}{4}$ "	$19\frac{3}{4}$ "	$20\frac{5}{8}$ "	H	1

Small drawer

F bottoms	$\frac{1}{4}$ "	$9\frac{3}{4}$ "	$11\frac{1}{2}$ "	H	3
G fronts	$\frac{1}{2}$ "	$2\frac{3}{8}$ "	$9\frac{1}{2}$ "	P	3
H sides	$\frac{1}{2}$ "	$2\frac{1}{8}$ "	$11\frac{1}{2}$ "	P	6
I backs	$\frac{1}{2}$ "	$2\frac{1}{8}$ "	8 $\frac{1}{2}$ "	P	3

Medium drawer

F bottoms	$\frac{1}{4}$ "	$9\frac{3}{4}$ "	$11\frac{1}{2}$ "	H	2
J fronts	$\frac{1}{2}$ "	$4\frac{7}{8}$ "	$9\frac{1}{2}$ "	P	2
K sides	$\frac{1}{2}$ "	$4\frac{5}{8}$ "	$11\frac{1}{2}$ "	P	4
L backs	$\frac{1}{2}$ "	$4\frac{5}{8}$ "	8 $\frac{1}{2}$ "	P	2

Large drawer

F bottoms	$\frac{1}{4}$ "	$9\frac{3}{4}$ "	$11\frac{1}{2}$ "	H	3
M fronts	$\frac{1}{2}$ "	$7\frac{3}{8}$ "	$9\frac{1}{2}$ "	P	3
N sides	$\frac{1}{2}$ "	$7\frac{1}{8}$ "	$11\frac{1}{2}$ "	P	6
O backs	$\frac{1}{2}$ "	$7\frac{1}{8}$ "	8 $\frac{1}{2}$ "	P	3

Materials key: MDF—medium-density fiberboard, P—poplar, H—hardboard.

Supplies: Card-holder pulls (8), #6x $\frac{1}{2}$ " flathead wood screws, paste wax.

Blade: Stack dado set.

Retro Rockin'

Knock-down Bed



Young adults seem to love the unusual shapes and vivid colors of mid-20th-century modern design. And whether they're in college or starting a career, they tend to move around. They'll flip over the design of this twin bed and how it knocks down flat to easily fit into the back of a minivan.

PROJECT HIGHLIGHTS

- Overall dimensions: 47 $\frac{3}{4}$ " wide x 76 $\frac{1}{2}$ " long x 40 $\frac{1}{4}$ " high. Fits a 9x39x75" twin mattress.
- This project uses two sheets of Baltic birch plywood with just a few small scraps and sawdust left over. Thin veneers and freedom from voids give the edges of Baltic birch plywood an attractive appearance that doesn't need to be covered with solid-wood edging or veneer tape.
- Apply a unique semitransparent finish with inexpensive materials you can purchase at a hardware store. (See page 26.)
- To save money, build the project from regular birch plywood, fill any edge voids, and apply the semitransparent finish. Or use MDF, and paint it.

Skill Builders

- Discover the ease of using cross-dowel and connector-bolt hardware to construct knock-down furniture.
- Learn how to use a dowel jig to drill accurate holes for connector bolts.

Build the base

1 Cut two sheets of $\frac{3}{4}$ " Baltic birch plywood to the sizes shown on the **Cutting Diagram** on page 56 [Photo A]. For a handy guide for positioning your straightedge, see page 32. Now use your tablesaw to cut the parts, except for the feet (B), panel (E), and headboard (G), to size [Materials List]. Cut 10 $\frac{1}{2}$ "x10 $\frac{1}{2}$ " blanks for the feet, and cut the headboard piece to 30" long. Use a circular saw and straightedge to trim the panel to size. (For instructions on making a dual-purpose straightedge for your circular saw and router, see page 84.)

2 For easy assembly and disassembly, cut the notches in the leg sides (A) that accept the long stretchers (C) and short stretchers (D) about $\frac{1}{16}$ " wider than the plywood thickness [Drawing 1, Photos B and C]. (Our plywood measured slightly over $\frac{1}{16}$ " thick, so we made the notches $\frac{3}{4}$ " wide.) Then cut $\frac{1}{8}$ "-deep grooves in eight of the leg sides with a dado blade, and rout $\frac{1}{16}$ " chamfers along

the edges. Finish-sand the parts, including the edges of the grooved sides. Glue and clamp the legs, checking for square and keeping the ends flush.

3 Draw diagonals onto each foot (B) blank to find the center. Then draw 3 $\frac{1}{8}$ "- and 5"-radius circles on each one [Drawing 1a]. Lay out four hole centers on each inner circle and drill shank holes. (For the #8 screws, drill $\frac{5}{32}$ " shank holes and $\frac{7}{64}$ " pilot holes.) Bandsaw and sand the parts to the outer circle. Now rout $\frac{1}{8}$ " chamfers along the bottom edge and $\frac{1}{16}$ " chamfers along the top edge of each foot, and finish-sand them.

4 To center the leg side (A) assemblies onto the feet (B), cut an alignment block to snugly fit inside the leg side assemblies. (We cut a $\frac{3}{4}$ "x3 $\frac{3}{4}$ "x5 $\frac{1}{2}$ " block.) Draw diagonals onto the block to find the center, and drill a shank hole. Then drill a pilot hole into the center of each foot. Screw the block to one foot, position the foot on a leg side assembly, and drill pilot holes into the leg sides [Photos

ATTACH THE FEET TO THE LEG SIDES

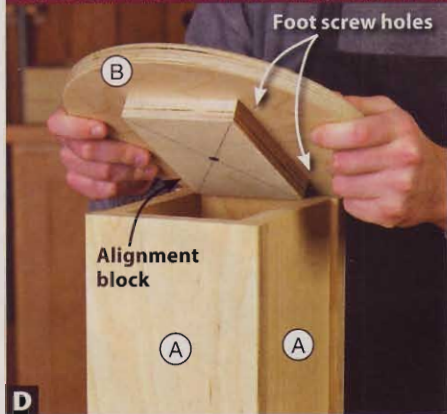

D With a block screwed to a foot (B), and aligned with the foot screw holes, position the foot on a leg side (A) assembly.

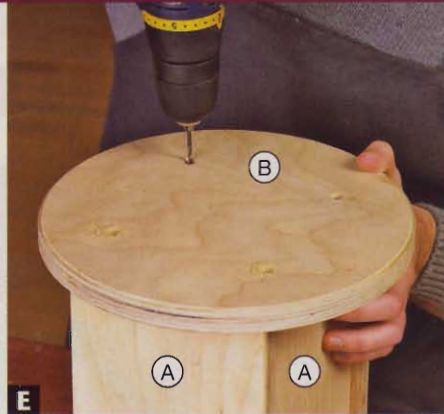

E With the foot (B) seated on the leg side (A) assembly, use the holes in the foot as guides, and drill pilot holes into the leg sides.

6 For the cross dowels and connector bolts that secure the sides (F), headboard (G), and footboard (H) to the long stretchers (C) and short stretchers (D) [Drawing 3], drill 10mm cross-dowel holes $\frac{5}{8}$ " deep and $\frac{3}{32}$ " connector-bolt holes 3" deep at both ends of each stretcher [Drawing 2 and Photos F, G, H,

and I]. (See Sources for connector bolts, cross dowels, a 10mm Forstner bit, and a self-centering dowel jig.)

Note: Connector-bolt and cross-dowel holes must align precisely. Use a combination square as a marking gauge when laying out the 10mm hole locations, and mark the centers with an awl before drilling.

DRILL CROSS-DOWEL AND CONNECTOR-BOLT HOLES

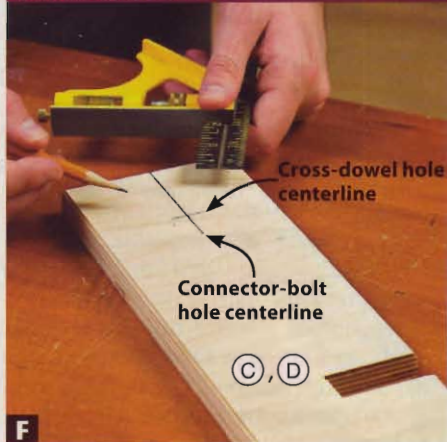

F Using a combination square, mark the centerline of the $\frac{3}{32}$ " connector-bolt hole and the center of the 10mm cross-dowel hole.



G After marking the cross-dowel hole center with an awl, drill the hole on the drill press with a 10mm Forstner bit.



H Using a dowel jig to center a $\frac{1}{4}$ " bit on the plywood edge and align it with the centerline, drill a hole as deep as the bit allows.



I After removing the dowel jig, chuck a $\frac{3}{32}$ " bit into a handheld drill, enlarge the $\frac{1}{4}$ " hole, and extend it to a depth of 3".

Make the platform

1 Lay out 10mm cross-dowel hole centers on the panel (E) [Drawing 4]. Drill these holes and the intersecting $\frac{3}{32}$ " connector-bolt holes the same way as with the stretchers (C, D).

2 Lay out and drill the 10mm cross-dowel holes and the $\frac{3}{32}$ " and $\frac{1}{4}$ " connector-bolt holes in the sides (F), and the $\frac{1}{4}$ " connector-bolt holes in the headboard (G) and footboard (H) [Drawings 3, 5, 6, and 7]. Be sure to make two right-hand and two left-hand sides.

3 Using a straightedge to guide a handheld plunge router fitted with a $\frac{3}{4}$ " straight bit, rout a $\frac{1}{8}$ "-deep dado in the inside face of each side (F) [Drawing 5]. Then mark the ends of the stopped dados in the headboard (G) and footboard (H) [Drawings 6 and 7], and rout the dados. Square the ends of the stopped dados with a chisel. (For tips on routing stopped dados and grooves, see page 30.)

4 Rout the short grooves in the sides (F), headboard (G), and footboard (H) with a straightedge and handheld router. Remember to make two right and two left sides.

5 Draw the 3" and 6" radii on the sides (F) and the 3" radii on the footboard (H). Cut within $\frac{1}{8}$ " of the lines with a jigsaw. Then make corner-routing jigs [Drawing 8], and rout the radii to the lines [Photo J].

6 Lay out the shape of the headboard (G), and mark the centers of the 2", 4", and 6" holes. Cut the side and top angles with a circular saw and straightedge. Jigsaw and sand the 2" radii at the top corners.

Note: If you wish, you may mirror the shape of the headboard to fit room layout, or to make complementary side-by-side beds for the same room.

7 Using a roller stand to support the headboard on your drill press, drill a $\frac{1}{4}$ " hole at the center of the 2", 4", and 6" circles. Then clamp the headboard to the drill-press table, and use an adjustable circle cutter to cut the circles. To prevent tear-out, cut two-thirds of the way through the headboard from one side, flip the piece, and complete the cut from the other side.

8 Rout $\frac{1}{16}$ " chamfers along all ends and edges of the platform parts E, F, G, and H, including the edges of the holes in the headboard (G). Finish-sand the parts, including the edges.

continued on page 56

3 EXPLODED VIEW

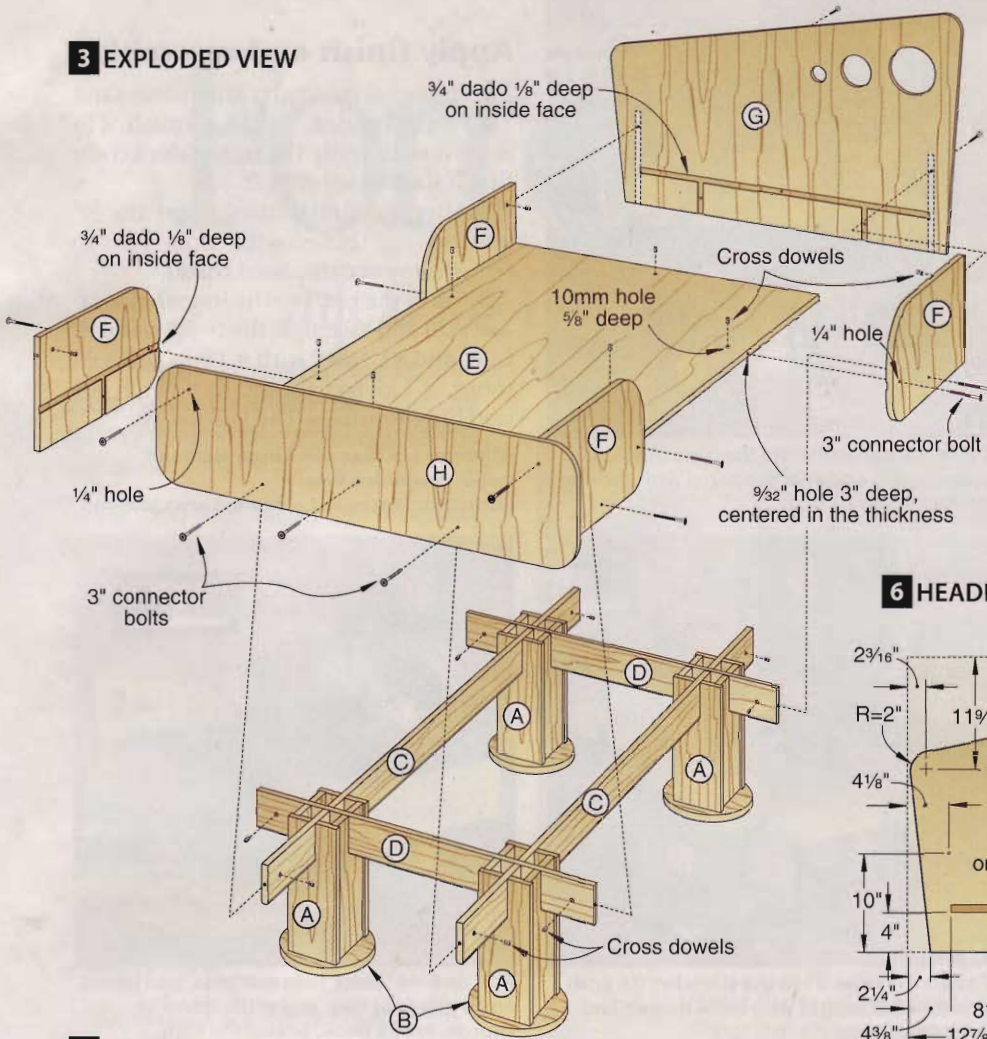

ROUT THE CORNER RADII

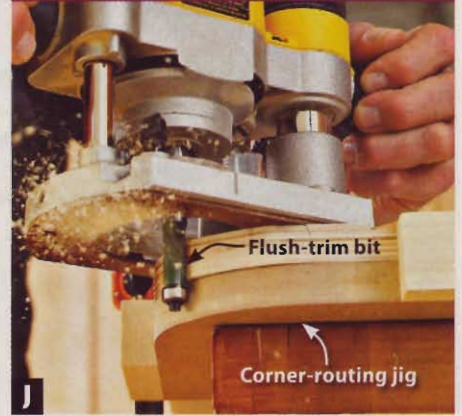

After jigsawing close to the radius line, true up the radius with a corner-routing jig and a handheld router fitted with a flush-trim bit.

4 PANEL

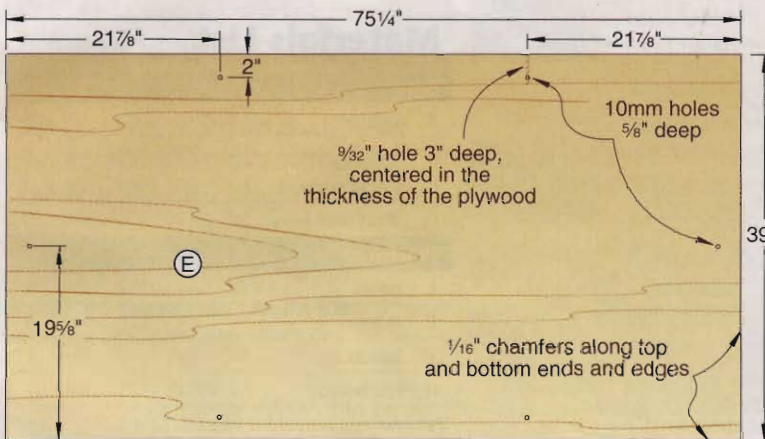

5 SIDE

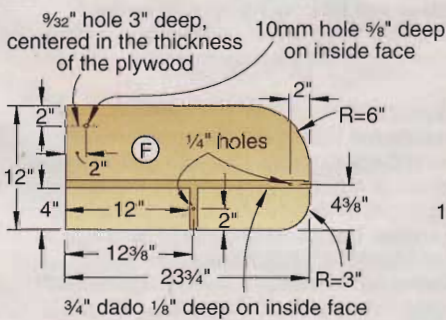

6 HEADBOARD

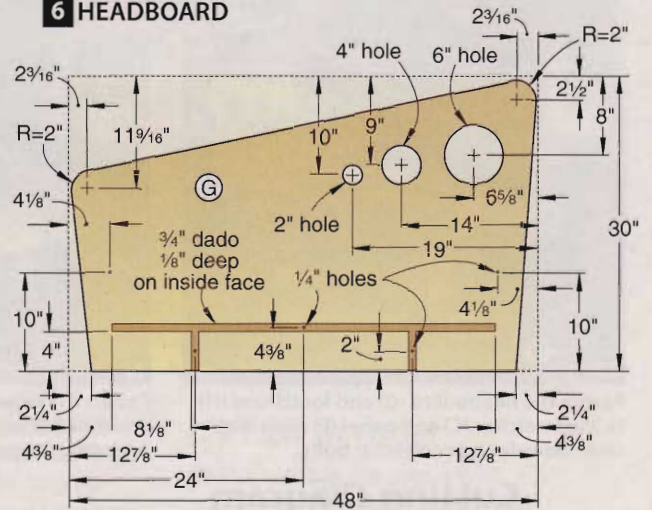

7 FOOTBOARD

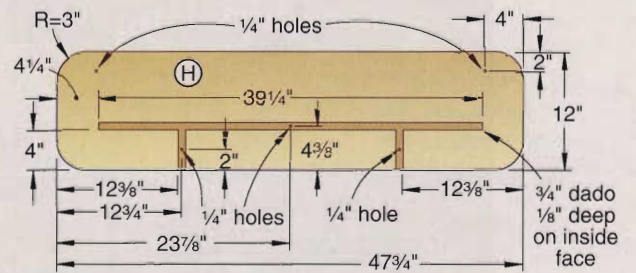

8 RADIUS JIGS

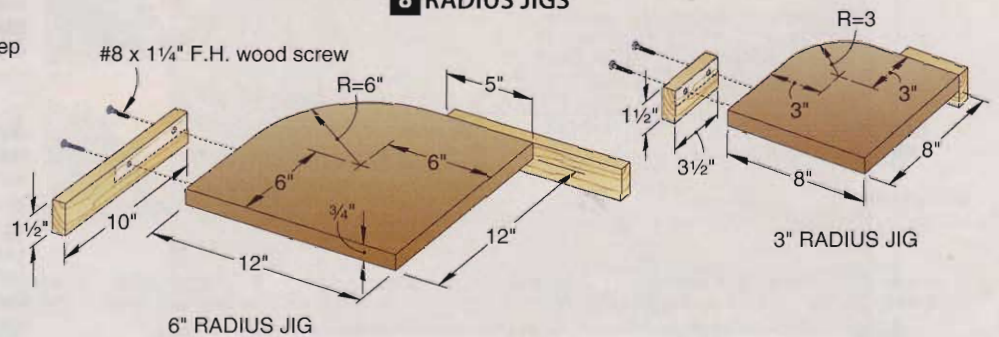

ASSEMBLE THE BED



K With the long stretchers (C) in the leg (A/B) slots, drop the short stretchers (D) into place, interlocking the stretcher notches.



L Place the panel (E) onto the base (A/B/C/D), aligning the edges of the panel with the ends of the stretchers (C, D).



M Fasten the headboard (G) and footboard (H) to the stretcher (C) and panel (E) ends with cross dowels and connector bolts.



N Fasten the sides (F) to the stretcher (D) ends and panel (E) edges with cross dowels and connector bolts.

Apply finish and assemble

1 Inspect all the parts and finish-sand where needed. Apply a finish. (To learn how to apply the transparent color finish shown, see page 26.)

2 After the finish dries, ream the $\frac{1}{4}$ " and $\frac{3}{32}$ " holes with drill bits to remove any accumulated finish.

3 Carry the parts to the intended location and assemble the bed [Photos K, L, M, and N]. Now, with a TV in the bedroom, a kid has the perfect perch for watching reruns of *The Jetsons*. 🌳

Written by **Jan Svec** with **Chuck Hedlund**

Project design: **Jan Svec**

Illustrations: **Roxanne LeMoine; Lorna Johnson**



Add an 8–10"-thick twin mattress, bed linens, and a pillow or two, and settle down to snooze, read a book, or surf the Web.

Cutting Diagram

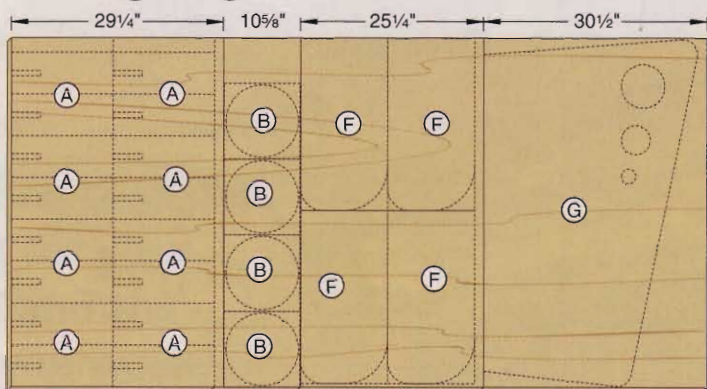

$\frac{3}{4}$ x 48 x 96" Baltic birch plywood

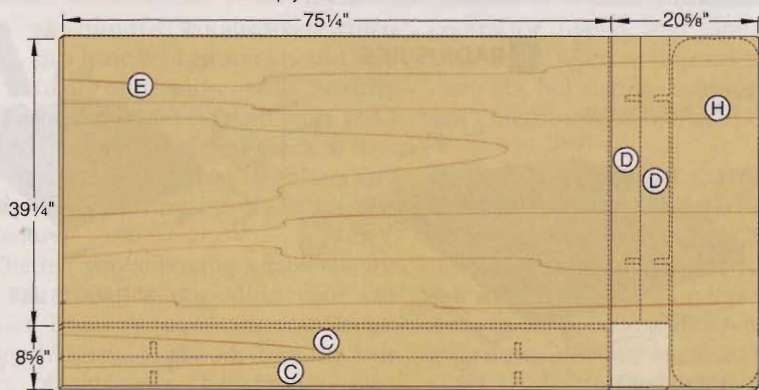

$\frac{3}{4}$ x 48 x 96" Baltic birch plywood

Materials List

Base	FINISHED SIZE			Matl.	Qty.
	T	W	L		
A leg sides	$\frac{3}{4}$ "	5 $\frac{3}{4}$ "	14"	BBP	16
B* feet	$\frac{3}{4}$ "	10" diam.		BBP	4
C long stretchers	$\frac{3}{4}$ "	4"	75 $\frac{1}{4}$ "	BBP	2
D short stretchers	$\frac{3}{4}$ "	39 $\frac{1}{4}$ "	4"	BBP	2
Platform					
E panel	$\frac{3}{4}$ "	39 $\frac{1}{4}$ "	75 $\frac{1}{4}$ "	BBP	1
F sides	$\frac{3}{4}$ "	23 $\frac{3}{4}$ "	12"	BBP	4
G* headboard	$\frac{3}{4}$ "	47 $\frac{5}{8}$ "	29 $\frac{1}{2}$ "	BBP	1
H footboard	$\frac{3}{4}$ "	47 $\frac{3}{4}$ "	12"	BBP	1

*Part initially cut oversize. See the instructions.

Material key: BBP—Baltic birch plywood.

Supplies: #8x2" flathead wood screws (16).

Blade and bits: Stack dado set; $\frac{1}{2}$ " straight, $\frac{3}{4}$ " straight, $\frac{1}{4}$ " round-over, and 45° chamfer router bits; 10mm Forstner bit; adjustable circle cutter.

Sources

Hardware: $\frac{1}{4}$ -20x3" brass-plated connector bolts no. 1430-KDB, \$7.13 pack of 25; 10mm-diam. $\frac{1}{4}$ -20 cross dowels no. 0609-CDA, \$6.78 pack of 25. 4mm hex wrench no. 8501-PD, \$1.40. McFeely's, 800-443-7937, mcfeelys.com.

Forstner bit: 10mm Forstner bit no. 06J72.10, \$6.30. Lee Valley, 800-871-8158, leevalley.com.

Dowel jig: Self-centering dowel jig no. G1874, \$31.95. Grizzly Industrial, 800-523-4777, grizzly.com.

How to Buy a Tablesaw



Get one that's right for your shop and the way you work.

Tools Editor Bob Hunter tried out a number of tablesaws for this article, and turns that into buying advice for you.

Ask a hundred woodworkers which machine a beginner should buy first, and most will heartily recommend a tablesaw. And with good reason: It's ideal for sawing stock to size, getting it square, machining miters and bevels, and cutting nearly all types of joinery.

Whether you're buying a tablesaw for the first time or upgrading your old clunker, begin by narrowing your focus. First, you'll have to choose from the four types of tablesaws: benchtop/job-site,

contractor, hybrid, and cabinet. Any of these saws, when well-tuned, make accurate cuts, but step-up features increase a saw's usefulness, as well as its cost.

8 key factors to consider when buying a tablesaw

■ **Power.** If you regularly work with hardwoods more than 3/4" thick, get a saw with at least a 1½-hp motor. (It takes 3 hp to make heavy cuts with no bogging down.) Totally enclosed fan-cooled (TEFC) induction motors run cooler and

quieter than the universal motors typically found on benchtop/job-site saws.

■ **Electrical service.** Tablesaws with 2-hp or larger induction motors typically require 220-volt service. Know your shop's power capabilities before you buy, or be willing to add a 220 line. Also, consider what machines you'll operate at the same time, such as a dust collector, so you don't overload circuits.

■ **Price.** You can pay anywhere from \$150 for a benchtop saw to well over \$3,000 for a professional-level cabinet

RIVING KNIFE PREVENTS KICKBACK



A riving knife attaches behind the blade and moves up and down with it. This device holds the kerf open and prevents kickback.

saw. As the woodworkers' creed says, "Get all the tool you can afford."

■ **Capacity.** All tablesaws feature at least a 10"-diameter blade, but tabletop sizes vary greatly. And maximum rip capacity ranges from 1' to over 4', an important consideration if you work regularly with sheet goods.

■ **Safety.** Some saws include better safety guards and features (anti-kickback riving knives, blade-brake technology) than others, but often at a higher price tag. For example, a riving knife, shown *above*, keeps boards from pinching against the back edge of the blade, thus preventing kickback. A few saws have this feature now, and many more will in the next few years, as manufacturers comply with new safety regulations. Blade-brake technology, available exclusively on models from SawStop, almost instantly stops a spinning blade should a hand or finger come into contact. It could mean a small cut instead of an amputation.

■ **Space.** If you work in a small garage or basement, your shop might not accommodate a tablesaw with 7' fence rails. Instead, opt for a more compact machine with a rip capacity of 30" or less. In addition to the footprint of the machine, you'll need to leave infeed and outfeed space for ripping long workpieces, and side space for crosscutting long stock. Don't let a too-big tablesaw eat up the very space you need to work in.

■ **Dust control.** Cutting wood creates dust, but not all tablesaws can control it. Closed-base saws with dust ports prove most effective at channeling debris to a dust collector, while many open-base contractor and benchtop/job-site saws simply let the dust fly.

■ **Availability and service.** Online dealers can ship a tablesaw to your shop, but will they provide parts should it break down? You might prefer to buy from a local retailer if you're not confident in making your own repairs.



Cabinet saws deliver powerful performance

Just as automobile enthusiasts dream of luxury vehicles or speedy sports cars, woodworkers long for cabinet-style tablesaws. With heavy-duty components and 3-hp motors, these machines slice through wood like it's pudding, yet deliver and maintain pinpoint accuracy when set up correctly. The term "cabinet saw" comes from the enclosed steel base that enhances dust collection as well as reduces blade and motor noise, though not all tablesaws with cabinets belong in this group. The saw of choice for professional woodworking shops, this will cost you at least \$1,000 for a new machine.

A typical 3-hp cabinet tablesaw weighs 500 lbs or more because of its big motor and cast-iron components. (Pro models feature 5-, 7½-, or 10-hp motors and also can have 12" or 14" blades.) The motor, mounted below the blade inside the cabinet, drives the blade with either two or three V-belts or one wide, ribbed flat belt.

To harness this kind of power, cabinet saws feature an all-cast-iron inner structure (yoke, trunnions, gears). The large trunnions mount to the cabinet, shown *above right*, rather than to the cast-iron top, as with other tablesaw styles. This is an advantage because adjusting the top parallel to the blade—necessary for accurate cuts—requires loosening only three of the four bolts that connect it to the cabinet and pivoting the top.

Cabinet-style saws typically come with fence rails that provide 50–54" of rip capacity—mighty handy for working with 4×8' sheet goods. Don't need that much? You can get one instead with 30"-capacity rails, an attractive option for small shops. Most cabinet saws feature T-square-style fences with heavy-duty rails.

THIS SAW'S BUILT FOR TOUGH USE

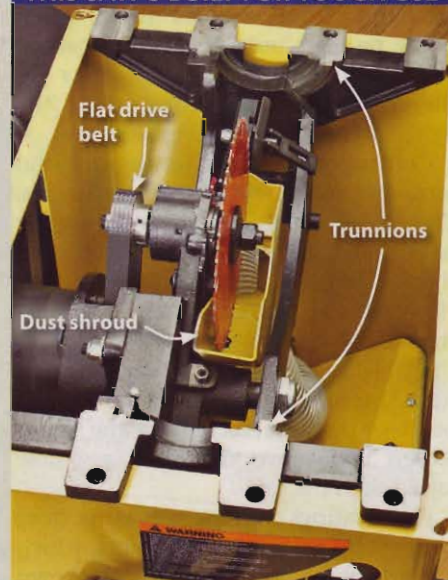

Heavy-duty trunnions provide durability and accuracy, and also dampen vibration.

Pros:

- Powerful motor for bog-free cuts
- Trunnions mount to cabinet for easy, long-lasting table adjustments
- Heavy-duty fence and rails
- Large rip capacity
- Enclosed base improves dust collection
- Large, comfortable handwheels
- Low blade and motor noise levels
- Typically, a large power switch in an easy-to-reach location
- A few models have built-in or included mobile bases

Cons:

- Prices start at around \$1,000
- Requires 220-volt electrical service
- Heavy, so mobility is limited
- Large footprint on saws with long fence rails

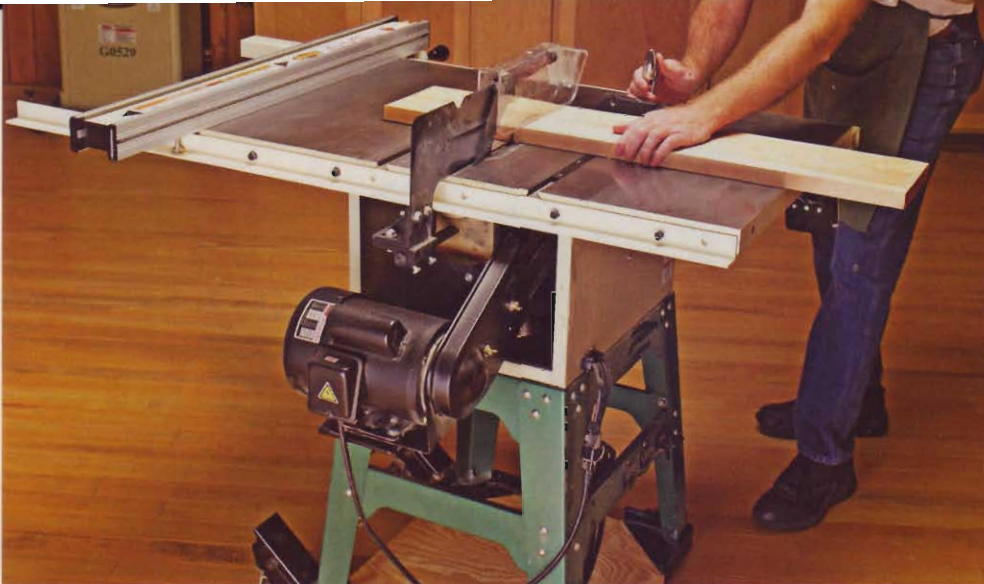

These tablesaws aren't just for contractors

The contractor-style tablesaw gets its name from decades back, when home builders used them on location. Today, you'll seldom see one on a job site, thanks to the evolution of the lighter-weight benchtop/job-site saw.

Contractor-style saws feature cast-iron tops, and most now include cast wings. This added vibration-dampening weight helps hold an accurate setup longer than a saw with stamped-steel wings. However, the trunnions, much smaller than those on a cabinet saw, mount to the tabletop from below, as shown *above right*. This makes alignment more difficult because you must reach inside the saw to loosen and move the arbor assembly rather than the top.

Power ratings on these saws range from 1½ to 2 hp with 110-volt motors, which extend out the back of the saw (as shown *above*) and drive the blade with one belt. Because the hanging motor adds 15–20" of depth to the saw, it limits the use of outfeed stands or tables and prevents you from stowing the saw flat against a wall.

With a contractor saw, you get 30" to 36" of rip capacity standard (with 50"-capacity rails optional on some models), smaller handwheels, and much lighter weight (200–350 lbs). These saws tend to vibrate more than cabinet-style saws, suffer greater likelihood of drive-belt slips (because only the weight of the motor provides tension), and generate higher noise levels. Many models include dust hoods for connection to a dust collector, and some even include a plastic shroud around the blade to channel dust.

Although its components are lighter-duty than those of cabinet saws, you still can set up a contractor-style saw for pinpoint precision. However, you might have to compensate for the reduced

SMALLER PARTS=MORE WORK



The small forged-steel trunnions on this saw secure to the top rather than the base, making top-to-blade alignments trickier.

power with slower feed rates and thinner kerf blades. Cuts in thick, hard stock may prove difficult or impossible.

A bare-bones contractor saw costs about \$400, or as much as \$800 with added features. Deluxe models overlap the price range of hybrid tablesaws—and even approach some low-cost cabinet saws—so compare before buying.

Pros:

- Prices range from \$400 to \$800
- Rip capacity equals cabinet-style saws on some models
- Dust hoods or shrouds on some models
- Lighter weight than cabinet saws
- Accurate when set up correctly
- A few models have built-in mobile bases

Cons:

- Limited power means struggles in thick, hard materials
- Trunnions mount to top rather than base, making adjustments difficult and shorter-lasting
- Lighter-duty components allow more vibration
- Open design reduces dust-collection efficiency and increases noise
- Motor hangs out the back of the stand, adding to footprint



Hybrids blend big-saw features at 110 volts

A hybrid tablesaw marries the small-shop needs of a contractor-style saw (110-volt electricity, light weight) with some of a cabinet saw's benefits (cast-iron guts, enclosed base for good dust collection and noise reduction) in a modest price range. The features vary from one saw to another. For example, some models have forged-steel trunnions as on a contractor saw, and others

CAST TRUNNIONS ARE RARE

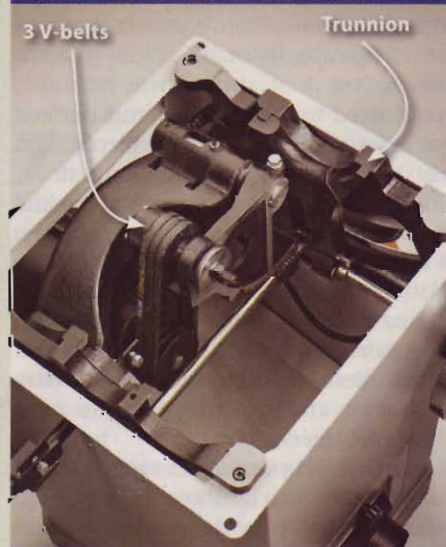

The trunnions on this Steel City saw, as well as on Craftsman's hybrid, mount to the cabinet rather than the top.



have cast-iron trunnions, though they're smaller than those on a cabinet saw.

To enclose the cabinet, manufacturers mount the motors below the arbor assembly, as with cabinet saws, but these 1½- to 2-hp motors won't have the muscle of a cabinet-style saw. Like a contractor-style saw, most have trunnions that mount to the top rather than the cabinet, making top-to-blade adjustments even more difficult (thanks to the enclosed base) and increasing vibration slightly. See the photo *opposite* for a welcome exception to this style.

Hybrids come standard with 30"-rip capacity fence rails, but you can upgrade to longer rails for up to 54" capacity. The fences typically are the same heavy-duty models sold with cabinet saws.

Pros:

- Prices range from \$700 to \$1,100
- Up to 54" rip capacity on some models (with optional fence rails)
- Enclosed cabinet aids dust control and reduces noise
- Heavier weight than contractor saws
- Motors run on 110-volt electricity
- Some models have cabinet-mounted trunnions

Cons:

- Most models have top-mounted trunnions, making blade/table alignment more difficult
- Power (1½ to 2 hp) similar to contractor-style saws



Benchtop saws: Good options for small shops

You don't have to be a contractor or trim carpenter to appreciate these portable tablesaws. In spite of their small stature and light weight, you can cut hardwoods if you slow your feed rate and use a thin-kerf blade, but some struggle in 2"-thick hardwoods.

Benchtop/job-site saws feature 110-volt universal motors that provide respectable power but are loud and prone to vibration, thanks in part to direct- or gear-drive power trains. Models with closed bases feature good dust collection, but the smaller ports are sized for shop vacuums. Many benchtop saws have shallow miter slots that accept only light-duty miter gauges. They also can be unsafe when cutting large workpieces by yourself because of the narrow footprint and small tabletop. Rip capac-

ity tops out at 25" on the better saws in this class, with some as little as 12". Because of the small tops, you'll need infeed and outfeed support for boards more than 4' long, as well as support for crosscutting stock of that length. The better-equipped benchtop/job-site saws carry price tags that rival those of middle-of-the-pack contractor saws. 🌲

Written by **Bob Hunter**

Pros:

- Prices range from \$150 to \$700
- Lightweight and easily portable, especially with collapsible, wheeled stands
- Motors run on 110-volt electricity
- Up to 25" rip capacity on some models
- Decent dust collection on closed-base models
- Small footprint

Cons:

- Noisy universal motors tend to lack the power of full-size tablesaws
- Increased vibration leads to less-than-furniture-quality cuts.
- Aluminum or molded plastic tabletops lack the durability and vibration dampening of cast iron
- Some models cannot accept a full ¾" stacked dado set on their arbors
- Blade-height adjustments typically made with a single, small, uncomfortable handwheel
- Most models don't have geared-bevel adjustments and must be done manually, making them tougher to set accurately
- Higher-priced saws overlap mid-priced contractor-style saws
- Light-duty fences
- Thin throat insert plates make it difficult or impossible to make your own zero-clearance inserts

BIG PUNCH IN A SMALL PACKAGE

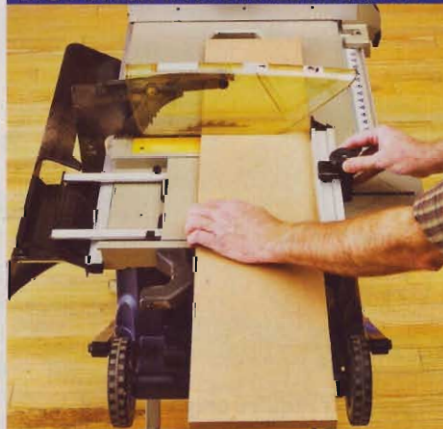

Ryobi's job-site saw features a sliding crosscut table that locks into place when you want to make a rip cut or for storage.

ONLY BASIC SKILLS REQUIRED

Bench with Storage

In just a weekend and using only a few power tools, build this screw-and-glue-joined chest to hold rain gear, blankets, or other items.

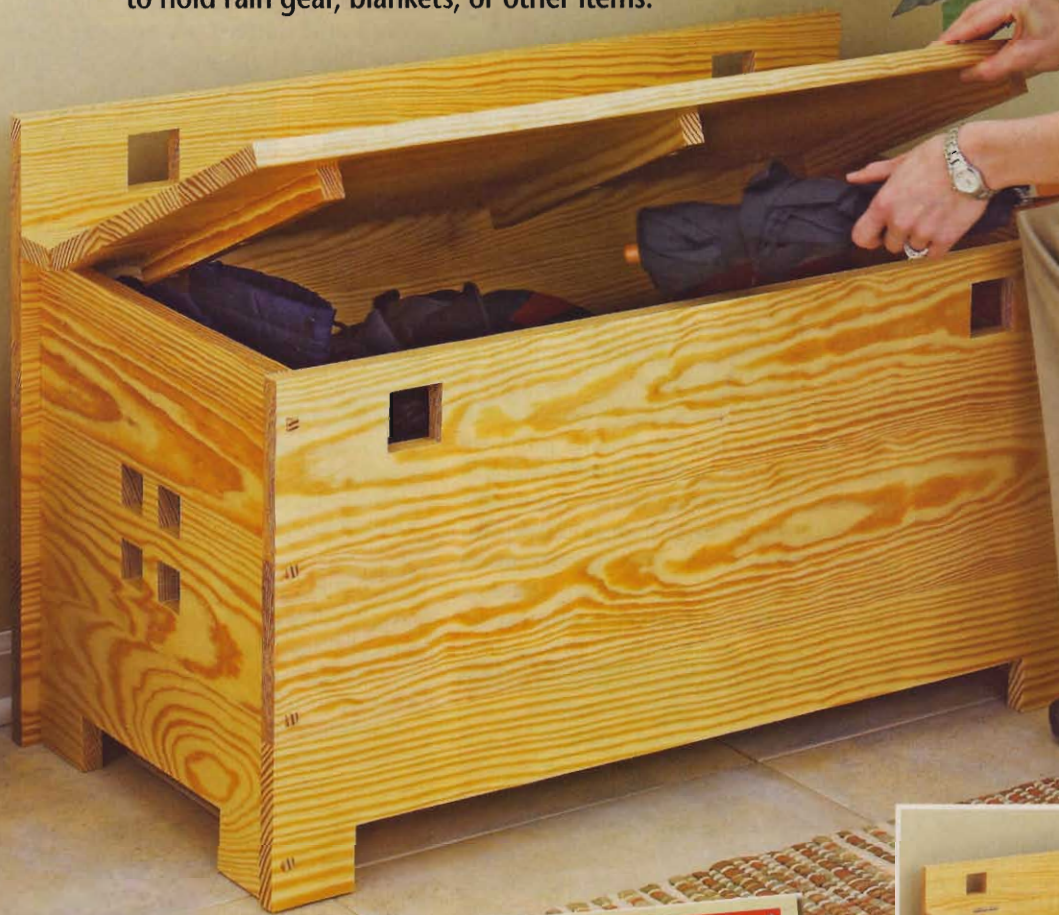

BASIC-BUILT™
GREAT PROJECTS. SIMPLE TOOLS.

Basic-Built projects require only a limited number of inexpensive and readily available tools and materials. For more information, go to woodmagazine.com/basicbuilt.



PROJECT HIGHLIGHTS

- Overall dimensions: 34½" wide × 17¾" deep × 22" high.
- Material needed: ¾" pine.
- Power tools needed: a portable circular saw, drill, jigsaw, random-orbit sander, and benchtop tablesaw (you can skip the tablesaw if you opt for round button plugs)

Skill Builder

- Learn how to conceal mounting screws with decorative square plugs.

Start with the panels

1 From edge-glued ¾"-thick pine (we used Southern yellow), cut two 19×34½" panels—one for the sides (A) and the other for the front (B)—and a 23×36" panel for the back (C).

2 Smooth any uneven joints along the panel surfaces using a random-orbit sander. Then, using a circular saw or a tablesaw, cut the sides, front, and back to the finished sizes [Materials List, page 69], cutting two sides from one of the 19×34½" panels. To make cuts with your circular saw that rival tablesaw precision, see the **Shop Tip**, above.

3 Lay out the cutouts at the bottoms of the sides (A), front (B), and back (C), and the 1½"- and

SHOP TIP

Yes, you can get clean, straight cuts with portable power tools

Been frustrated by poor-quality cuts using your portable power tools? Following these pointers will ensure wander-free machining and reduced tear-out.

- Clamp a straightedge to the workpiece as a guide for the tool. You don't need a fancy guide—the factory-cut edge of a piece of MDF or melamine panel works great, as shown *below*.
- Use sharp, clean blades and bits.
- Clamp a backer to the workpiece on the appropriate face to avoid chip-out.
- Use a slow feed rate, but be careful not to go too slowly or you'll burn the wood.



MDF straightedge guide

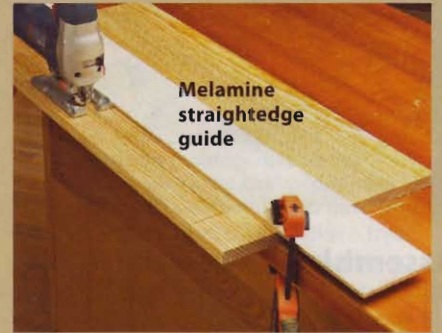

Melamine straightedge guide

2"-square openings in the parts [Drawings 1 and 2]. Jigsaw the bottom cutouts to shape. Next, drill two ½" blade-start holes through the marked square openings, and jigsaw out the squares [Photo A].

To ensure square cuts, use a high-quality blade with 10 teeth per inch.

JIGSAW THE SQUARE OPENINGS

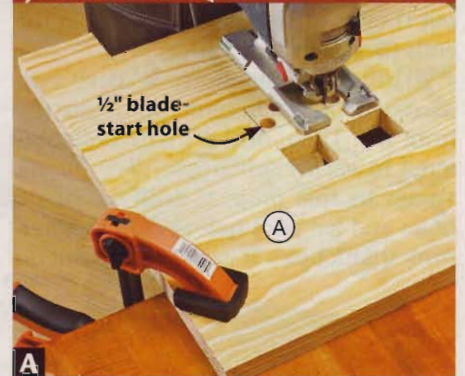

With the marked square openings in the sides (A), front (B), and back (C) overhanging your workbench, jigsaw out the openings.

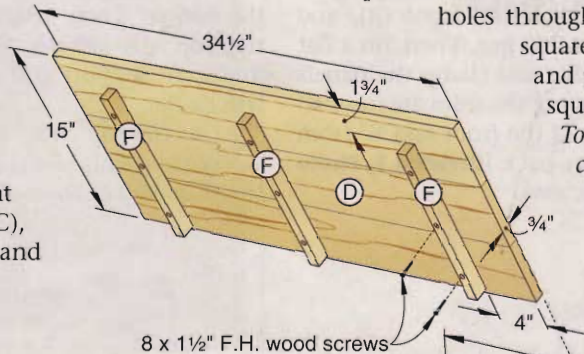

1 EXPLODED VIEW

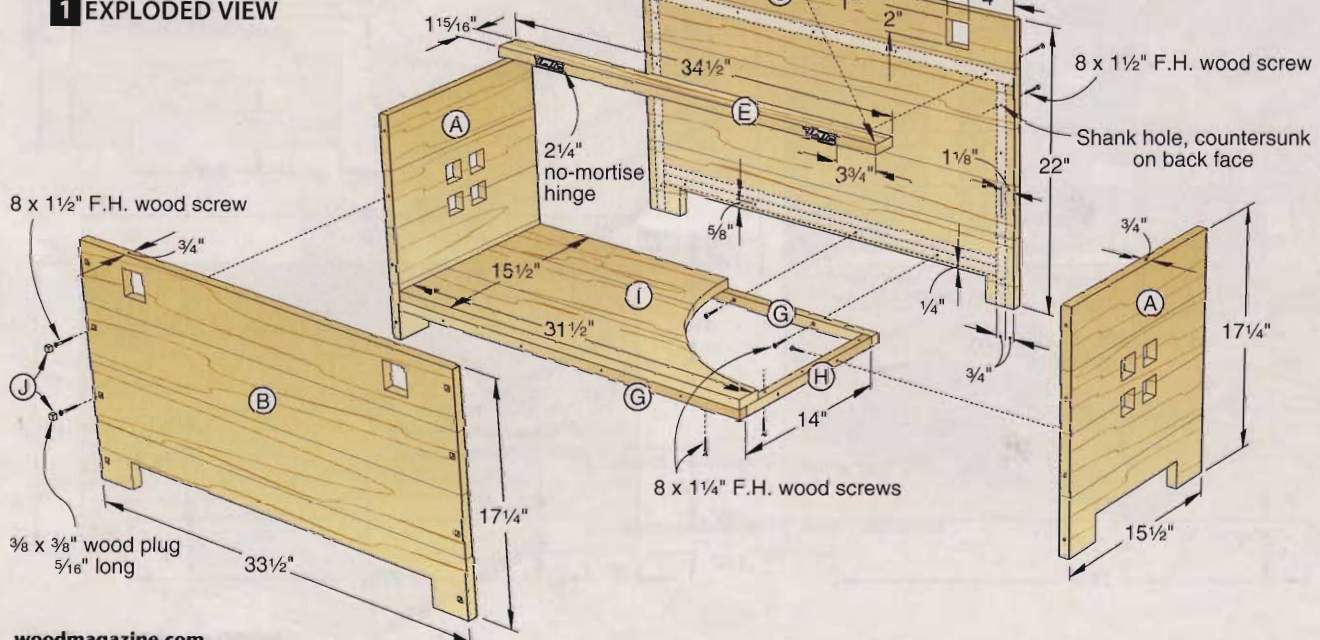

CHECK THE ASSEMBLY FOR SQUARE

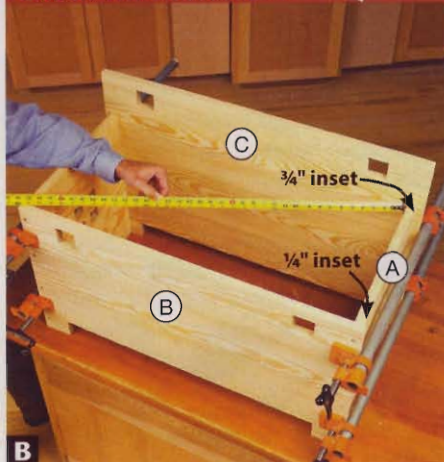

Measure for equal diagonals to ensure a square assembly. Also, verify the insets of the ends (A) from the front (B) and back (C).

INSTALL THE NO-MORTISE HINGES IN TWO EASY STEPS

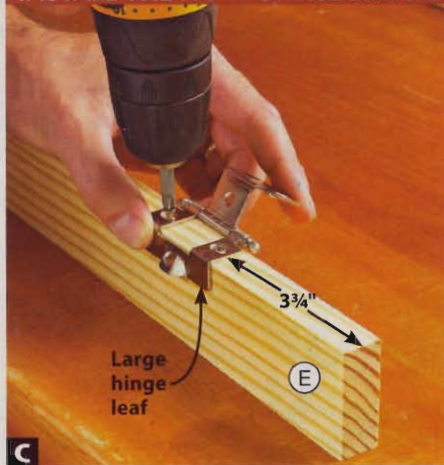

Screw-mount the large leaves of the 2 1/4" no-mortise hinges to the edge of the top support (E), 3 3/4" from the ends.

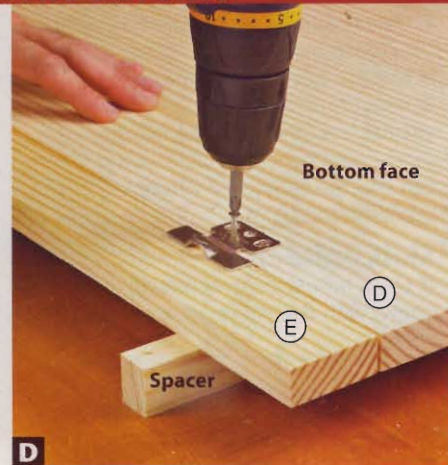

With the top (D) and top support (E) bottom face up and the ends aligned, screw-mount the small hinge leaves to the top.

Assemble the bench

1 Mark centerpoints for the four screw holes at each end of the front (B) and back (C) [Drawings 1 and 2]. Note that the dimensions for the back are the same as those shown for the front, as measured from the bottom [Drawing 2], but they're offset 1 1/8" (not 5/8") from the ends [Drawings 1 and 2].

2 Drill 3/8" counterbores 1/4" deep centered on each centerpoint on the front (B). Then, drill a shank hole centered in each counterbore. (For the #8 screws in this project, drill 5/32" shank holes and 7/64" pilot holes.) Drill countersunk shank holes at each centerpoint on

the back (C). To conceal the screw holes on the front with square mortise plugs (J), lay out the 3/8 x 3/8" mortises centered around the shank holes on the front. Now, form the 1/4"-deep mortises using a sharp 3/8" chisel. If you don't have a tablesaw, as an alternative, you can drill 3/8" counterbores 1/4" deep centered on the shank holes and use button plugs.

3 Sand the sides (A), front (B), and back (C) to 220 grit. Then, on a flat surface, assemble and clamp the panels together, verifying the sides are inset 1/4" from the ends of the front and 3/4" from the ends of the back [Drawing 1, Photo B]. Drive the screws.

Add the top and bottom

1 From edge-glued stock, cut a 16 x 36" panel for the top (D). Then, crosscut and rip the panel to the finished size of 15 x 34 1/2". Now, cut the top support (E) to the size listed. Sand the parts smooth.

2 Mount the 2 1/4" no-mortise hinges to the top support (E) [Drawing 1, Photo C], using the screws supplied with the hinges. Then attach the hinges to the top (D) [Photo D]. Place spacers under the support and top so the hinge will lie flat.

3 Cut the top cleats (F) to size. Mark centerpoints for the countersunk shank holes on the bottom face of the

2 PARTS VIEW

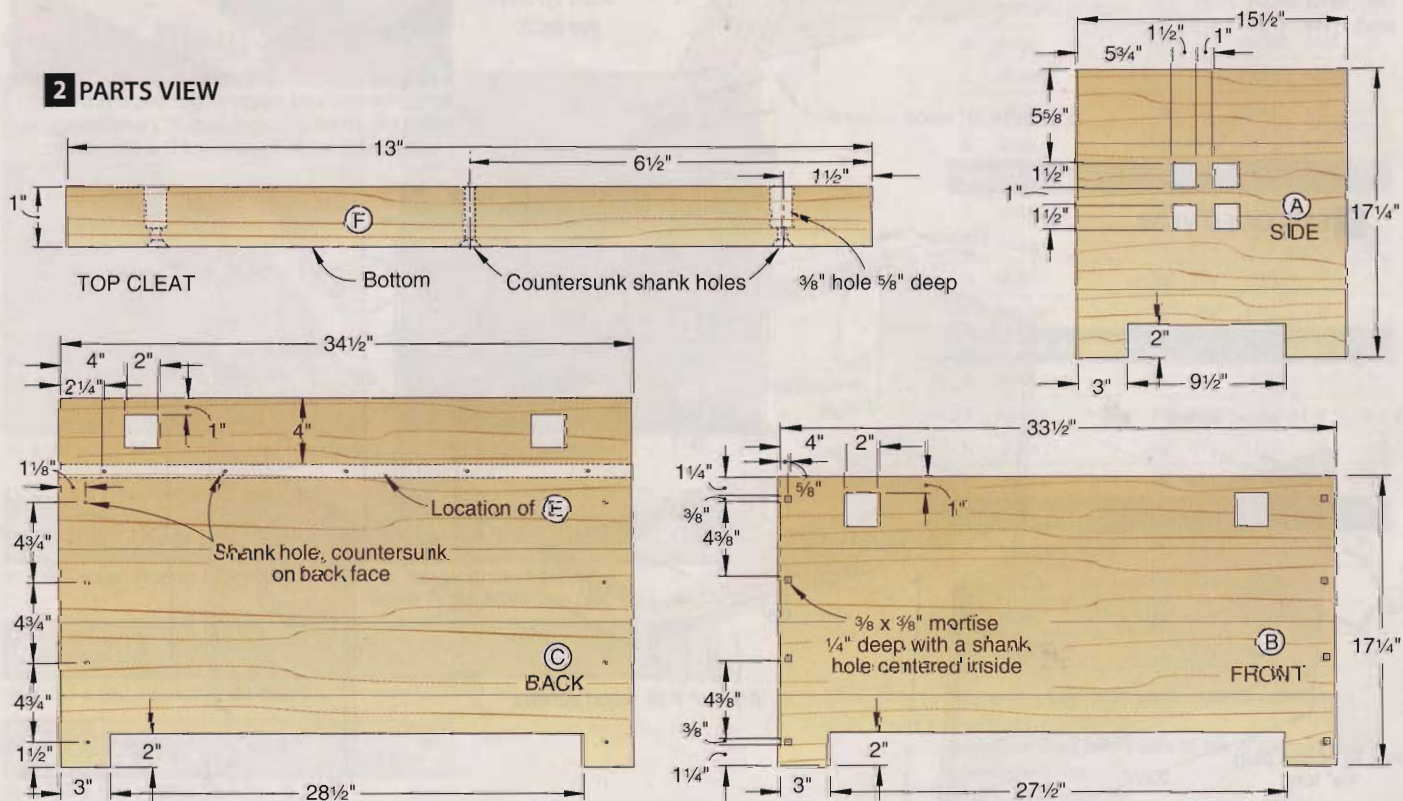

MOUNT THE TOP CLEATS

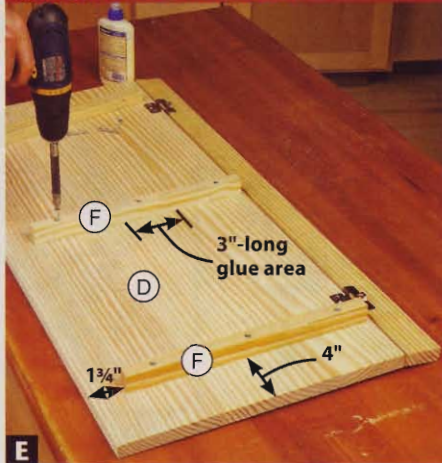

E Glue and screw the top cleats (F) to the top (D). Apply glue to only a center 3"-long area on the cleat to allow for top movement.

cleats [Drawing 2]. Drill the holes. Then, using the shank holes on the top face of the cleats as guides, drill the $\frac{3}{8}$ " holes $\frac{5}{8}$ " deep to provide clearance for the screws to accommodate movement of the top (D).

4 Sand the top cleats (F) smooth. Then, glue and screw them to the bottom face of the top (D) [Drawing 1, Photo E].

5 Glue the top/top support assembly (D/E/F) in position on the bench, centered side-to-side with the support tight against the back (C). Apply glue to the back edge of the support and the areas on the bottom face of the support

TRIM THE MORTISE PLUGS

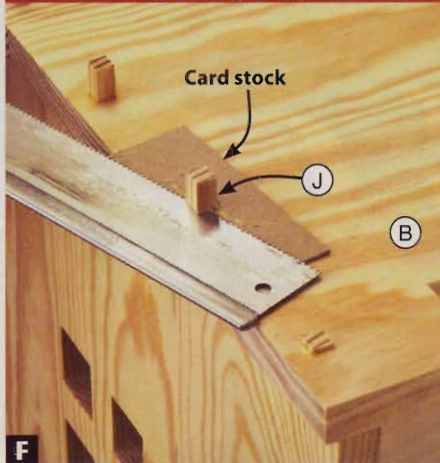

F Place a piece of approximately $\frac{1}{16}$ "-thick card stock with a hole in it over each plug blank. Trim the plugs using a fine-tooth saw.

that contact the sides (A). Then, drill the countersunk shank holes through the back and into the support [Drawing 1], and drive the screws.

6 Cut the bottom front/back and side cleats (G, H) to the sizes listed to fit inside the bench. Drill the countersunk shank holes through the cleats for attaching them to the bench and for mounting the bottom (I) [Drawing 1]. Then, glue and screw the cleats in position, where dimensioned.

7 From edge-glued stock, cut a $16\frac{1}{2} \times 32\frac{1}{2}$ " panel for the bottom (I). Measure the inside of the bench. Then, crosscut and rip the panel to your mea-

surements. Sand smooth. Now, glue and screw the bottom in place.

Finish up

1 To form the mortise plugs (J), cut a $\frac{3}{8} \times \frac{3}{8} \times 18$ " blank using a tablesaw. Crosscut eight 1"-long pieces from the blank. Glue a piece into each mortise in the front (B). Then, trim the plugs approximately $\frac{1}{16}$ " proud of the front [Photo F]. Now, using a 150-grit sanding block, slightly round the plugs, leaving them proud.

2 Finish-sand any areas that need it to 220 grit. Apply three coats of a clear finish. (We used a water-based polyurethane, sanding to 220-grit between coats.) Now, place the bench where desired and fill 'er up. 🌲

Written by **Owen Duvall**

Project design: **Kevin Boyle**

Illustrations: **Roxanne LeMoine; Lorna Johnson**

Materials List

Part	FINISHED SIZE			Matl.	Qty.
	T	W	L		
A* sides	$\frac{3}{4}$ "	17 $\frac{1}{4}$ "	15 $\frac{1}{2}$ "	EP	2
B* front	$\frac{3}{4}$ "	17 $\frac{1}{4}$ "	33 $\frac{1}{2}$ "	EP	1
C* back	$\frac{3}{4}$ "	22"	34 $\frac{1}{2}$ "	EP	1
D* top	$\frac{3}{4}$ "	15"	34 $\frac{1}{2}$ "	EP	1
E top support	$\frac{3}{4}$ "	1 $\frac{15}{16}$ "	34 $\frac{1}{2}$ "	P	1
F top cleats	$\frac{3}{4}$ "	1"	13"	P	3
G bottom front/back cleats	$\frac{3}{4}$ "	$\frac{3}{4}$ "	31 $\frac{1}{2}$ "	P	2
H bottom side cleats	$\frac{3}{4}$ "	$\frac{3}{4}$ "	14"	P	2
I* bottom	$\frac{3}{4}$ "	15 $\frac{1}{2}$ "	31 $\frac{1}{2}$ "	EP	1
J* mortise plugs	$\frac{3}{8}$ "	$\frac{3}{8}$ "	$\frac{5}{16}$ "	P	8

*Parts initially cut oversize. See the instructions.

Materials key: EP—edge-glued pine, P—pine.

Supplies: #8 \times 1 $\frac{1}{4}$ " and #8 \times 1 $\frac{1}{2}$ " flathead wood screws; 2 $\frac{1}{4}$ " no-mortise hinges (2).

Blade and bit: High-quality jigsaw blade with 10 teeth per inch.

Cutting Diagram

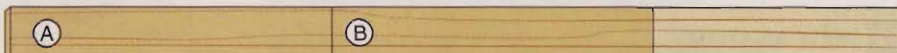

$\frac{3}{4} \times 5\frac{1}{2} \times 96$ " Southern yellow pine (1x6) (4 needed)



$\frac{3}{4} \times 5\frac{1}{2} \times 96$ " Southern yellow pine (1x6) (2 needed)



$\frac{3}{4} \times 5\frac{1}{2} \times 96$ " Southern yellow pine (1x6)

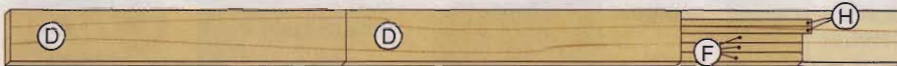

$\frac{3}{4} \times 5\frac{1}{2} \times 96$ " Southern yellow pine (1x6)



$\frac{3}{4} \times 5\frac{1}{2} \times 96$ " Southern yellow pine (1x6) (2 needed)



$\frac{3}{4} \times 5\frac{1}{2} \times 36$ " Southern yellow pine (1x6)

*Rip a $\frac{3}{8}$ "-square blank as explained in the instructions.



Learn to love your Skew Chisel



Watch a FREE video on using a skew chisel at woodmagazine.com/skew

Interested in spindle turning? Then come along and discover the keys to effectively sharpening and using the indispensable skew chisel. You'll soon be producing fine, ribbonlike shavings and superbly smooth surfaces in need of little sanding.

Which skew is best?

You'll find skew chisels with different cross sections—round, oval, and rectangular—and widths from ¼" to 1½", but they all operate the same way. The tool bevel [Drawing 1] rides against the wood as the angled cutting edge peels away shavings. We'll concentrate on the rectangular skew because it's the most common, versatile, and easiest to sharpen. And, as we'll explain later, choose the widest skew you can afford.

The square corners on the shank of a regular rectangular skew [Drawing 2] don't roll easily on the tool rest and

1 SKEW ANATOMY

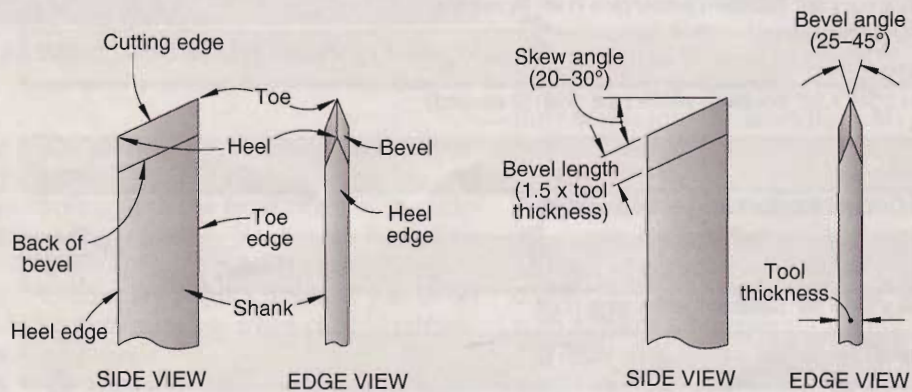

make it difficult to smoothly slide the tool along it. When buying a rectangular skew, avoid these shortcomings by

purchasing a "rolled-edge" model. If you already have a square-cornered skew, round the edges on your grinder.

SUPERIOR CUTS COME FROM SHARP SKEWS

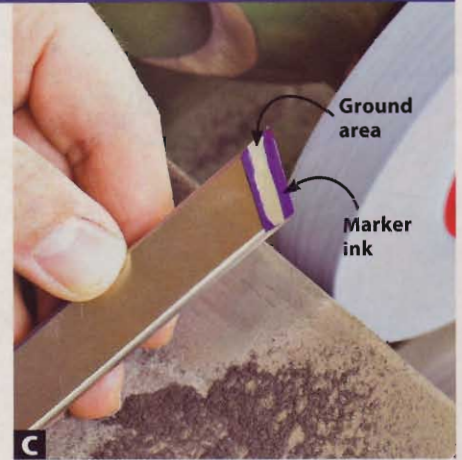

Choose your skew angles

The term “skew” refers to the angle of the cutting edge. For the three uses of a skew chisel—planing cuts, V-cuts, and forming beads—a 20–30° skew angle works best [Drawing 1].

Bevel angles vary from 25° to 45° [Drawing 1]. A 25° bevel angle slices easily through the wood but gives you a fragile edge that needs frequent sharpening. A 45° bevel holds up well in tough stock but won't cut as easily. A good rule of thumb is to make the bevel length about 1½ times the tool thickness (¾" for a ¼"-thick tool).

Grind the point to shape

When sharpening lathe tools with a 1,725-rpm bench grinder equipped with a 50–80 grit aluminum oxide wheel. The combination of a coarse wheel and slow speed gives you greater control of the sharpening process.

To grind the skew angle, lay the tool flat on the grinder tool rest, and adjust the rest so the tool shank is perpendicular to the face of the grinding wheel. Grind slowly to minimize heat buildup, and periodically check your progress with a protractor or angle guide.

Now you're ready to grind the bevel. Mark the bevel length on both sides of

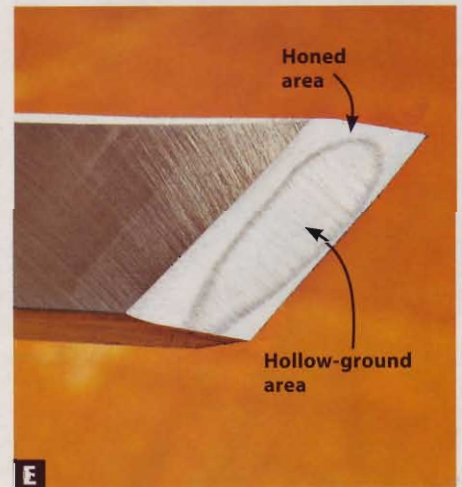
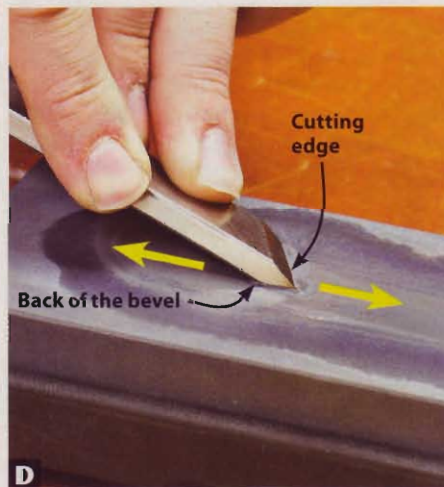

the tool with a fine-point permanent marker [Photo A]. Rest your hand on the grinder tool rest and the tool on your hand. Adjust the grinding angle by raising or lowering the tool handle. Keeping the cutting edge parallel to the face of the grinding wheel, move your hand and the tool side-to-side along the tool rest [Photo B]. To clearly see where you are grinding, color the developing bevel with a permanent felt-tip marker [Photo C]. Turn the tool over often to check your progress. Keep the bevels on both sides uniform and the cutting edge centered in the tool thickness.

Honing the ultimate edge

You can use a skew right off the grinder, but a honed skew cuts easier and leaves a smoother surface than one sharpened only on the grinder. Begin honing with a 320-grit bench stone. Wet the stone with the proper lubricant. Place the back of the bevel on the stone, and then raise the handle until the cutting edge makes contact [Photo D]. Press down on the bevel and slide the tool back and forth. The grinding wheel forms a concave surface on each bevel, so only the back and cutting edge contact the stone, minimizing the amount of steel removed [Drawing 3]. As you hone, check often to make sure the back and cutting edge of the bevel contact the stone equally.hone both bevels until the edges are flat, leaving an oval hollow [Photo E].

Switch to a 1,000-grit stone and polish the flat edges. When the tool dulls, quickly restore the edge by honing only with the 1,000-grit stone. As you rehone the tool, the hollow oval gradually disappears. When it becomes faint, return to the grinder, reestablish the hollow grind on each bevel, and then hone again with both stones.

2 SKEW CROSS SECTIONS

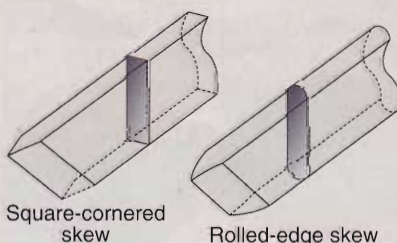

3 HONING

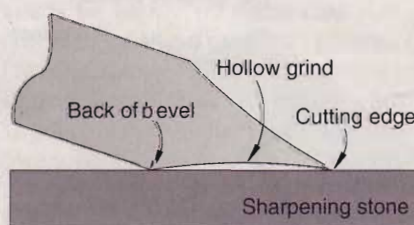

THREE STARRING ROLES FOR THE SKEW

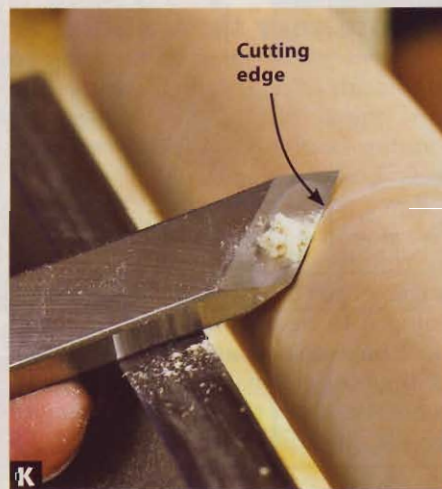
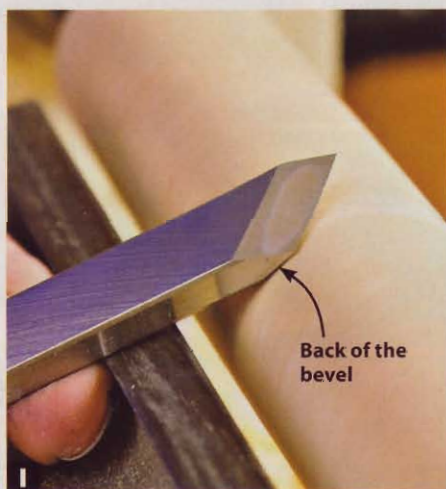
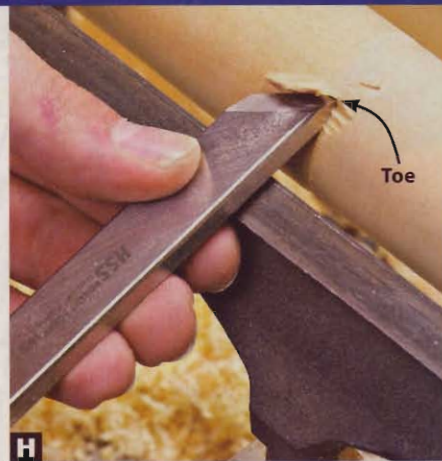
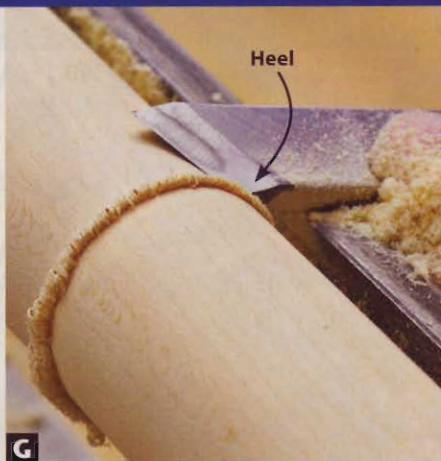
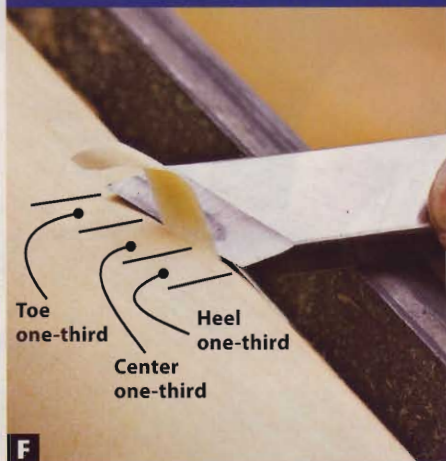

Planing cuts

Planing cuts are made with the center one-third of the cutting edge [Photo F]. Cutting too close to the heel risks digging into the workpiece and rapidly removing too much material [Photo G]. Cutting too close to the toe risks catching the point and tearing off chunks of material [Photo H]. A wide skew is easier to use than a narrow one simply because the center one-third of a wide skew is wider than that of a narrow one.

To get the feel of a planing cut, first use your spindle-roughing gouge to form

a turning square into a cylinder. With the lathe stopped, position the tool rest slightly above center and about 1/2" away from and parallel to the surface of the workpiece. With the lathe running, hold the tool handle below the tool rest, place the side of the skew on the tool rest, and the back of the bevel against the wood [Photo I]. Orient the cutting edge 45° to the workpiece axis [Photo J]. (Regardless of the skew angle, the cutting edge *always* forms a 45° angle with the axis of the workpiece.) Raise the tool handle slightly while pulling back on the tool

until the center of the cutting edge also touches the wood [Photo K]. With the tool on the tool rest, and the back and cutting edge of the bevel contacting the wood, slowly push the tool along the length of the workpiece, peeling off shavings using the center one-third of the cutting edge. If the cut wanders toward the heel, slightly tip the tool on the tool rest toward the toe edge. If the cut wanders toward the toe, slightly tip the tool toward the heel edge. Practice planing in one direction, flip the tool, and practice in the other direction.

V-cuts

These cuts form stand-alone decorative elements and also serve as the starting point for forming beads. Begin a V-cut by positioning the tool rest slightly below center and about 1/2" away from and parallel to the workpiece surface. Stand the tool vertically with the toe edge on the rest [Drawing 4], holding the handle low and the tool 90° to the workpiece [Photo L]. Place the toe of the skew close to the surface at the 10:30 position. Now slowly raise the tool handle, pivoting the tool on the rest, and lower the

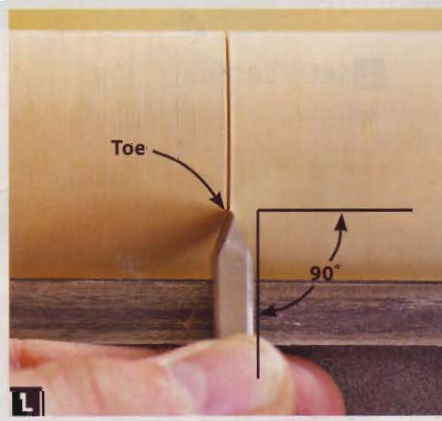
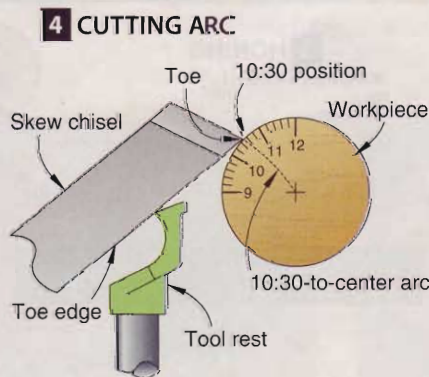



toe into the workpiece [Photo M]. Make a shallow cut following a 10:30-to-center arc. Do not push the tool into the workpiece; only raise the handle.

Now pivot the tool handle to the left, and place the toe slightly to the left of the center cut. Raise the handle to lower

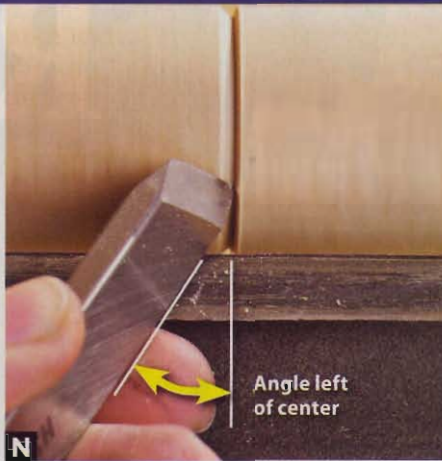

the toe into the workpiece, and cut to the bottom of the center cut [Photo N]. Pivot the tool to the right, and repeat [Photo O]. To widen the V-cut, increase the angle of the tool to the left and right, and cut from the 10:30 position to the bottom of the center cut. To increase the

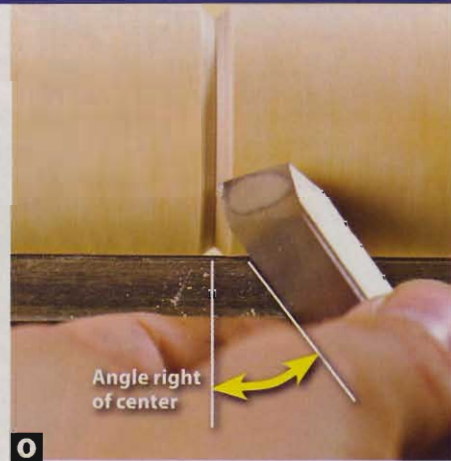

depth of the V-cut, decrease the angle of tool to the left and right, place the toe at the edge of the V-cut, and make additional cuts. Follow the 10:30-to-center arc with the toe, raising the tool handle more with each cut. Never raise the handle above the tool rest.

Beads

Lay out the centerline and edges of the bead on the workpiece with a pencil [Photo P]. Position the tool rest slightly below center. Then define the width of the bead, and remove waste material by making V-cuts to the bead depth at both marked edges.

To form the left half of the bead, lay the skew flat on the tool rest at a 90° angle to the workpiece, with the cutting edge pointing left. Rest the back of the bevel against the wood, with the heel of the cutting edge close to the right edge of the V-groove. Engage the heel by slowly raising the tool handle and gently pulling it back. As the skew begins to cut, continue to raise the handle, and roll the tool onto the heel edge, forming a small radius [Photo Q]. The heel of the cutting edge should start cutting at the 10:30 position and cut toward the center of the workpiece.

Repeat this process, increasing the bead radius in small increments until a smooth curve extends from the centerline to the bottom of the left-hand V-cut [Photo R]. Always start your cuts with the tool flat on the tool rest, and finish with the tool standing vertically on the heel edge [Photo S]. Cut with the heel of the tool, and do not raise the tool handle above the tool rest. Do not cut away the centerline. You'll need it as a reference to keep the bead symmetrical, and you can sand it off when the bead is complete. Flip the skew over and form the right half of the bead.

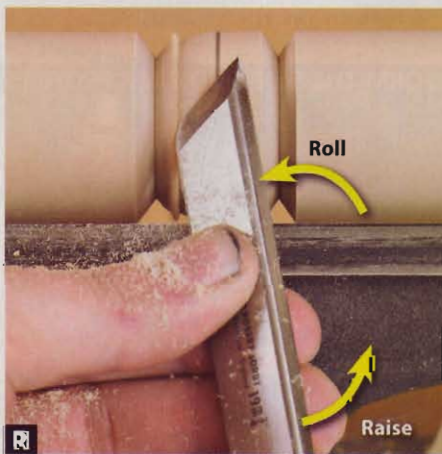
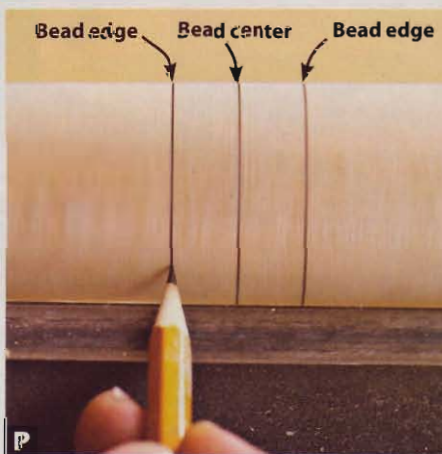

Practice, practice, practice
Master the skew chisel by practicing on scrap rather than on a turning you want to keep. Ruining a candlestick or lamp base causes permanent skew-shyness. Instead, rip 2x4s into 2x2s and cut them

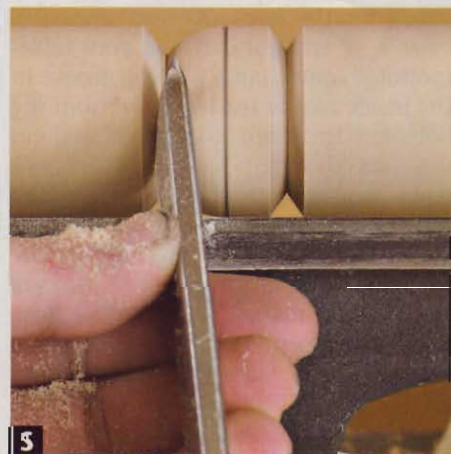
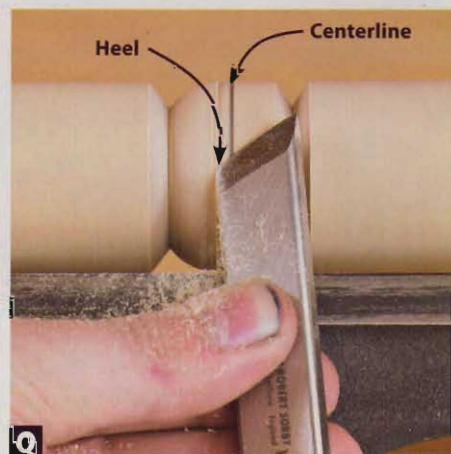

6–12" long, avoiding knots. Practice planing cuts first. When you are comfortable with planing, make a series of evenly spaced V-cuts. Then turn the V-cuts into beads. 🌲

Written by **Jan Svec** with **Brian Simmons**

Remote Control Corral

Round up all your wandering remotes and keep them close at hand with this tabletop organizer.

Make the parts

1 For all the parts, plane a $\frac{3}{4} \times 8\frac{3}{4} \times 32$ " board to $\frac{1}{2}$ " thick. (You can edge-join narrow stock to achieve the $8\frac{3}{4}$ " width.) From this stock, cut an 18"-long blank for the back (A) and sides (B). With a $\frac{1}{2}$ " straight cutter in your table-mounted router, cut a $\frac{1}{4}$ "-deep groove in the inside face of the blank, $\frac{3}{4}$ " from the bottom edge. Then from the blank, cut the back to length [Materials List, next page], and set it aside. Next rip the remaining blank to 8" wide, and cut the two sides to length. Now readjust the router-table fence, and rout $\frac{1}{2}$ " rabbets along the inside rear edges of the sides [Exploded View].

2 Adhere the sides (B), inside face to inside face, with double-faced tape. Then adhere the sides to the inside face of the back (A), flush at the bottom and centered side-to-side. Next photocopy the Side Pattern on the WOOD Patterns® insert and adhere it to the top side with spray adhesive. Now bandsaw the bottom cutout in all three parts [Photo A], and drum-sand the cutouts to the line.

3 Separate the sides (B) from the back (A). Bandsaw the upper profile in both sides [Photo B], and drum-sand to the line.

4 Photocopy the Back Upper Profile Pattern on the pattern insert, and

adhere it to the back (A). Bandsaw and sand the profile to shape.

5 From the $\frac{1}{2}$ " stock, cut the bottom (C) to size. Rout grooves for the dividers (D,E), and sand radii on the front corners [Exploded View].

FORM THE SIDE AND BACK PROFILES

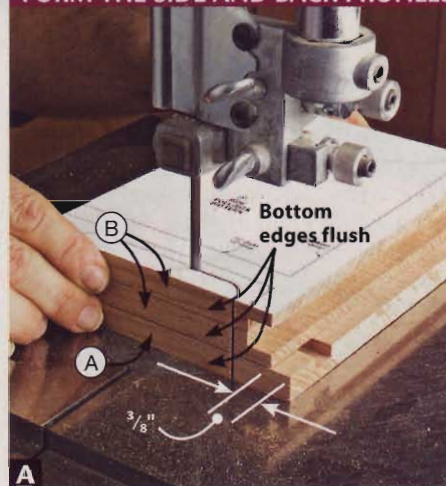

A Adhere the sides (B) to each other and the back (A) with double-faced tape and stack-cut the bottom cutouts.

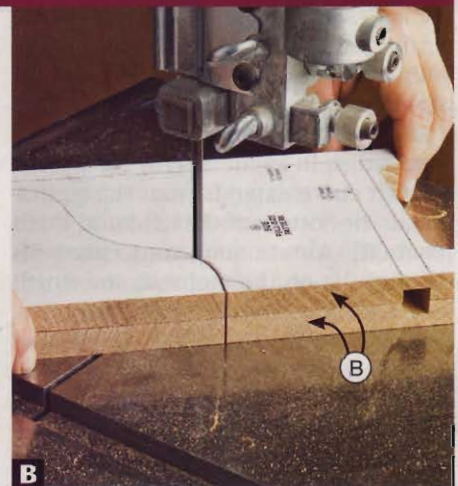

B With the bottom cutouts finish-sanded, separate the sides (B) from the back (A), and stack-cut the upper profile in both sides.



Why Outdoor Finishes Fail

(And How to Prevent It)

Left to the elements, bare wood quickly falls prey to everything under—and including—the sun. To ward off the brutal elements, we apply finishes and other protections to our outdoor projects.

Thing is, once we store our brushes and sprayers, too often we forget that these finishes require periodic maintenance. As seasons pass, the paint on the garden arbor cracks and peels, the patio furniture splits and spalls, and colonies

of mold form a forest of black dots on decks and planters. If you've witnessed these signs, you may wonder why these outdoor finishes failed. We'll tell you, and provide a prevention and fix-it program to boot.

Outdoor Finish Selector and Schedule

FINISH TYPE		APPLICATION METHOD (1)	REAPPLICATION FREQUENCY (2)		DURABILITY (3)	NEED PRIMER?	NO. OF COATS (4)	WELL-SUITED FOR (5)	ADDITIVES/COMMENTS (6)
			H	V					
PENETRATING	WATER SEAL/REPELLENT/PROTECTANT	GS	6-12 MO.	3 YR.	P	NO	1-2	D	WP in the water seal products; M, UV, WP in water repellent/protectant products. Water seals let wood gray; repellent/protectant products help keep wood's natural color if frequently applied.
	PENETRATING OIL	B,S,W	1 YR.	2-3 YRS.	P	NO	1-2	D,L,S	Soaks into grain to keep wood from drying out. If it contains linseed (vegetable) oil, will serve as food for mildew colonies. Requires occasional cleaning with a water/bleach solution to stem mold/mildew growth.
	SEMITRANSSPARENT OIL STAIN	B,W	3-5 YRS.	3-8 YRS.	F	NO	1	D,L	M, UV, WP; adds some color while still allowing wood grain to show. If the previous finish was water-based, strip surfaces before reapplication. With oil-based stains, apply after thorough cleaning.
FILM-FORMING	MARINE SPAR VARNISH	B,S	1½ YRS.	2-3 YRS.	F	NO	3-4	B	UV, WP; offers excellent gloss retention, though it can yellow with time and multiple coats. Boatbuilders swear by it, but often strip and reapply spar varnish every year. Reapply with at least two coats.
	POLYURETHANE WITH UV INHIBITORS	B	2 YRS.	2-3 YRS.	G	NO	2-3	S	UV, WP; offers good gloss retention. To penetrate end grain during first coat, thin polyurethane with 25% solvent. Like spar varnish, this finish may yellow over time.
	SOLID-COLOR WOOD STAIN	B,S	3-5 YRS.	5-15 YRS.	G	YES	2-3	L	M, UV, WP; excellent ultraviolet protection, but not durable for high-traffic areas. Protects wood surface while enhancing wood texture. Stain-blocking primer needed on tannin woods, such as redwood and cedar.
	OIL*/LATEX EXTERIOR PAINT	B, R, S	3-5 YRS.	7-15 YRS.	G	YES	2	D,L,S	M, UV, WP; disguises wood with color, reducing texture. Excellent ultraviolet protection and wear. Use enamel for outdoor projects—furniture and garden structures—to avoid chalking issues.

* Many states have banned oil-based paints for environmental reasons; all states may ban oil-based paints over the next three years.

1. (B) Brush
(GS) Garden sprayer
(R) Roller
(S) Sprayer
(W) Wipe on

2. (H) Horizontal surfaces
(V) Vertical surfaces
Note that exposure to direct sunlight and excessively rainy climate shortens finish life.

3. For surfaces that receive a lot of abuse, such as a deck:
■ G Good
■ F Fair
■ P Poor

4. For bare wood; otherwise, one coat.

5. (B) Boats, and other applications where wood flexes
(D) Decks
(L) Large structures, furniture
(S) Small projects

6. (M) Mildewcide
(UV) Ultraviolet inhibitors
(WP) Waterproof
Insect protection, such as an insecticide, can be an additive you mix in with the paint or stain for protection against crawling or flying insects.

Brush up on finish choices

Outdoor wood finishes fall into two groups: penetrating and film-forming. (See the chart above.) As the name suggests, penetrating finishes soak into the wood's fibers. Many contain water repel-

lents and preservatives that work to prevent mold and mildew and ward off invasions by insects.

Film-forming finishes, which include paints, solid-color stains, and varnishes, lie on top of wood surfaces. These shed

water while providing various degrees of protection from the sun. Pigmented films best shield wood from the elements. Through wear and abuse, though, all outdoor finishes weaken over time, regardless of their properties.

A dirty rotten shame: Meet wood's enemies

So what happens when a piece of finished wood sits outside? It gets beaten up, as if struck by the ol' one-two punch. The first blow is a pounding by the sun's ultraviolet (UV) rays, causing the protective finish to degrade. Film finishes may crack and peel open, as shown at right. With clear finishes, the sun's rays attack the lignin that holds wood fibers together, causing them to loosen and flake off with the finish.

Penetrating finishes also erode due to photochemical degradation. This leaves a degraded, gray surface that won't bond

with film-forming or latex stain finishes. However, oil-based semitransparent stains actually bond better to a slightly weathered surface.

With the breakdown of the finish, the second punch, in the form of moisture, delivers a much deeper blow, especially through end grain. It saturates the wood's fibers, making them swell, much more in width than in length. In colder climates, this moisture can freeze, prying fibers apart. During warm, dry periods with exposure to direct sunlight, the wood gives up moisture and contracts unevenly. The result of these swelling and contracting cycles: The

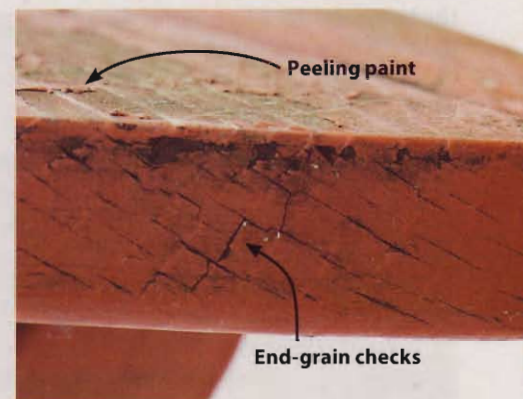

end grain splits and checks, as shown above; and radial cracks appear along

the length of parts, as shown at *right*—particularly in non-kiln-dried wood.

Also, when moisture spreads on the underside of a finish, it makes the finish lose its grip, causing film-forming finishes, such as polyurethane and paint, to flake or blister. But the worst-case scenario occurs when the wood's moisture content (MC) exceeds 30 percent: Microorganisms break apart wood fibers, create sponginess, and lead to total rot, as shown at *right*. (Note that 12–19 MC is typical of kiln-dried softwoods, 6–8 MC for kiln-dried hardwoods.)

Finally, we can't talk about failed finishes without touching on poor wood preparation, inadequate finish coverage, moisture penetration via hardware holes, mildew, and critters. We'll cover those next.

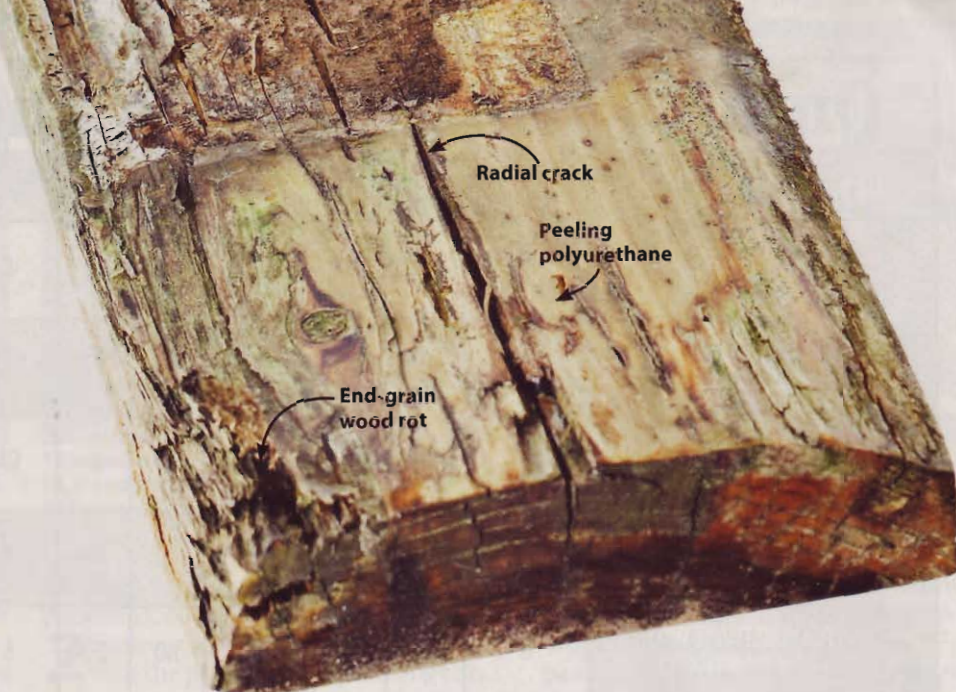

Planned maintenance for guys hating repair work

If you turned over a finished project to Mother Nature in the last few years, and haven't yet detected any telltale signs of wear—flaking, exposed graying wood, cracks in the finish and wood—check out the chart on the *previous page* to see if it's about time to renew that finish. If so, first wash the surface. Keep the water pressure low and the nozzle 15–18" away from the wood to avoid "fuzzing" the surface, as shown at *right*. Let the wood dry out for at least two days before sanding with 50- to 80-grit paper. Finally, reseal end grain with a water-repellent preservative, even if you plan to paint the piece.

If you've never built an outdoor project but are on the verge of doing so, make sure you use a wood capable of giving the project a fighting chance. (See "Woods that say 'nay' to decay," *below*.) Then apply a finish that best suits your needs. For best results, keep the bare-wood project out of direct sunlight prior to finishing. Even a little bit of exposure can harm the finish-to-wood bond.



Pressure-washing this deck railing raised wispy wood fibers, a process called "fuzzing."

One final note: Project hardware, particularly fasteners, provides inroads for moisture into a wood part's interior. If dealing with bolt or predrilled screw holes, coat these with a penetrating finish before installing the hardware. Seal the heads with an exterior putty; counterbore and plug screw holes.

Unfortunately for those who love wood's rich look, its grain and natural color, you may find that love costly in terms of time. Clear penetrating and film-forming finishes do a less-effective

job than semitransparent penetrating stains and paint at combating destructive UV rays. That means more frequent reapplications. When choosing a finish, decide up front how much work you want to do down the road, and then stick to the maintenance schedule for that choice. Once applied, reduce finish deterioration by keeping the project out of direct sunlight, if possible, and covering or storing it away during nonuse months. Also, avoid placing outdoor projects where standing water collects.

Woods that say "nay" to decay

Though all wood eventually decays, some species take longer and prove more resistant to rot and insect invasion. These include pressure-treated pine, redwood, cedar, cypress, ipe, white oak, mahogany, and teak. The last two are pricey, so reserve them for small projects. If using

treated pine, apply water repellent to all exposed surfaces upon project completion. If painting or staining treated pine, wait one or two weeks for the wood to dry before application. On the flip side, avoid untreated pine, poplar, maple, and red oak, as they lose the rot race every time.

Hands-on fixes for your most weather-worn projects

Don't feel bad if an outdoor project or two has gotten nasty-looking on you. It may not be too late to salvage both the project and your pride as a woodworker. Try these strategies to right the wrongs in your past.

ROT REQUIRES REPLACEMENT



Inspect your wood outdoor projects by poking and picking at them with an awl. If you detect soft, deteriorated, and crumbly surfaces, or severely split project parts, replace them.

PRIME TIME FOR FAILED PAINTED SURFACES



Treat flaking or peeling finishes by sanding the damaged areas down to bare wood before reapplying finish. If you're dealing with a painted finish, apply an exterior primer before repainting.

CHECK MATE: SEAL THE DEAL WITH GLUE



Seal checks in end grain by pressing an exterior-grade wood glue into them using a pliable putty knife or piece of flexible plastic. A hotel room card key or old credit card works well.

MAKE WEATHERED SURFACES EVEN-STEVEN



As shown in the *inset* photo, early- and latewood rings weather at different rates, leaving ridges. Flatten them by sanding with 80 grit (working up through 150 grit only for furniture).

BID ADIEU TO MOLD AND MILDEW



Scrub mold or mildew into oblivion with a nonchlorinated "oxy"-type cleaner containing sodium percarbonate (available at home centers). Wear gloves and eye protection. Rinse after scrubbing.

RENEW GRAY AND DISCOLORED WOOD



A commercial wood brightener and conditioner can restore some color to a grayed surface, especially within the first year or so. Brush or spray it on; then wash it off. After drying, sand and refinish. 🌲

Tablesaw Blade Locker

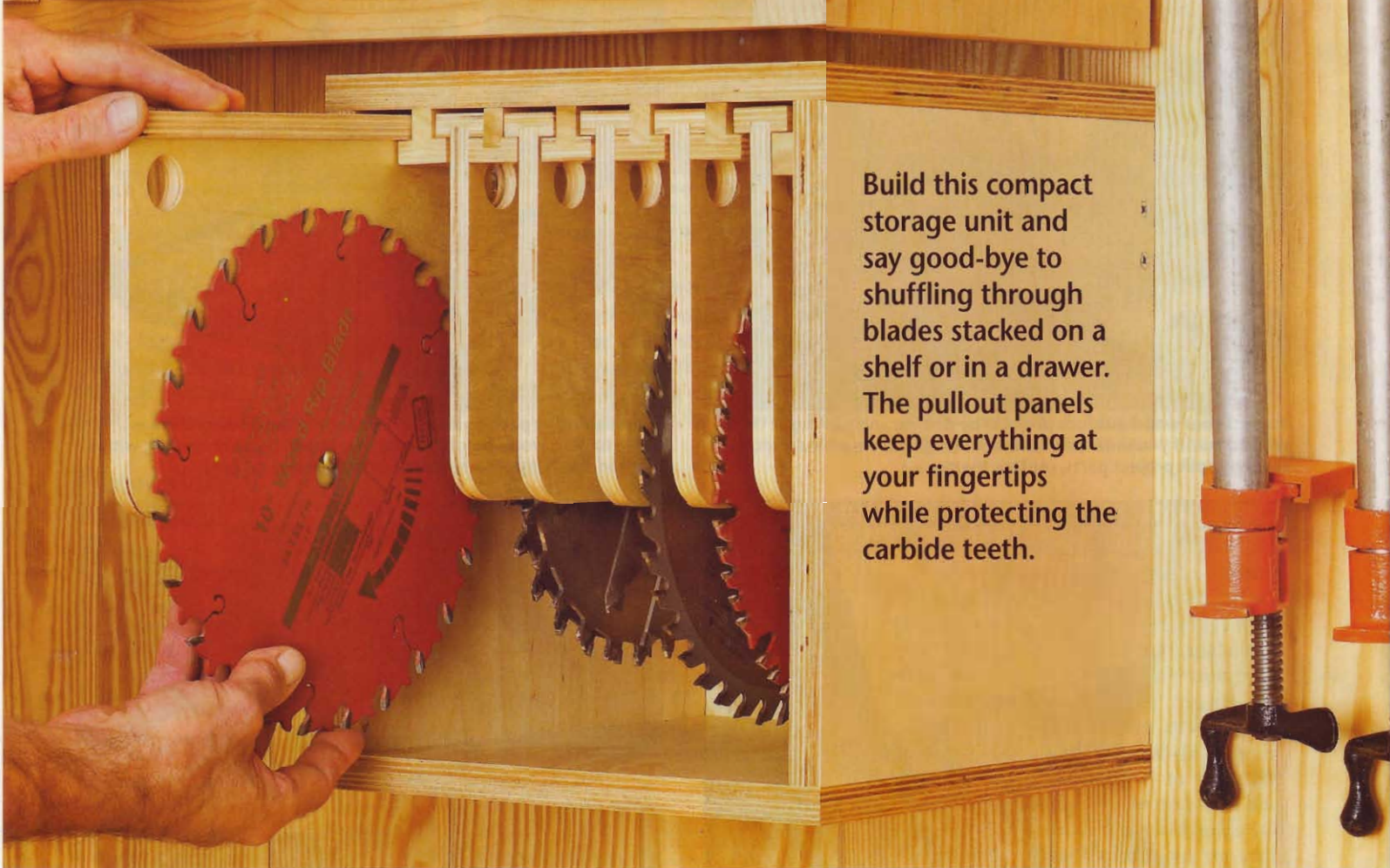

Build this compact storage unit and say good-bye to shuffling through blades stacked on a shelf or in a drawer. The pullout panels keep everything at your fingertips while protecting the carbide teeth.

PROJECT HIGHLIGHTS

- Overall dimensions: 11½" wide × 12" deep × 13¾" high.
- Stores a stack dado set and six 10" saw blades.
- Expand it to store additional blades by making a wider case and adding more pull-out boards.
- Hang your dado set on three pullout boards so you can get right to the blades and chippers you need.
- A pair of interlocking cleats makes wall-mounting a snap.
- If space allows, use the top of the case as a shelf and hang tablesaw accessories, such as throat plates and pushsticks, from the sides.
- For the lumber and other items needed to build this project, see the next page, bottom.

1 Cut the parts to size

- Cut the rails (A) and panels (B) to size [Materials List, below].
- From ⅛" tempered hardboard, cut the stops (C) to size.
- Plane stock to the same thickness as the ½" plywood, and cut the cleats (D) to size.

- Cut the top and bottom (E) and sides (F) to size. Then cut the case cleat (G) and wall cleat (H) to width and ¼" longer than listed. Rip 45° bevels on the mating edges of the case cleat and wall cleat [Drawing, below].

Materials List

Part	FINISHED SIZE			Matl.	Qty.
	T	W	L		
A rails	½"	1⅞"	12"	BP	11
B panels	½"	7"	11¼"	BP	6
C stops	⅛"	½"	1"	H	12
D cleats	½"	¾"	12"	P	7
E top and bottom	¾"	12"	11½"	BP	2
F sides	¾"	12"	12¼"	BP	2
G* case cleat	¾"	2½"	10"	BP	1
H* wall cleat	¾"	7"	9¾"	BP	1

*Parts initially cut oversize. See the instructions.

Materials key: BP—birch plywood, H—tempered hardboard, P—poplar.

Supplies: #8×1½" and #8×2½" flathead wood screws, #10×¾" brass roundhead wood screws.

Blade and bits: Stack dado set, 1" Forstner bit.

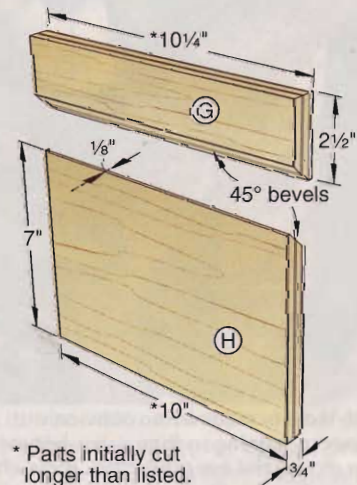

* Parts initially cut longer than listed.

2 Make the pullout boards

■ Adjust a dado blade to cut a groove to match the thickness of the $\frac{1}{2}$ " plywood panels (B). Then cut a centered $\frac{3}{16}$ "-deep groove into each rail (A).

■ Chuck a 1" Forstner bit into your drill press and drill a finger-pull hole into each panel (B). Mark 1" radii on the panel bottom corners. Saw and sand

them to shape. Drill two $\frac{1}{8}$ " holes into each panel for #10 roundhead screws.

■ Glue and clamp a rail (A) to the top edge of each panel (B), with both parts flush at the front.

■ Glue and clamp a stop (C) to the upper rear corner of each panel (B) on both sides.

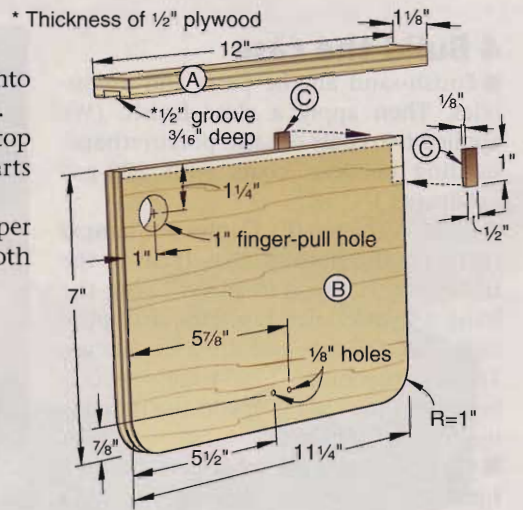

3 Assemble the hangers

■ To form the ends of the 9"-long notches in the rails (A) of the hangers (A/D), fit your tablesaw miter gauge with an extension and stopblock. Then cut $\frac{1}{8}$ " saw kerfs $\frac{1}{8}$ " deep into both edges of each rail 3" from the front end [Drawing, below right].

■ Glue and clamp a cleat (D) into the rail (A) grooves, flush at the ends. Then, to complete the 9"-long rail notches, position your bandsaw fence 1" from the blade. With the hanger (A/D) rails (A) up, cut to the saw kerf [Photo A]. Next measure the distance from the cleat (D) to the edge of the rail, and cut a spacer to this width and the length of the bandsaw

fence. Clamp the spacer to the fence $\frac{1}{2}$ " above the bandsaw table. Now rotate the hangers, and with the rails down, cut the opposite notches [Photo B].

■ Drill three countersunk holes through each hanger (A/D) [Drawing, below].

■ Retrieve the sides (F) and the remaining cleats (D). Glue and clamp the cleats to the inside faces of the sides [Drawing, below].

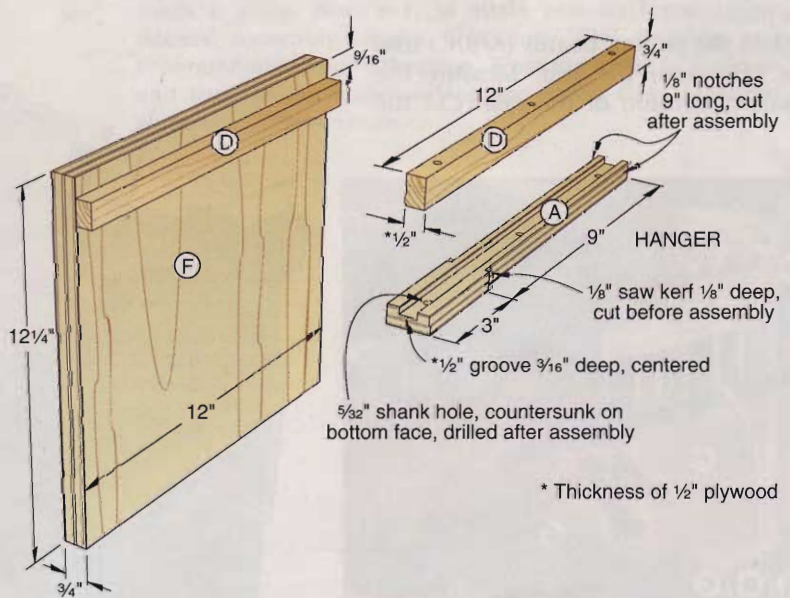
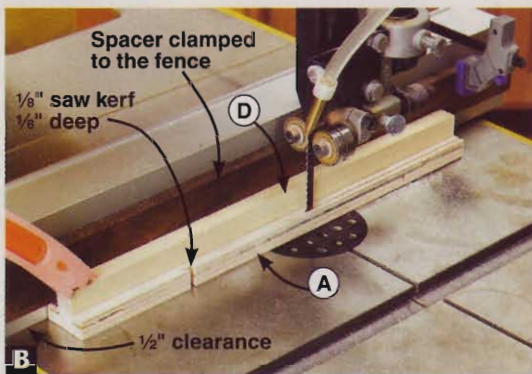
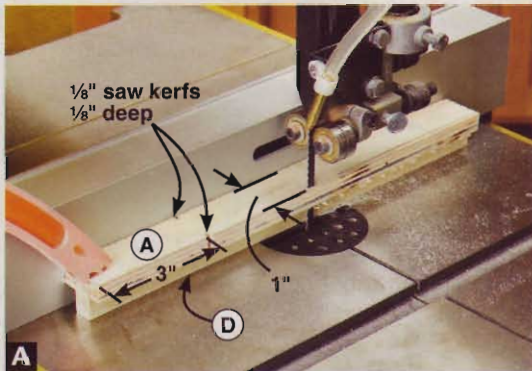

Cutting Diagram

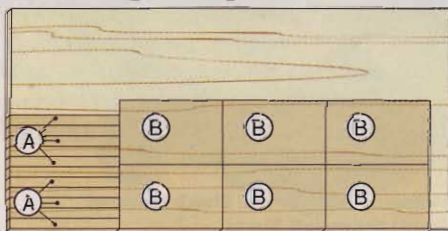

$\frac{1}{2}$ x 24 x 48" Birch plywood

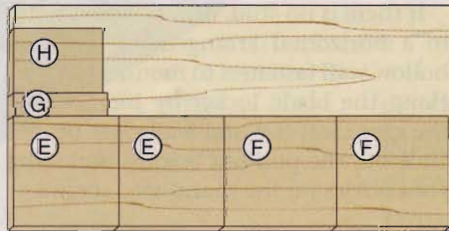

$\frac{3}{4}$ x 24 x 48" Birch plywood

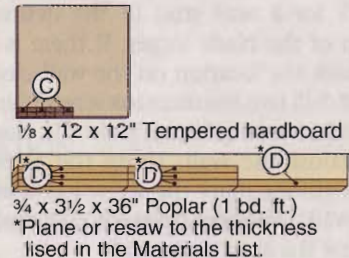

$\frac{1}{8}$ x 12 x 12" Tempered hardboard
 $\frac{3}{4}$ x 3 1/2 x 36" Poplar (1 bd. ft.)
 *Plane or resaw to the thickness listed in the Materials List.

4 Build the case

■ Finish-sand all the parts and assemblies. Then apply a clear finish. (We applied two coats of satin polyurethane, sanding between coats with 220-grit sandpaper.)

■ Retrieve the top (E). Center one hanger (A/D) on the bottom face, flush at the front, and clamp it in place. Using the hanger shank holes as guides, drill pilot holes into the top, and drive the screws. Then, inserting 1 $\frac{1}{32}$ "-wide spacers between the cleats (D), add the remaining hangers [Photo C].

■ Clamp the top assembly (A/D/E), bottom (E), and side assemblies (D/F) together, flush all around. Then drill countersunk screw holes through the top and bottom (E) and into the sides (F) [Drawing, far right]. Drive the screws.

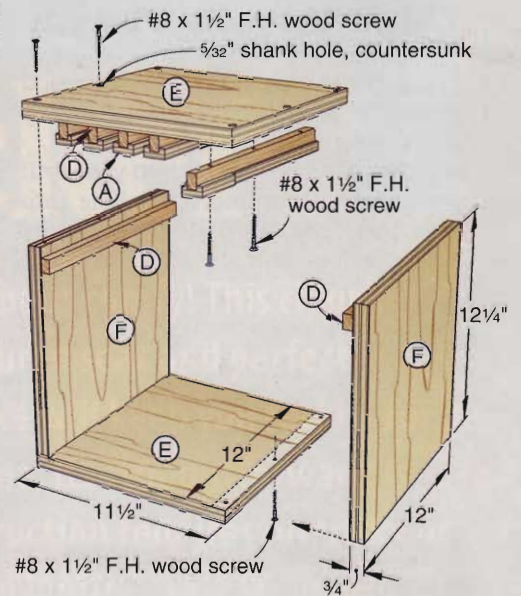

5 Assemble the locker

■ Drive roundhead screws into the 1/8" pilot holes in the panels (B) of the pullout boards (A/B/C) [Drawing, right]. Leave 3/16" between the head of the screw and the panel [Screw Detail]. File the protruding screw points flush on the opposite side of the panel.

■ Slide the pullout boards (A/B/C) into the case from the rear. Measure the inside dimension of the case. Cut the

case cleat (G) to this length. Then cut the wall cleat (H) 1/4" less than this length. Position the case cleat between the sides (F), flush with the back edges and snug against the bottoms of the side cleats (D). Clamp the case cleat in place.

Drill countersunk screw holes through the sides and into the case cleat. Drive the screws [Photo D].

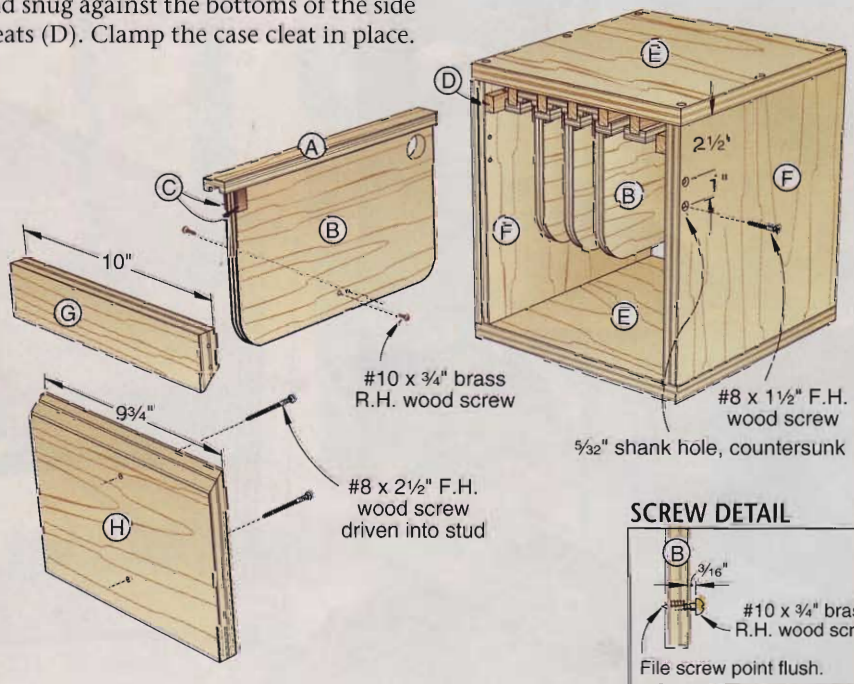

SCREW DETAIL

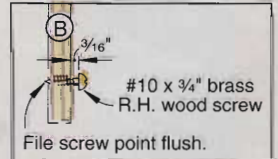

6 Now hang it up

■ Check for a wall stud in the desired location of the blade locker. If there is a stud, mark the location on the wall cleat (H), and drill two countersunk screw holes in a vertical arrangement. Hold the cleat level against the wall. Using the screw holes as guides, mark the screw locations on the wall. Drill pilot holes into the stud, and screw the cleat to the wall.

If there is no stud, drill the cleat holes in a horizontal arrangement, and use hollow wall fasteners to mount the cleat. Hang the blade locker by interlocking the case cleat (G) and wall cleat bevels. Slide out the pull-out boards, and hang your blades on the roundhead screws.

Note: To allow the case cleat (G) to clear the wall cleat (H) when mounting the blade locker under an overhead obstruction, such as a wall cabinet, draw a level line 1" below the obstruction, and align the bottom of the wall cleat with this line.

Written by **Jan Svec** with **Chuck Hedlund**
Project design: **Jeff Mertz**
Illustrations: **Roxanne LeMoine; Lorna Johnson**

6 Basic Skills *Every* Woodworker Should Know

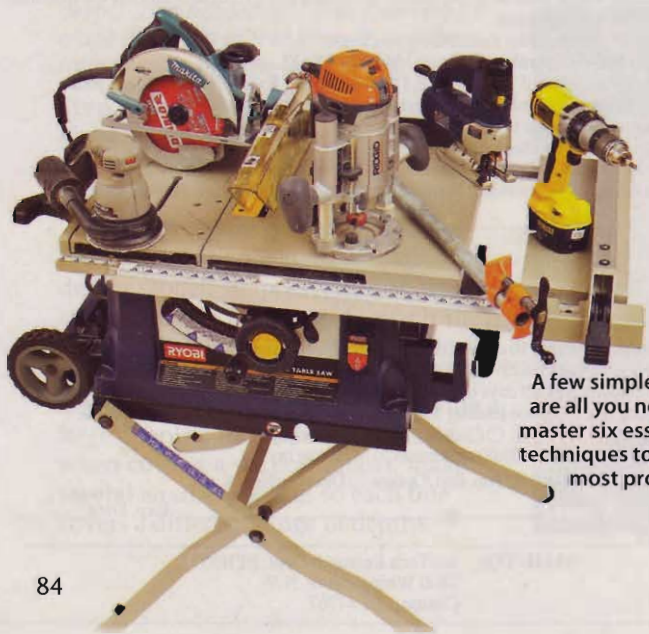
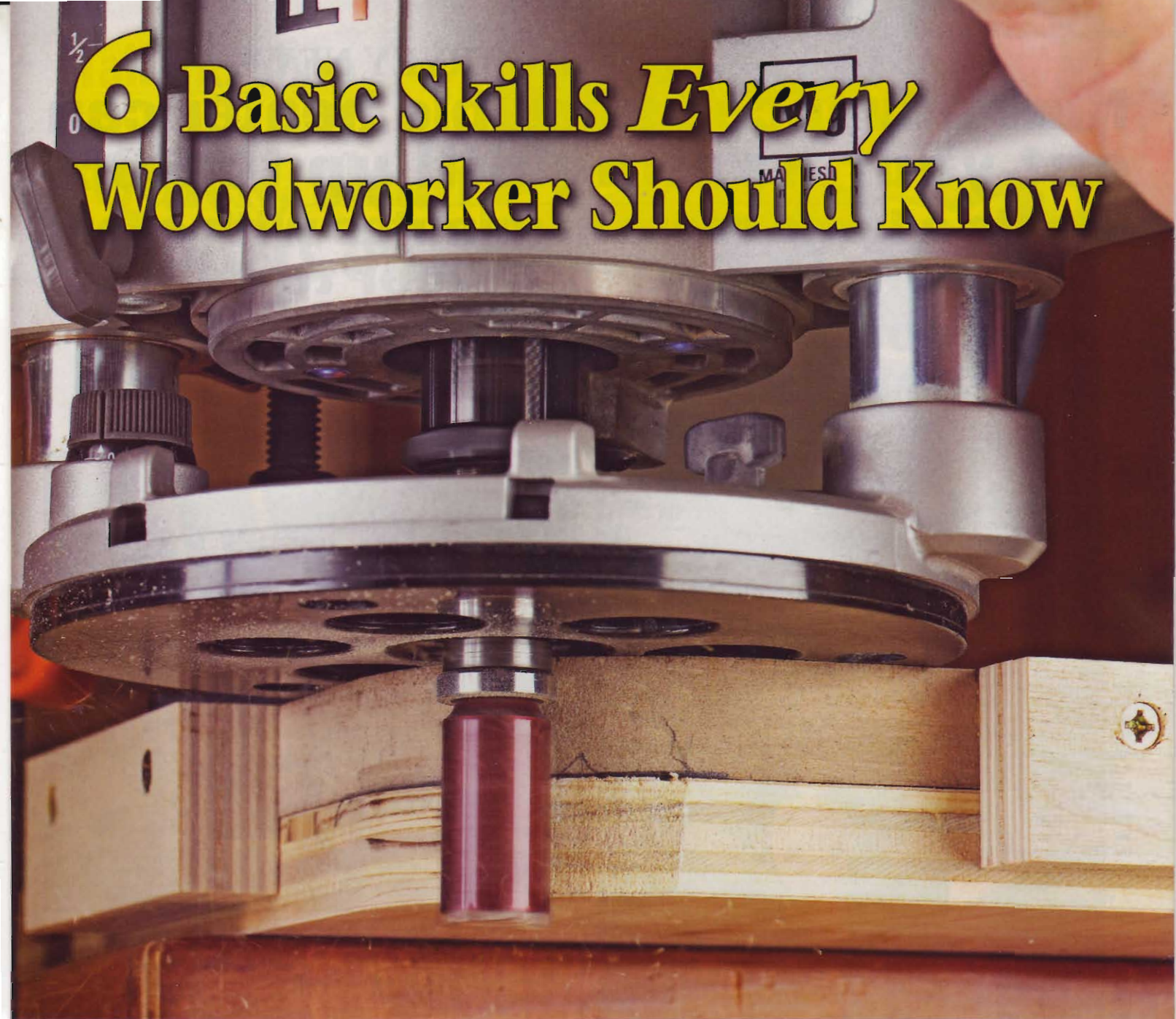

A few simple tools are all you need to master six essential techniques to build most projects.



Watch FREE videos on these techniques at woodmagazine.com/videos

Sure, it's great to have a shop full of pro-quality tools, but you don't need them to craft the Basic-Built projects in *WOOD*® magazine. You can accurately cut, drill, joint, and glue up parts using only inexpensive equipment.

For starters, we're going to assume you have at least some common hand tools and measuring devices, and these few essential power tools shown at left: a benchtop tablesaw, circular saw, jigsaw, a plunge router with a basic assortment of bits, a cordless or electric drill, and a random-orbit sander. You'll also need a few inexpensive pipe clamps and budget-priced accessories such as a \$14 drilling guide. Now, let's see how much you can do with so few tools.

SKILL 1 SAW ARROW-STRAIGHT LINES WITH A CIRCULAR SAW

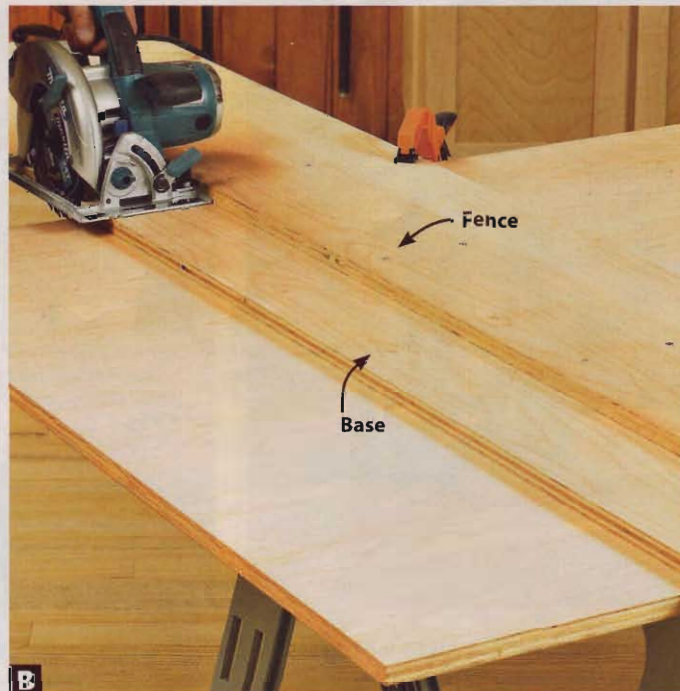
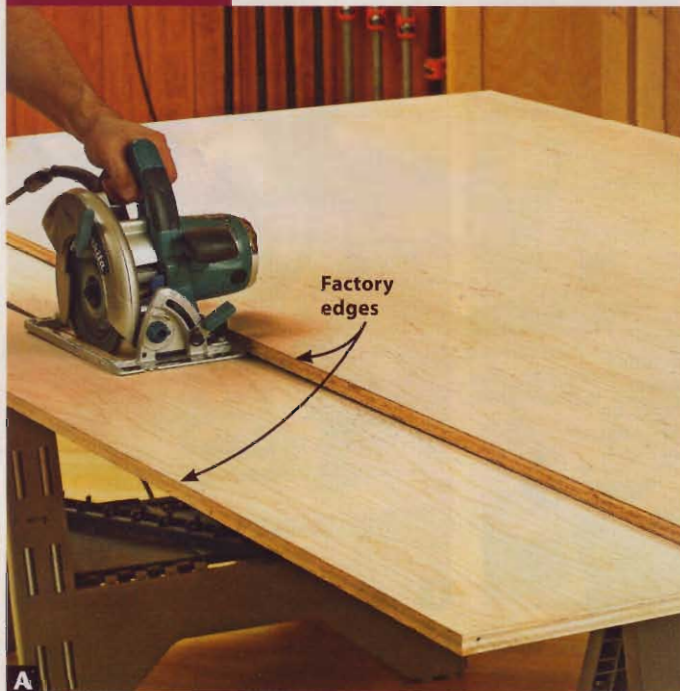

Large sheet goods, such as plywood or medium-density fiberboard (MDF), are too unwieldy to cut on a benchtop saw. By making an 8' straightedge, however, you can cut sheet goods precisely using only a circular saw.

1 You need a straight edge to make a straightedge, so either rough-cut a single plywood sheet in half or stagger two sheets so the top sheet's factory edge acts as a straightedge for ripping a 7"-wide strip off the lower sheet [Photo A]. Then, reposition the top sheet's factory edge to rip another strip roughly 16" wide off the bottom sheet.

2 With the circular saw unplugged, measure from the blade to the edge of the saw base beneath the saw's motor. Add up to 1" to that dimension and then screw the 7"-wide strip onto the 16"-wide lower strip that distance from one edge.

3 Place the saw base firmly against the edge of the upper strip (the *fence*) and cut away the surplus on the lower strip (the *base*) [Photo B]. Support the waste piece, or have a helper hold it steady to keep the saw from binding. Label the saw side of the straight edge. (You can turn the other side into a router guide—more on that in the next section.) If you have more than one circular saw, write on the straightedge the saw make and model.

4 To cut a project part, clamp the edge of the base onto the pencil marks defining your cutline. Then, run the saw-base edge against the upper strip [Photo C] to guide the cut.



SHOP TIP

Add teeth to your circ saw

Most people buy circular saws for remodeling and construction work, not to make clean, splinter-free cuts for woodworking. If your circular saw produces too much tear-out, replace the original 24-tooth blade with a 40-tooth aftermarket blade.



SHOP TIP

Adjust blade depth to your stock thickness

We used sawhorses that could be topped with sacrificial 2x4s (see **Sources**) for cutting and routing sheet goods. If you're using other types of sawhorses, attach replaceable 2x4 tops with fasteners placed well clear of the saw blade. Set the blade or bit to cut no more than $\frac{3}{16}$ " into the sacrificial 2x4s.



SKILL 2 JOINT BOARDS FOR GAP-FREE EDGE-GLUING

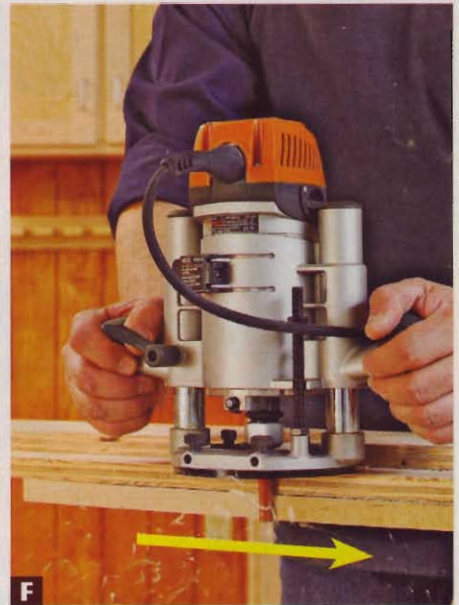

No matter how straight a board looks in the home center, it's likely not straight enough to edge-glide without leaving unsightly gaps that weaken the glue joint. To make those edges true as can be, turn the other edge of your newly built saw guide into a router guide, and then straighten, or "joint," boards using a 1/2"-diameter straight bit or spiral bit. (Remember to use the same bit diameter for future edging.)

1 With the straight bit installed, measure from the edge of the bit to the edge of the router base.

2 Along the length of the guide's base, mark a line that distance from the fence. Saw off the excess base to within 1/8" of the waste side of the line.

3 Adjust the router bit height to cut just deeper than the thickness of the base [Photo D]. Then, clamp the guide to the sawhorses to keep it from shifting. While holding the router base tight against the fence, rout the rough edge smooth. Label the router guide side with the router used (if you have more than one), and a reminder arrow showing the correct router travel direction [Photo E].

4 To joint a board for a glue-up, place the guide-base edges near the edge of your workpiece, leaving a strip about 1/16" wide to be routed straight. Clamp the guide in position, and rout the board [Photo F]. If your tablesaw can handle the size workpiece you're jointing, place the routed edge against your tablesaw fence, and cut a straight and parallel edge on the opposite side. Otherwise, move and reclamp the guide to rout that edge, as you did the opposite one. You also can use this technique to remove rounded factory edges on 2x4s.

SKILL 3 CLAMP AND SAND PANELS FLAT



Purchased lumber can vary enough in thickness to show "steps" on an edge-glued panel. Fortunately, most panels need only one "good" face. To keep at least one surface flat, edge-glide panel pieces with the appearance side

down and pressed firmly against the clamp bars or pipes as you apply clamping pressure. (See the **Shop Tip** at right.)

1 Cover the clamp bars or pipes with painter's tape where the pieces will rest. That prevents the metal from discoloring the wood and simplifies removing glue squeeze-out.

2 Press the pieces down onto the clamps as you tighten them. Leave the glue-up clamped for an hour, then remove the clamps while the squeeze-out remains soft enough to scrape off. Allow the glue-up to dry overnight.

3 Working on only the appearance side, use a random-orbit sander with 80- or 100-grit abrasive to level the joint lines, as shown [Photo G]. Avoid creating a trough in the surface above each joint by continually moving the sander and smoothing the entire panel evenly.

SHOP TIP

Flat panels on round pipe

You can't be too rich, too attractive, or have too many clamps, but you can have too varied an assortment of clamps. So when you buy pipe clamps, stick to one model. Identical clamps support a glue-up on a flat plane better than a mix of clamps with bars at varied heights.

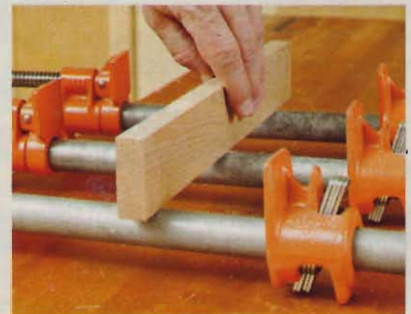

SKILL 4 ROUT PERFECT-FIT DADOES FIRST TIME, EVERY TIME

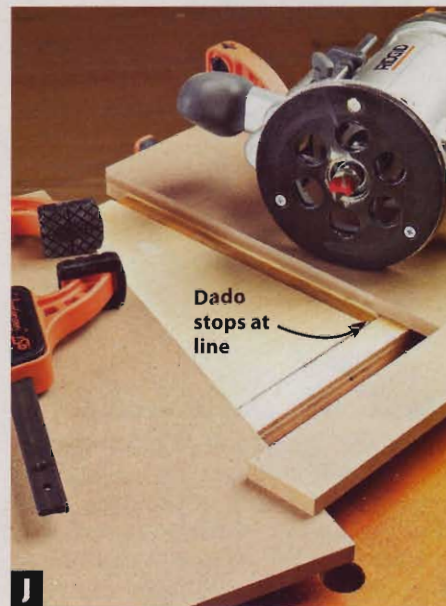
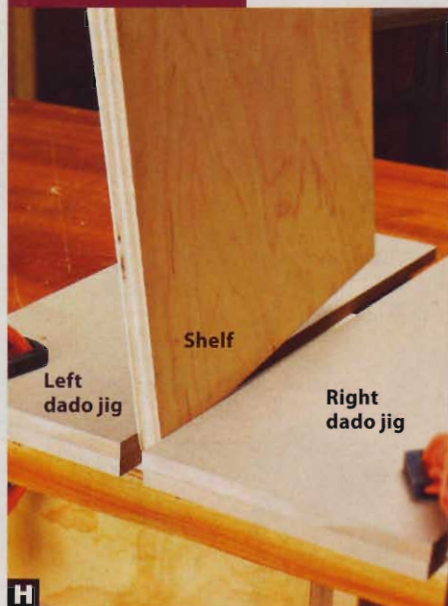

Rout dadoes of any width using what may be the world's simplest jig. It works with any straight bit that is slightly narrower than the thickness of your stock.

From $\frac{1}{2}$ " or $\frac{3}{4}$ " MDF, cut two jig top pieces the same size, as shown at *right*. Make both about 6" longer than the path of your dadoes. Then, cut two cleats 2" wide and as long as the width of the top pieces. Glue a cleat to the underside of each top piece, making it dead-on perpendicular to the long edge. Now, you're ready to dado.

1 Mark the left edge of where you'll dado the workpiece. Then, clamp one jig in place so the right edge of the jig touches the dado mark and the cleat presses against the workpiece edge. Butt the finish-sanded part you'll insert into the dado against the right edge of the jig, and slide the right dado jig up against the part. Clamp the right dado jig in place, and lift off the part between the jigs [Photo H].

2To dado the workpiece, install a $\frac{1}{2}$ "-diameter flush-trim bit (for dadoes wider than $\frac{1}{2}$ " with a top-mounted bearing and a roughly $\frac{1}{2}$ " cutting depth. (See **Sources**.) Make the bit height the depth of your dado plus the thickness of the jig. Press the bit against the edge of one jig just off the workpiece, and turn on your router. Keeping the bit against the jig, work from left to right until you reach the opposite side of the workpiece. Then, repeat against the opposite jig until you have a full-width dado.

3To make a stopped dado, first cut a third 2"-wide strip that's twice as long as the width of the top pieces to use as a stop.

Mark the workpiece where you want the dado to end, then position your jigs, as before. With the dado bit just above the workpiece

as the base rests on the jigs, position the router so the bit just touches the stop line. Using double-faced tape, attach the stop one of the jigs so the stop is perpendicular to the long edge of the jig and halts the router at the stop mark [Photo I]. Set the cutting depth, and rout to the stopblock. Repeat as needed to complete the dado [Photo J].

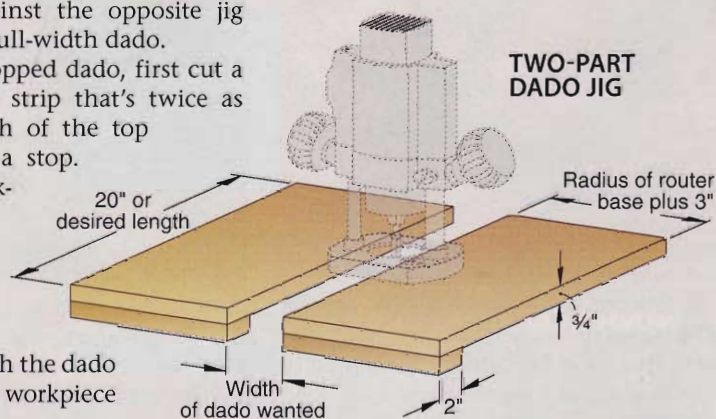

SHOP TIP

Start your router-bit collection with these essentials

Your router-bit investment can add up fast, but it pays to invest in top quality when buying bits you'll use frequently. Whenever possible, buy bits with sturdy $\frac{1}{2}$ " shanks. Here's what to include in a starter set:

- 1 $\frac{1}{8}$ " round-over with a bottom bearing. (It's mounted at the end opposite the shank.)
- 2 $\frac{1}{2}$ "-diameter flush-trim bit with a 1"-long cutting length and a top-mounted bearing.
- 3 $\frac{1}{4}$ " round-over with a bottom bearing.
- 4 $\frac{1}{2}$ "-diameter straight bit with a 1"-long cutting length.

Once you step up to a router table, you'll want a similar bit but with a bottom bearing.

- 5 45° chamfer bit with a bottom bearing.
- 6 Rabbeting-bit kit with different-size guide bearings to adjust the depth of cut.

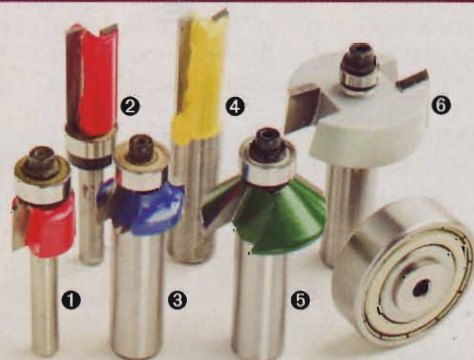

SKILL 5 BORE PERPENDICULAR HOLES WITHOUT A DRILL PRESS



K

Portable drills can't match the accuracy of a drill press for making perpendicular holes, but you can come close using either of these techniques.

A doweling jig [Photo K] (see Sources) can double as a drill guide by starting a hole using the appropriate guide bushing. Then, guided by the shallow starter hole, drill through the workpiece.

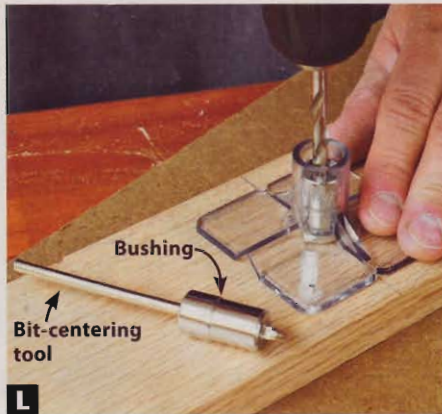

L

You also can drill more accurately aided by a \$14 jig [Photo L]. (See Sources.) You're limited to bits the same diameters as the six bushings provided, but that's more selection than with the doweling jig. Should you step up to a drill press someday, you still can use this jig to drill into spheres, the sides of dowels, or a workpiece edge.

SHOP TIP

Get the (brad) point

Nothing frustrates like watching a twist bit scoot away from the carefully marked location where you meant to drill a hole. With a brad-point bit, however, the tip stays planted where you want it. Start with a basic set, and save them just for woodworking.

Twist bit

Brad-point bit



SKILL 6 HONE YOUR CORNERING ABILITIES



M

Another easy-to-make jig lets you rout rounded corners of any diameter time after time. Make the jig from MDF or plywood about 6–8" square. On one corner of the square, use a compass to draw a quarter circle the radius you want. With a jigsaw, cut within 1/16" of the compass pencil mark without crossing it. Use a hardwood sanding block to smooth the curve down to the pencil mark. Then



N

attach a pair of cleats to the edges adjoining the curve, keeping the cleats at least 1" away from where the curve starts.

1 To start, press the jig cleats against the workpiece corner, as shown [Photo M], and trace the curve.

2 Jigsaw to within 1/8" of your pencil line, as shown [Photo N].

3 Now, turn your jig into a router template, clamping it to the workpiece



O

Bearing rides against template.

so your router can move freely around the corner.

4 Adjust a 1"-long pattern bit to make the top-mounted bearing ride against the jig atop the workpiece, as shown [Photo O]. Then, rout left to right to remove the rough jigsaw edge. 🌲

Written by **Robert Wilson** with **Chuck Hedlund**

Sources

Sawhorses. Storehorse XL, \$20. The Lehigh Group, 800-523-9382 or lehighgroup.com.

Doweling jig. Model G1874, \$32 from Grizzly Industrial, 800-523-4777 or grizzly.com.

Drill guide. No. 140876 with 3/16", 1/4", 5/16", 3/8", 7/16", and 1/2" bushings and centering pin, \$14, Woodcraft, 800-225-1153 or woodcraft.com.

Top-mounted bearing flush-trim bit. Bit no. 16509 with a 1/2"-diameter by 1/2" cutting height, \$16, MLCS, 800-533-9298 or mlcswoodworking.com. Bit no. WL-1007-D with a 1/2"-diameter by 7/16" cutting height, \$14, Woodline, 800-472-6950 or woodline.com.

SHOP TIP

Label jigs for future use

The more woodworking you do, the more jigs you'll collect. Write on the jig its name, important dimensions, and any specific projects where it's used. Then, keep frequently-used jigs within easy reach. Project-specific jigs or those with only a few uses can be stored atop cabinets, hung from overhead joists, or stacked on a high shelf.

SHOP TESTED

Shoulder Planes



For paring tenons and rabbets, nothing does the job better than one of these handy hand tools.

We'll admit it: Most of us on the *WOOD*® magazine staff are dyed-in-the-wool power-tool junkies. So when we confess to having a few favorite hand tools, you know it's because they solve problems that no power tool can. That's the case with a shoulder plane. With its open sides and a blade as wide as its body, you can run the side of a shoulder plane against the wall of a rabbet or the shoulder of a tenon, as shown *above*, and trim an inside cut perfectly square. In fact, a well-tuned and sharpened shoulder plane cleans up corner cuts faster than setting up a power tool to do the job. (See *page 94* for tips on making your joinery airtight using this tool.)

Shoulder planes come in various sizes, shapes, and price ranges, making the task of choosing one daunting. To simplify your choice, we put six models into the able hands of Tim Peters, master furnituremaker, hand-tool aficionado, and head of the woodworking department at Orange Coast College in Costa Mesa, California. After more than a month of testing and daily use by Tim and his students, here are the findings.

First and foremost: Flat and square

If the bottom (or sole) of a plane isn't perfectly flat, you can't expect it to leave a flat surface behind. And on a shoulder plane, a perfectly square intersection

between the sole and sides is equally important (just like the relationship between a jointer bed and its fence). Three of the tested planes—the Clifton 420, Lie-Nielsen 042, and the Veritas 05P41.01—proved sufficiently flat and square out of the box. The rest required some time spent with wet/dry abrasives and float glass to flatten and square them before use. (Learn the complete technique for flattening the sole of a hand plane in *WOOD* magazine issue 160, page 50, or purchase the article at woodmagazine.com/blockplanes.) Once done, and after sharpening the blades (which we'll discuss shortly), all of the planes cut clean, square shoulders on edge, cross, or end grain.

TWIST OR TAP: TWO WAYS TO ADJUST BLADE DEPTH ON A SHOULDER PLANE



A

While sighting down the sole of the plane, you can adjust the cutting depth of most plane blades by turning the depth knob until a sliver of blade just appears through the throat.



B

On the H.N.T. Gordon, tapping the wedge gently with a hammer sets the blade a hair deeper; rapping the top of the plane with your hand retracts the blade slightly. The method is old-school, but effective.

A HOLE IN ONE IMPROVES CONTROL



C

Veritas added a through-hole in the body of the plane into which you may insert a finger for improved grip.

RELIEVED HANDLE EASES GRIP



D

We found rooster-tail handles a bit awkward to use with one hand, but the relief on the bottom of Clifton's handle, shown, enhanced our grip.

Plane and blade settings must be easy and accurate

The tiniest fraction of an inch when setting the depth of a plane blade can make the difference between a perfect shaving and a plane that's a pain. That's why most of the models feature a screw-driven depth adjustment: You loosen the blade a bit and then twist the knob in to deepen the cut, or out to lessen it [Photo A]. On the H.N.T. Gordon plane, though, you tap the wedge or the plane body [Photo B] to change the cutting depth. After a little practice we found this ancient method just as accurate as screw-type adjustments.

You may find after sharpening the blade that you need to skew it slightly to

keep the cutting edge parallel to the sole. In our tests, the Stanley 92 and E.C. Emmerich 710-P proved a little fussier when making this adjustment and locking the blade, mostly because they're the only two planes that require a screwdriver to secure the blade.

Besides cutting depth, you can adjust the thickness of the plane shavings by opening or closing the blade throat. (A smaller gap yields a thinner shaving.) On most planes, the front of the sole slides fore and aft after loosening a screw; on the wooden Clifton and steel Gordon planes, the only throat adjustment is using a needle file to enlarge the throat—a permanent adjustment that can't be undone.

Before you buy, some hand-holding is in order

If a tool doesn't feel good in your hand, you probably won't use it often. So, if possible, make sure you try it before you buy it. Tim says the well-balanced wooden body of the Gordon plane felt best in his medium-size hands, followed closely by the Veritas. The latter has a unique finger hole [Photo C] that we came to like.

You may, instead, like the feel of the long rooster-tail handles on the Clifton [Photo D] and Lie-Nielsen shoulder planes. Between those two, we prefer the finger-cradling concave handle of the Clifton, which gave us a more positive grip.

Every blade needed a good sharpening before use

As we expected, no plane arrived with a blade sharp enough to make great cuts. The "Ease of Sharpening Blade" grades in the chart below reflect Tim's preference for sharpening on waterstones without a honing guide and are based on the amount of time it took to bring the blades to equal sharpness. The beefier $\frac{3}{16}$ " thickness of the Gordon blade (compared with the more typical $\frac{1}{8}$ " thickness) lengthens the bevel of its blade, giving it more surface on the stone for easier sharpening. This grade is less important if you use a honing guide or power sharpener.

Our pick for a shoulder plane you won't cry on

Our favorite plane in this test is the modestly priced Veritas 05P41.01. Near-perfect out of the box, its steel blade took a brilliantly sharp edge, and its comfortable profile encouraged control, which led to excellent cuts.

Although it's a very different plane from the Veritas, we were equally pleased with the performance and comfort of the H.N.T. Gordon. But it did require some up-front work to square the sole to the body. 🌲



Veritas 05P41.01



Lie-Nielsen 042



H.N.T. Gordon



Clifton 420

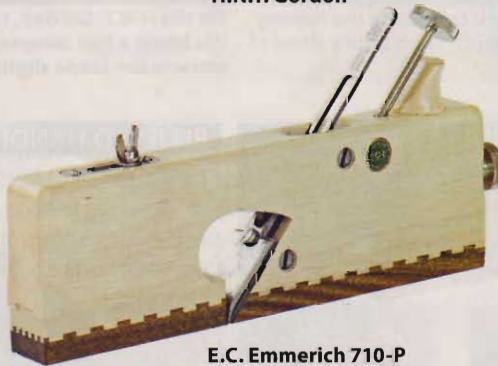

E.C. Emmerich 710-P



Stanley 92

Written by Dave Campbell with Tim Peters

SHOP-TESTED SHOULDER PLANES SHOW THEIR STUFF

BRAND	MODEL	OVERALL DIMENSIONS, INCHES (WxHxL)	BODY MATERIAL (1)	ADJUSTABLE THROAT? (YES, NO)	CUTTING ANGLE, DEGREES (2)	BLADE WIDTH, INCHES	BLADE THICKNESS, INCHES	PERFORMANCE GRADES (3)			WEIGHT, POUNDS	COUNTRY OF ASSEMBLY (5)	SELLING PRICE (6)	WHERE TO BUY	
								EASE OF SETTING CUTTING DEPTH	EASE OF ADJUSTING/LOCKING BLADE	EASE OF SHARPENING BLADE					
CLIFTON	420	$\frac{3}{4} \times 3\frac{3}{4} \times 10$	I	N	43	$\frac{3}{4}$	$\frac{1}{8}$	A	A	B	A-	2.6	E	\$300	traditionalwoodworker.com, 800-509-0081
E.C. EMMERICH	710-P	$1\frac{1}{16} \times 5\frac{1}{2} \times 11\frac{3}{4}$	W	Y	75	$1\frac{1}{16}$	$\frac{1}{8}$	B-	A	B+	B-	1.8	G	\$220	traditionalwoodworker.com, 800-509-0081
LIE-NIELSEN	042	$\frac{3}{4} \times 3\frac{3}{8} \times 9\frac{1}{2}$	I	Y	43	$\frac{3}{4}$	$\frac{9}{32}$	A	A	A	A-	2.3	U	\$175	lie-nielsen.com, 800-327-2520
H.N.T. GORDON	$\frac{3}{4}$ " Shoulder Plane	$\frac{3}{4} \times 2\frac{3}{8} \times 7$	W/B	N	85	$\frac{3}{4}$	$\frac{3}{16}$	B+	A	A-	A	1	A	\$175	craftsmanstudio.com, 888-500-9093
VERITAS	05P41.01	$1\frac{1}{16} \times 3\frac{3}{8} \times 8$	I	Y	40	$1\frac{1}{16}$	$\frac{5}{32}$	A	A	A	A	2.1	C	\$175	leevalley.com, 800-871-8158
STANLEY	92	$\frac{3}{4} \times 2\frac{1}{4} \times 6$	I	Y	40	$\frac{3}{4}$	$\frac{1}{8}$	B-	B	B-	B-	1.1	E	\$105	woodcraft.com, 800-225-1153

NOTES	1. (B) Brass (I) Iron (W) Wood	2. Combination of bevel angle and blade bevel angle.	3. A Excellent B Good	4. In new, unused condition	5. (A) Australia (C) Canada (E) England (G) Germany (U) United States	6. Prices current at time of article production and do not include shipping, where applicable.
-------	--------------------------------------	--	---	-----------------------------	---	--

Just-Right Joinery

Shave Your Way To Tight Tenons

A sharp, well-tuned shoulder plane trims tenons with precision no machine can match.



Watch a FREE video on shoulder planes at: woodmagazine.com/videos

Whether you cut tenons with a tablesaw or a handsaw, you'll craft tighter, stronger joints by gradually trimming each tenon to fit its mortise. A shoulder plane, like the ones reviewed on *page 90*, tunes tenons accurately and quickly, thanks to a blade as wide as the body of the plane and sides square to its sole. Here's how.

To help the tool sail through hardwoods, sharpen the plane blade to a razor's edge. For a free video on quick and easy sharpening, visit the hand tools section of woodmagazine.com/videos. After installing the blade, adjust its cutting depth to remove the thinnest possible shaving, as shown *below*. Then clamp your workpiece to a bench, or brace it against a bench dog to prevent shifting as you work.

Begin the tenon-planing stroke with the blade off the tenon. Keep the plane level and balanced on the tenon as you push it through each stroke, as shown *above right*. In addition to straight passes, you also can plane at a slight diagonal for a shearing action that cuts

PLANE TENONS AS EASY AS ONE, TWO, THREE



1. Start your stroke by pressing the front, or toe, of the plane evenly on the tenon cheek as you push the plane forward. 2. As the blade bites into the wood, continue pushing forward while keeping even pressure on the toe and heel of the plane. 3. Then use the plane's momentum to carry it past the edge of the tenon. Take care not to tilt the heel upward.

easier. Repeat the same number of passes on each cheek (the broad surface of the tenon) to keep the tenon centered. A fine-tuned tenon should fit hand-tight within the mortise.

Why it's a "shoulder" plane

For tablesaw-cut tenons, you'll likely only need to plane the tenon cheeks. For hand-cut tenons, however, you may need to tune the shoulders as well.

To plane a shoulder, rest the plane's side flat on the tenon cheek, as shown *below*, and plane down to the mark defining the shoulder. Take thin shavings to avoid tear-out on the opposite edge. Repeat on the opposite shoulder; then remove the small area in between with a chisel. You also can use a shoulder plane to chamfer the tenon ends about $\frac{1}{8}$ " for easier assembly and a tighter fit.

SET THE SHOULDER PLANE BLADE DEPTH TO TAKE FINE SHAVINGS

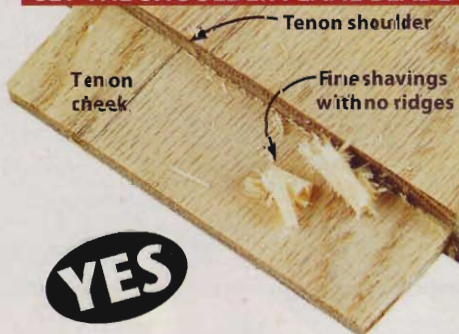

Adjust the blade's cutting depth until it removes fine shavings without leaving visible score marks, as on the *left* tenon. Ridges seen on the *right* tenon mean you're cutting too deep.

PLANE HAND-SAWN SHOULDERS

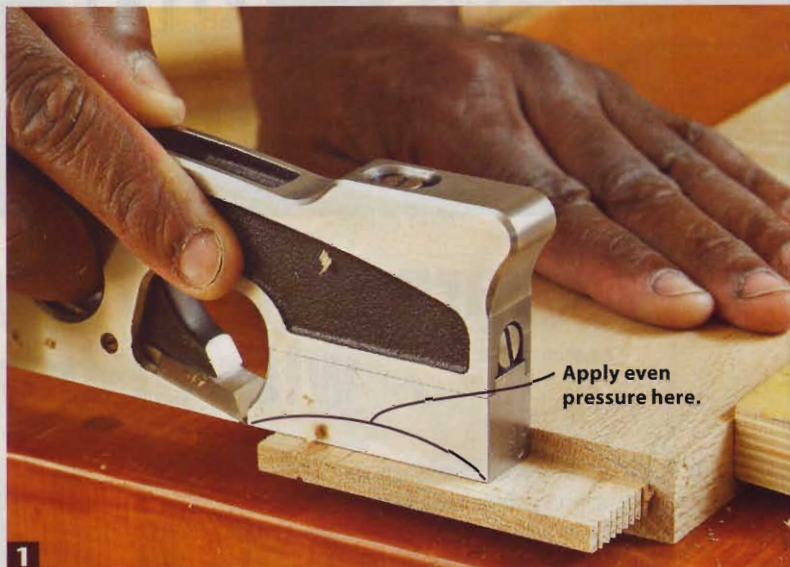
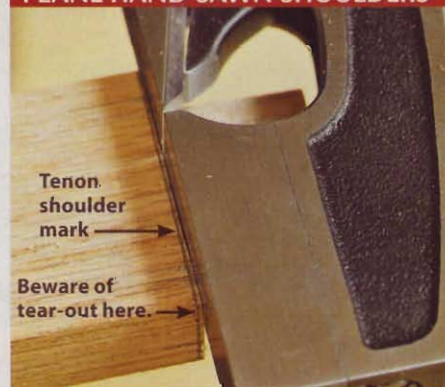

Shop-Proven Products

These woodworking wares passed our shop trials.

About our product tests

We test hundreds of tools and accessories, but only those that earn at least three stars for performance make the final cut and appear in this section.

Resaw bandsaw bestows a powerful performance

I love that feeling of testing a tool and realizing a manufacturer nailed it. That's what happened during my work with Rikon's model #10-325 deluxe 14" bandsaw.

Its 13" resaw capacity is what draws people to this machine. It has that much cutting height because the column equals that of most other bandsaws with a riser block added. And Rikon made the guidepost—which moves on a rack-and-pinion system—extend through the top, allowing the extra resaw capacity without making the overall height too tall.

To test this feature, I installed a new 3/4" Timber Wolf blade and set the guides. This unit powered its way through a 12 7/8"-wide slab of white oak as I resawed pieces as thin as 1/8". The motor never faltered. I used the included pivot bar mounted to the rip fence, but I found resawing with the fence alone superior: I machined sheets that never differed more than 1/32" in thickness.

There's cast iron everywhere: 1"-wide wheels, a 16x21 1/2" table with two miter slots, and substantial table trunnions. The blade tensioner and built-in scale marked in fractions tells you precisely how much to tighten the blade, and the

tension release lever allows the blade to relax when not in use without losing that setting. The 110-volt motor pulls 14 amps, but it never tripped a breaker, thanks to its soft-start feature.

Rikon's L-shaped aluminum rip fence can be mounted either 3/4" tall or 1/2" tall (so it reaches under the blade guides for thin rips on short workpieces). Blades change easily because the slot in the table is perpendicular to the fence rail: Simply pull the blade forward and slide it around the end of the rail. I've used other bandsaws that proved much more difficult. I also like that the base serves as a cabinet to store the fence, miter gauge, resaw pivot, and manual. There's also a worklight, and a holder on the back for the five included hex wrenches needed for all adjustments.

My only knock on this model: The adjustment of the bearing-style blade guides. Setting the side guides correctly proved fussy, but I can live with that in exchange for all the great features.

—Tested by Bob Hunter

14" bandsaw, model #10-325

Performance	★★★★★
Price	\$750
Rikon	
877-884-5167; rikontools.com	



Lee Valley turns up a good value with turning chisels

Lee Valley's nine-piece set of turning chisels will get any turner off to a good start in the hobby—for a reasonable price. The set features a 3/4" roughing gouge; 1/4", 3/8", and 1/2" spindle gouges; a 1/2" bowl gouge; a 1" oval skew chisel; a 3/16" diamond parting tool; a 1" square scraper; and a 1" roundnose scraper. There's also a polyester tool roll for storing or carrying the chisels.

I turned several projects with these tools—big and small bowls, furniture spindles, and drawer pulls—and they performed well after I sharpened each to my satisfaction. I was able to grind the high-speed-steel chisels to create precise cutting edges, and they held those edges throughout prolonged turning better than I expected. The oval-shaped skew proved trickier to sharpen than the flat skews I normally



use, but it cuts well once sharp. I appreciate the 15"-long ash handles, but would prefer handles about 3" shorter on the spindle gouges. I find shorter handles better fit my technique when making tight coves and beads.

—Tested by Brian Simmons

9-piece turning chisel set, model #58B25.30

Performance	★★★★☆
Price	\$165
Lee Valley	
800-871-8158; leevalley.com	

continued on page 98

YOUR WINNING FORMULA

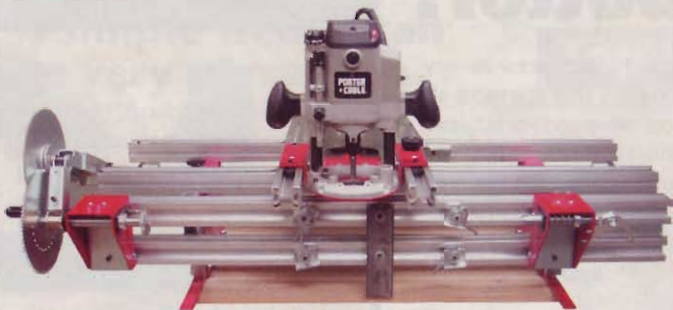

You

**PLUS one Legacy Ornamental Mill
PLUS our FREE On-line
woodworking classes
EQUALS world class results.**



LEARN MORE TODAY AT...

**Legacy Woodworking Machinery
800 279 4570**

www.legacywoodworking.com

**THE RIGHT TOOLS and TRAINING
FOR THE WOODWORKER
WITH A VISION.**

Circle No. 644

Shop-Proven Products



Stainless-steel discs cut fast, not fine

Staring into the teeth of these Stainless Steel Sanding Discs for 5" random-orbit sanders, they look mighty scary. And they are—if you're a piece of wood. The idea behind them: Each razor-sharp hole acts like a tiny hand plane to shave the wood, rather than scratch it smooth, like the grit on sandpaper. But do these hook-and-loop discs leave a surface as smooth as sandpaper?

To find out, I compared Microplane's coarse, medium, and fine Stainless Steel Sanding Discs head-to-head with a fresh set of conventional 40-, 80-, and 120-grit sanding discs. Using the same sander, hand pressure, and an equal number of strokes with each abrasive, I worked my way up through the grits on pieces of red oak and hard maple.

The coarse Stainless Steel Sanding Disc devoured the test boards, leaving tiny wood shavings in its wake. It removed material faster than any sandpaper I've ever used, but the fuzzy and frayed finish wasn't as smooth as the swirly scratches left by 40-grit paper. As I proceeded up through the grits, the Stainless Steel Sanding Discs always left a surface that felt rougher than that made by sandpaper.

I figured that stain would reveal flaws left by either abrasive, so I brushed on a dark stain. Not surprisingly, the wood shaped with the Stainless Steel Sanding Discs took the stain darker and more unevenly than the sanded wood. However, I always sand a project to 180 grit before staining, so I sanded both the 120-grit sandpaper area and the "fine" Microplaned area with equal strokes and pressure, and again applied stain.

This time I couldn't tell one board from the other.

Here's the bottom line: Microplane's Stainless Steel Sanding Discs won't replace your sandpaper, but they will hog away a lot more material for the same effort. And, at about \$5 a disc, they'll last a lot longer before needing replacement.

—Tested by Pat Lowry

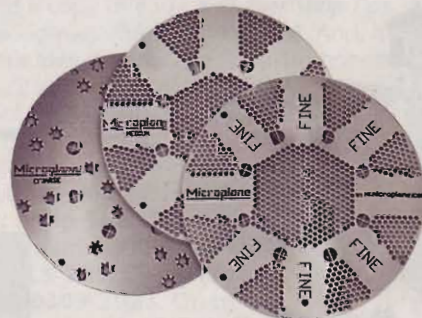

Stainless Steel Sanding Discs

Performance	★★★★☆
Price	\$10, 2-pack; \$14, three-grit assortment
Microplane 800-555-2767; microplane.com	

continued on page 100

Enjoy All the Creature Comforts with Radiant Floor Heating

Compatible with any fuel source:

GAS PROPANE SOLAR OIL WOOD ELECTRIC GEOTHERMAL

VISIT OUR WEBSITE

CALL FOR A FREE QUOTE

www.radiantcompany.com

Barton, Vermont

(toll free) 1.866.WARM-TOES (927.6863)

RADIANT

Floor Company



Circle No. 1301

Shop-Proven Products



Sharpen on the go with these spill-proof stone kits

I work as a cabinetmaker in an 1875-era historical village using nothing but true-to-the-period hand tools. Needless to say, I have to sharpen tools every day. So I recognize a quality sharpening product, such as the Norton Portable Sharpening System, when I see it.

Norton packed its existing tri-hone kit (three stones mounted in triangular fashion on a rotating base) in a leak-proof plastic box with a reservoir bath below the stones. So two stones soak while you use the other. The stones need only 15 minutes in the water before use, so I soak the 1,000- and 4,000- grit stones first. (Norton recommends that you not store the stones in water.) No matter which of those stones I start with, the 8,000-grit stone gets submerged and is ready when I need it. I like the 3x8" stones in this kit better than the 2½x11½" stones in Norton's previous tri-hone. The new stones allow me to sharpen wide plane irons and provide a better platform for my honing guide. The kit also includes a ceramic flattening plate, and I found enough room in the bottom storage tray to hold the honing guide.

Although I got sharp tools using the oilstone version, I found that I could get a much sharper edge on my plane irons with the waterstones. Included in the oilstone kit are a coarse Crystolone stone and medium and fine India stones. 🌳

—Tested by John Olson

Portable Sharpening System

Performance	★★★★★
Price	Waterstone (#IM83-W) \$290; Oilstone (#IM83-O) \$170
Norton Abrasives 254-918-2306; nortonstones.com	

YOU GOT FUNGUS? NAIL IT!

with

FUNGI NAIL BRAND

- ✓ Maximum Strength without a Prescription
- ✓ Twice the Strength of Other Brands
- ✓ Visible Results in Just Weeks
- ✓ No Side Effects

#1
Pharmacists
Recommend!



1-800-824-4894 www.kramelids.com © 2007 Kramel Laboratories, Inc.

FREE!

Nail care set and brochure on how to NAIL your fungus! Call 1800-824-4894

AVAILABLE AT:



Circle No. 1228

WAL-MART



Wise Buys

Our Editors Test

Tool-Triggered Vacuums

Why buy?

Good dust management begins at the tool, which is why we like a tool-triggered vacuum that turns on and off automatically with the tool plugged into it. (Such vacs also switch on/off manually.) Tool-triggered vacs feature high-efficiency filtration, disposable bags to trap debris, a few seconds of run time to clear the hose after you switch off the tool, and considerably lower noise levels compared with typical tub-style shop vacuums. Two variables to watch for: Dust ports on portable power tools vary so much in size and shape that we often had to use adapters (and sometimes duct tape) to attach the vacuum hoses. And, the capacity of the on-board outlet will likely limit you to using the vacuum with low-amperage tools, such as sanders, biscuit joiners, or midsize routers, because all but one of the vacs' power cords are rated for only 15 amps. Do not exceed the manufacturers' stated power availability.

SHOP-VAC ON-DEMAND 925-63-10, \$200

Editor test-drive:

My basement workshop is right below my bedroom. So not only do I appreciate the quietness of Shop-Vac's On-Demand vacuum, but so does my wife when I'm working late at night. Whether I used the cartridge filter alone (with chips falling into the tub) or with the collection bag (which traps nearly all of the dust and chips), it sucked up every mess I made. The hose flexes enough for good maneuverability without being too soft and crush-prone. The On-Demand worked great with my random-orbit sander, but when I used it with my 3-hp router, an onboard electronic controller reduced power to the vac motor, which reduced suction. (Shop-Vac says this could damage the motors on one or both tools.)



Capacity: 12 gallons
Hose: 1 1/4" x 12'
Tool Amps: 8; Noise Level: 78 dB

—Tested by Jan Svec, Projects Editor

To learn more:

570-326-0502; shopvac.com

PORTER-CABLE 7812, \$270

Editor test-drive:

I've used Porter-Cable's older model #7810 for years for general shop cleanup and dry-wall sanding, and the newer model #7812 performs even better. Weighing only 20 lbs., it has all the suction I need to collect dust from my portable power tools. The oversize rear wheels make it stable, and it glides easily around my shop without tipping. The 7812 comes with a cartridge filter and one collection bag. It features a spring-loaded "finger" on the outside that when you pull, drags across the filter and knocks off most of the dust without opening the hood. I had no trouble connecting the hose to my Porter-Cable tools, but mixed luck with other brands.



Capacity: 10 gallons
Hose: 1 1/2" x 13'
Tool Amps: 6; Noise Level: 75 dB

—Tested by Bill Krier, Editor-in-Chief

To learn more:

888-848-5175; deltaportercable.com

FEIN TURBO III 9-77-25, \$400

Editor test-drive:

This vacuum is so quiet when I powered up my first few tools, I had to touch it to verify it was running. In fact, the Turbo III rates as the quietest in our test and about 40dB lower than my regular shop vacuum. I also appreciate its suction, as it gobbled up all the wood dust and chips I could make. It comes standard with a paper collection bag that traps nearly everything, and a 5-micron cloth filter that works great for trapping dust as the heavier debris falls to the bottom of the tub. I could hook up all but one of my tools using the included hose and reducing adapter. Although the vac's outlet lists 18 amps of possible power, I found—using an ammeter—that its motor drew 10 amps. So that leaves only 5 amps for a tool on its 15-amp-rated cord and plug. Exceeding this could damage the tool or vacuum motors.



Capacity: 14.5 gallons
Hose: 2 1/4" x 10'
Tool Amps: 5; Noise Level: 67 dB

—Tested by Dave Campbell, Deputy Editor

To learn more:

800-441-9878; feinusa.com

FESTOOL CT22, \$450

Editor test-drive:

I never thought I'd pay \$450 for a vacuum, but after using the CT22, I'm sold. It comes standard with a filter that traps dust as small as 0.3 microns—the finest filtration in the test. And its suction swallowed everything to where I couldn't find dust on my boards, workbench, glasses, or hair. I started out using the CT22 attached to my router to flush-trim MDF countertops, and was amazed when the vacuum gathered in even that superfine dust. Then I sanded 700 linear feet of trim for my house, and again no mess. The CT22 has an adjustable suction level, and I found the middle range best for sanding. The only drawback: I had to use adapters (not included) and duct tape to attach the hose to most of my non-Festool tools. It's the only vacuum in the test with a 20-amp plug, giving me more flexibility when used on a 20-amp circuit.



Capacity: 5.8 gallons
Hose: 1 1/4" x 11 1/2'
Tool Amps: 10; Noise Level: 72 dB

—Tested by Kevin Boyle, Senior Design Editor

To learn more:

888-337-8600; festoolusa.com

What's Ahead

A sneak peek inside the July issue (on sale May 13)



FEATURED PROJECT

Outdoor bar server

Enhance your outdoor living space with this low-cost, straightforward project. Its design matches the bistro table and stools featured in previous issues. You'll find all of the necessary supplies at your local home center.

TOOL TEST



Multi-base router kits

Routers with fixed and plunge bases give you great flexibility, as well as performance. We tested 12 kits to give you the lowdown on where to spend your bucks.



Our 20 best router tips and tricks

Work with greater accuracy and safety than ever before. You'll find techniques and jigs for everything from cutting dados to raising panels.



Knife handles and rack

Pair scraps of any fine wood with purchased knife blanks, shape the handles, then build this simple rack to hold your high-quality cutlery set.

Yo-yo

Figured wood, polished stone inlays, and a high-tech bearing insert transform this simple toy into a long-spinning treasure.



Safari puzzle

This jigsaw puzzle goes 3-D to create a changeable tabletop scene featuring a cast of characters from the African savanna.

BASIC-BUILT GREAT PROJECTS. SIMPLE TOOLS.

Mission end table

This easy-to-make project requires just a few hours in the shop, basic skills, and a modest assortment of tools.

