

Why **BUILD** furniture when the imported stuff is so **CHEAP?** (p.64)

Better Homes and Gardens®

ISSUE 184 JULY 2008

# WOOD

## 20 TOP ROUTER TRICKS AND TIPS p.46

**The Best Ways to Buy, Work, and Finish Oak** p.40

**Guaranteed Skill-Builders:**

- ◆ Rout Without Tear-out
- ◆ Secrets to Smooth Sanding

**Build this Simple Patio-perfect Bar** p.32



**Quick & Easy Project! Mission End Table** p.58

Display until July 15, 2008

0 7 >

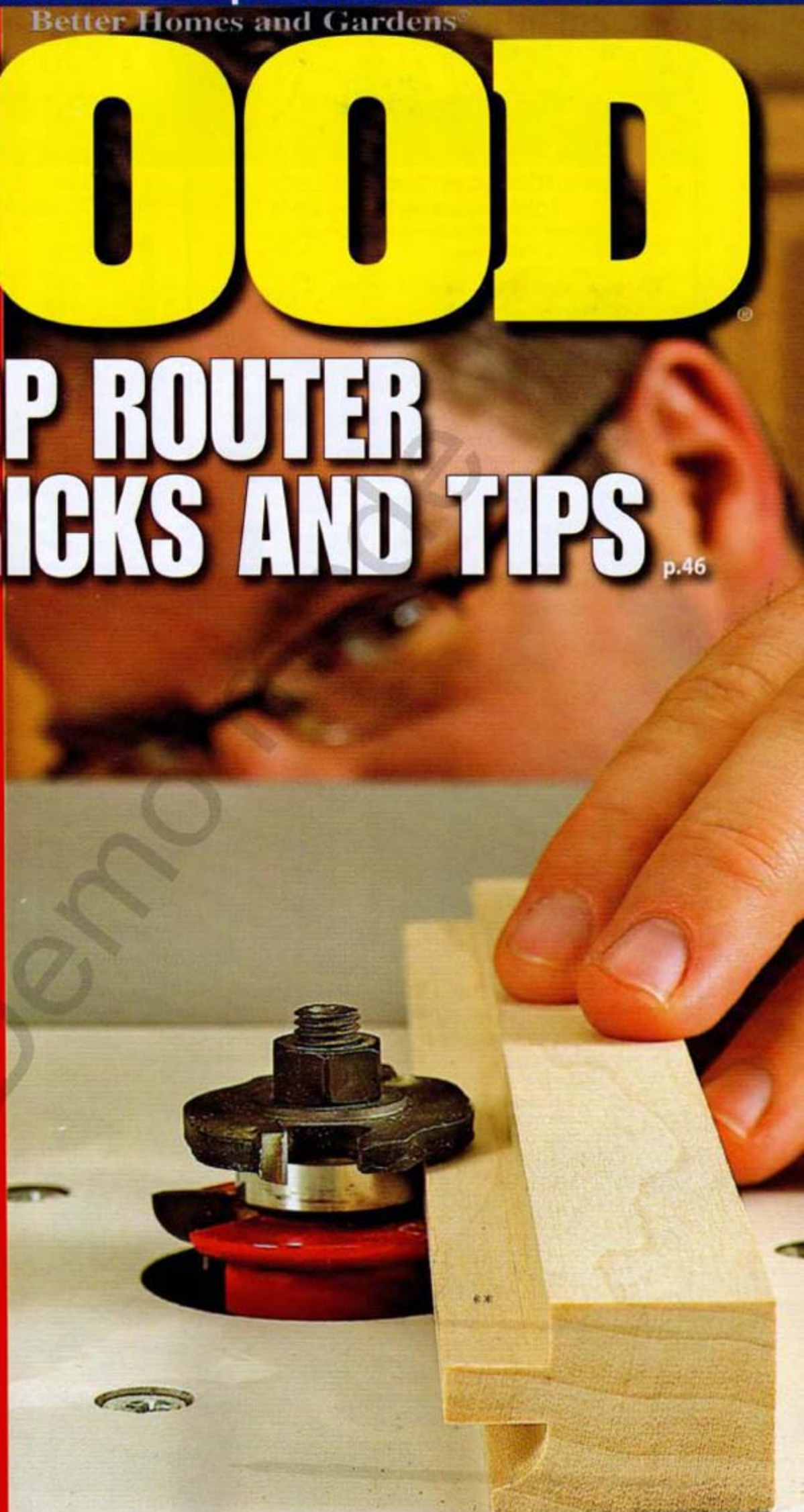



# Grizzly Industrial®

## Purveyors of Fine Machinery®

**New!**

### 10" Heavy-Duty Cabinet Table Saws w/Riving Knife

Perfect for cutting panels and wide stock!

- Motor: 3 HP, 220V, single-phase or 5 HP, 220V/440V\*, 3-phase
- Precision ground cast iron table
- Table size w/extension: 27" x 75 3/4"
- Max. depth of cut: 3 3/8" @ 90°, 2 1/4" @ 45°
- Arbor: 5/8"
- 52" rip capacity
- Approx. shipping weight: 514 lbs.

\*440V OPERATION REQUIRES PURCHASE OF ADDITIONAL COMPONENTS. CALL TECH. SERVICE FOR MORE INFO.



Riving Knife can be used with quick release guard!

**EXTREME SERIES**

Includes 10" Blade!

See it on Page 23 of the 2008 Catalog.

**\$159**

G0651 3 HP, single-phase

INTRODUCTORY PRICE **\$1695<sup>00</sup>**

G0652 5 HP, 3-phase

INTRODUCTORY PRICE **\$1695<sup>00</sup>**

**New!**

### Heavy-Duty 17" Extreme Bandsaw w/ Cast Iron Wheels

Only Grizzly offers these features for this price!

- Motor: 2 HP, 110V/220V, single-phase, TEFC
- Larger precision ground cast iron table size: 24" x 17"
- Table tilt: 5° left, 45° right
- Max. cutting height: 12"
- 2 blade speeds: 1700 & 3500 FPM
- Double ball bearing blade guides
- Quick change blade release/tensioner
- Approx. shipping weight: 414 lbs.

Cast Iron Wheels & Trunnion



MADE IN ISO 9001 FACTORY!

See it on Page 57 of the 2008 Catalog.

Includes Deluxe Re-saw Fence, Miter Gauge & 1/2" Blade

G0513X2

INTRODUCTORY PRICE **\$950<sup>00</sup>**

**\$89**

### 12" Baby Drum Sander

- Sanding motor: 1 1/2 HP, 110V, single-phase
- Conveyor motor: 1/10 HP, 110V, single-phase, variable speed 0-15 FPM
- Drum surface speed: 2300 FPM
- Max. stock dimensions: 12" wide x 3 1/2" thick
- Min. stock length: 8"
- Sanding drum size: 4"
- Sanding belt: 3" hook & loop
- Approx. shipping weight: 160 lbs.

SIDE HANDLES FOR PORTABILITY!

2 ADJUSTABLE PRESSURE ROLLERS & INDUSTRIAL-DUTY BELT



G0459

ONLY **\$650<sup>00</sup>**

**\$69**

### 10" Left-Tilting Table Saws w/Cast Iron Router Table

- Motor: 3 HP, 220V, single-phase or 5 HP, 220V, single-phase
- Precision ground cast iron table
- Table size w/wings attached: 27" x 48"
- Cutting capacity: 8" L, 26" R
- Approx. shipping weight: 500 lbs.

ROUTER AND WOOD NOT INCLUDED



G1023SLW 3 HP, single-phase ONLY **\$1050<sup>00</sup>**

G1023SLWX 5 HP, single-phase ONLY **\$1195<sup>00</sup>**

INCLUDES SHOP FOX CLASSIC™ FENCE

**\$159**

### 10" Left-Tilting Table Saw w/7" Rails & Extension Table

- Motor: 3 HP, 220V, single-phase
- Precision ground cast iron table
- Extension table size: 27" x 44"
- Arbor: 5/8" (accepts dado blades up to 1 3/16")
- Cutting capacity: 8" L, 54" R
- Max. depth of cut: 3" @ 90°, 2 1/8" @ 45°
- Approx. shipping weight: 532 lbs.

54" Cutting Capacity!

INCLUDES SHOP FOX CLASSIC™ FENCE & CAST IRON MITER GAUGE



WOOD MAGAZINE TOP VALUE APPROVED SHOP

G1023SLX ONLY **\$1295<sup>00</sup>**

**\$159**

### 19" Heavy-Duty Extreme Series® Bandsaw

- Motor: 3 HP, 220V, single-phase, TEFC
- Precision ground cast iron table
- Table size: 26 3/4" x 19" x 1 1/2"
- Cutting capacity/throat: 18 1/4"
- Max. cutting height: 12"
- Blade size: 143" L (1/8" - 1 1/4" wide)
- 2 Blade speeds: 1700, 3500 FPM
- Approx. shipping weight: 458 lbs.

Includes Aluminum Re-saw Fence Attachment, Dual Ball Bearing Blade Guides, Cast Iron Wheels & Fence

MADE IN ISO 9001 FACTORY!

**EXTREME SERIES**



G0514X

ONLY **\$1150<sup>00</sup>**

**\$89**

### 21" Super Heavy-Duty Bandsaws w/Tilting Geared Table

- Motor: 3 HP or 5 HP, 220V, single-phase
- Precision ground cast iron table
- Table size: 29 1/2" x 20 1/4" x 1 1/8"
- Table tilt: 5° L, 45° R
- Cutting capacity/throat: 20"
- Max. cutting height: 14"
- Blade size: 165" long (1/4" - 1 3/8")
- Blade speed: 4600 FPM
- Approx. shipping weight: 684 lbs.

Includes 1" Blade, Cast Iron Wheels & Fence



G0566 3 HP

ONLY **\$1850<sup>00</sup>**

G0531 5 HP

ONLY **\$1895<sup>00</sup>**

**\$169**

### Professional Spindle Shapers

- Motor: 5 HP, 220V, single-phase, TEFC or 7 1/2 HP, 220V/440V\*, 3-phase
- Precision ground cast iron table size: 35 1/2" x 28"
- Spindle sizes: 3/4", 1" & 1 1/4" x 7 1/2"
- Spindle speeds: 3600, 5100, 8000 & 10,000 RPM
- Spindle travel: 3 1/4"
- Max. cutter dia.: 5 1/8"
- Approx. shipping weight: 602 lbs.

5 HP, SINGLE-PHASE

G5912Z ONLY **\$2195<sup>00</sup>**

7 1/2 HP, 3-PHASE

G7214Z ONLY **\$2195<sup>00</sup>**

\*440V OPERATION REQUIRES PURCHASE OF ADDITIONAL COMPONENTS. CALL TECH. SERVICE FOR MORE INFO.



Includes Fence & Cast Iron Miter Gauge

**\$159**



MEDIA CODE WOODM0806A

Bill Me Later

# 1-800-523-4777

TECHNICAL SERVICE: 570-546-9663 FAX: 800-438-5901

3 GREAT SHOWROOMS!

BELLINGHAM, WA  
MUNCY, PA  
SPRINGFIELD, MO

Providing Quality & Service for 25 Years!

**BUY DIRECT  
& SAVE!**

- OVER A MILLION SQUARE FEET PACKED TO THE RAFTERS WITH MACHINERY & TOOLS
- 2 OVERSEAS QUALITY CONTROL OFFICES STAFFED WITH QUALIFIED GRIZZLY ENGINEERS
- HUGE PARTS FACILITY WITH OVER 1 MILLION PARTS IN STOCK AT ALL TIMES
- TRAINED SERVICE TECHNICIANS AT ALL 3 LOCATIONS
- MOST ORDERS SHIPPED THE SAME DAY • 24 HOUR ORDERING BY PHONE OR ONLINE

**IWFA** VISIT US AT  
**2008 BOOTH #5435**  
AUG. 20TH  
THROUGH  
AUG. 23RD

**New!** **15" Planer w/Spiral Cutterhead**  
An unbeatable combination of stability,  
power, smoothness & mobility!

- Motor: 3 HP, 220V, single-phase
- Precision ground cast iron tables & extension wings
- Table size: 15" x 20"
- Max. cutting height: 8"
- Feed rate: 16 & 30 FPM
- Cutterhead speed: 5000 RPM
- 2 speed gearbox
- Magnetic safety switch
- Heavy-duty cast iron construction
- Approx. shipping weight: 675 lbs.

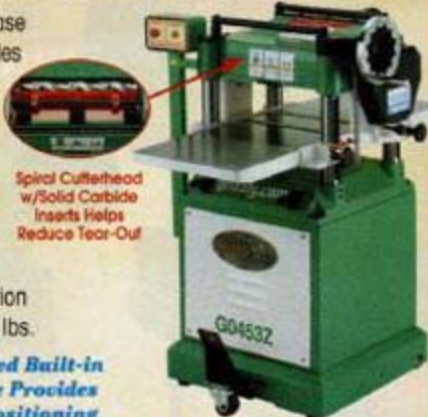

Spiral Cutterhead  
w/Solid Carbide  
Inserts Helps  
Reduce Tear-Out

Foot Operated Built-in  
Mobile Base Provides  
Versatile Positioning

**G0453Z**  
INTRODUCTORY PRICE **\$1295<sup>00</sup>**

**\$139**  
OFF

See it on Page 57  
of the 2008 Catalog.

**New!** **8" Jointer w/Spiral Cutterhead!**  
Versatile parallelogram  
table adjustment system!

- Motor: 3 HP, 220V, single-phase, TEFC
- Precision ground cast iron tables
- Total table size: 8" x 76 1/2"
- Infeed table size: 8" x 43 1/2"
- 4 row spiral cutterhead
- Cutterhead speed: 5350 RPM
- Max. rabbeting depth: 1/2"
- Deluxe cast iron fence size: 35"L x 1 1/4"W x 5"H
- Approx. shipping weight: 597 lbs.



MADE IN  
ISO 9001  
FACTORY!

Spiral  
Cutterhead

BUILT-IN  
MOBILE BASE

INCLUDES  
FREE SAFETY  
PUSH BLOCKS

**EXTREME  
SERIES**

**G0490X**  
INTRODUCTORY PRICE **\$1075<sup>00</sup>**

**\$139**  
OFF

Extra Long Infeed Table  
& Extra Tall Fence

See it on Page 41  
of the 2008 Catalog.

**20" Planer**

- Motor: 5 HP, 220V, single-phase
- Table size: 20" x 25 1/4" (20" x 55 1/2" w/ extension)
- Max. cutting width: 20"
- Max. cutting height: 8"
- Min. stock length: 7 1/2"
- Max. cutting depth: 1/8"
- Feed rate: 16 FPM & 20 FPM
- Cutterhead dia.: 3 1/2"
- Knives: 4 HSS
- Cutterhead speed: 5000 RPM
- Approx. shipping weight: 920 lbs.

Precision Ground  
Cast Iron Bed &  
Infeed/Outfeed  
Tables



BUILT-IN  
MOBILE BASE

**G0454 ONLY \$1295<sup>00</sup>**

**\$169**  
OFF

**20" Extreme Series® Planer  
w/Spiral Cutterhead**

- Motor: 5 HP, 220V, single-phase
- Precision ground cast iron table size: 20" x 25 1/4" (20" x 55 1/2" w/ extension)
- Max. depth of cut: 1/8"
- Max cutting height: 8 3/4"
- Cutterhead speed: 4800 RPM
- Feed rate: 16 & 20 FPM
- Approx. shipping weight: 909 lbs.



MADE IN  
ISO 9001  
FACTORY!

**G1033X ONLY \$2395<sup>00</sup>**

**\$169**  
OFF

**24" Professional Planers**

- Cutterhead motor: 5 HP, 220V, single-phase or 7 1/2 HP, 220V/440V\*, 3-phase
- Feed motor: 2 HP
- Precision ground cast iron table size: 24 1/2" x 31 1/2"
- Max. cutting depth: 1/8"
- Max cutting height: 8"
- Feed rate: 17-26 FPM
- Cutterhead speed: 5200 RPM
- Knives: 4 HSS
- Approx. shipping weight: 1130 lbs.

**EXTREME  
SERIES**  
Variable Feed Speeds  
& Lever Adjustable  
Feed Rollers



5 HP, SINGLE-PHASE  
7 1/2 HP, 220V/440V\*, 3-PHASE

**G5851Z ONLY \$3795<sup>00</sup>**

**G7213Z ONLY \$3795<sup>00</sup>**

**\$250**  
OFF

**12" x 83 1/2" Parallelogram Jointer**

- Motor: 3 HP, 220V, single-phase
- Precision ground cast iron table size: 12 3/4" x 83 1/2"
- Cutterhead knives: (4) 12" x 1/8" 1 1/4"
- Cutterhead dia.: 3 3/4"
- Cutterhead speed: 4950 RPM
- Max. depth of cut: 1/8"
- Max. rabbeting capacity: 3/4"
- Approx. shipping wt: 1036 lbs.

INCLUDES  
FREE SAFETY  
PUSH BLOCKS



Handles Fold  
In For Added  
Safety

**G0609**  
ONLY **\$1595<sup>00</sup>**

**\$250**  
OFF

**10" Extreme Series® Jointers**

- Motor: 3 HP, 220V, single-phase
- Precision ground cast iron table size: 11" x 84"
- Max. depth of cut: 1/8" • Rabbeting capacity: 1/2"
- Cutterhead speed: 5000 RPM
- Cutterhead dia.: 3 1/2"
- Approx. shipping weight: 977 lbs.

Built Like a  
Tank w/  
Heavy-Duty  
Cast Iron Base



4 BLADE CUTTERHEAD

**G0455 ONLY \$1695<sup>00</sup>**

SPIRAL CUTTERHEAD

**G0480 ONLY \$2095<sup>00</sup>**

**\$169**  
OFF

**The Ultimate 12" Extreme Series® Jointers**

- Motor: 3 HP, 220V, single-phase, TEFC
- Precision ground cast iron table size: 12 1/2" x 80"
- Center mounted fence: 4 3/4" x 39 1/4"
- Max. depth of cut: 5/16" • Bevel jointing: 90° - 45°
- Cutterhead dia.: 4"
- Cutterhead speed: 5900 RPM
- Approx. shipping weight: 1253 lbs.

INCLUDES FREE  
H2494 JOINTER PAL™  
KNIFE SETTING JIG



**EXTREME  
SERIES**

MADE IN ISO  
9001 FACTORY!

4 BLADE CUTTERHEAD  
**G9860 ONLY \$3150<sup>00</sup>**

SPIRAL CUTTERHEAD  
**G9860ZX ONLY \$4150<sup>00</sup>**

INCLUDES  
FREE SAFETY  
PUSH BLOCKS

**\$250**  
OFF



**grizzly.com**

OVER 12,000 PRODUCTS ONLINE!

FREE 2008  
CATALOG!  
700 FULL-COLOR PAGES  
OF HIGH QUALITY MACHINES,  
TOOLS & ACCESSORIES



# in this issue



32



70

## PROJECTS

- 26 Sheet-goods and scrap storage
- 32 Patio bar/server
- 44 Safari puzzle  
Kids will love this scrollsawn savanna scene.
- 58 Basic-Built: Mission end table
- 76 Turning project: Fun yo-yo
- 92 Shop-made knife handles  
Craft knives to match your kitchen.
- 94 Scrapwood Project: Knife rack

## TECHNIQUES

- 22 Troubleshoot poor tablesaw cuts
- 28 How to rout without tear-out
- 30 Best machine-mobility methods
- 46 **On the cover:** 20 top router tips
- 64 Feature: To buy or build furniture  
Why build when "made in China" is so cheap?
- 68 Hand-sand projects to perfection
- 86 Save yo... **SAVE YOUR HEARING!**

## TOOLS & MATERIALS

- 24 The best bits for box-bottom slots
- 40 How to buy, work, and finish oak
- 70 Tool test: Multibase router kits
- 80 6 ways to improve your shop vision
- 82 Tool test: Craftsman CompuCarve
- 90 Wise Buys: Hearing protection
- 100 Shop-Proven Products  
Sliding tablesaw table; sturdy stand; more

## DEPARTMENTS

- 8 Editor's Angle
- 10 Sounding Board
- 14 Shop Tips
- 96 Ask *WOOD*
- 108 What's Ahead



76



This seal is your assurance that we build every project, verify every fact, and test every reviewed tool in our workshop to guarantee your success and complete satisfaction.



92

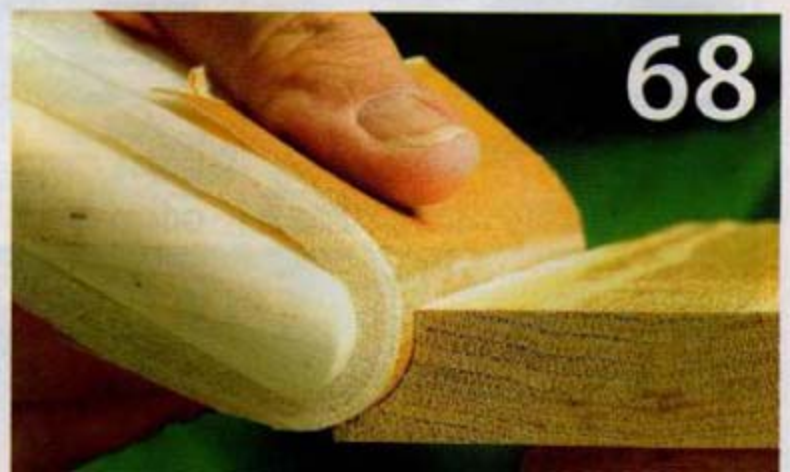

68

58



**BASIC-BUILT**  
GREAT PROJECTS. SIMPLE TOOLS.

86



40



# on the web

woodmagazine.com

## NASCAR, EAT YOUR HEART OUT

Joe Harmon's "Splinter" all-wood car could top 240 mph when completed this fall. Visit [woodmagazine.com/splinter](http://woodmagazine.com/splinter) to see Joe's live Webcam, daily blog, and photo gallery.



## ON-DEMAND VIDEO, ALL FOR FREE



It's just like **WOOD®** magazine—**in motion.** Woodworking skills come alive at [woodmagazine.com/videos](http://woodmagazine.com/videos). There you'll find more than 70 videos, and we won't charge you a cent to watch them.

## GREAT SHOP IDEAS BY THE DOZENS

Get inspired to organize and outfit your shop. Find the Internet's largest collection of shop photos, such as this efficient clamp-and-accessory rack posted by Robert Burgoyne of Peyton, Colorado, at [woodmagazine.com/shopshots](http://woodmagazine.com/shopshots).



## NOW IT'S YOUR TURN TO POST VIDEO

Share a Shop Tip or show off your shop! Grab the camcorder and a buddy and shoot video of your latest project-in-progress or a quick shop tour; then share it with the world. **WOOD** Multimedia Editor Lucas Peters explains how at [woodmagazine.com/lpblog](http://woodmagazine.com/lpblog).



# WHEN THE SAWDUST SETTLES...

## ZAR® finishes on top!

Whether you're creating your own masterpiece or want to give new life to a treasured family heirloom, only the best wood stain will do. ZAR Wood Stain's controlled penetration formula allows you to work at your own pace. ZAR Wood Stain wipes on easily and penetrates evenly for uniform color tone without streaks, lapmarks or blotches. So whether you're a professional or just want professional looking results - use ZAR Wood Stains and Clear Finishes.

**You control the stain,  
It doesn't control you!**



For a free brochure and the name of your nearest dealer call 1-800-272-3235, or visit us online at [ugl.com](http://ugl.com).

Circle No. 128

**UGL** UNITED GILSONITE LABORATORIES  
P.O. BOX 3122 WILMINGTON, DE 19806 • JACKSONVILLE, FL 32202 • WASHINGTON, DC 20004 • CHATTANOOGA, TN 37402

# Better Homes and Gardens® WOOD

woodmagazine.com

July 2008

Vol. 25, No. 3

Issue No. 184

EDITOR-IN-CHIEF  
BILL KRIER

Managing Editor **MARLEN KEMMET** Deputy Editor **DAVE CAMPBELL**

Art Director **KARL EHLERS** Senior Design Editor **KEVIN BOYLE**

Techniques Editor **BOB WILSON** Tool & Techniques Editor **BOB HUNTER**

Projects Editor  
**LARRY JOHNSTON**

Design Editor **JEFF MERTZ** Master Craftsman **CHUCK HEDLUND**



Jeff designed and built this full-size cherry Shaker bed.

Multimedia Editor **LUCAS PETERS** Associate Art Director **GREG SELLERS** Assistant Art Director **CHERYL A. CIBULA**

Production/Office Manager **MARGARET CLOSNER** Administrative Assistant **SHERYL MUNYON**

Photographers

**MARTY BALDWIN, JASON DONNELLY, DEAN SCHOEPPNER, JAY WILDE**

Contributing Illustrators **TIM CAHILL, LORNA JOHNSON, ROXANNE LeMOINE**

Technical Consultant **JEFF HALL**

Contributing Craftsman **JIM HEAVEY**

Contributing Proofreaders **BABS KLEIN, IRA LACHER, JIM SANDERS**

SUBSCRIBER SERVICE

Go to [woodmagazine.com/help](http://woodmagazine.com/help) or write to WOOD magazine, P.O. Box 37439, Boone, IA 50037-0439

Publisher **MARK L. HAGEN**

ADVERTISING AND MARKETING

**CHICAGO:** 333 N. Michigan Ave., Suite 1500, Chicago, IL 60601

Marketing Manager **AMANDA SALHOOT**

Advertising Managers **JACK CHRISTIANSEN, CAROLYN DAKIS**

Direct Response Advertising Representative **RYAN INTERLAND**

Assistants **GAYLE CHEJN, NIA WILLIAMS**

**ATLANTA:** Navigate Media

**DETROIT:** RPM Associates

Product Marketing Manager **DIANA WILLITS**

Business Manager **JEFF STILES**

Associate Consumer Marketing Director **DAN HOLLAND**

Associate Director of Marketing-Newsstand **TOM DEERING**

Senior Production Manager **MELANIE STOLTENBERG**

Advertising Operations Manager **JIM NELSON**

E-Commerce Manager **MATT SNYDER**

Vice President/Group Publisher **TOM DAVIS**

MEREDITH PUBLISHING GROUP

President **JACK GRIFFIN**

Executive Vice President **DOUG OLSON**

Editorial Director **MIKE LAFAVORE**

Finance & Administration **MIKE RIGGS**

Manufacturing **BRUCE HESTON**

Consumer Marketing **DAVID BALL**

Corporate Sales **JACK BAMBERGER**

Interactive Media **LAUREN WIENER**

Corporate Marketing **NANCY WEBER**

Research **BRITTA WARE**

Chief Technology Officer **TINA STEIL**

New Media Marketing Services **ANDY WILSON**

**Meredith**  
CORPORATION

President and Chief Executive Officer **STEPHEN M. LACY**

Chairman of the Board **WILLIAM T. KERR**

In Memoriam — E.T. Meredith III (1933–2003)

Our subscribers list is occasionally made available to carefully selected firms whose products may be of interest to you. If you prefer not to receive information from these companies by mail or by phone, please let us know. Send your request along with your mailing label to Magazine Customer Service, P.O. Box 37452, Des Moines, IA 50037-0452.

© Copyright Meredith Corporation 2008. All rights reserved. Printed in the U.S.A.

Retail Sales

Retailers can order copies of WOOD for resale by e-mailing [jennifer.buser@meredith.com](mailto:jennifer.buser@meredith.com)



Marlen incorporated eight wood species in this Southwest-style wall quilt.



Mark added wrought-iron touches to the tables he built from issue 172.



# INNOVATIVE PRODUCTS

**SHOP FOX®** is one of the fastest growing machinery lines in the country, offering an unbeatable combination of quality and affordability to all segments of the woodworking trade.



WOODSTOCK MACHINES AT IWF  
**BOOTH #5513**  
AUG. 20 - AUG. 23

We offer a 2 Year Warranty on all SHOP FOX® machines!

UNPARALLELED SERVICE HUGE SELECTION SUPERB QUALITY



## 19" HEAVY-DUTY BANDSAW

MADE IN AN ISO 9001 FACTORY!



- ▶ 2 HP, 110V/220V, single-phase, TEFC motor
- ▶ 19" x 26<sup>3</sup>/<sub>4</sub>" precision ground cast iron table
- ▶ Table tilt: 10° L, 45° R
- ▶ 2 blade speeds: 1700 & 3500 FPM
- ▶ Cutting height: 12"
- ▶ Cast iron wheels
- ▶ Quick release blade tensioning

Includes 3/8" blade, fence and miter gauge

**W1729**



## 15" OPEN END WIDE-BELT SANDER

Includes pull out support bar



- ▶ 5 HP, 220V, single-phase, 1725 RPM sanding motor
- ▶ 1/4 HP feed motor
- ▶ Sanding capacity: 30"
- ▶ Belt speed: 2050 FPM
- ▶ Belt size: 16" x 48"
- ▶ Feed rates: 13 & 16 FPM
- ▶ Pneumatic belt tracking, tensioning & oscillation
- ▶ Adjustable platen

Built-in regulator & filter and amp load meter

**W1689** MADE IN AN ISO 9001 FACTORY!

## 8" JOINTER

w/Parallelogram Adjustable Beds

- ▶ 3 HP, 220V, single-phase, TEFC motor
- ▶ Precision ground cast iron parallelogram design table measures 8" x 76<sup>3</sup>/<sub>4</sub>"
- ▶ 4 knife, 5350 RPM cutterhead
- ▶ Rabbeting capacity: 5/8"
- ▶ Quick adjust levers
- ▶ Large center mounted cast iron fence

Internal Magnetic Safety Switch w/Thermal Protection



**W1741**

Built-in Mobile Base

## 2 1/2 HP SHAPER

- ▶ 2 1/2 HP, 220V, single-phase motor
- ▶ Precision ground cast iron table measures 28" x 30"
- ▶ Spindle travel: 3"
- ▶ 2 spindle speeds: 7000 & 10,000 RPM
- ▶ Includes 1/2" & 3/4" spindles and 1/4" & 1/2" router bit collets
- ▶ Convenient pedestal controls

Split adjustment fence & fully adjustable cutter guard

**W1763**

Built-in Mobile Base



## 1 HP POWER FEEDER



- ▶ 1 HP, 220V motor
- ▶ 4 feed speeds: 13, 26, 33 & 66 FPM
- ▶ Vert. movement: 9"
- ▶ Horiz. movement: 17"
- ▶ Max. roller height: 7"
- ▶ Forward & reverse rotation

**W1767**

MADE IN AN ISO 9001 FACTORY!

## 1 HP POWER FEEDER w/4 Rollers

- ▶ 1 HP, 220V, single-phase motor
- ▶ 4 feed speeds: 13, 26, 36 & 72 FPM
- ▶ Vert. movement: 9 1/2"
- ▶ Horiz. movement: 24 1/4"

**W1768**

MADE IN AN ISO 9001 FACTORY!

## 20" PLANER w/Spiral Cutterhead

- ▶ 5 HP, 220V, single-phase, TEFC motor
- ▶ Precision ground cast iron table measures 20" x 25 1/4"
- ▶ 2 feed speeds: 18 & 23 FPM
- ▶ 4 row spiral cutterhead w/carbide inserts
- ▶ Cutterhead speed: 5500 RPM
- ▶ Heavy-duty cast iron construction

MADE IN AN ISO 9001 FACTORY!

Magnetic Safety Switch w/Thermal Overload Protection

**W1718**



## HEAVY-DUTY MORTISING MACHINE w/Stand



- ▶ 1 1/2 HP, 110V/220V, single-phase, TEFC motor
- ▶ Table size: 19" x 12 1/2"
- ▶ Head tilts ±30°
- ▶ X & Y table movement
- ▶ Chisel capacity: 1/4" - 1"
- ▶ Accepts 3/8" & 3/4" collars
- ▶ Solid cast iron construction

Steel Cabinet Stand w/Indexed Storage Shelf for Mortising Chisels

**W1743**

## 37" DUAL DRUM SANDERS

- ▶ 10 HP, 220V, single-phase or 15 HP, 220V/440V\*, 3-phase sanding drum motor
- ▶ 1/4 HP conveyor motor
- ▶ Drum diameter: 6"
- ▶ Industrial rubber conveyor belt
- ▶ Variable conveyor feed rate: 6 - 18 FPM
- ▶ Control panel with amp load meter
- ▶ Max. stock dimensions: 36 1/2" wide x 4" thick

State-of-the-art Computer Balanced Dual Drums

10 HP, Single-Phase

**W1772**

15 HP, 3-Phase

**W1773**



## 3 HP CYCLONE DUST COLLECTOR

- ▶ 3 HP, 220V, single-phase, TEFC Class "F" motor
- ▶ 8" intake hole
- ▶ 0.2 - 2 micron filters
- ▶ Magnetic switch w/remote control
- ▶ Noise reducing mufflers
- ▶ 55 gal. steel collection drum w/casters

Includes steel stand & detailed instruction manual

**W1809**



SHOP FOX® is a registered trademark of Woodstock International, Inc.



VISIT OUR WEBSITE OR CALL TOLL FREE TO FIND AN AUTHORIZED DEALER NEAR YOU.

**SHOPFOX.BIZ 1-800-840-8420**

sales@shopfox.biz

WHOLESALE ONLY

10376R



## TEST LESS.

Save time with 4200 series jigs from PORTER-CABLE.<sup>®</sup> Each comes with a single-piece steel base that attaches directly to your workbench. Other timesaving features include clear onboard instructions, board alignment lines, template adjustment knobs and router bit depth gauges. Choose from three models, each offering a different level of versatility. It all adds up to quick setups, easy adjustments and fewer test cuts. One more example of how we don't just pay attention to the details. We obsess over them.



Board alignment lines



Router bit depth gauge



Single-hand clamping

**PORTER  CABLE.**

The Measure of Precision





# MAKE MORE.

Now you can cut hundreds of joints with just one jig. The new OMNIJIG® comes preassembled and calibrated right out of the box. Color-coded onboard instructions ensure it's also easy to use. Router bit depth gauges and template-positioning stops combine to offer repeatability across applications. Add innovative details like a router stabilizer bar and variable-spaced fingers and no other jig even comes close. To check out our instructional video featuring Norm Abram, visit [deltaportercable.com/jigs](http://deltaportercable.com/jigs).



Variable-spaced fingers  
Model 77240



Router bit depth gauges



Router stabilizer bar

**PORTER  CABLE.**

The Measure of Precision

## Ultimate bragging rights: Your workshop in a national magazine!

Do you have the kind of shop other woodworkers like to visit? Is your shop filled with clever ideas that help you work smarter, faster, or safer? If so, submit your workshop for publication in **America's Best Home Workshops, Volume 3** (Volume 2, on sale at newsstands on 5/27/08, is shown above).



### We're looking for shop projects, too

In addition to entire shops, we are also looking for unique individual shop organizers, workbenches, tool holders, clamp racks, lumber supports, and other projects that make your shop special.

To be considered, send us your materials by 7/1/07

### What to send us:

- 3 to 5 photos showing the overall interior layout of your shop and 1 exterior photo, if applicable
- 5 to 10 close-ups of your problem-solving ideas, or dedicated machining or storage areas
- A rough-sketch floor plan that shows overall shop dimensions and the locations of doors and windows, tools, storage cabinets, workbenches, and wood storage
- A short paragraph about why your shop is great and how it serves your woodworking interests



Mail your submission to:

### America's Best Home Workshops

WOOD magazine

1716 Locust St., LS-221

Des Moines, IA 50309-3023

Or e-mail your submission to

[homeworkshops@meredith.com](mailto:homeworkshops@meredith.com)

Submissions cannot be returned, but please include your name, address, telephone number, and e-mail address if available.

## Editor's Angle

# Router Mania

A lot of us are just nuts about routers. No wonder: You won't find a handier, more versatile tool. Of course, to get the most from a router, you need to (1) own one that won't let you down and (2) know a few tricks for using it effectively. This issue helps you on both counts.

It wasn't a hard decision to devote 14-plus pages in this issue to router-related articles. The reason: We live in a router-crazy woodworking world. Consider the following:

- For what other tool can you spend five times as much on accessories as on the actual tool? There are a lot of \$200 routers mounted in \$1,000 router tables.
- Several companies focus their business on router accessories. For example, the Woodhaven catalog ([woodhaven.com](http://woodhaven.com)) is a router junkie's dream come true. Of the hundreds of products spread over 48 pages, nearly half are router-related.
- We have more routers (nine!) than any other power tool in the WOOD® Magazine Shop. In fact, I've heard our staffers joke that it sure would be nice to have a router for each of the dozens of bits in the shop.

Short of driving fasteners and sanding, there are few shop tasks a router can't perform. If you use one just for shaping edge profiles, you're only scraping the surface of what it can do. Have you used a router to cut along a template; joint an edge; or cut mortises, dovetails, and other joints? You can do these tasks—and many others—with results you'd be hard-pressed to match using other tools.

No matter your personal level of router madness, in this issue you'll find several articles to enjoy:

- On page 70, Tool Editor Bob Hunter reviews a dozen multibase router kits.

These combo units have become increasingly popular as woodworkers realize the cost savings of interchanging one motor between plunge and fixed bases. Like a reality-TV show, Bob votes routers "off the island" until he arrives at his choices for our coveted Top Tool and Top Value designations.

He also made a critical improvement to the model-by-model comparison chart at the end of the article. Now, you'll find the performance grades ranked as "primary" or "secondary," according to their relative importance. Since an "A" in "power" is more important than an "A" in "depth scale readability," the chart now reflects that.

- On page 28, Bob takes on one of the most vexing problems known to router-kind: grain tear-out. He and Master Craftsman Chuck Hedlund come through with several simple solutions.
- We challenged the other Bob on our staff, Techniques Editor Bob Wilson, to find the 20 best router tips and tricks of all time (there are hundreds; trust me), and Bob W. delivers on page 46. Got to admit, after 35 years in woodworking, I learned a thing or two myself.

Happy routing,

*Bill Krier*



EXPERIENCE TOTAL CONTROL.



### INTRODUCING NEW VARATHANE FOAM STAIN

A revolutionary concept in wood staining that gives you maximum consistency, stability and control like never before. Varathane Foam Stain makes your project hassle free by eliminating the mess of drips and runs — even on vertical surfaces. Consistent coverage is easy. Foam on. Rub in. No mess. Plan your next project at [woodanswers.com](http://woodanswers.com)

INNOVATIVE      UNEXPECTED      REVOLUTIONARY

*Varathane*  
— SINCE 1988 —  
WOOD'S FIRST CHOICE®

# Sounding Board

Our bulletin board for letters, comments, and timely updates

## This just in: Six more quarters on the way!

In 2009, the United States Mint will add six new coins to its 50 State Quarters Program to honor the District of Columbia and five U.S. territories. Following the D.C. quarter, in order, will be Puerto Rico, Guam, American Samoa, the U.S. Virgin Islands, and the Northern Mariana Islands.

To accommodate this change—no pun intended—we've updated the State Quarters Map project in *WOOD*® magazine issue 131 (March 2001) and also available online at [woodmagazine.com/quartermap](http://woodmagazine.com/quartermap). We're adding six two-coin holders—for coins from both mints—that can be placed off the Atlantic coast of Florida, as shown at right. If you top-coated your map with a film-forming clear finish, such as lacquer or polyurethane, use quick-set epoxy to adhere the

new holders to the map. To get a brass plaque that identifies the new coins, send \$5 and a self-addressed, stamped, business-size envelope to WOOD Territory Plaque, 1716 Locust St., LS-221, Des Moines, IA 50309-3023.

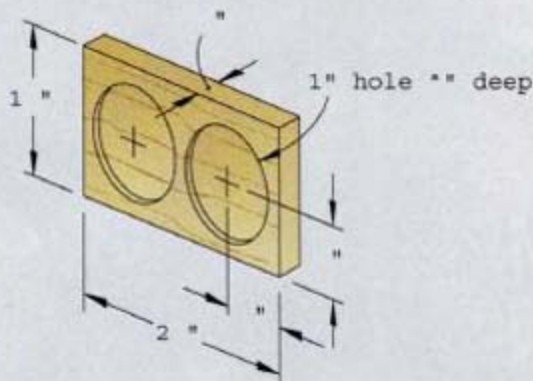

## There are better options than lanyards for pencils

As a former high-school woodshop teacher, I propose a safer alternative to the breakaway pencil-on-a-lanyard tip in the Shop Tips section of issue 179 (October 2007). I always enforced a rule prohibiting students from using machinery while wearing long sleeves or dangly jewelry, and I'm skeptical of the lanyard breaking away every time. It's just not worth the risk. Instead, I recommend gluing small magnets onto pencils and then attaching them to out-of-the-way locations on every

machine in the shop. That way, there's always a pencil at the ready.

—Bill Kirchner, Yucca Valley, Calif.

Bill's letter was one of several we received voicing concern about the safety of the Shop Tip. In hindsight, we have to agree there could still be potential for danger. Bottom line: It's probably best to avoid using a lanyard. Never shortcut safe workshop habits.

—WOOD® Editors

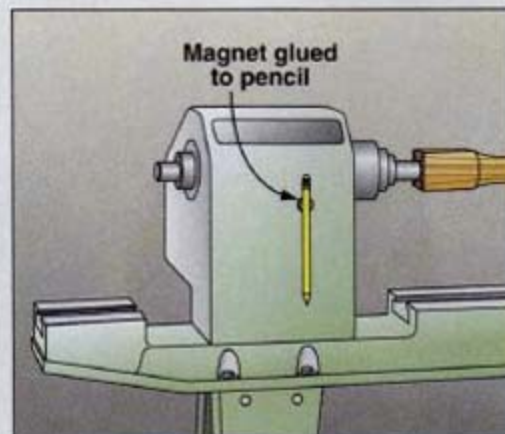

## HOW TO REACH US

### ■ For woodworking advice:

Post your woodworking questions (joinery, finishing, tools, turning, general woodworking, etc.) on one of 16 online forums at [woodmagazine.com/forums](http://woodmagazine.com/forums).

### ■ To contact our editors:

Send your comments via e-mail to [woodmail@woodmagazine.com](mailto:woodmail@woodmagazine.com); or write to *WOOD* magazine, 1716 Locust St., LS-221, Des Moines, IA 50309.

### ■ Subscription assistance:

To notify us of an address change or to get help with your subscription, visit [woodmagazine.com/service](http://woodmagazine.com/service). Or write to *WOOD* magazine, P.O. Box 37439, Boone, IA 50037-0439. Please enclose your address label from a recent magazine issue.

### ■ To find past articles:

See our index at [woodmagazine.com/index](http://woodmagazine.com/index).

### ■ To order past issues and articles:

Order past issues of *WOOD* magazine, our special issues, or downloadable articles from issue 100 to present: Visit our online store at [woodmagazine.com/store](http://woodmagazine.com/store). Some issues are sold out.

### ■ Updates to previously published projects:

For an up-to-date listing of changes in dimensions and buying-guide sources from issue 1 through today, go to [woodmagazine.com/editorial](http://woodmagazine.com/editorial).

**What's The Secret To Flawless Edge Profiles With NO REWORK?**

# Quadra-Cut™



38-106

## Freud's New Quadra-Cut™ 4 Cutter Design



### How It Works!

Two large cutter wings shear upward to remove most of the stock for fast, extremely smooth cuts.

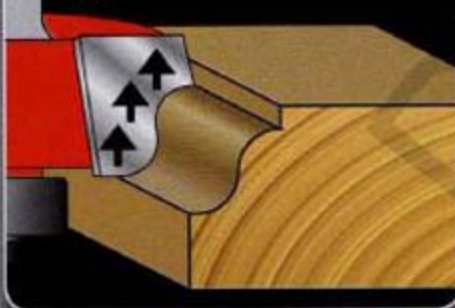

Two small cutter wings shear downward for an ultra-fine finish, even when routing crossgrain in delicate materials!

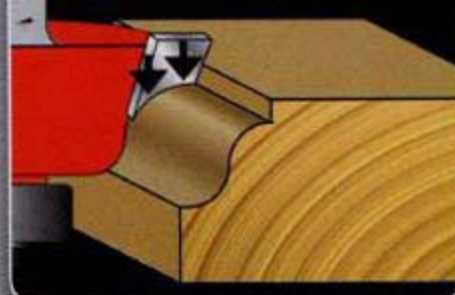

U.S. Patent No. 8,899,252

**For A Smooth Sanded Finish...**

**...Without The Rework!**

Freud's Exclusive 4 Cutter Design



All Other Router Bit 2 Cutter Design



**"Mirror-smooth finish with sharp, clean details!"**

- Chris Marshall, *Woodworker's Journal*

**"Super-smooth cuts!"**

- Glen Huey, *Popular Woodworking*

#### Look For These Popular Profiles in 1/2" Shank Quadra-Cut™ Design:

- Classical Cove & Round Bit
- Rounding Over Bit, 3/8" Radius
- Rounding Over Bit, 1/2" Radius
- Rounding Over Bit, 1" Radius
- Beading Bit, 5/16" Radius
- Beading Bit, 1-1/8" Radius
- Table Top Classical Bold Bit
- Table Edge Bit
- Rounding Over Bit, 5/8" Radius
- Rounding Over Bit, 1-1/2" Radius
- Raised Panel Bits



**freud®**  
Precisely the best

To sign up for Freud's e-mail newsletter or to find a dealer near you visit: [www.freudtools.com](http://www.freudtools.com)  
Red router bits are a registered trademark of Freud America, Inc. (US) 7-800-472-7307



50-720CT  
with canister

DELTA

# COLLECT DUST ONCE.

Eliminate the dust that gets back into the air when emptying a reusable bag. The new DELTA 50-720 and 50-720CT dust collectors feature specially designed disposable bottom bags. Plus a 1-micron filtration rate on model 50-720 captures even the finest dust. Besides generating a powerful 650 cubic feet per minute, you'll appreciate the compact industrial design featuring solid cabinet housing and large swivel casters. So checkout the new DELTA dust collectors at [deltaportercable.com/dustcollection](http://deltaportercable.com/dustcollection). Because when precision is at stake, we don't just pay attention to the details of dust collection. We obsess over them.



50-720



mess free  
fill & toss bags



best in class filtration  
for cleaner shop

 **DELTA**

The Measure of Precision™

# Shop Tips

Helping you work faster, smarter, and safer

## Miters at full-tilt speeds with no-tilt blade

When I found myself making a lot of memorial flag cases, I needed a method to cut 45° miters quickly and accurately in wide stock. The sled I came up with lets me make miters in no time at all without even tilting my saw blade. And, it does it without causing tear-out on the workpiece.

After cutting the sled base slightly oversize, tilt your blade to 45° to cut the bevel on the sled base. Then, with the blade returned to the 90° position, insert the miter-slot guide into your tablesaw's miter slot, position the sled base against the blade body to ensure that it is square, then, fasten the base to the miter-slot guide. Using the bevel of the sled base as a guide, mount the 45° wedges in place.

Cut a groove in the oversize top plate and mount the T-track and T-track

screw cleat, as shown. The cleat provides holding power for the T-track screws. Attach the fence to the top plate, ensuring that it is square by using the slots in the top plate for adjustment. Then, attach the top plate to the wedges, sliding it down until the edge touches the tablesaw table. With the blade still set to 90°, cut off the excess.

Finally, assemble and attach the hold-down that will secure the workpiece against the fence and keep it from slipping toward the blade.

Besides extremely accurate miter cuts, the sled has an added benefit. Simply turn the workpiece over and adjust the blade height, and the sled can be used to cut the slots for a splined miter joint.

—Joy Wood, Winchester, Ill.

## Top Shop Tip

## The Top Tipster



Photo: Charles Reed Photography

Retired Air Force Colonel Joy Wood plays a big role in performing military burial rites along with other veterans from her VFW post. Besides serving as chaplain and bugler, she builds flag cases to be presented to the families. With that kind of busy schedule, she needed a fast, accurate, no-nonsense way to cut the case bevels, and so was born the Top Shop Tip at left.



Joy, we salute the work that you are doing and are proud to present you with a Grizzly G0555 14" band-saw for sending in this issue's Top Shop Tip.

## Top tips earn tools!

Tell us how you've solved a workshop stumper. If we print it, you'll get \$100 and a copy of 450+ Best-Ever Shop Tips ([woodmagazine.com/450tips](http://woodmagazine.com/450tips)). And, if your idea garners Top Shop Tip honors, we'll also reward you with a tool prize worth at least \$300.

Send your best ideas, along with photos or drawings and your daytime phone number, to: **Shop Tips, WOOD Magazine, 1716 Locust St., LS-221, Des Moines, IA 50309-3023.** Or, by e-mail: [shoptips@woodmagazine.com](mailto:shoptips@woodmagazine.com). Include your contact info in the e-mail.

Because we try to publish original tips, please send your tips only to WOOD® magazine. Sorry, submitted materials can't be returned.



continued on page 16

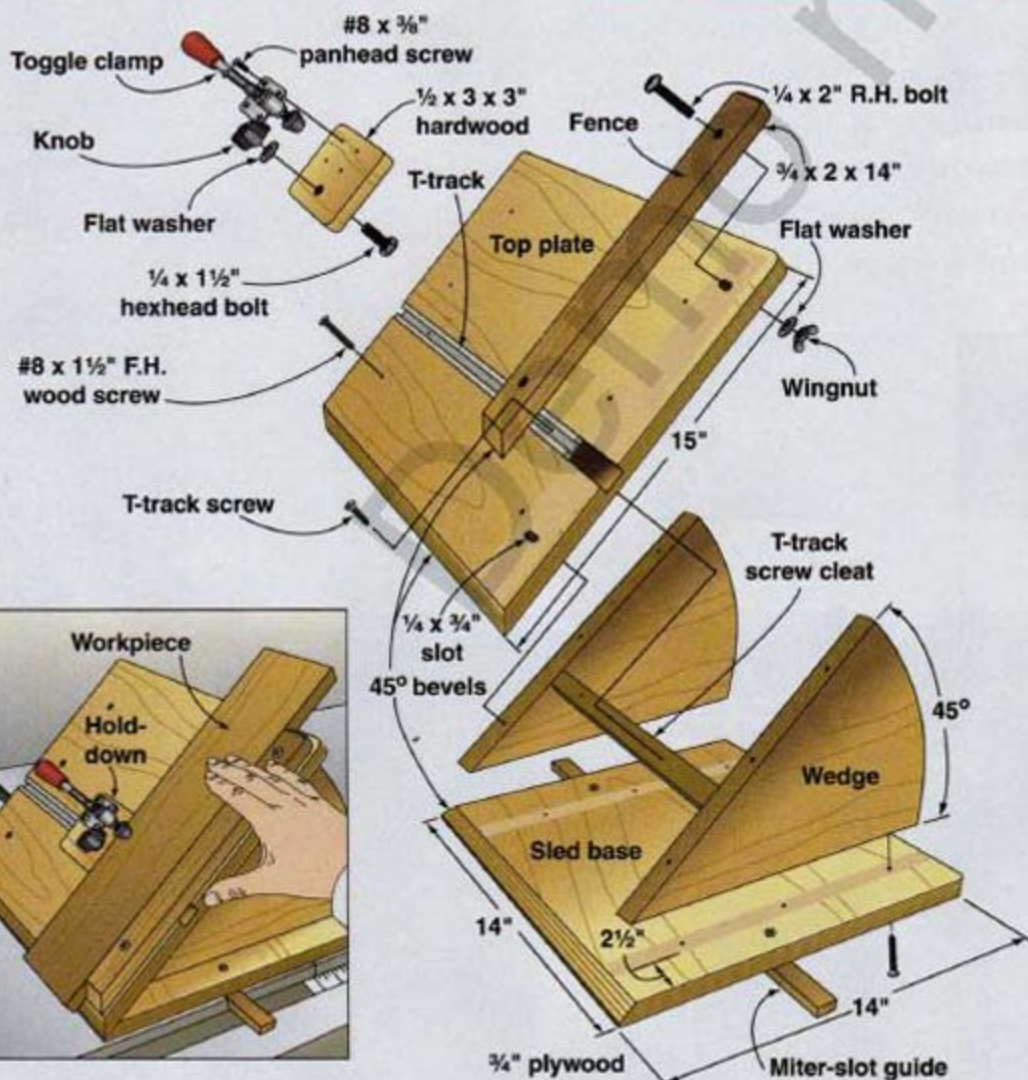



# TODAY I DISCOVERED NEW GORILLA WOOD GLUE

IS TOUGH ENOUGH FOR EVERY WOODWORKING JOB  
AND THAT A PERFECT DOVETAIL JOINT CAN MAKE A GROWN MAN CRY

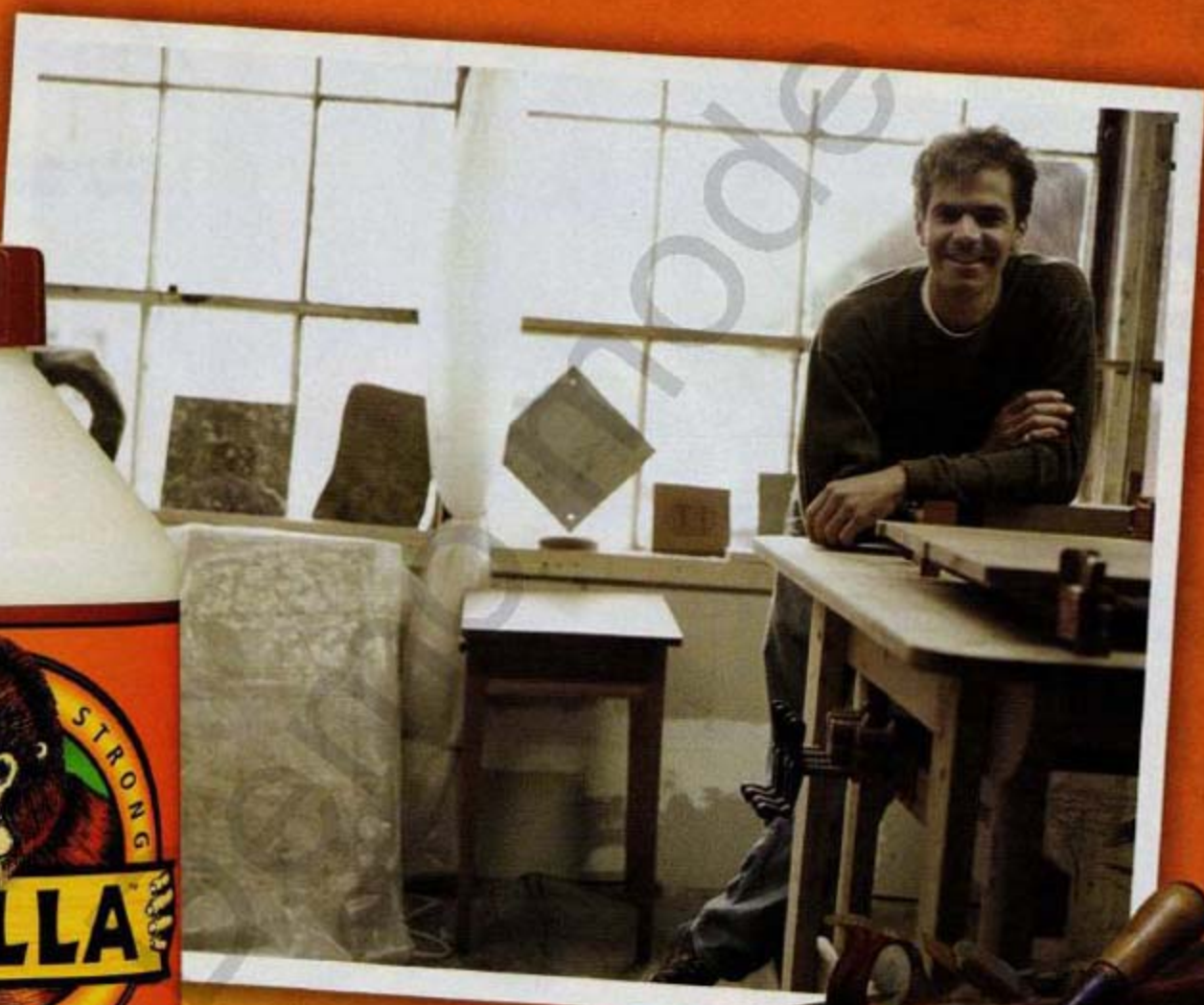

FOR THE TOUGHEST JOBS  
ON PLANET EARTH.™

1-800-966-3458 • GORILLATOUGH.COM

## Free up floor space with fold-down stock supports

When I revamped my shop, I wanted to put my miter saw where it wouldn't take up space on my bench but would still be handy. So I built the simple wall-mounted miter-saw station shown. It freed my benchtop and makes it easier to sweep up my shop.

What I gained in benchtop space, though, I lost in workpiece support. My solution: folding 12" shelf brackets (\$15 each, item #128944 from Woodcraft, 800-225-1153 or woodcraft.com). It takes only seconds to lock them in place or fold them out of the way. I added a 1x4 board to the top of each bracket and then mounted them so they match the height of my miter saw's table.

—Fred Hand, Payette, Idaho

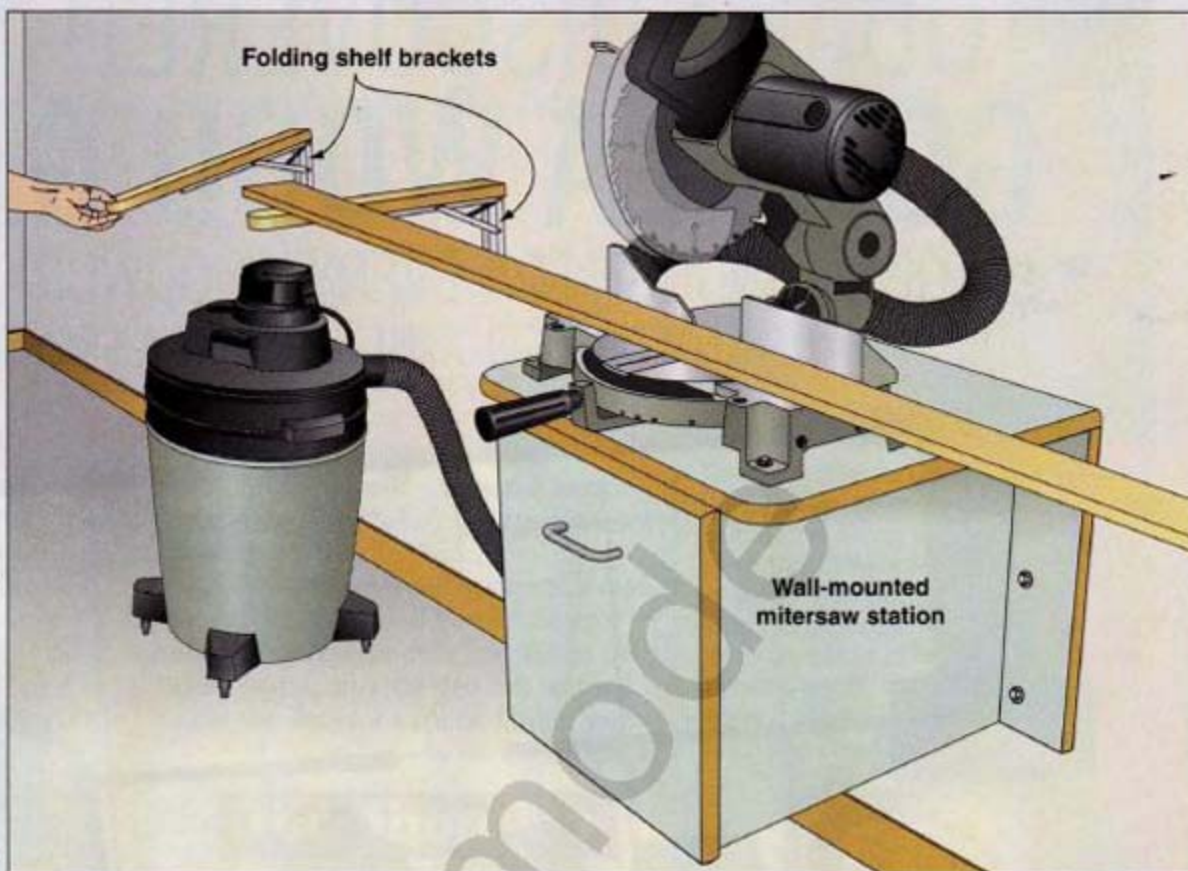

## Quick-set gauge for honing guide

To keep my hand planes and chisels razor-sharp, I like to use a wheeled honing guide. It works great, but I wanted a way to quickly square the blade in the guide and to set the correct blade extension for the bevel angle. The result is the acrylic angle-setting jig shown at right.

Make the jig body from a 5x7" piece of 1/4" acrylic. On the bottom of the jig, use cyanoacrylate glue to adhere the cleat shown. You press the cleat firmly against the edge of your bench during use. Next, glue the squaring fence as shown, perfectly square to the front edge of the jig body.

Now, set the blade in your honing guide as you normally would. Then, hold the honing guide against the near end of the jig, lay the blade down on the angle-setting jig, and score a line in the acrylic using a utility knife. For better visibility, I colored the line with a permanent marker, immediately wiping off the excess ink.

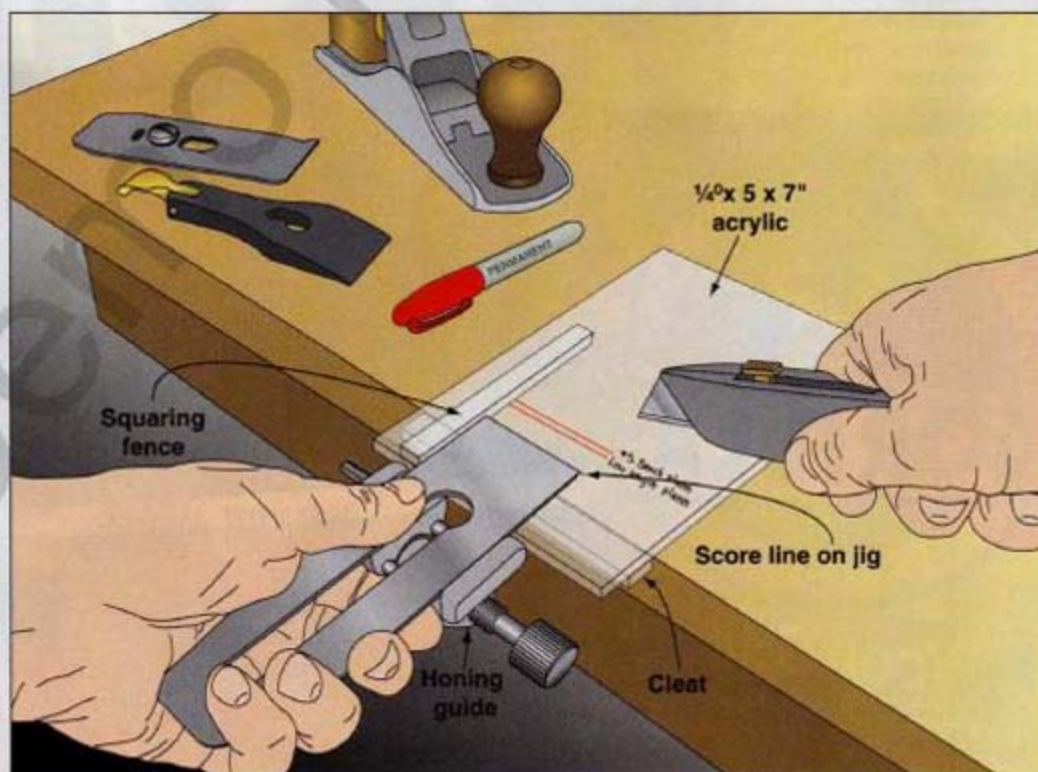

You can score and label multiple lines on your jig for different plane irons, chisels, and the like, but these angle-setting jigs are easy enough to make that you can make one for each tool or grinding angle.

Next time you need to sharpen this blade, just lay the blade against the fence, hold the beveled end on the scored line, and mount your honing guide, holding it against the jig.

—Willard Anderson, Chapel Hill, N. C.

continued on page 18



Building a deck is hard.

Recycling the rechargeable battery  
inside your drill is easy!

When the rechargeable batteries in your cordless products no longer hold a charge, recycle them! There are 40,000 nationwide *Call2Recycle*™ collection sites in stores you visit every week! It's free. It's convenient. *It's that easy.*

**call2recycle™**

A Rechargeable Battery Recycling Corporation program

[call2recycle.org](http://call2recycle.org)

Recycle the used rechargeable batteries in your cordless power tools, camcorders, laptop computers, cordless and cellular phones, digital cameras, and two-way radios at one of these national retailers.

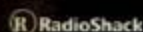

# More Power for Your Workshop

Use it once and it will become your favorite woodworking tool!

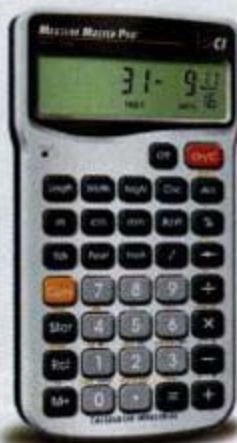

## MEASURE MASTER<sup>®</sup> PRO

**Feet-Inch-Fraction and Metric Dimension Calculator**

You'll get professional woodworking results with ease. The Measure Master makes it simple to work in, and convert between, most common dimensional formats – as well as Areas and Volumes. Includes built-in Board-Foot solutions.

Model 4020

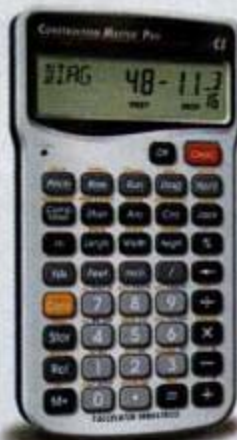

## CONSTRUCTION MASTER<sup>®</sup> PRO

**Advanced Feet-Inch-Fraction Construction-Math Calculator**

Our most complete calculator for the advanced woodworker. It features more powerful built-in solutions, in addition to those found in the Measure Master Pro. The perfect tool if your woodworking passion includes projects such as remodeling or adding a room. It even provides Angles for compound miters.

Model 4065

## HOME PROJECTCALC<sup>®</sup>

**Do-It-Yourself Project Calculator**

Simplify your home improvement projects with this easy-to-use calculator. Built-in function keys let you quickly and accurately find material requirements for paint, concrete, tiles, wallpaper and carpet. Model 8510



For the dealer nearest you, call today  
1-800-854-8075 or visit...

[www.calculated.com](http://www.calculated.com)



**CALCULATED INDUSTRIES<sup>®</sup>**

4840 Hytech Drive Carson City, NV 89706  
1-775-885-4900 • Fax: 1-775-885-4949

WD-608

## Shop Tips

### Sturdy stand stores spinning sanders

I normally use two orbital sanders at a time, each with a different grit. The stand shown here has custom-size cutouts to hang my sanders while still spinning. I clamp the stand to a bench, as shown, to hold it securely.

When not in use, the sanders store nicely in the stand. A handle makes it easy to carry, and a locking dowel keeps the sanders in place in transit. My 14"-wide and 7"-deep stand will accommodate most 5" random-orbit sanders, but your stand's height will depend on your sanders.

—John Monroe, Greensfork, Ind.

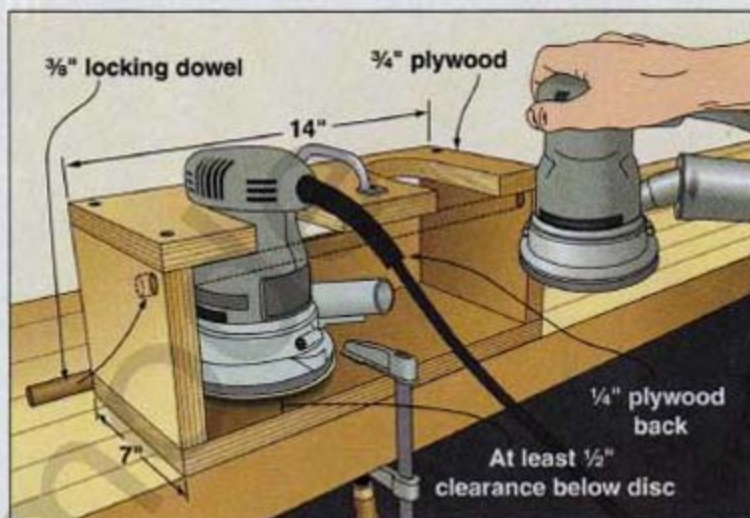

### Router house defeats dust problems

After mounting my router in the extension of my table saw, I needed a dust-collection solution that allows easy access to the router for bit-height adjustments. The box shown here encapsulates the router and allows the dust collector to create the necessary vacuum pressure to work well. I used a 3" O.D. (outside dia.) PVC toilet flange to create the dust-collection connection. A hinge secures one end of the housing, and a set of hooks and eyes holds the box open for router access or closed for operation.

—Steve Conway, Oakdale, Minn.

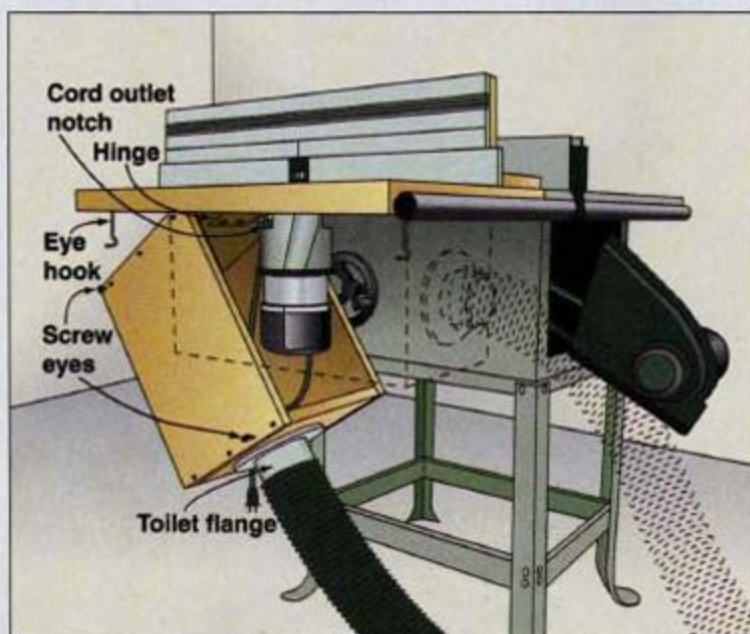

continued on page 20

The **WOOD**® Store

# Super Savings Event

**HURRY! SALE ENDS MAY 31**

Go to [woodmagazine.com/woodstore](http://woodmagazine.com/woodstore) for these special offers NOW!



**50% OFF**

**Selected Plans & Magazine Packs!**

2005 WOOD  
Issues on CD  
Save \$5



Plus!  
**FREE Tips Book**  
with Purchase



**25% off on ALL  
Outdoor Project Plans!!!**



**Buy any 2 Back Issues — Get the 3rd FREE!!!**



**Special WOOD book offer — buy 2 & Save \$9.95**

## Shop Tips

### Surefire centerline for spindles

There are a few occasions, such as during chair or crib construction, when you need to drill multiple holes in a spindle and the holes need to be in a straight line with each other. The best way I've found to keep them in line is with a carefully placed and snapped chalk line.

To prevent chalk dust from fouling open-grained wood, I first cover, with masking tape, the spindle area to be marked. Then, I tap a small finish nail into the holes left by the lathe centers on each end of the spindle, carefully string the chalk line between the nails, making sure the string comes off the same side of each nail, and snap the line.

—Dick Benedetti, Lake Oswego, Ore.

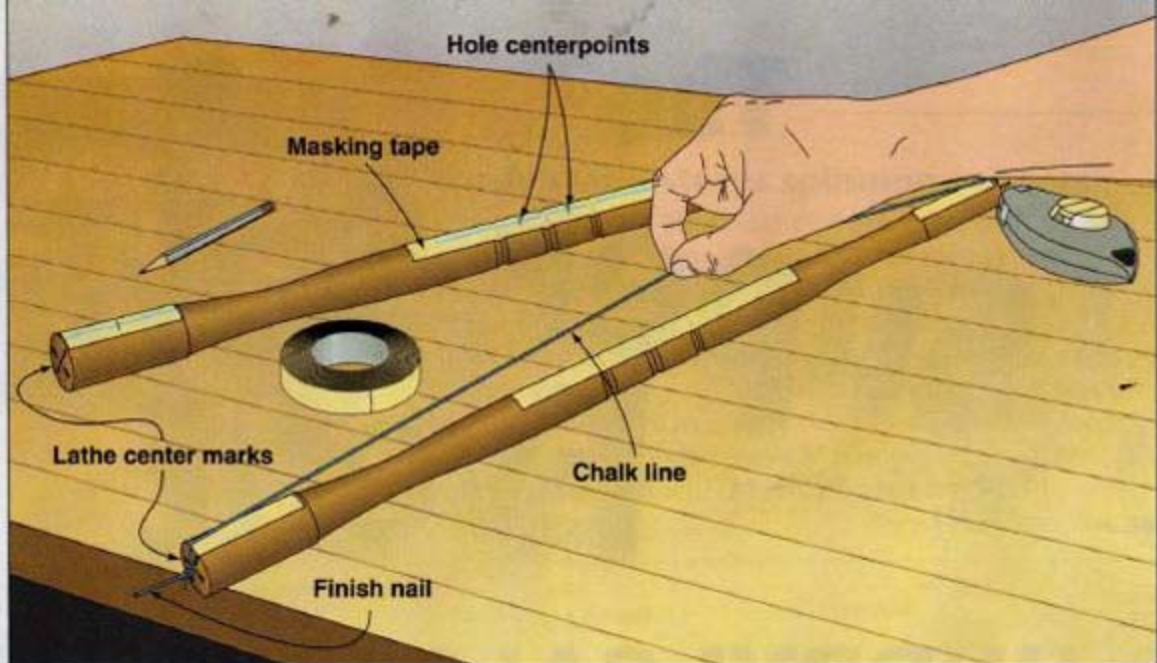

### On-the-spot solution for stubborn splinters

If you're one of those woodworkers (and I know you are) who gets hard-to-remove, little splinters, I have a nifty trick for you. Simply put a drop of wood glue onto the spot, and cover it with a bandage until the next morning. When the glue dries, it will grab the splinter and just peel it out when you remove the bandage.

—Gerald Tavernier, Niles, Mich.



## PROUD OF WHAT YOU MAKE?

### US, TOO.

Introducing



Circle #100 from the makers of Drill Doctor.

### Cutting Edge Technology for Woodworkers

Take a look at our latest project. It's the result of years of work, listening to woodworkers like you, and then building the wood tool sharpener that you wanted. Take a tour of the features and see what you think:

580 rpm wheel speed—  
Powerful 1/5 HP Motor

Sharpening Port Lapping Surface—  
"plunge-pull" sharpening technique and Sharpening Port abrasive increases burr removal and speeds sharpening

150mm Tempered Glass Grinding Wheel— provides an always flat and true, maintenance-free grinding surface on which to adhere PSA Abrasives

Sharpening Port— enables precise and repeatable angles of 20°, 25°, 30°, and 35° for chisels and plane irons up to 2" wide



Dry Cooling System— routed airflow and heat sink system keeps tools cool without the mess of a wet system



Learn more about the award-winning Work Sharp at

[www.worksharptools.com](http://www.worksharptools.com)

or call 1-800-597-6170

Ask for it at Rockler, Woodcraft, and wherever you buy your tools.



Innovative Edge-Vision™ Slotted Wheel lets you see the cutting edge as you sharpen!

## One curve you can cut on a tablesaw

How can you make a tenon on a dowel or spindle if you don't own a lathe? You can use your tablesaw, as shown in the drawing at right.

I first set up my rip fence to define the length of the tenon. Then, starting with the blade down and running, I hold the dowel into the crotch formed between the scrap board and the tablesaw top, and raise the blade slowly to create the shoulder depth of the tenon. Finally, I rotate the dowel to complete the shoulder cut and then nibble away to the end of the tenon by passing the dowel back and forth across the blade.

—Robert Shillinglaw, Ames, Iowa

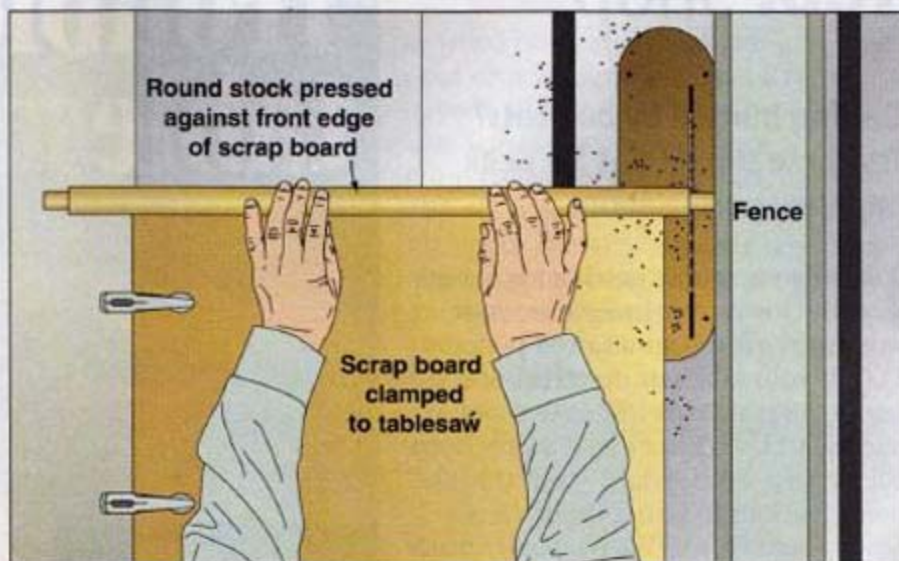

# ARE YOU READY FOR THIS?



**Drill Doctor**  
The Drill Bit Sharpener

### Check all that apply:

- I have a collection of old dull drill bits I just can't throw away.
- I'd rather spend my money on new tools than on buying more drill bits.
- I know I should sharpen my drill bits, but I don't have time to become a sharpening expert.
- I want to drill clean, precise holes every time.
- I'm tired of searching through all of my used bits trying to find one sharp enough to use.

If you checked any of these, you're ready to sharpen your drill bits with Drill Doctor, THE Drill Bit Sharpener. See it in action online at

[www.drilldoctor.com](http://www.drilldoctor.com)

1-888-MYDRILL (693-7455)

Look for the Drill Doctor at Sears, The Home Depot, Lowes, Northern Tool, and wherever you buy your tools.

## Mount doors simply with singular stile

One of my biggest hang-ups has always been the installation of cabinet doors. Keeping an awkward door aligned and in place with one hand while drilling with the other drove me half nuts.

My solution: Cut an extra stile when making the door parts. I use the extra stile to align the hinges on the cabinet frame and drill pilot holes as shown. Further, if the hinge locations are symmetrical, I can flip it around and use it for both left and right door installations.

Even overlay doors can be aligned this way before drilling because the stile can be closed against the frame for measuring. And there is usually still room to look past it and get a drill around it.

—Mike Harman, Great Mills, Md.

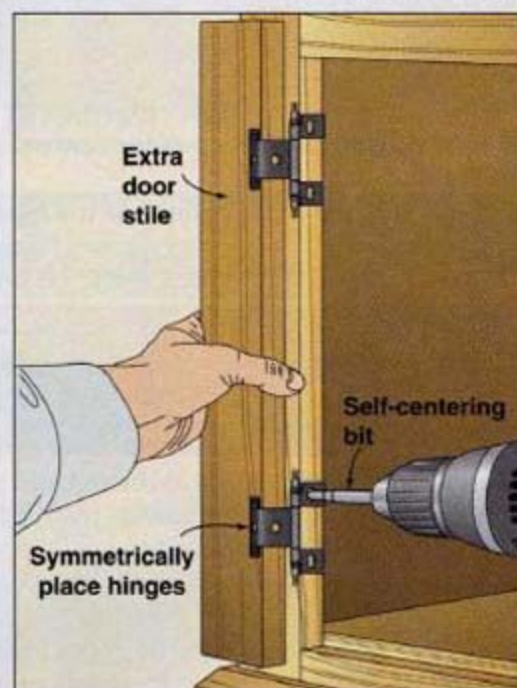

## Tool Shop

Getting burned by bad cuts? Try these simple tips for peak tablesaw performance.

Just as your spouse needs a night out on the town once in a while, your woodworking machines need periodic TLC. If your tablesaw doesn't produce smooth, square cuts free of tear-out, burn marks, and scoring, it might need adjustment. Fortunately, your bad cuts hold the clues to fixing them. Here's how to read them. (We purposely made poor-quality cuts and then rubbed a stick of blue chalk over the edges to indicate the flaws. Rip-cut samples show the effects on the "keeper" portion between the rip fence and blade. Crosscut samples are from the left side of the blade.)

# Troubleshooting tablesaw cuts

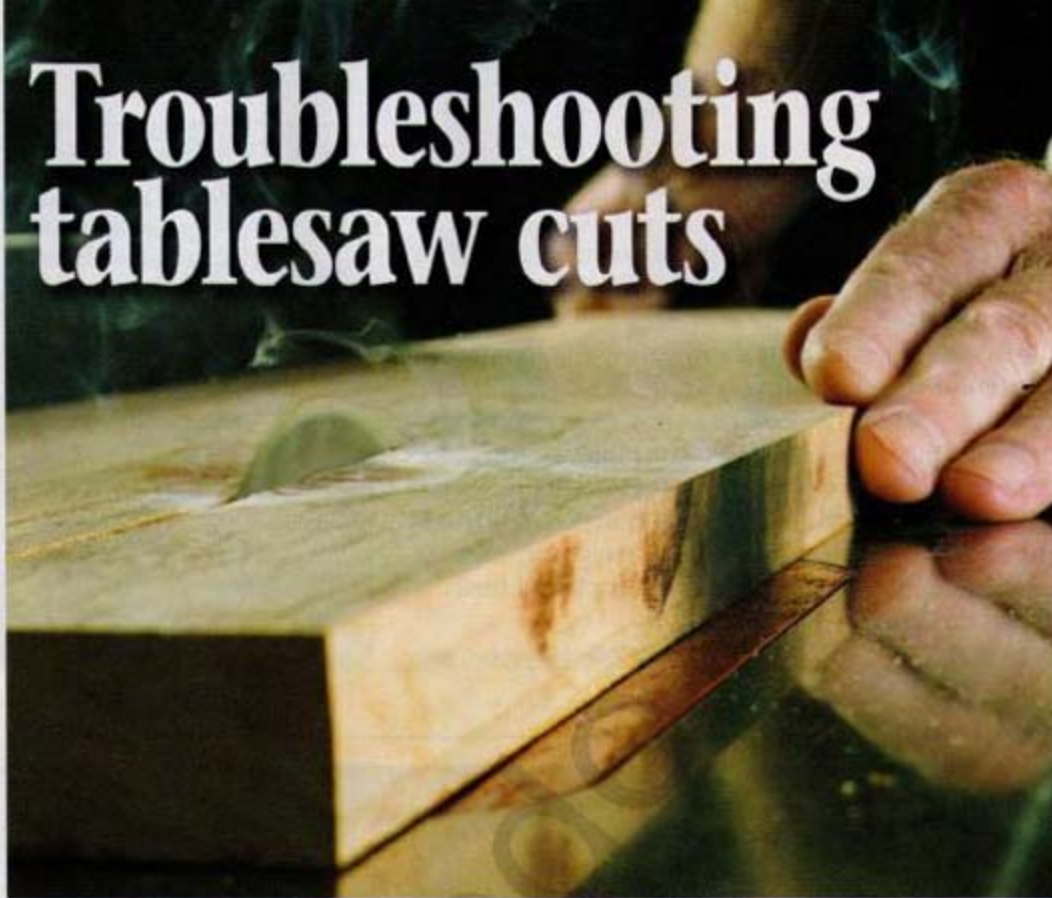

### If your rip cuts look like this...



■ The outfeed side of your blade is scoring the edge after the infeed side has already made the cut.

#### To fix it...

- Make sure the miter slot is perfectly parallel with the blade.
- Align your rip fence parallel to the miter slot.
- Use a splitter (or riving knife if your saw has one) to keep boards from encroaching on the back of the blade. (This also helps prevent kickback.)

### If your rip cuts look like this...



■ Your rip fence opens up at the outfeed side of the blade.

#### To fix it...

- Align your rip fence parallel to the blade.

### If your rip cuts look like this...



■ Your rip fence closes up at the outfeed side of the blade, pinching your workpiece against the blade. (Note the gouge at the trailing end of the board, resulting when the blade body no longer supports it and the carbide teeth take a bite.)

#### To fix it...

- Align your rip fence parallel to the blade, allowing it to toe away from the blade 0.002" to avoid potential kickback.

### If your cuts look like this...

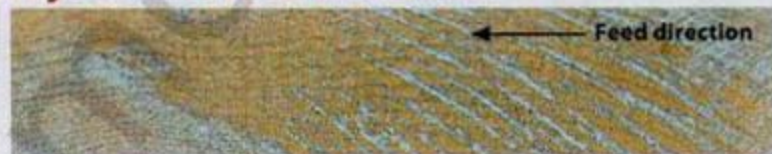

■ Your blade deflects slightly during the cut—more typical of thin-kerf blades.

#### To fix it...

- Add a stabilizer or blade stiffeners between your blade and the arbor flange/nut.
- Replace it with a new full-kerf (1/8") blade.

### If your bevel cuts look like this...



■ Your tablesaw's bevel stops are either set inaccurately or have sawdust build-up.

#### To fix it...

- Remove all caked-on dust from the stops.
- Following the directions in your tablesaw's manual, recalibrate the bevel stops using an accurate angle gauge or combination square.



### If your crosscuts look like this...

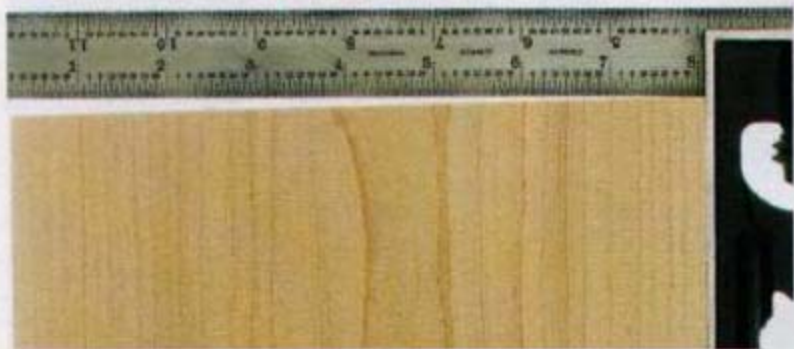

- Your miter gauge or sled is not accurately set.  
**To fix it...**
- Use a reliable square—we like Starrett combination squares—to adjust your miter gauge or sled to 90°.

### If your crosscuts look like this...

■ It's because fibers break away from the workpiece at the blade exit point.

#### To fix it...

- Attach an auxiliary fence to your miter gauge. It acts as a zero-clearance backer when the blade exits the cut at

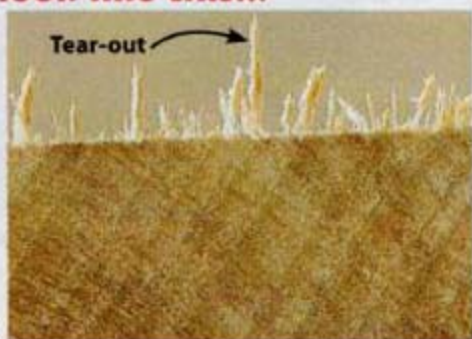

the edge, supporting the wood fibers and eliminating tear-out.

- For bottom-face tear-out on a workpiece, install a zero-clearance insert plate in your tablesaw. (To learn how to make one, go to [woodmagazine.com/zeroclearance](http://woodmagazine.com/zeroclearance).)
- For top-side chip-out (on oak-veneered plywood, for example), score the cutline first on your tablesaw with a 1/16"-deep cut on that face. Or, apply painter's masking tape over the cutline, which minimizes splintering, but won't pull fibers loose so long as you remove it gently.

### If your cuts look like this...



- Your blade is burning the wood.  
**To fix it...**
- Clean any pitch buildup—which increases friction and heat—from your blade using a cleaner, such as Empire BladeSaver. (See **Source** below.)
- Increase your feed rate. A slow feed rate can cause such species as maple and cherry to burn even when using a sharp blade.
- Replace your blade with a sharp one.

#### Source:

Blade cleaner: Empire BladeSaver, 16 oz., \$22, [amazon.com](http://amazon.com).

# Are you buying the best?

- I**NNOVATIVE  
Unique fully integrated soft grip handle
- S**UPERIOR  
40% More Clamping Force than 500QC series QUICKGRIP Bar Clamps\*
- D**EPENDABLE  
Value Priced Clamps for over 100 years

Bar/Spreader Clamp

## "Jorgensen" ISO

Adjustable Clamp Co. Chicago, IL 60622  
[www.adjustableclamp.com](http://www.adjustableclamp.com)

\* When tested using the same input force. Quick-Grip is a registered trademark of Irwin Industrial Tool Company.

# Box-slotting Bits

These tiny cutters save a ton of time when building drawers or decorative boxes.



**B**oxes are the basic building blocks of woodworking. Think about it: A drawer is merely a box with a handle; a dresser, a big box full of drawers. Sometimes, we build decorative boxes just for the sake of making boxes. One of the tricky parts about making boxes has always been how to machine the slot for the box bottom without leaving ugly gaps on the outside corners.

Here's one great solution: special box-slotting bits that rout the slot for an  $\frac{1}{8}$ "- or  $\frac{3}{16}$ "-thick box bottom without leaving

those annoying gaps. Each bit comes with two bearings that let you choose the depth of the slot, either  $\frac{1}{8}$ " or  $\frac{3}{16}$ " deep.

Because you rout the slot with the box dry-assembled, there's little chance of slotting the wrong face or edge of the workpiece. And, the bit cuts only on the inside of the box so you can put the slot exactly where you want it. Even on boxes with complex joinery—double dovetails, crescent-and-pin joints, etc.—you'll never worry about accidentally cutting through your carefully made corners.

## How to use the bit: 5 simple steps to successful slotting

### 1 INSTALL AND ADJUST THE BIT

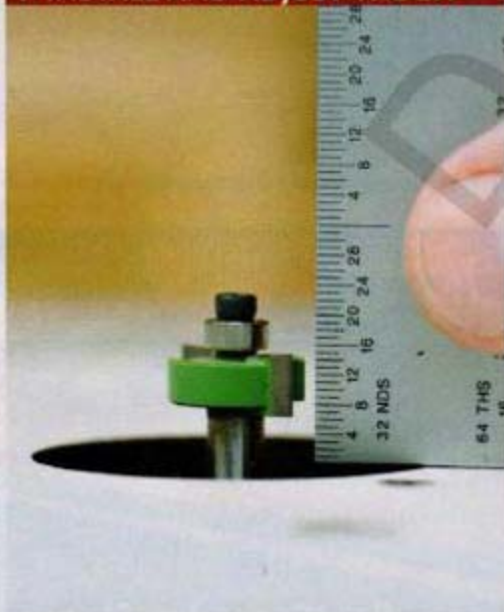

Install the bit in a table-mounted router and set the cutting height. For a  $\frac{1}{8}$ "-deep slot, use the large bearing; for a slot that's  $\frac{3}{16}$ " deep, mount the small bearing instead.

### 2 DRY-ASSEMBLE THE BOX



Without using glue, assemble the box and clamp it together. We prefer to use a band clamp, but a set of bar clamps, as shown here, also will do the trick.

### 3 ROUT THE BOTTOM SLOT



Avoiding corners as a starting point, plunge the box into the spinning bit and machine the slot around the inside of the box, completing the cut as shown above.

#### 4 CUT THE BOTTOM TO FIT



Size the box bottom to fit in the slots, cutting it about  $\frac{1}{32}$ " narrower and shorter than the actual dimensions to allow some movement. Mark a  $\frac{3}{4}$ " radius on each corner. (We used a circle template.)

#### 5 SHAPE THE CORNERS



Round the corners of the bottom using a rasp or sander. Check the fit of the bottom in the box, and if satisfied, disassemble the dry-fit box and glue it together. Glue a plywood bottom in the slot to add strength. For a solid-wood bottom, a dab of glue in the center of each end slot will keep the bottom from rattling. 🌲

#### Source

Box-slotting bits. \$26.20 each from Lee Valley Tools (800-871-8158, leevalley.com). For  $\frac{1}{8}$ "-thick box bottoms, order bit no. 16J83.02, or for  $\frac{1}{4}$ "-thick bottoms, order bit no. 16J83.04.

# OVERARM BLADE COVER SYSTEM

with dust collection capability

ITEM 50-EXBC10



# Excalibur

BY GENERAL INTERNATIONAL

For current promotions, complete product info and a list of dealers near you:

[WWW.GENERAL.CA](http://WWW.GENERAL.CA)



4" main boom with telescopic 3" inner boom.

Easy to install & simple to use - connects to standard 4" dust hose.

Maximize dust collection efficiency with any dust collector without compromising safety.

Heavy-duty see-through blade cover with spring loaded swing arm raises & lowers to suit stock thickness.

**UNIQUE DESIGN MOUNTING BRACKET:  
PIVOTS ARM AWAY OR REMOVE COMPLETELY  
IN SECONDS**

Circle No. 1552

# WOODCRAFT®

For A Free Catalog Or To Find Your Local Woodcraft Store,  
Visit [www.woodcraft.com](http://www.woodcraft.com) Or Call 800-542-9115.

**P**innacle is defined by Webster's as *the highest point of development or achievement*. The latest offering of router, drill press table systems and a variety of accessories that bear the Pinnacle® name have certainly lived up to this definition. Every detail of these Pinnacle® tools was engineered with one thing in mind: to provide woodworkers with tools that empower them. Pinnacle® tools are available exclusively at Woodcraft.



Pinnacle®  
Drill Press Table



Pinnacle®  
Mag-Jig Bracket



Pinnacle®  
Premium Coping Sled



Pinnacle®  
Router Bit Rack



Pinnacle®  
Clamp Racks



Pinnacle®  
Premium Router Table System



Dept: 08W107R

**QUALITY WOODWORKING TOOLS SUPPLIES • ADVICE®**

Circle No. 700

# Great Ideas for Your Shop

Up-against-the-wall

## Shorts & Sheet Goods Rack

Stacking and sorting sheet goods and short stock just got a whole lot easier with this simple-to-build organizer. This angled rack features: wall-hugging space efficiency; angled uprights for easily sorting through numerous sheets with minimal worry of having the outside sheet fall over as you view pieces behind it; and areas between the uprights for storing short and narrow sheet goods or boards.

You can build the rack as dimensioned at *right*, or shorten or lengthen it to fit your storage space. We used plywood for the uprights, pine boards for the rest. Predrilling the shank and pilot holes keeps the wood from splitting when assembling with screws. For best organization, keep the larger sheet goods next to the uprights and the smallest pieces to the front.

Project design: **Chuck Hedlund, Kevin Boyle**

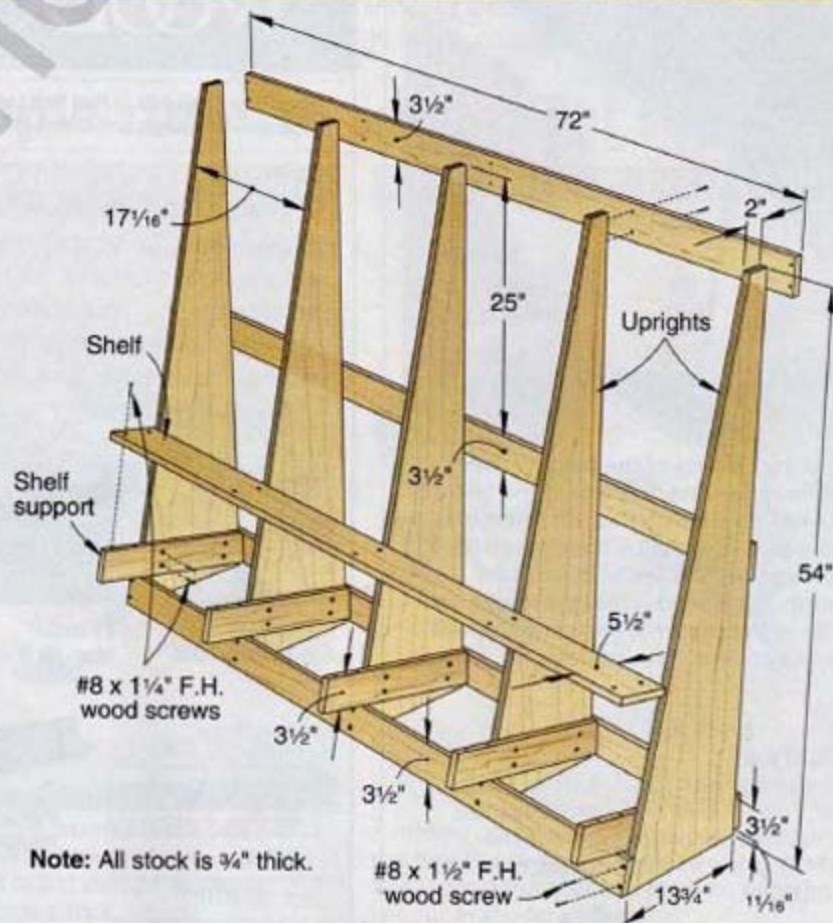

### SHELF SUPPORT

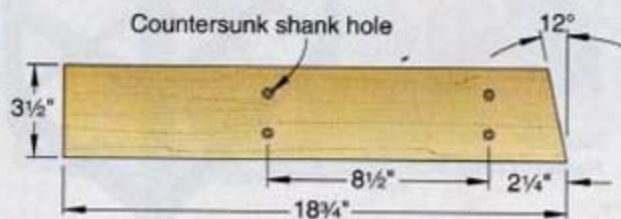

Find more shop-organizer plans at:  
[woodmagazine.com/freeplans](http://woodmagazine.com/freeplans)



Note: All stock is 3/4" thick.



"PERFORMANCE"

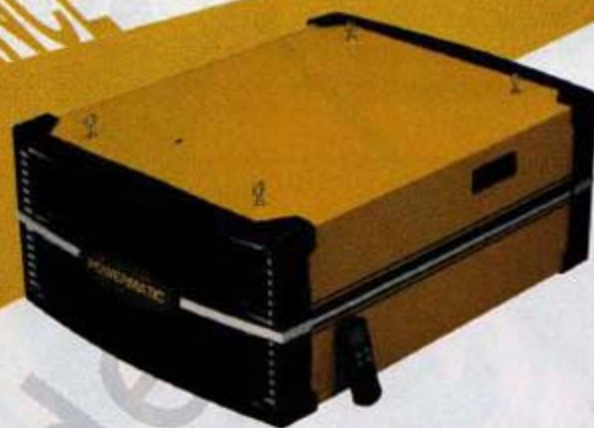

## Filtration At Its Finest

Your shop may look clean, but how clean is the air? Take no chances when it comes to your health. The all-new Powermatic PM1200 Air Filtration System traps up to 99% of all 5-micron and 1-micron particles known to cause health risks. Clean air is so important, and Powermatic has made it easier than ever to attain with an Instant Filter Access Assembly, Radio Frequency (RF) Remote and Programmable Shut Off option. Trust the finest in filtration and trust in the woodworking industry's Gold Standard since 1921...Powermatic.



RF REMOTE CONTROL WITH LCD



GUARD SLIDES OFF WITHOUT TOOLS, FOR INSTANT FILTER ACCESS

FOR MORE INFORMATION  
PLEASE VISIT  
**Powermatic.com/wood**

©2004 BAKER TOOL COMPANY, INC. The color GOLD is a registered trademark of Baker Tool Company, Inc.

# Avoiding Workshop Goofs

## Dangerous Curves Ahead!



How to rout rounded workpieces without troublesome tear-out

**F**ew things frustrate a woodworker like painstakingly shaping a curvy workpiece, only to have a router bit tear out the grain during final machining. Tear-out occurs when the spinning bit encounters grain that isn't strongly supported by its own structure. It often happens in the transition area from end grain to edge grain, where the wood gives way along the grain, as shown *above*, rather than accepting the shape of the bit. Although tear-out can occur during any routing operation, curved pieces are particularly prone.

Here are some general rules to help reduce the chances for tear-out:

- **Use a sharp bit.** Dull bits chop at the wood rather than slice it cleanly.
- **Rout in  $\frac{1}{8}$ "-deep increments** to limit the amount of material being removed at one time.
- **Maintain a wide stance** (feet at least shoulder-width apart) to avoid being caught off-balance.

### Divide and conquer

Before putting the router to the wood, identify the tear-out-prone "danger

zones" on your workpiece, as marked with chalk in **Photo A**. Routing these zones in a normal left-to-right (counterclockwise) direction increases your chances for tear-out. Instead, climb-cut the danger zones: right to left (clockwise) on outside edges, and left to right (counterclockwise) on interior edges.

Begin by routing the edges not prone to tear-out as usual [**Photo B**]. Next, climb-cut the tear-out-susceptible areas [**Photo C**]. Repeat these steps until you achieve the finished depth of cut. Finally, rout the entire profile in

### SNEAK UP ON TEAR-OUT-PRONE AREAS WITH SHALLOW CLIMB CUTS



**A** Danger zones feature grain that parallels the edge and is prone to tear-out.



**B** Rout the areas unlikely to tear out before moving on to the danger zones.



**C** Climb-cut the danger zones, holding the router firmly to guard against jerking.

the usual direction to remove any bumps or ridges caused by the jumpy climb cut.

### More helpful tips

■ **When possible, climb-cut using a handheld router** with your workpiece clamped securely to the bench, rather than attempting it on a router table. Why? Because climb cutting—routing in the same direction

as the rotation of the bit—on a router table can pull the workpiece from your grip, throwing it off the table. It also exposes your hands to the spinning bit.

■ No matter whether a workpiece edge curves outward (as with the tabletop shown *opposite*) or inward (as on the shelf brackets [Photo D]), climb-cut troublesome areas to prevent tear-out.

■ Workpieces that narrow near the end [Photos D and E] might tear out no

matter which direction you rout. To avoid this, cut the piece oversize, rout the curved edge, and then rout the piece to final size [Photo F].

■ When using a template to create a workpiece, cut away the waste material as close to the cutline as possible. Then, when you rout with a flush-trim or pattern bit, you can run the router in either direction with little chance of tear-out. 🌲

#### SAVE TAPERED POINTS FROM BREAKAWAY



**D** The unsupported tip of this shelf bracket broke away as the router made a simple round-over beaded profile.

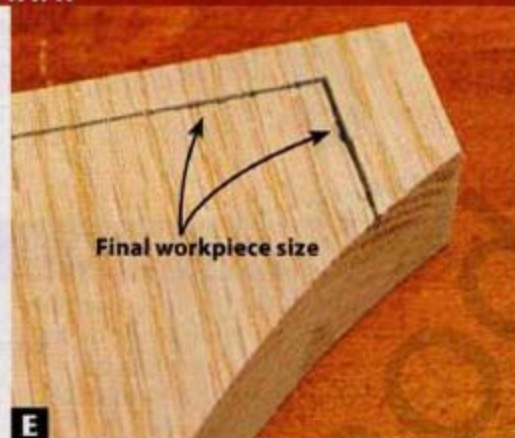

**E** By leaving extra material to back up the bracket point, any tear-out will happen on the waste side of the line.

#### A CLOSE SHAVE WORKS BEST



**F** Leave about 1/16" of waste material so the router needs only to shear off fine shavings rather than large chips that cause tear-out.

woodmagazine.com

29

## Create a Beautiful Pen in Minutes

If you're looking for an easy, relaxing and rewarding woodworking hobby that won't break the bank — then pen making is for you.

Impress your friends and family with the gift of a beautiful hand turned pen. The perfect hobby for quick and attractive projects. Make a pen with Penn State Industries' 5-step/15 minute process.

**Get started now with our all-inclusive, Super Pen Making Starter Set.**



The result . . .  
an elegant "Slimline" pen.

**SAVE \$120**

on our Super Pen Making Starter Set

Regularly \$595 **NOW \$475**

with FREE Shipping

Order item #PK073PWB

#### Starter Set includes:



Turncrafter Pro Midi Lathe



40 Slimline Kits HSS Chisel Set



Sandpaper Set Insert & Trimmer



Mandrel Set 40 Wood Blanks



Finishing Wax Glue



Instructional DVD Pen Press

Code WM08

Circle No. 2151





**Penn State Industries**

1-800-377-7297 • www.pennstateind.com/getstarted

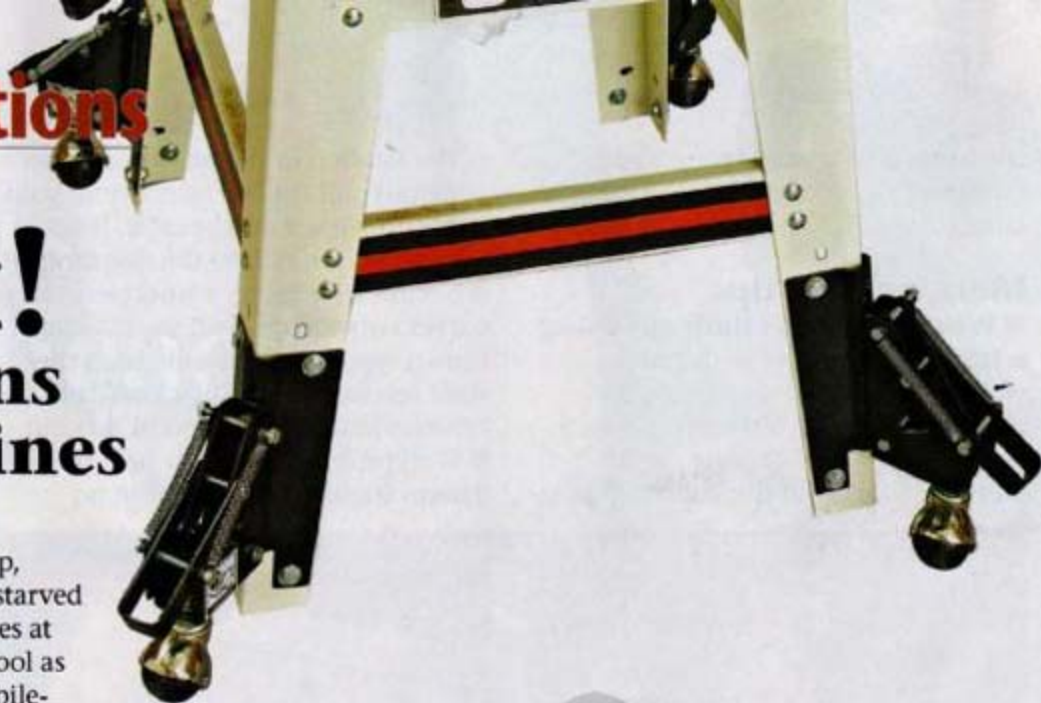
## Move it! Mobility options for shop machines

**N**o matter how large or small your shop, mobile bases make sense. In a space-starved shop, you can have a fleet of machines at the ready along one wall and roll out each tool as you need it. Here are five of our favorite mobile-base options.



Mobile Base	▲ Pros/Cons ▼	Buy this if...	Capacities
<b>Delta Mobile Machinery Base</b> no. 50-941, \$70  <p>800-223-7278 deltaportercable.com</p>	<ul style="list-style-type: none"> <li>Requires only minor assembly.</li> <li>One-step locking/unlocking.</li> <li>The leveling pads can be adjusted separately to stabilize the base.</li> <li>Bases can't be resized.</li> <li>The center-mounted wheel can allow tools to tip slightly while they're being moved.</li> </ul>	<p>...your tool footprint fits one of the bases. Install this and other bases with the two fixed casters mounted perpendicular to a table saw's fence to reduce accidental movement.</p>	<p>19½×22" (Bases come in 28 sizes from 13½×18½" to 26¼×28½") Each holds 20 percent more than the weight of its tool. Bases raise tools ⅞".</p>
<b>HTC3000 Universal Mobile Base, \$100</b>  <p>800-624-2027 htcproductsinc.com</p>	<ul style="list-style-type: none"> <li>Optional 18" rails available.</li> <li>No bending. Foot-pedal locks keep the fixed casters from turning to reduce accidental rolling; two other foot pedals raise and lower the rotating casters.</li> </ul>	<p>...you need to fit a variety of moderately heavy tools. For lighter tools, the HTC 2000 (\$48) adjusts from 12×12" to 36×36" or 20×52" and holds up to 500 lbs.</p>	<p>From 14×14" to 22×54". 700-lb maximum machine weight. Base adds ¼" to the tool height.</p>
<b>Shop Fox Super-Heavy Duty Mobile Base</b> no. D2058, \$90  <p>800-840-8420 shopfox.biz</p>	<ul style="list-style-type: none"> <li>Lots of weight capacity.</li> <li>Optional extension rails (no. D2246) increase the length to 45¼" to support table saw extensions.</li> <li>The heaviest of the bases shown here at 61 lbs.</li> <li>Pad screws must be turned by hand to raise the tool.</li> </ul>	<p>...you need the ability to move extremely heavy tools such as cabinet saws and 8" jointers. The hand-turned pad screws make this a better choice for tools you move infrequently.</p>	<p>From 18×24½" to 28½×33½". 1,300-lb maximum machine weight. Base adds 1" to the tool height.</p>
<b>Woodcraft Universal Mobile Base</b> hardware no. 145488, \$60  <p>800-225-1153 woodcraft.com</p>	<ul style="list-style-type: none"> <li>Low cost.</li> <li>You can easily resize the base by cutting a new ¾" plywood panel.</li> <li>Leveling pads adjust separately to compensate for uneven surfaces.</li> </ul>	<p>...you want maximum flexibility in tailoring the base to your tool. Because you can make the base wider than the tool base, it's also a good choice for adding stability to the tool.</p>	<p>From 12×12" to 37×37". 600-lb maximum machine weight. Base adds 2" to the tool height.</p>
<b>Woodcraft Retracting Casters</b> no. 141550, \$40 (Installed casters shown at top.)  <p>800-225-1153 woodcraft.com</p>	<ul style="list-style-type: none"> <li>All four casters rotate, easing storage in tight spaces.</li> <li>Tools rest on their own pads with no added height.</li> <li>You'll likely need to drill four 1½" holes in each leg to bolt casters at the right height.</li> <li>Each caster must be raised and lowered separately.</li> </ul>	<p>...you're just moving a contractor-style saw over fairly smooth surfaces. The ball caster's narrow, curved bearing surface can catch on cracks.</p>	<p>Castors add no height to the saw when retracted. Four casters can carry a 600-lb machine. 🌱</p>





# Grizzly Industrial

IWFA VISIT US AT  
2008 BOOTH  
AUG. 20TH THROUGH  
AUG. 23RD #5435

PURVEYORS OF FINE MACHINERY®, SINCE 1983!

## 10" WET GRINDER KIT - 90 RPM

Made in Germany, this 90 RPM Wet Grinder with leather stropping wheel will sharpen just about any cutting tool to a razor sharp edge in no time at all. It is so versatile and simple to use, you'll wonder why you ever put up with dull edges before. Add the optional accessories for even greater sharpening convenience.



### SPECIFICATIONS:

- 220 grit grinding wheel is specially made for wet grinding
- 90 RPM wheel speed
- Grinding wheel size: 10" dia. x 2" wide
- Water bath keeps tools cool while sharpening
- Leather stropping wheel size: 8" dia. x 1 1/4" wide

Standard equipment includes a universal jig, angle guide and polishing/honing paste.



New!

**T10010**  
10" WET GRINDER KIT  
AMAZING INTRODUCTORY PRICE  
MADE IN GERMANY  
**\$169<sup>95</sup>**

### OPTIONAL ACCESSORIES

#### T10023 Accessory Kit #1

Includes fixtures for sharpening small knives, large knives, scissors and axes. *Made in Asia.*



#### T10024 Accessory Kit #2

Includes a stone dresser and fixtures for sharpening scrapers, screwdrivers and hollow chisels. *Made in Asia.*



#### T10025 Jig for Sharpening 16" Planer Blades

Sharpens planer and jointer blades up to 16" long. *Made in Germany.*



Ideal for  
wood turners,  
wood workers &  
knife makers!



- MODEL T10023** Accessory Kit #1 for T10010 Grinder **ONLY \$59<sup>95</sup>**  
**MODEL T10024** Accessory Kit #2 for T10010 Grinder **ONLY \$44<sup>95</sup>**  
**MODEL T10025** Jig for Sharpening 16" Planer Blades **ONLY \$139<sup>95</sup>**



T10023 Scissors Sharpening



T10024 Chisel Sharpening

3 GREAT SHOWROOMS!  
BELLINGHAM, WA • MUNCY, PA • SPRINGFIELD, MO



**1-800-523-4777**

TECHNICAL SERVICE: 570-546-9663 • FAX: 800-438-5901

**grizzly.com**



OVER 12,000  
PRODUCTS  
ONLINE!

MEDIA CODE WOODM0806B

10481

# The perfect host Outdoor Server



See a Slide Show of this project coming together at [woodmagazine.com/slides](http://woodmagazine.com/slides)

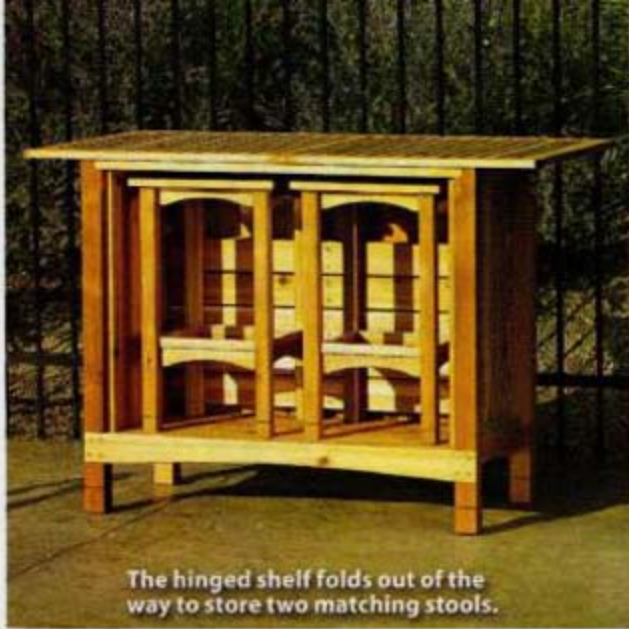

The hinged shelf folds out of the way to store two matching stools.

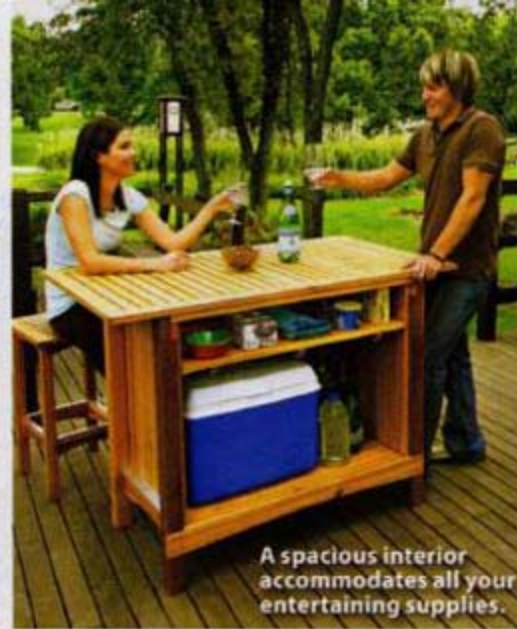

A spacious interior accommodates all your entertaining supplies.

## PROJECT HIGHLIGHTS

- Overall dimensions: 53¼" wide x 30" deep x 36" high.
- Readily available project materials give you the convenience of one-stop shopping at your local home center.
- Simple joinery means you can pick up your materials on Saturday morning and be ready to apply the finish by Sunday afternoon.
- For the lumber and other items needed to build this project, see page 38.

## Skill Builder

- Learn an easy way to form a row of closely spaced mortises, without chopping them individually, by cutting a groove and gluing in filler blocks.

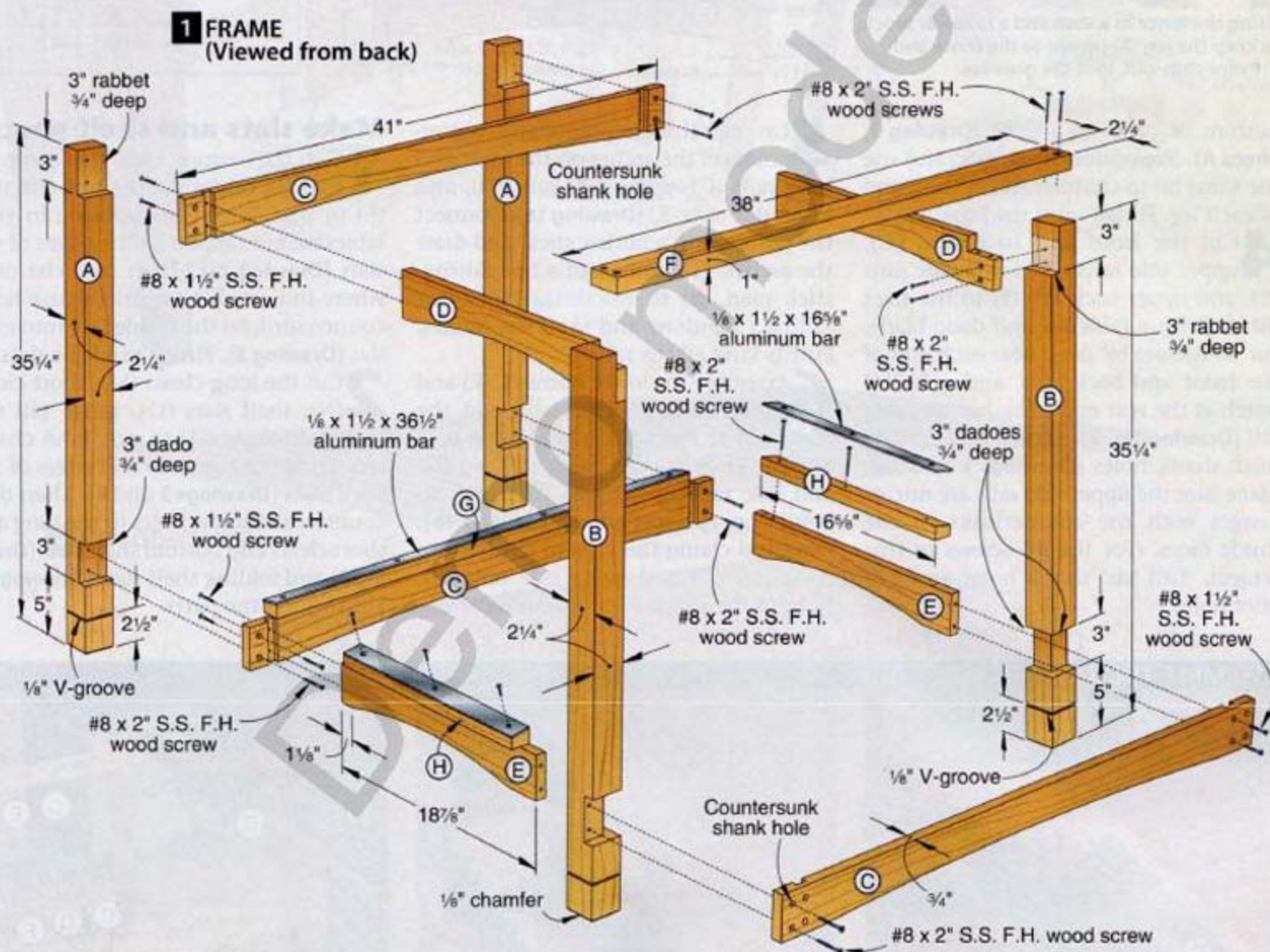

This project completes the patio suite that started with the outdoor Bistro Table in issue 177 (July 2007) and continued with the Bistro Stool left in issue 178 (September 2007). You'll find that it employs the same simple and sturdy construction, making it a perfect weekend endeavor.

## Build the base

**1** For the front legs (A) and back legs (B), cut four 36"-long pieces of 4x4. (We used cedar. You can laminate thinner stock using polyurethane or Titebond III glue.) Then joint, resaw, and plane them to 2¼x2¼, and cut them to finished length [Materials List, page 38].

**2** Install a dado blade in your table saw, and cut a 3" dado and 3" rabbet in each front leg (A). Then cut two 3" dadoes and a 3" rabbet in each of the back legs (B) [Drawing 1].

**3** Chuck a V-groove bit into your table-mounted router, and rout the decorative 1/8"-deep grooves near the

## ROUT THE LEG V-GROOVES

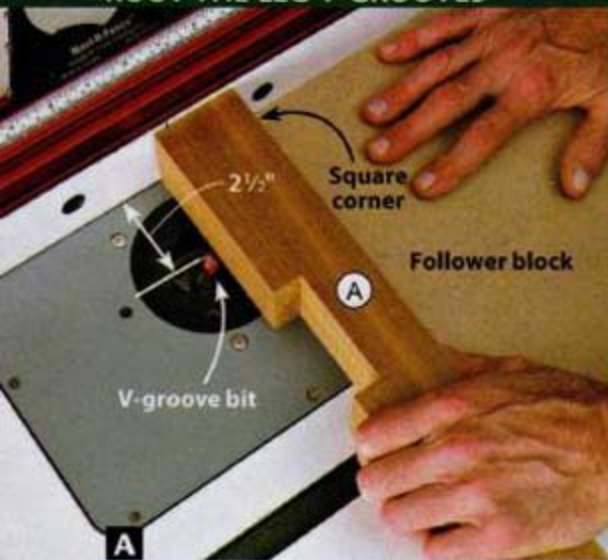

Using the fence as a stop and a follower block to keep the leg (A) square to the fence and prevent chip-out, rout the grooves.

bottom of each leg (A, B) [Drawing 1, Photo A]. Reposition the fence, and use the same bit to chamfer the bottom end of each leg. Finish-sand the legs.

**4** Cut the front and back rails (C), upper side rails (D), lower side rails (E), and upper back rail (F) to the sizes listed. With a tablesaw and dado blade, cut  $\frac{3}{4}$ " dados  $\frac{3}{8}$ " deep near each end of the front and back rails, and a  $1 \times 2\frac{1}{4}$ " notch at the rear end of each upper side rail [Drawing 1a]. Then drill the countersunk shank holes [Drawings 1 and 1a]. Make sure the upper side rails are mirror images with the countersinks in the inside faces. (For the #8 screws in this project, drill  $\frac{5}{32}$ " shank holes and  $\frac{3}{32}$ " pilot holes.)

## 1a RAILS

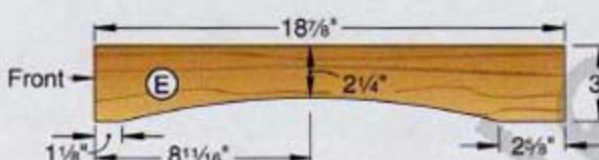
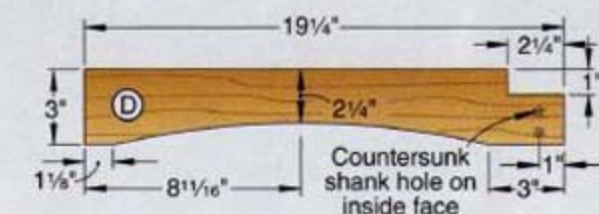
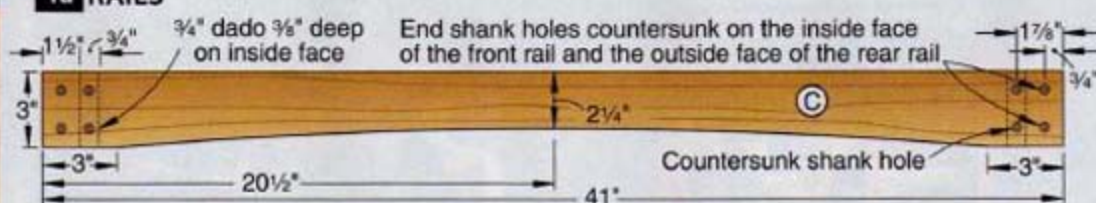

## 1b RAIL CAP END VIEW



**5** Lay out the endpoints and center-points of the arches on the front and back rails (C), upper side rails (D), and lower side rails (E) [Drawing 1a]. Connect the points with a fairing stick, and draw the arches. (To download a free fairing-stick plan, go to [woodmagazine.com/fairing](http://woodmagazine.com/fairing).) Bandsaw and sand the arches. Finish-sand all the rails.

**6** Assemble the lower frame (C/E) and upper frame (C/D/F) and add the legs (A, B) to form the base [Photos B, C, and D]. Then cut the front rail cap (G) and side rail caps (H) to size, and rip bevels on the top edges [Drawing 1b]. Glue and clamp the caps to the bottom front rail (C) and lower side rails (E), flush at the inside edges [Drawing 1].

## Make slats and shelf parts

**1** Cut the corner slats (I), common slats (J), center slat (K), and end slats (L) to size. With a dado blade in your tablesaw, cut rabbets in the edges of the slats [Drawing 2a]. Then rout chamfers where indicated. Now drill shank holes countersunk on the inside face into each slat [Drawing 2]. Finish-sand the slats.

**2** Cut the long cleats (M), short cleats (N), shelf slats (O), hinge rail (P), and shelf cleats (Q) to size. Rout chamfers along the top ends and edges of the shelf slats [Drawings 3 and 4]. Then drill countersunk screw holes in the long and short cleats and bottom shelf slats [Drawing 3] and folding shelf slats [Drawing 4]. Finish-sand the parts.

## ASSEMBLE THE BASE

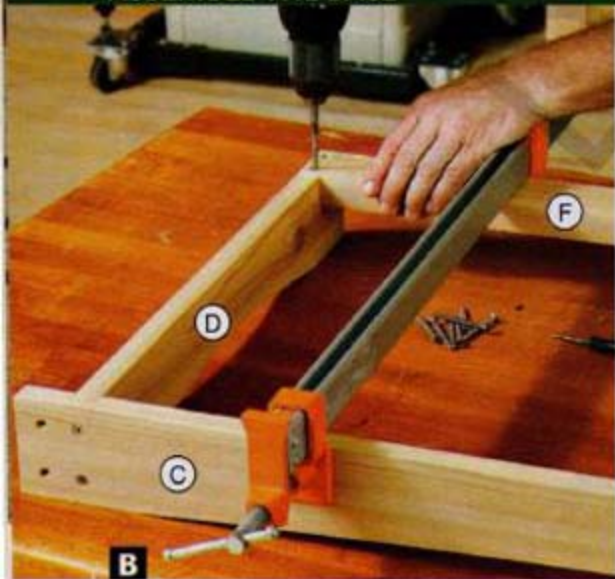

Glue and clamp the upper side rails (D) into the front rail (C) dados and the upper back rail (F) into the side rail notches. Drill pilot holes, and drive the screws.



Glue and clamp the lower side rails (E) into the front and back rail (C) dados. Using the shank holes in the front and back rails as guides, drill pilot holes, and drive the screws.

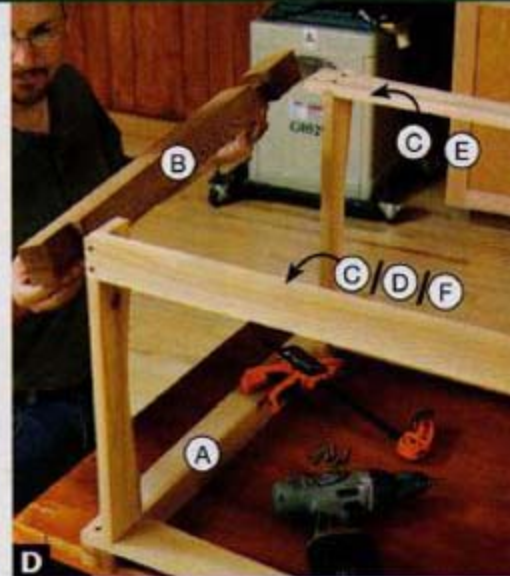

Join the frames (C/D/F, C/E) by gluing and screwing the front and back rails (C) and the upper side rails (D) into the dados and rabbets in the front legs (A) and back legs (B).

## 2 SLAT ASSEMBLY

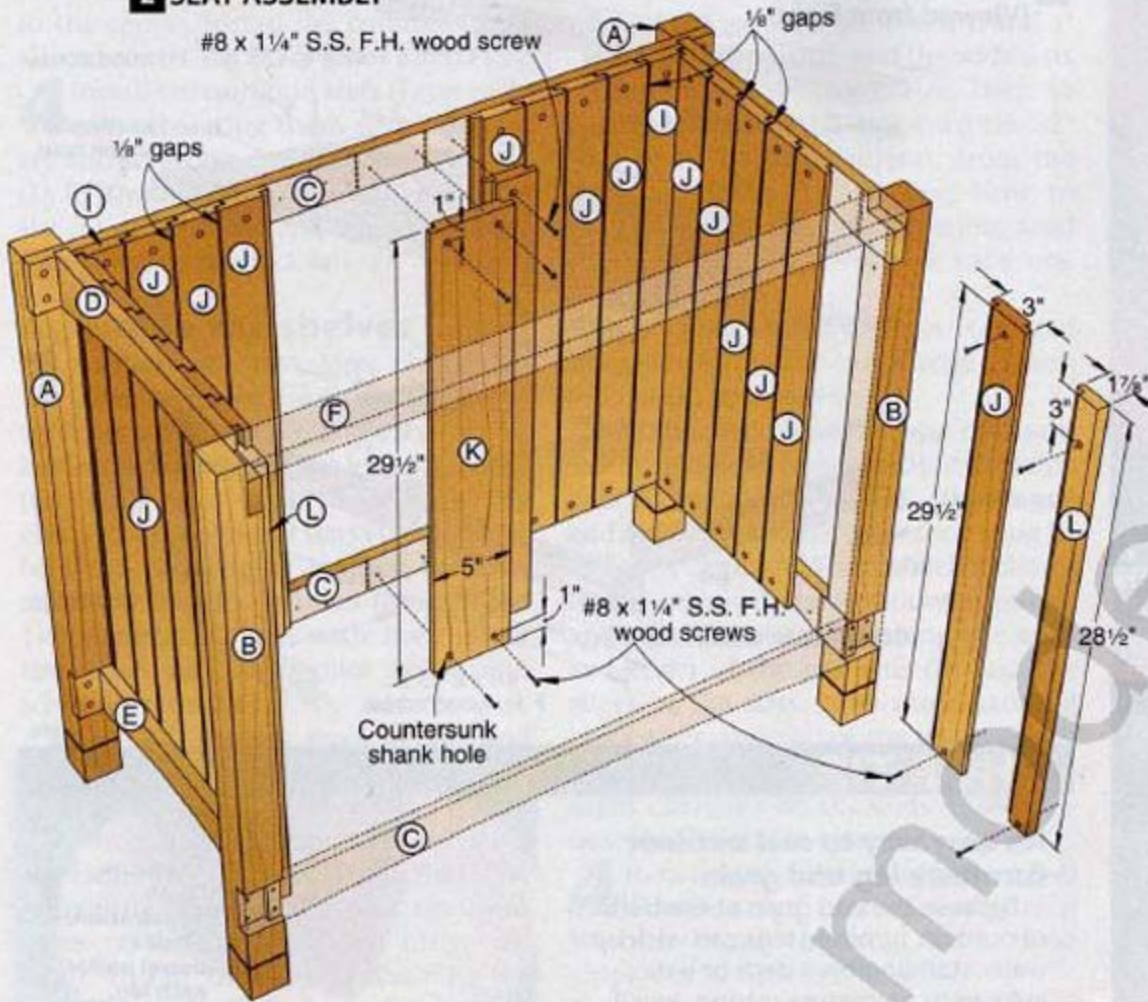

## 2a SLAT END VIEWS

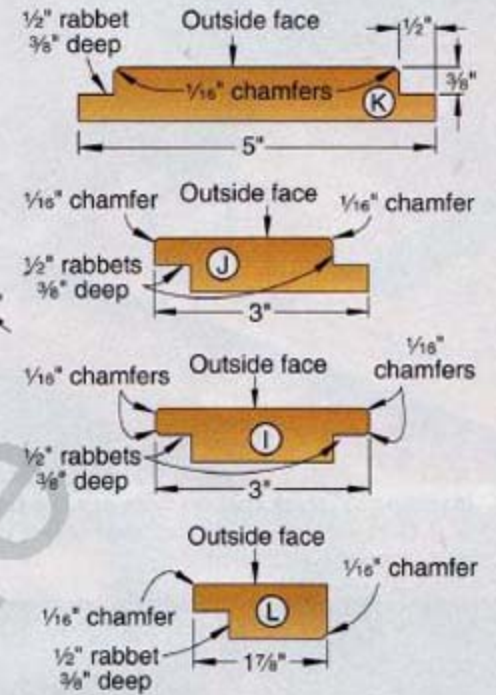

## 3 EXPLODED VIEW

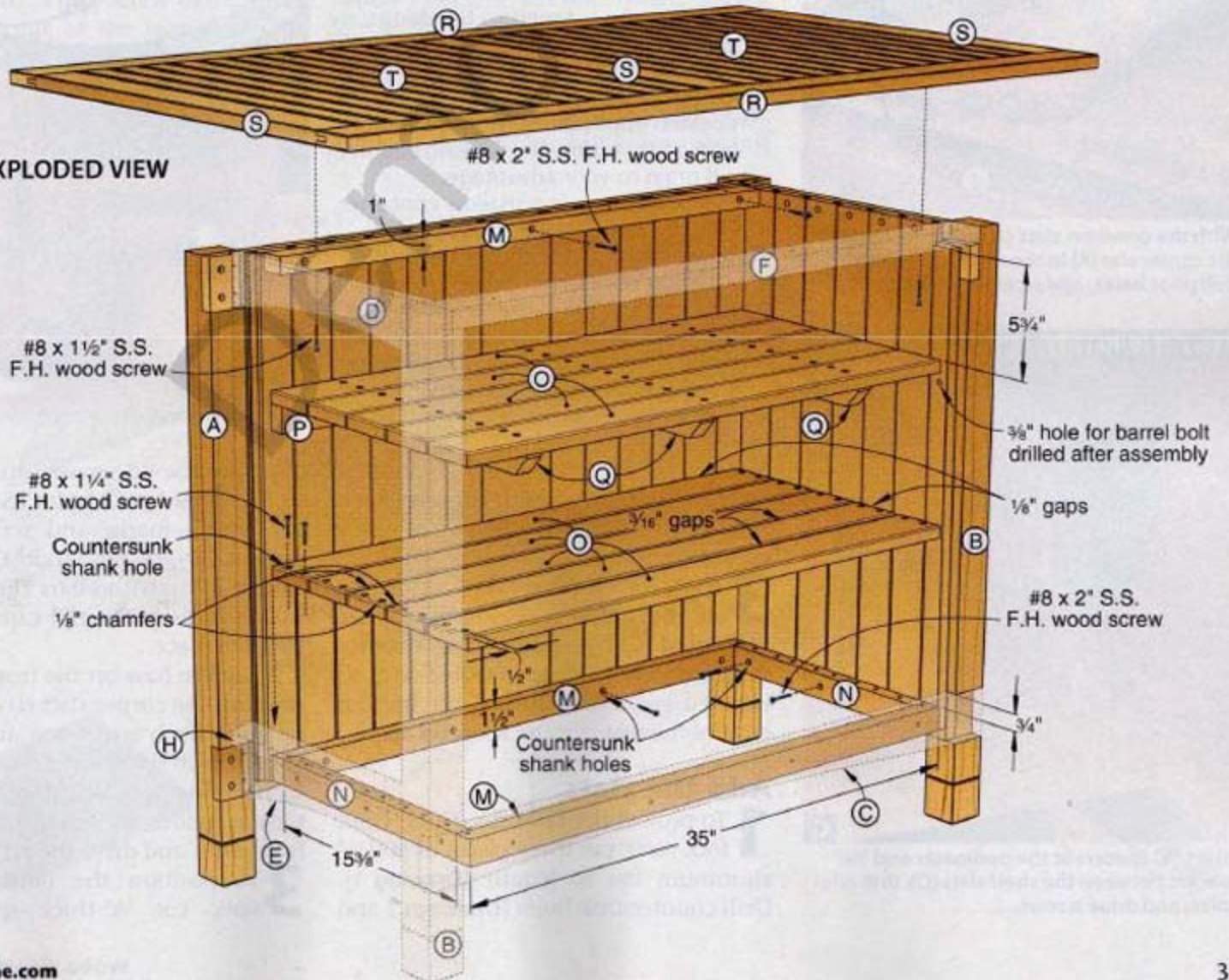

## INSTALL THE FRONT SLATS



Inserting  $\frac{1}{8}$ "-thick spacers between the slats (I, J), drill pilot holes into the front rails (C), and screw the slats in place.



With the common slats (J) fastened, center the center slat (K) in the remaining space, drill pilot holes, and screw it in place.

## ADD THE BOTTOM SHELF SLATS

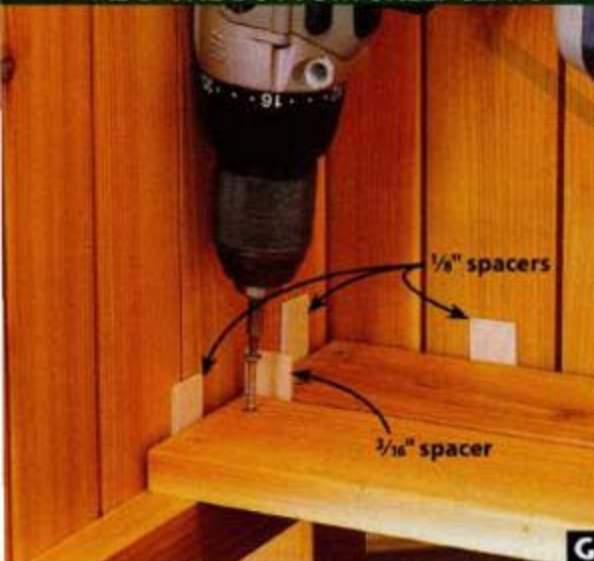

Insert  $\frac{1}{8}$ " spacers at the perimeter and  $\frac{3}{16}$ " spacers between the shelf slats (O), drill pilot holes, and drive screws.

## 4 FOLDING SHELF (Viewed from front)

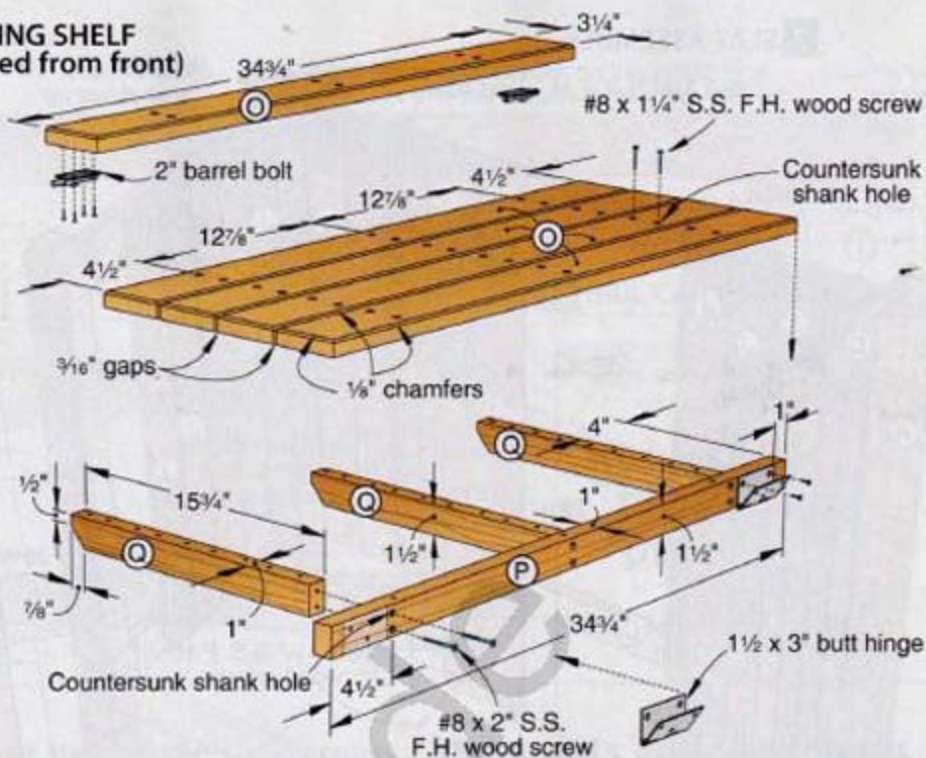

## SHOP TIP

### An easy way to seal outdoor furniture leg end grain

Because the end grain at the bottom of outdoor furniture legs can wick up water standing on a deck or patio, leading to premature rotting, you'll have to make extra effort to adequately seal them. Of course, end grain absorbs finish almost as well as water, so brushing on the finish will require repeated applications. Here's a simple solution that turns the wicking action of end grain to your advantage.

Place each leg in a shallow container, and pour finish in the containers, as shown at right. The photos show the matching stools from issue 178 (September 2007). After a few hours, the grain will be saturated. Then turn the furniture upside down, wipe away any excess finish, and let it dry.



To ensure finish penetration, place a dowel under each leg.

**Note:** Drill the countersunk screw holes through the 1" thickness of the two lower long cleats (M) and the 1 1/2" width of the upper long cleat.

**3** Apply two coats of exterior finish to all the parts, including the base. (We used Cabot translucent exterior stain no. 3002 Cedar.) Double-coat all exposed end grain. To seal the bottom ends of the legs, see the **Shop Tip** above.

### Add the slats

**1** To protect the rail caps (G, H) from foot wear, cut three pieces of  $\frac{1}{8}$  x  $1\frac{1}{2}$ " aluminum bar to length [Drawing 1]. Drill countersunk holes [Drawings 1 and

1b]. (For the #6 screws, drill  $\frac{3}{4}$ " shank holes and  $\frac{5}{8}$ " pilot holes.) Sand the bars to remove marks and scratches. (We used a 320-grit 3M Sandblaster sanding sponge.) Align the bars flush with the inside edges of the rail caps, and screw them in place.

**2** Lay the base on the front, and position the corner slats (I) on the front rails (C) flush at the top and with one edge of each slat against the side rails (D, E) [Drawing 2]. Using the holes in the slats as guides, drill pilot holes into the front rails, and drive the screws.

**3** To position the remaining front slats, cut  $\frac{1}{8}$ "-thick spacers from

scrap. Then, working from the corners to the center, install the common slats (J) and center slat (K) [Photos E and F].

**4** Install six common slats (J) on each end, separating them with  $\frac{1}{8}$ " spacers and screwing them to the side rails (D, E) [Drawing 2]. Then install each end slat (L) with the top end against the bottom of the upper back rail (F).

### Assemble the shelves

**1** Position the two long cleats (M) with the screw holes through the 1" thickness and the short cleats (N)  $\frac{3}{4}$ " below the top edge of the lower back rail (C). Drill pilot holes, and screw the cleats to the common slats (J) and lower back rail [Drawing 3]. Position the long cleat with the screw holes through the 1 $\frac{1}{2}$ " dimension flush with the tops of the front slats, drill pilot holes, and screw it to the slats (J, K).

**2** Cut  $\frac{3}{16}$ " spacers from scrap, and screw five shelf slats (O) to the cleats (M, N) [Drawing 3 and Photo G].

**3** Assemble the hinge rail (P) and shelf cleats (Q) [Drawing 4]. Add the remaining five slats (O) with the front edges of the front slat and hinge rail flush. Install the folding shelf in the base [Photo H]. Then screw barrel bolts to the underside of the rear shelf slat, flush with each slat end, and with the center of the bolt 1" from the rear edge. Mark a bolt hole location in each end slat (L) [Photo I], and drill  $\frac{3}{8}$ " holes.

### Make the top

**1** Cut the top rails (R) to width and 1" longer than listed, and the wide slats (S) and narrow slats (T) to size. Then, to position the fillers (U) later, cut a 1 $\frac{1}{2}$ "x32" strip of  $\frac{1}{4}$ " hardboard. Next, from the strip, cut 12 spacers 2 $\frac{1}{2}$ " long. Now, to indicate proper spacer orientation, sand chamfers on two corners of each one [Drawing 5a].

**2** On your tablesaw, cut centered grooves into the inside edge of each top rail (R) [Drawing 5].

**3** With a dado blade in your tablesaw, form tenons on the ends of the wide slats (S) and narrow slats (T) [Drawings 5 and 5b]. Check the tenons for a snug fit in the  $\frac{1}{4}$ " grooves. Then chuck a chamfer bit into your table-mounted router, and rout  $\frac{1}{16}$ " chamfers along the ends and edges of the top rails (R) and the edges of the slats. Now use a sanding block to chamfer all of the tenon shoulder edges. To ease assembly later, sand slight chamfers on the ends of the tenons. Finish-sand the slats.

**4** To make the fillers (U), first rip two  $\frac{1}{4}$ "-wide strips from the edge of a  $\frac{3}{4}$ "-thick board 18" long. From these strips, cut 52 fillers  $\frac{3}{8}$ " long.

**Note:** The grain runs across the  $\frac{3}{8}$ " dimension of the fillers.

**5** Dry-fit a wide slat (S) tenon into one top rail (R) groove with the edge of the slat and the end of the rail flush. Glue a filler into the rail groove against

### INSTALL THE FOLDING SHELF

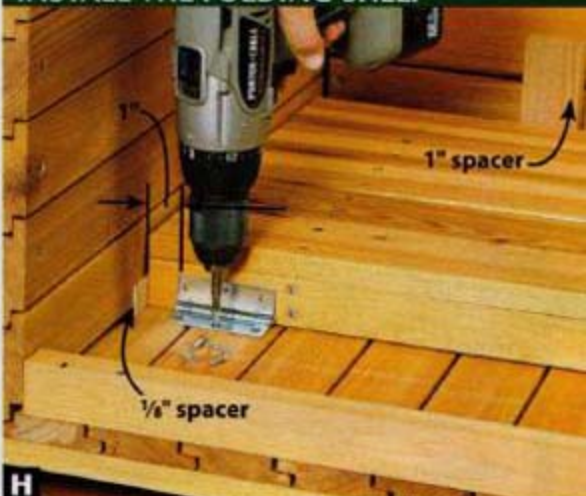

**H** Position the folding shelf in the base with  $\frac{1}{8}$ " spacers at the sides and 1" spacers at the bottom. Screw the hinges in place.

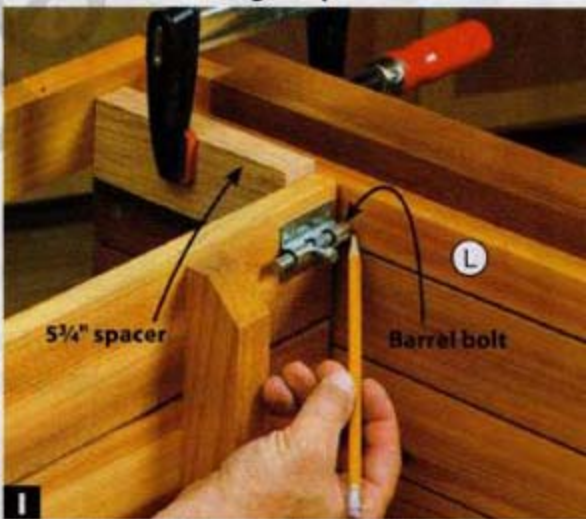

**I** Pivot the shelf into the upright position against a 5 $\frac{3}{4}$ "-long spacer. Mark the location for the barrel bolt hole on the end slat (L).

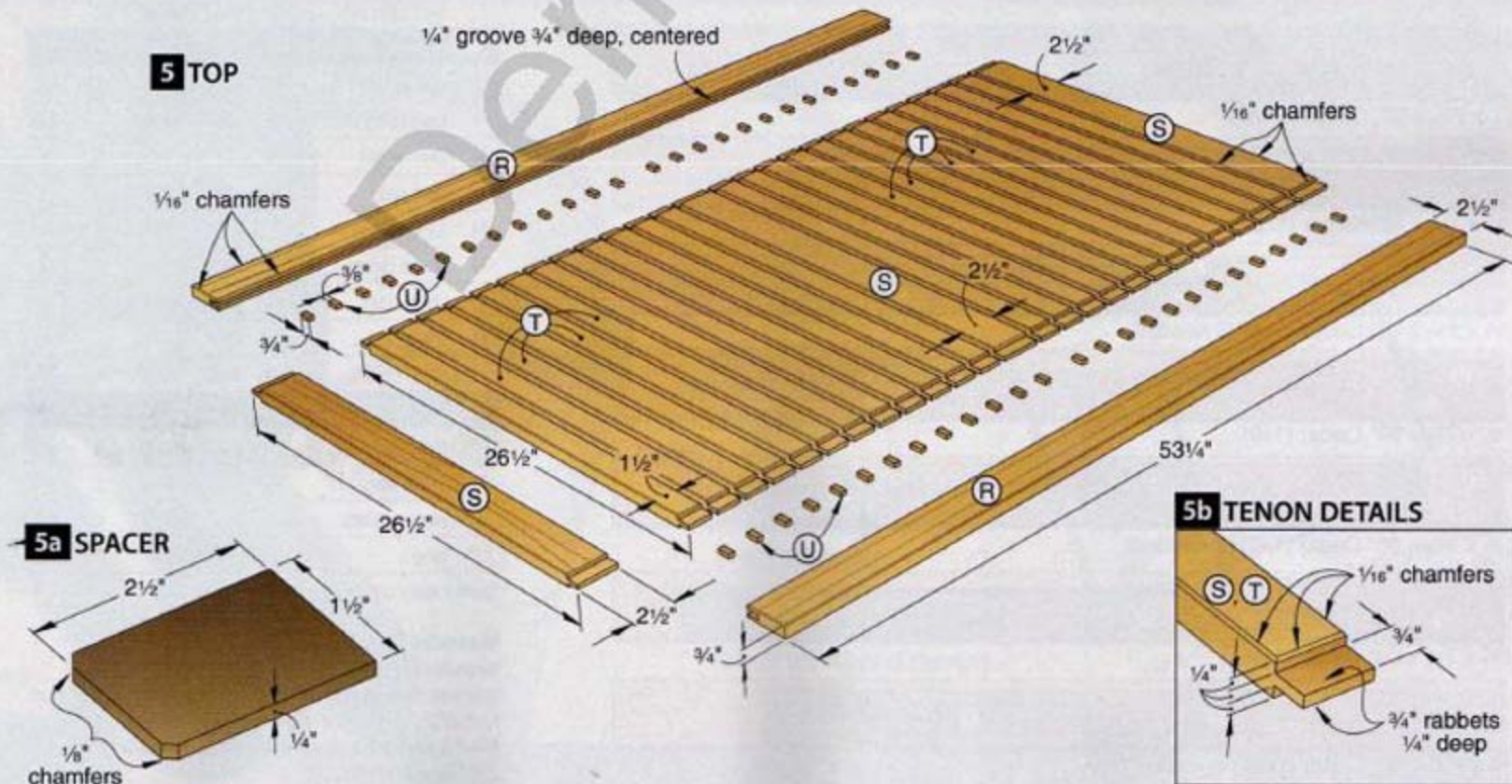

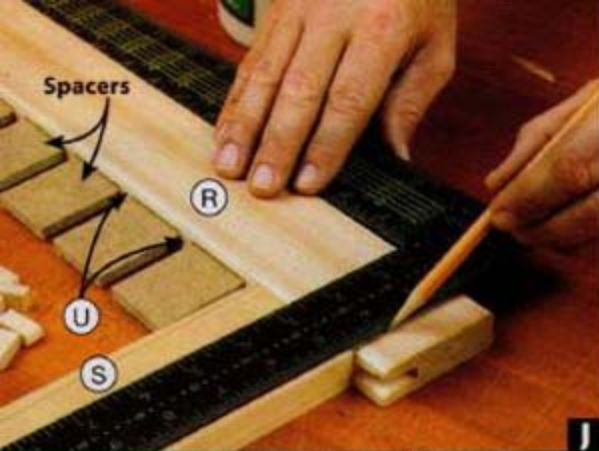

### MARK THE TOP RAIL LENGTH

With the three wide slat (S) tenons inserted into the rail (R) groove, and all the fillers (U) glued in place, mark the rail length.

the slat. Then insert a spacer and glue in another filler. Repeat until you've used the twelve spacers and positioned 13 fillers. Insert the center wide slat (S). Now carefully remove the 12 spacers and use them to repeat the filler-gluing process on the other half of the rail, using all the spacers again and positioning 13 additional fillers. Insert the tenon of the last wide slat into the rail groove, and mark the finished length of the rail [Photo J]. Remove the slats and spacers, and trim the rail to length. Repeat with the second rail. Finish-sand the rails.



### ASSEMBLE THE TOP

Holding one rail (R) in the bench vise, brush glue into the rail mortises, and insert the wide slat (S) and narrow slat (T) tenons.

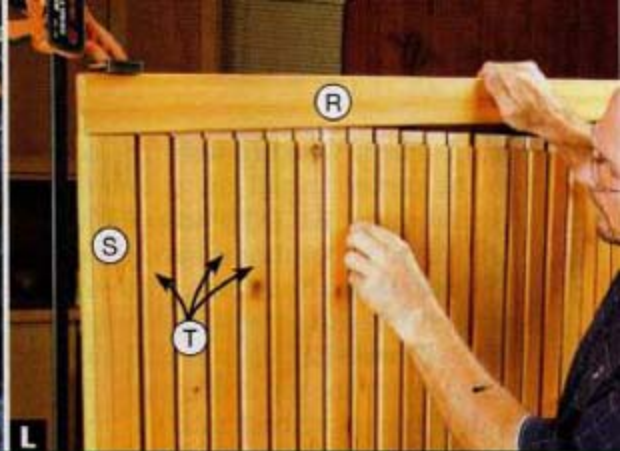

Brush glue into the second rail (R) mortises and lower it onto the slat (S, T) tenons, applying light clamp pressure at one end.

**6** Apply two coats of exterior finish, double-coating the rail (R) end grain. Avoid getting finish on the slat (S, T) tenons and into the rail mortises formed by the groove and fillers (U).

**7** Remove excess glue from the rail (R) mortises with a chisel. Dry-fit the slat (S, T) tenons into the mortises. Then assemble the top [Photos K and L]. With all the slats in place, apply clamps, and check the top for square.

**8** Carry the base and top onto the deck or patio. Center the top on the width of the base with a 1/4" overhang at

the back. Drill countersunk screw holes through the upper back rail (F) and upper long cleat (M), and into the narrow slats (T) and rear top rail (R). Drive the screws [Drawing 3]. Now stock the server with snacks and cold drinks, and pull up one of the stools you made from issue 178 (September 2007). 🌱

Written by **Jan Svec**

Project design: **Jeff Mertz**

Illustrations: **Roxanne LeMoine; Lorna Johnson**

## Cutting Diagram



3 1/2 x 3 1/2 x 96" Cedar (4x4) (2 needed)

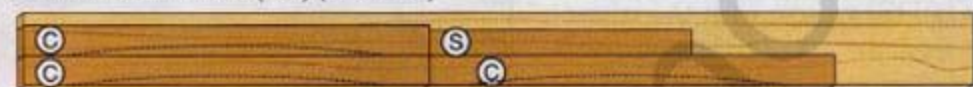

3/4 x 7 1/4 x 96" Cedar (1x8)



1 x 7 1/4 x 96" Cedar (5/4x8)

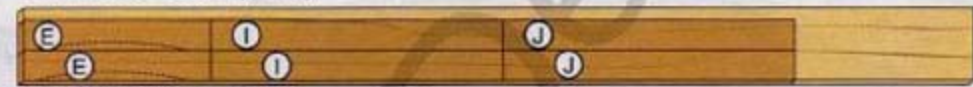

3/4 x 7 1/4 x 96" Cedar (1x8)



3/4 x 7 1/4 x 96" Cedar (1x8) (3 needed)



3/4 x 7 1/4 x 96" Cedar (1x8)



3/4 x 7 1/4 x 96" Cedar (1x8) (2 needed)

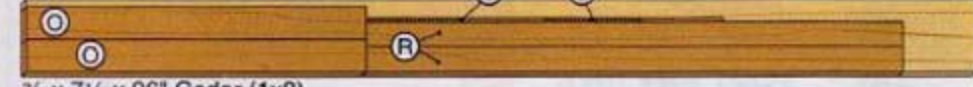

3/4 x 7 1/4 x 96" Cedar (1x8)



3/4 x 7 1/4 x 96" Cedar (1x8) (2 needed)

## Materials List

Base	FINISHED SIZE			Matl.	Qty.
	T	W	L		
A* front legs	2 1/4"	2 1/4"	35 1/4"	C	2
B* back legs	2 1/4"	2 1/4"	35 1/4"	C	2
C front and back rails	3/4"	3"	41"	C	3
D upper side rails	3/4"	3"	19 1/4"	C	2
E lower side rails	3/4"	3"	18 5/8"	C	2
F upper back rail	1"	2 1/4"	38"	C	1
G front rail cap	1"	1 1/4"	36 1/2"	C	1
H side rail caps	1"	1 1/4"	16 5/8"	C	2
<b>Slats and shelves</b>					
I corner slats	3/4"	3"	29 1/2"	C	2
J common slats	3/4"	3"	29 1/2"	C	22
K center slat	3/4"	5"	29 1/2"	C	1
L end slats	3/4"	1 7/8"	28 1/2"	C	2
M long cleats	1"	1 1/2"	35"	C	3
N short cleats	1"	1 1/2"	15 3/8"	C	2
O shelf slats	3/4"	3 3/4"	34 3/4"	C	10
P hinge rail	1"	1 1/2"	34 3/4"	C	1
Q shelf cleats	1"	1 1/2"	15 3/4"	C	3
<b>Top</b>					
R* rails	3/4"	2 1/2"	53 1/4"	C	2
S wide slats	3/4"	2 1/2"	26 1/2"	C	3
T narrow slats	3/4"	1 1/2"	26 1/2"	C	24
U* fillers	1/4"	3/4"	3/8"	C	52

\*Parts initially cut oversize. See the instructions.

**Material key:** C—cedar.

**Supplies:** #6x1/2", #8x1/4", #8x1 1/2", #8x2" flathead stainless steel wood screws, 2" barrel bolts (2), 1 1/2x3" butt hinges (2), 1/4x1 1/2x72" aluminum bar.

**Blade and bits:** Stack dado set, V-groove and 45° chamfer router bits.



## An Entirely New **ROUT.**

Unlike conventional router tables, our all new **Precision Router Table** utilizes a self-squaring tablesaw inspired fence to dramatically improve the way you work. Because the fence always moves parallel to the miter slot, even the most minor adjustment made on the fence's scale translates perfectly to the bit. It's the kind of innovation you've come to expect from Kreg, and we're confident it will make all the difference in your shop.

➔ Visit us online to watch a video of this product in action.



Self-Squaring Fence



Steel Reinforced MDF Top



Built-In Vertical Jointer

Optional Micro-Adjuster

www.kregtool.com | 800.447.8638

Circle No. 802

## One Stop Dust Collection Solution

With 20 years experience and a superior product line, the experts at Penn State Industries will provide you effective solutions for a cleaner shop.

### TEMPEST™ Cyclones

- ▲ 2.5HP - 1450CFM - \$875
- ▲ 3.5HP - 1700CFM - \$995
- ▲ 5.0HP - 1800CFM - \$1295

### Commercial Systems

- ▲ Ideal for CNC machines, production shops & more
- ▲ 2000 CFM to 3700 CFM from \$495 to \$1220

### Premium Ductwork

- ▲ Pipe for maximum airflow
- ▲ Fittings and hoods for any application

### Ductwork Planning Service

- ▲ An accurate layout of your shop to save you hours of planning



Call Bill at 1-800-377-7297 x16 to help you plan the best solution for your shop & info on how to get a FREE ductwork plan & a FREE catalog.

**BEST in class Cyclone Filtration**  
452-700 sq. ft.  
at 1/2-micron capturing  
99.9% of particles.

Code WM09

**Penn State Industries**  
1-800-377-7297 • www.pennstateind.com/nodust1

Circle No. 2045

# All About Oak

From mighty trees to mighty nice lumber, this all-American wood will serve you better when you know it like an old friend.

**P**rized as the favorite woodworking wood among *WOOD*® magazine readers, oak (*Quercus* genus) ranks as the dominant hardwood tree in deciduous forests that span from the Midwest to the East Coast of the United States and also from southern to eastern Canada. In fact, 50 percent of many of these forests are oak. And while more than 40 species of oak make up this population, you can fit each into one of two groups: *red* or *white*.

Once cut into lumber, oak boards can look so much alike that it becomes nearly impossible to separate into its distinct species. Yet, the division into red or white proves easy and useful, particularly with the choice of projects you build, and how you finish them.

For on-the-spot identification at your local hardwoods supplier, note that one key difference between red and white oaks lies not so much in the color. (Many red oaks—but not all—have more red color than white.) Look instead at the length of the ray cells, as shown *below*. When spotting oak in the forest, let the tree's leaves provide the clues. (See *right*.)

Another characteristic of most white oak: its cells are plugged (or "occluded") with chemicals so that the wood remains impervious to liquids. That's why you'll find white and not red oak used in making wine barrels—they will not leak. These chemicals, which deter insects and rot, are why you can feel confident in building outdoor furniture with white oak.



Red Oak



White Oak

Red oak trees have points at the ends of their leaves and bitter acorns; white oaks have rounded ends and sweet acorns. In fact, white oak acorns can be dried, ground into flour, and used to bake bread.



Ray cells are fine, dark lines running lengthwise in oak. In red oak, these cell lines seldom measure more than  $\frac{3}{4}$ " in length; in white oak, they run longer, often more than  $1\frac{1}{2}$ " long.

## Geographic differences also count

Where an oak tree grows, regardless of whether it's red or white, can impact a board's stability, appearance, and price. If the tree takes root in a warm, moist climate, it grows at a faster rate resulting in growth-ring spacing of more than  $\frac{1}{4}$ ". This labels it as *Southern* or *lowland* oak (fast-grown), while oak featuring rings of narrower spacing is referred to as *Northern* or *Appalachian* oak (slow-grown). As shown *below*, board faces and end grain create a contrasting picture. This growth-ring difference also affects processing, wood color, and weight. Northern oak weighs more and dries more slowly. That said, such a geographic division may not make a difference in some oak boards. But when it does—manifested as broader face and edge grain patterns—avoid using Southern oak alongside tighter-ringed Northern oak in the same project. The contrast could draw attention.

Also note that soil minerals—not just climate—influence appearance as well. Pinker or redder red oaks often tend to hail from Northern regions; Northern white oak may exhibit a dirtier color and contain black streaks.

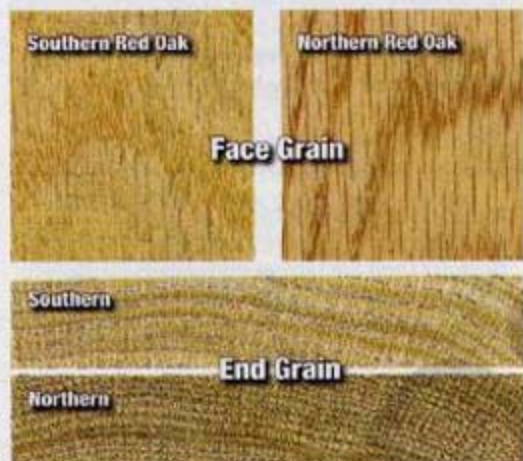

Faster-growing Southern oak tends to have wider rings than its denser, slower-growing Northern neighbor, as shown in the end grain. Being more porous, it typically weighs less. Board faces may also exhibit a deeper, wider, more exaggerated grain pattern (*above*).

## Managing machine and assembly encounters

The density, inherent strength, and brittle nature of oak can cause machining concerns. Oak tends to tear out when cross-cutting, dadoing, rabbeting, or routing. For clean machining, follow these tips:

- Acclimate lumber for the environment where it will end up. For indoor furniture, use oak with a moisture content of 6–8 percent; outdoors, 12 percent will do.

## Oak's unforgettable grain

Oak is a coarse-grained wood. That's because it has large-vessel cells that develop early in each growing season (earlywood) in each growth ring; the remainder of this yearly ring features finer wood grain (latewood). The large vessels in both red and white oak provide its signature deep, open-grained appearance. Cross-grain ray cells also add to oak's rich look. The ways in which mills slice oak logs into boards or veneer reveal these vessels and rays in varying ways that aid in selecting stock for projects.

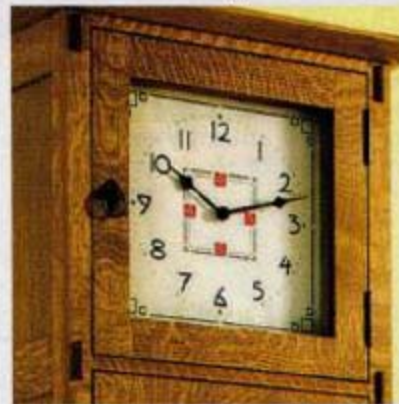

This oak Arts and Crafts clock features eye-catching ray flecks.

*Flatsawn* (known also as *plainsawn*) oak, results from cutting a log more or less parallel to the annual growth rings. This approach creates face grain containing a series of Vs, sometimes referred to as *cathedral grain*. By contrast, *quartersawing* an oak log, and then slicing off wood at 75° to 90° to the rings yields *quartersawn* oak. Here, the face grain appears as straight lines. Where the rings run perpendicular to the board face, ray cells add striking figure on the surface in the form of ray flecks. Arts and Crafts furniture makers have long appreciated this look. (See the clock, *above*.) The related term "*riftsawn*" refers to a type of quartersawn lumber that has end ring angles of 45 to 75°. Buyer beware: It's worth noting that some retailers will sell oak as quartersawn when it includes a significant amount of riftsawn wood as well.

## Putting oak to work

Because of its wide availability, looks, strength, and other characteristics, oak finds its way into many uses: furniture, cabinets, flooring, pallets, and wine barrels, to name a few. White oak's natural resistance to decay and insects makes it

- Always machine oak with razor-sharp bits and blades. You'll avoid burn marks and get crisp, clean cuts.
- When crosscutting, routing end grain, or drilling through-holes, back workpieces with scrap to prevent tear-out.
- When jointing or planing, never remove more than  $\frac{1}{8}$ " at a time. And let the grain lines be your guide; jointing and planing "with the grain" prevents deep gouging.

a good choice for outdoor applications ranging from railroad ties and landscape timbers to outdoor signs and furniture. In the "days of yore," white oak was the preferred species for building massive wooden sailing ships. (See "Oak Afloat" on page 43.)

- Joint or plane oak to thickness prior to edge-joining. Glue-join within 30 minutes of the stock's preparation.
- Use stainless-steel fasteners in outdoor projects to avoid iron staining caused by the tannic acid in oak.
- Drill pilot holes for fasteners (up to 90 percent of the screw diameter) to prevent splitting.
- For even staining, sand face grain through 220 grit, end grain through 320.

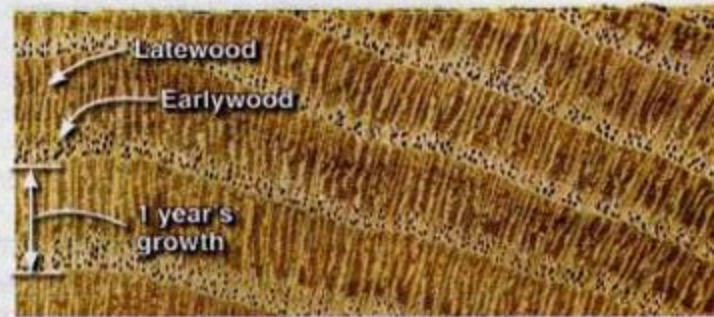
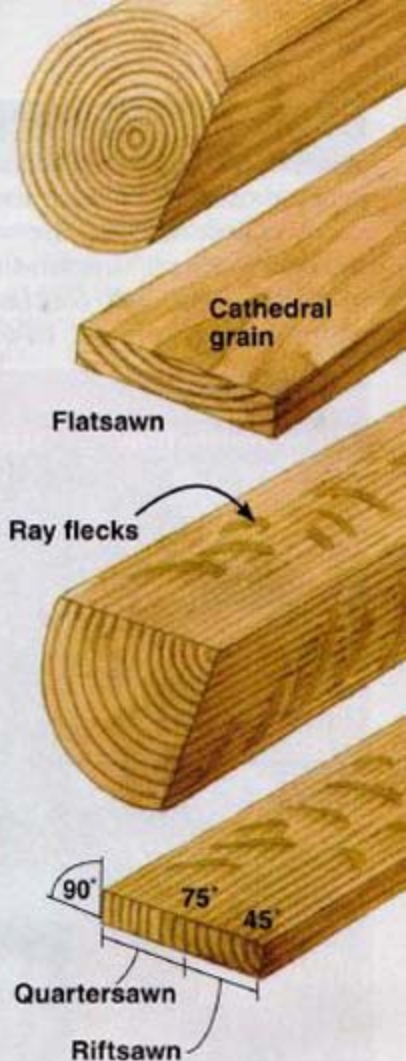

Fast-growing earlywood appears as porous lines (with tiny holes) at the end of a board; the slower growing latewood lines look more condensed. Together they equal one year's growth.

## Finishing oak with finesse

The chart below shows the look of red oak with various finishes. Because of oak's cellular structure, the pigments in oil-based stains collect more in the wood's open grain areas, while the smoother, denser, surrounding areas retain less. This can result in strong light/dark contrasts. A 180-grit final sanding may neutralize this contrast. In addition, you may find that oak has

small regions of fibers with a lot of cellulose (technically called tension wood) that absorb stain better than the other areas. Though subtle compared with pine, this uneven absorption can give oak a blotchy appearance. If it occurs on a stained and finished test piece, try sealing the next test piece prior to staining, using a conditioner, sanding sealer, or wash coat. You also can add stain pigments to the clear finish to reduce blotching.

OAK FINISH SELECTOR			
Clear Finish Type	Stain + Clear Finish	Finish Pros	Finish Cons
Oil/varnish Blend (Clear Danish Oil)	Dark Walnut Stain/ Danish Oil	<ul style="list-style-type: none"> <li>Very easy to apply</li> <li>Good moisture resistance</li> <li>Easy to maintain, just apply another coat</li> <li>Natural appearance</li> </ul>	<ul style="list-style-type: none"> <li>Slow drying time, and finish can "bleed" back out of pores for several hours</li> <li>Little or no surface protection</li> <li>Dull and lifeless appearance</li> <li>Mechanical bond only</li> </ul>
*Gloss Water-based Polyurethane	Dark Walnut Stain/ *Gloss Water-based Polyurethane	<ul style="list-style-type: none"> <li>Good clarity, no yellowing of wood</li> <li>Easy to apply</li> <li>Good moisture resistance</li> <li>Good durability</li> <li>Good for the environment</li> <li>Water cleanup</li> <li>Fast-drying; projects can be fully finished in one day</li> </ul>	<ul style="list-style-type: none"> <li>Hard to repair</li> <li>Difficult to polish</li> <li>Mechanical bond only</li> <li>Gives oak a "cold" appearance</li> </ul>
*Gloss Oil-based Polyurethane (with filled grain)	Dark Walnut Stain/ *Gloss Oil-based Polyurethane (with filled grain)	<ul style="list-style-type: none"> <li>Very durable, some tinting possible</li> <li>Great moisture resistance</li> <li>Good scratch resistance</li> <li>Good clarity</li> </ul>	<ul style="list-style-type: none"> <li>Slow-drying</li> <li>Prone to collect dust during application</li> <li>Difficult to repair and touch up</li> <li>Lifting or wrinkling may occur after second coat; avoid this by adhering to the re-coat time frame per manufacturer's directions</li> <li>Mechanical bond only</li> </ul>
*Shellac	*Dark Walnut/Shellac	<ul style="list-style-type: none"> <li>Great clarity, gives wood "depth"; orange shellac gives wood an amber hue</li> <li>Fast-drying; projects can be fully finished in one day</li> <li>Each new layer "burns" into the previous forming a chemical bond</li> <li>Easy to tint with alcohol dyes</li> <li>Easy to repair</li> <li>Can re-coat at any time</li> </ul>	<ul style="list-style-type: none"> <li>Poor chemical resistance</li> <li>Marginal moisture resistance</li> <li>Short shelf life (about six months for flakes); pay attention to dates when buying premixed shellac in cans, again, avoiding material older than six months</li> </ul>
Satin Lacquer	Dark Walnut/Satin Lacquer	<ul style="list-style-type: none"> <li>Fast drying</li> <li>Easily tinted</li> <li>Easy to repair</li> <li>Good moisture and chemical resistance</li> <li>Great clarity, especially with gloss lacquer; too many coats with satin lacquer will result in a "foggy" appearance</li> <li>Polishes and rubs out to a mirror finish</li> <li>Each new layer "burns" into the previous, forming a chemical bond</li> <li>Lack of a flattening agent in the gloss film means more strength and durability</li> </ul>	<ul style="list-style-type: none"> <li>Harsh solvent content; use in well-ventilated area</li> <li>Fume build-up could result in an explosion if in presence of pilot light, electric motor, etc.</li> <li>For best results, spray equipment is required</li> </ul>
*Gloss Lacquer	*Dark Walnut/Gloss Lacquer		

Note: All samples are from the same red oak board and use the same color stain (Minwax Dark Walnut).

\* Gloss finishes reflect light far more in actual wood than in photographs of the samples.

## Finishing oak for outdoors

Because oak darkens when exposed to light, the initial stain appearance should be a little lighter than the ultimately desired color. Outdoors, it's nearly impossible to prevent the wood from developing a gray patina; use a penetrating oil finish with mildewcides, UV (ultraviolet) inhibitors, and water repellents (two to three wet coats), recoating horizontal surfaces once a year. Recoat the wood twice a year in humid climates. To restore the color in gray wood, sand and then wash it with a deck brightener that contains oxalic acid. Then recoat as described above.



Outdoor woodworking projects, like this porch swing, require finish with UV inhibitors.

## SHOP TIP

### Looking for an oak substitute?

Consider ash. Its deep, open grain and color make for a close match, and it stains and finishes similarly. In the South, hackberry is a popular choice.

Ash

Oak

## Oak afloat

One oak species, live oak (*Quercus virginiana*), does not lose its leaves in the winter. Nor does it neatly classify as a red or white oak. It features grain that looks exceptionally intertwined, plus it's decay- and insect-resistant. The so-called interlocked grain made the wood especially attractive for use in the sides

of sail-powered warships such as the *USS Constitution* ("Old Ironsides"), below. Live oak "absorbed" the impact of cannon balls and resisted splintering into flying daggers of wood. That same interlocked grain, however, while creating a unique appearance, makes machining difficult.



Photo: U.S. Navy

## Buying Smart

What oak costs depends on where you buy it, whether it's white or red, the grade quality, how it's sliced and packaged, how much you buy, and local demand. Keep in mind, too, that flatsawn oak boards cost less to produce than quartersawn, one reason why the latter is scarcer—you won't find it at home centers.

We spot-checked the costs of red and white oak at non-home-center suppliers in Los Angeles; Des Moines, Iowa; and Oxford, Pennsylvania. Surfaced-two-sides (S2S), select grade, 4/4 flatsawn white oak ran \$3.55 a board foot in Los Angeles, surprisingly 25¢ less than the Pennsylvania supplier and 75¢ less than in Des Moines. Quartersawn 4/4 white oak cost \$5.14 per board foot in LA, compared with \$6.05 in Pennsylvania and \$5.92 in Des Moines. Flatsawn 4/4 red oak ran from 15¢ to 72¢ less than flatsawn white oak.

We also compared the cost of 3/4" x 8" x 8' red oak boards sold at brand-name, big-box home centers. Both boards were knot-free and surfaced on four sides (S4S). One was obviously edge-glued to achieve that width and wrapped in cellophane; the other was neither. Each board cost \$33.60 (\$6.34/bd ft), or about double the \$3.40/bd cost of S2S flatsawn red oak in Pennsylvania.)

Translated: It pays to shop around. If you can plane and saw lesser-quality or rough-sawn oak of the right moisture content and work around knots, do it. You'll save big bucks. Quantity buys at a mill also will reap rewards. If you live in a remote area, away from any good supplier, consider mail-order. We received high-quality stock ordering this way, though shipping distances can affect cost. [See "Mail-Order Wood," in issue 161 (February/March 2005) or buy the downloadable article at [woodmagazine.com/mailorderwood](http://woodmagazine.com/mailorderwood).] One last tidbit: If you're going to combine solid stock and plywood in a project, note that home centers typically carry red-oak-veneered plywood. But you'll need to go to a dedicated lumber supplier or mail-order source for white-oak-veneered material. 🌲

Written by **Gene Wengert** and **Jim Harrold**, with **Alan Noel** and **Keith Stephens**; Illustration: **Thomas Rosborough**

# Scrollsawn Safari Puzzle



We're not lion; kids will go ape over this animal scene, straight out of the African savanna. The animals, mountains, and trees are each jigsaw puzzles, and the assembled pieces can be repositioned to create different scenes.

## PROJECT HIGHLIGHTS

- Overall dimensions: 22" long x 5½" deep x 7¾" high.

### Skill Builder

- Learn how to combine different species of wood in a puzzle and maintain a perfect fit between parts.

## Make the parts

**1** Make two photocopies of the combination mountain/animals/trees pattern on the *WOOD Patterns*® insert, one for cutting out the mountain (A, B) and the other for cutting out the animals (C, D, and E) and the trees (H, I). Make one photocopy of the patterns for the remaining animals (F, G). Then cut

blanks for parts A through I [**Materials List**, *next page*]. Finish-sand all the blanks on both sides.

**2** Cut one of the combination patterns along the straight bottom line and about ½" outside the mountain outline. Then, to avoid confusion, trace the dashed cutlines for the mountain base (A) and snowcaps (B) with a highlighter marker. (We traced the cutlines with a blue highlighter and colored in the snowcaps with a yellow highlighter.) Adhere the pattern to the mountain base blank (A) with spray adhesive, aligning the bottom of the pattern with the bottom edge of the blank.

**3** Adhere the snowcaps blank (B) and a ½"-thick scrapwood spacer to the back of the mountain base blank with

double-faced tape [**Photo A**]. (The spacer provides stability when cutting.) Then, with a #2 blade in your scrollsaw, cut the outline of the mountain [**Photo B**].

**4** For a closer fit between the interlocking puzzle parts, switch to a #2/0 blade. Scrollsaw the snowcaps, cutting through the mountain base blank (A) and snowcaps blank (B). Then remove the remaining snowcaps blank and the spacer from the back of the mountain base blank, and finish scrollsawing the mountain base. To ensure a good fit between parts when stack cutting, see the **Shop Tip** on the *next page*.

**5** Cut out the patterns for the animals and trees. Adhere the animal patterns to blanks C, D, E, F, and G, and the tree patterns to the tree trunk blanks

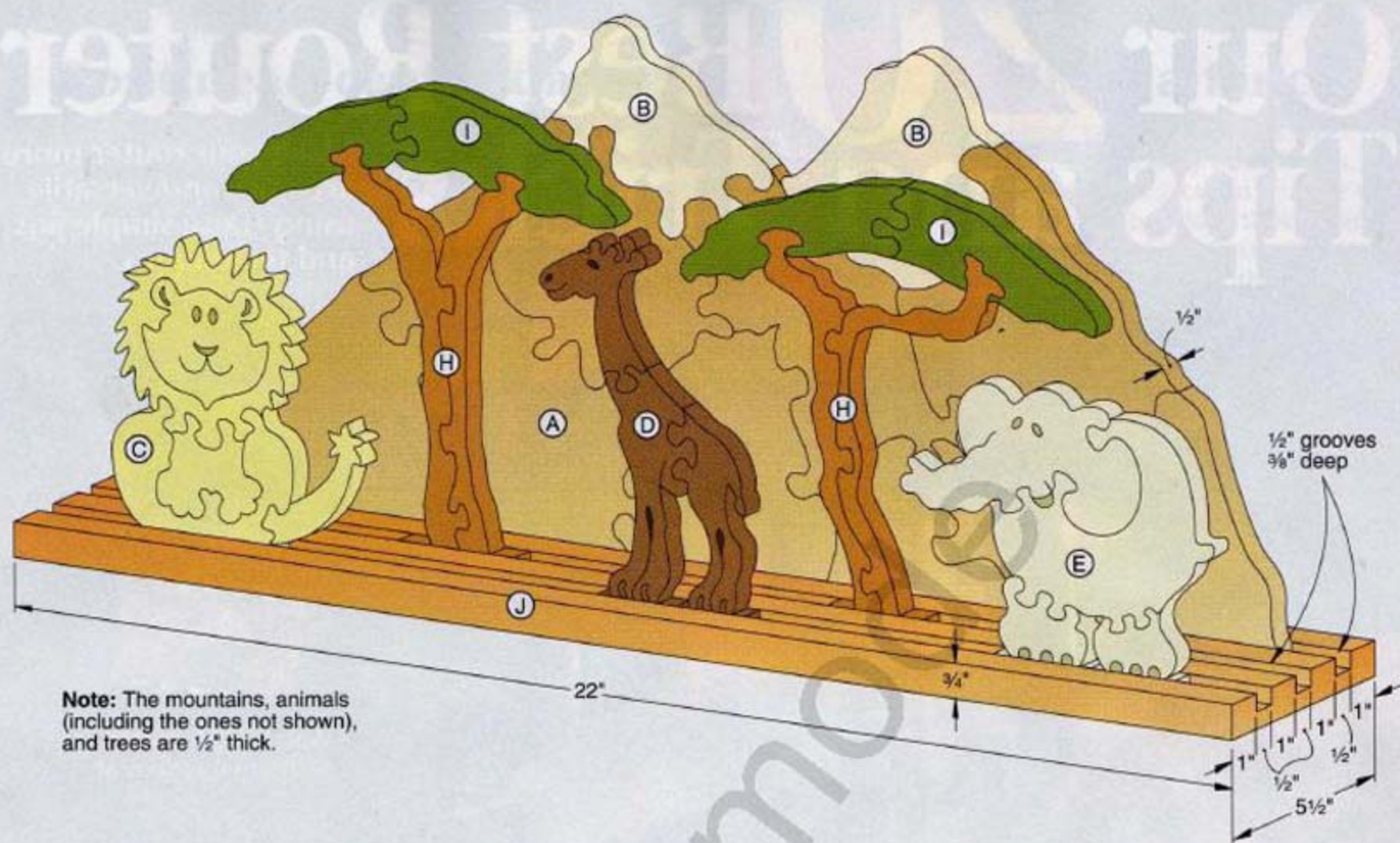

**Note:** The mountains, animals (including the ones not shown), and trees are 1/2" thick.

(H). Then, in a manner similar to cutting the mountain, adhere a treetop blank (I) and a 1/2"-thick scrapwood spacer to the back of each tree trunk blank. Now use a #2 blade to cut the outline of each tree. Drill blade start holes for the inside cuts, switch to a #2/0 blade, and make the interior cuts. When cutting the trees, first stack-cut the treetops, remove the remaining treetop blank and spacer from each tree trunk blank, and then cut the tree trunks.

**6** Cut the base (J) to size. Install a 1/2" dado blade in your tablesaw, and cut

grooves to hold the mountain, animals, and trees, where shown on the drawing above. Finish-sand the base.

### Finish and assemble

**1** Examine all the parts, and finish-sand where needed.

**2** Apply a clear finish. (We applied three coats of aerosol satin lacquer, lightly sanding with 320-grit sandpaper between coats.)

Written by **Jan Svec** with **Chuck Hedlund**

Project design: **Kevin Boyle**

Illustrations: **Roxanne LeMoine; Lorna Johnson**

## SHOP TIP

### How to ensure a first-class fit between puzzle parts

Scrollsawing thick material, such as the two 1/2" layers stack-cut to form the mountain snowcaps and the treetops, can cause a fine blade to distort, making a poor fit between the parts. To prevent this, use a sharp blade and slow your feed rate.

## Materials List

Part	BLANK SIZE			Matl.	Qty.
	T	W	L		
A mountain base	1/2"	7"	15"	O	1
B snowcaps	1/2"	4 1/4"	8"	A	1
C lion	1/2"	4"	4 1/4"	YH	1
D giraffe	1/2"	3 3/4"	5"	L	1
E elephant	1/2"	4"	4 3/4"	A	1
F zebra	1/2"	2 3/4"	4 3/4"	YP	1
G rhinoceros	1/2"	3"	4 3/4"	W	1
H tree trunks	1/2"	3 3/4"	6"	M	2
I treetops	1/2"	2"	6"	GP	2
J base	3/4"	5 1/2"	22"	C	1

**Materials key:** O—red oak, A—aspens, YH—yellowheart, L—lacewood, YP—Southern yellow pine, W—walnut, M—mahogany, GP—green poplar, C—cherry.

**Supplies:** Double-faced tape, spray adhesive.

**Blades and bit:** #2 and #2/0 scrollsaw blades, stack dado set.

### STACK-CUT THE MOUNTAIN BASE AND SNOWCAPS

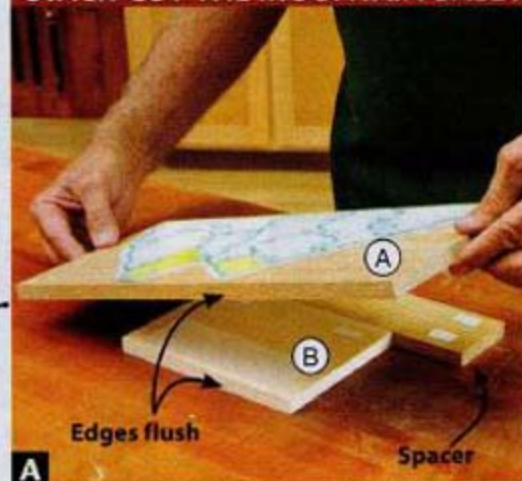

**A** Adhere the snowcaps blank (B) to the mountain base blank (A), flush at the top, with blank B centered on the pattern snowcaps.



**B** Stack-cut the outline of the mountain, cutting through both the mountain base blank (A) and the snowcaps blank (B).

# Our **20** Best Router Tips and Tricks

Make your router more accurate and versatile using these simple jigs and techniques.



Watch FREE router technique videos at [woodmagazine.com/routertips](http://woodmagazine.com/routertips)

See Tip #9 to learn more about this slick way to cleanly and quickly trim edging.



## 1 Rout dead-center dados

This guide helps you center a straight bit of any width on the centerline of your dado. Start by ripping two strips from  $\frac{3}{4}$ " plywood or medium-density fiberboard, to the dimensions shown *below*. With the edges butted tightly together, connect the pieces with hinges. Next, mount in your router a straight bit the same diameter as the thickness of the stock going into the dado. Adjust the bit for the depth of the dado.

Now, mark the center of each dado on your workpiece. Align the flip-up gauge edge with a dado mark, and square up the jig to the workpiece, as shown at *right top*. Then clamp it in place.

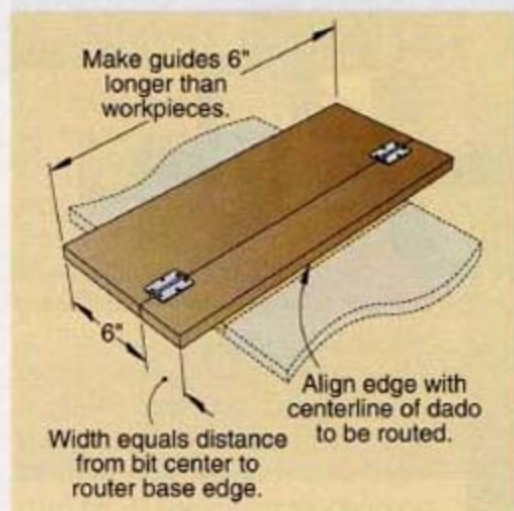

Flip the gauge up over the fence and use the fence edge to guide the router as you dado-cut, as shown at *bottom*.



## 2 Reset a fence

Two-piece rail-and-stile bits use the exact same fence setup for both bits. But that perfect fence location must be disturbed to swap bits. Save time resetting your router-table fence flush with the bit bearing and parallel to the miter slot with this handy gauge. After adjusting the fence flush with the bit bearing and parallel to the miter slot, install the jig in the miter slot. Slide the gauge blocks up to the fence, and tighten the wing nuts to secure the blocks. Then remove the jig, and make your first set of cuts. After you move the fence to change bits, remount the jig in the miter slot. Slide the fence against the blocks, and tighten it in place. If your router table lacks a miter slot, lengthen the gauge blocks so the hardwood runner rides against the front edge of the tabletop.



## 3 A pair of paths to precise plunges

You can fuss with rulers and depth gauges all you want, but here are two quick and easy ways to precisely set your plunge router cutting depth.

The method shown on the *right* uses different drill bit thicknesses to exactly set a router's plunge depth. First, place the router on your bench and plunge the bit until it touches the benchtop. Then lock it in place. Loosen the depth stop-rod, and sandwich a drill bit of a diameter equal to the plunge depth between the turret stop and rod. Then tighten the rod in place. Unlock the plunge mechanism, and you're ready to plunge into your project.

The method at *far right* uses spacers planed to the same thickness as the depth of your plunge cuts. Place the router on a pair of spacers, and plunge the bit until it touches the benchtop. Then lower and tighten the stop-rod.

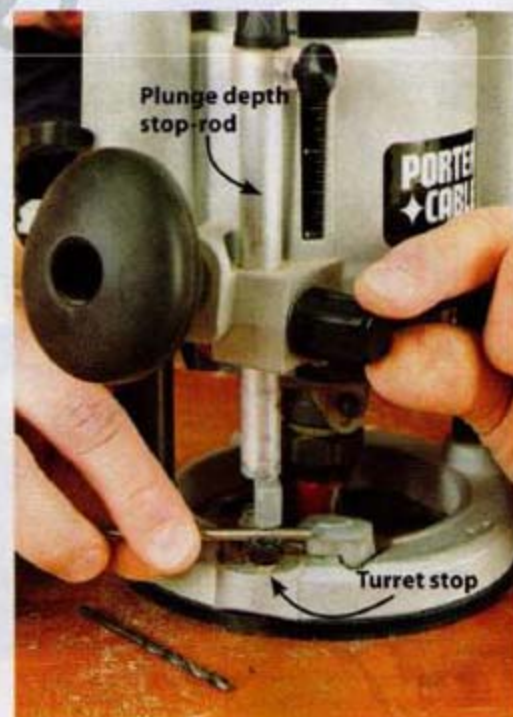

## 4 Tape your way to tighter dados

Adjusting a jig or straightedge to widen a dado just a hair can create more problems than it solves. Instead, leave your guide in place and add strips of tape along the router base edge, as shown *below*. That nudges the bit away from the guide when you recut. Four layers of blue painter's tape equals about  $\frac{1}{64}$ ".



## 5 Gauge blocks simplify bit setups

Have you ever painstakingly set a bit height, only to find that you needed to return to it later? Making individual gauge blocks for rail-and-stile, raised-panel, finger-joint, and profiling bits saves setup time. You can rout them from medium-density fiberboard or hardwood, but ultra-high molecular-weight (UHMW) polyethylene, shown *below*, makes a more stable block. (Assortment no. 143291, \$12, from Woodcraft, 800-225-1153 or woodcraft.com.)

From stock planed to the same thickness as your project parts, cut blanks at least 4" wide and 6-8" long. Next, set up the bit in the router table and make test cuts in scrap to fine-tune the height. After routing project parts, rout the same profile on a gauge-block blank.

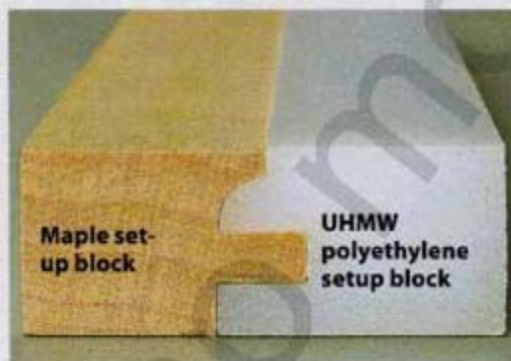

Repeat for the mating bit, if needed. Then rip the gauge blocks to about  $1\frac{1}{2}$ " wide, and label them with the bit profile and stock thickness.

To use the gauge blocks, chuck a bit into a table-mounted router and raise it to roughly the correct height. Place the gauge block with the mating profile beside the bit. Then raise or lower the bit until it slides into the routed profile on the block, as shown *below*, and lock the height. You'll still need to test-cut scrap for a dead-on fit, but the gauge blocks will make that go a lot faster.

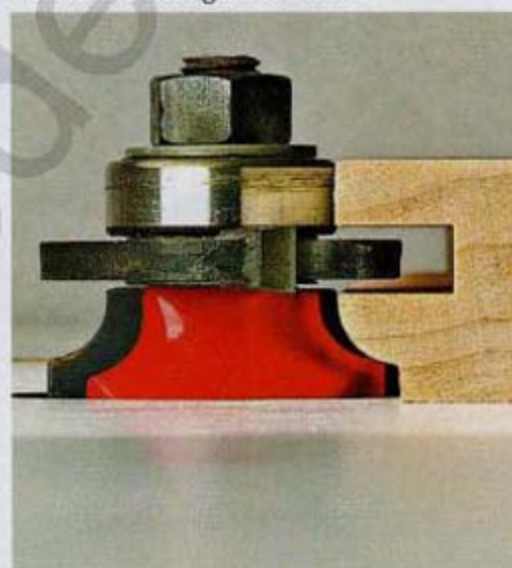

## 6 Parallel passes

Whether you're routing dovetail slots, as shown at *right*, or T-slotted wall storage system panels, here's a time-saving jig for you. It indexes from the previously routed slot to ensure evenly spaced dados, dovetails, and grooves.

From scrap  $\frac{1}{2}$ " plywood, cut a subbase to fit your router and project. Then rout a dado on the subbase bottom where the distance between the dado and the bit equals the spacing between the slots. Make the dado as wide as the bit profile at the workpiece surface. Attach a matching hardwood guide in the dado. For grooves deeper than  $\frac{1}{4}$ ", make progressively deeper cuts. For dovetails, rout first with a straight bit, and then finish with a dovetail bit for efficient chip removal.

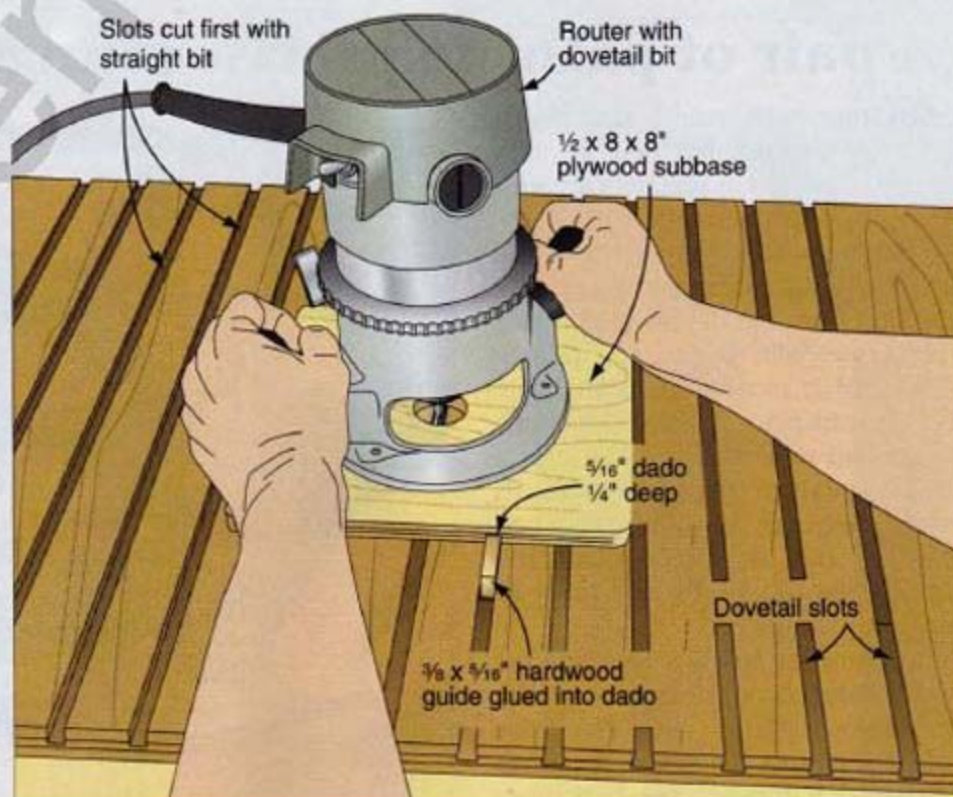

# KEEP CUTS UNDER CONTROL

## 7 Rout stopped cuts with stopblocks

Edge cuts, such as chamfers, and surface profiles, such as flutes, sometimes need to start and stop precisely and uniformly. That's the time to use simple, customized stopblocks to control where the profile starts and stops on each workpiece. Measure from the point where the cut will stop to the end of the workpiece, subtract the bearing radius, and cut the stopblock to that length from scrap at least  $\frac{3}{4}$ " thick. Clamp the stopblock to the edge of the workpiece as shown.

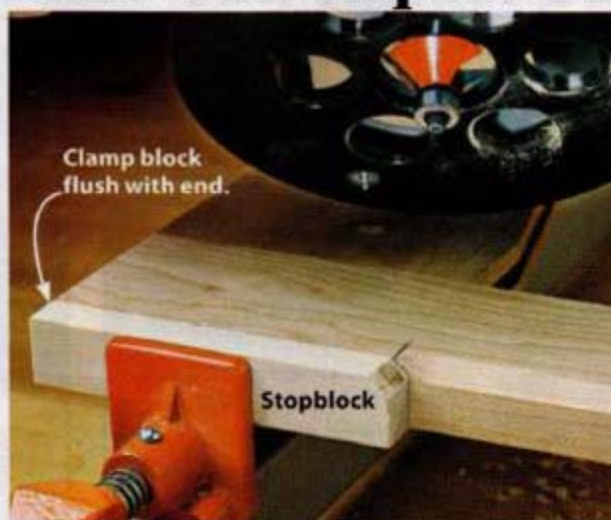

## 8 Get a grip on small parts

Small parts can drop through oversize router-table inserts or instantly tug fingers into the bit. To solve both problems, first drill a hole slightly larger than the bit diameter in a piece of  $\frac{1}{4}$ " plywood, and clamp it to the router-table top for near-zero-clearance support. Then keep your fingers safe by gripping the part with a handscrew. The jaws of these clamps can be angled to firmly grasp odd-size parts and hold them flat against the zero-clearance top.



## 9 Shelf-help for trimming edges

Perching a router on a shelf edge to flush-trim solid-wood edges can turn ugly if your machine tips. Give it stability by clamping together the shelves on edge. Cut spacer blocks from 2x4 scrap and place them between the shelves at both ends. Then clamp the spacers and shelves together. (We clamped one of those clamps to the bench for added stability.) Then rout each edge with a flush-trim bit. If the router wobbles on the edges of the outside shelves, move those pieces to the inside, reclamp, and finish routing.



## 11 A starter pin keeps fingers safe

The toughest part of freehand routing is easing the workpiece against the bit. To help you guide parts safely, make a starter pin from a hardwood, brass, or aluminum rod, and securely mount it to the table about 2" from the bit. Brace the workpiece against the starter pin; then slowly rotate it into the bit and bearing. Grip the workpiece close to the pin, and use the above technique for small parts.

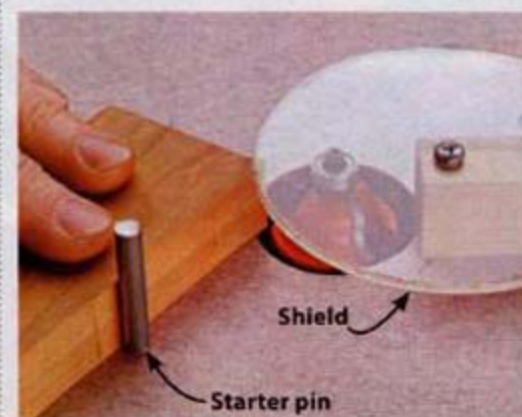

## 10 Rout round-overs, not tip-overs

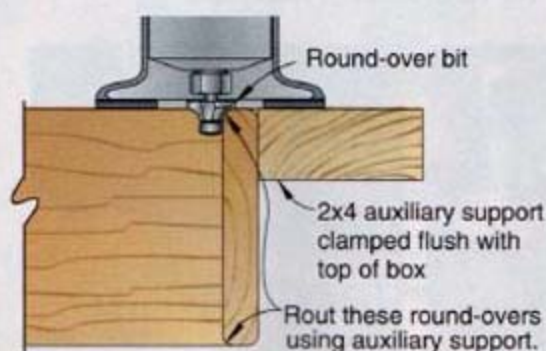
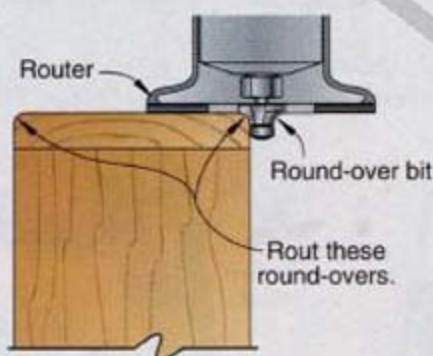

A tipping router can ruin the edge of a finished project, so keep that base stable. If you need to round over the outside edges of an assembled box, tip the project on edge and use the front, back, and

sides to support the router base, as shown *above left*. To rout inside round-overs with equal ease, clamp a 2x4 auxiliary support onto the outside surfaces, as shown *above*.

## 12 Enlarge holes in two easy steps

Maybe you need to enlarge a hole, or make a dead-on round hole larger than your largest Forstner bit. Do either using a rabbeting and a flush-trim bit.

To enlarge a hole's radius by  $\frac{1}{4}$ ", first rout a  $\frac{1}{4}$ "-deep rabbet the width of your cutter while keeping the bearing against the edge of the hole. This creates the "step" shown at *near right*.

Next, turn the workpiece upside down and install a flush-trim bit. Adjust the cutting depth so the bearing rides along the cut made by the rabbeting bit and rout away the step, as shown at *far right*.

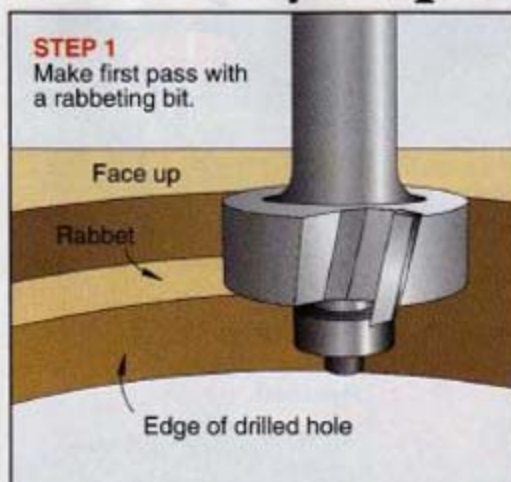

## 13 Master complicated curves

Templates needn't always follow straight lines and simple curves. They also handle more complex shapes as long as the template corners aren't tighter than the diameter of your router guide bushing.

This reversible template lets you rout mirror-image patterns, as on this shelf bracket. With a different pattern, you could rout matching tambour-door tracks in the inside faces of a rolltop desk or a countertop kitchen appliance holder. There's only one requirement: The workpiece should have at least one straight edge to align the template.

Make templates from  $\frac{1}{4}$ " plywood or veneered medium-density fiberboard, leaving an extra  $\frac{3}{4}$ " of material on two adjacent edges. Size and shape the template to allow for the diameter of the guide bushing. With the template in position on the workpiece, trace the reference edges of the workpiece onto the template bottom.

Then flip the template over and, along each line, drill two  $\frac{1}{4}$ " holes so their edges just touch the line. Then cut four  $\frac{3}{4}$ " lengths of  $\frac{1}{4}$ " dowel and insert them into the four holes. Dowels should fit snugly enough that they don't fall out, but not too snug to tap through the template. For a tight fit, moisten dowels and allow them to dry before inserting them in the template.

Next, choose a bit that creates the pattern you want, and attach a guide bushing sized to accommodate the router bit diameter and the desired offset from the template. Tap the dowels flush with one side of the template before you clamp on the template so the dowels register against the workpiece. Rout the pattern, as shown *below left*. Then flip the template over, tap the dowels flush with the opposite surface, as shown *below right*, and rout the mirror version of the first path.

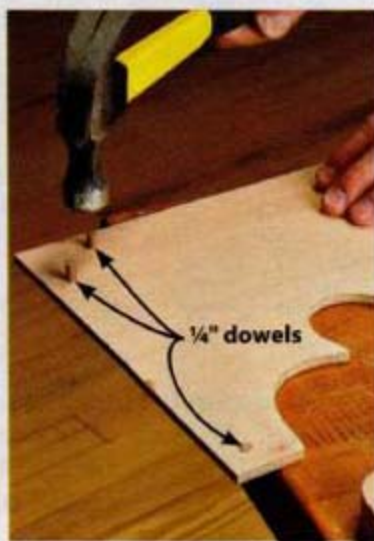

## 14 Rout corners consistently

Rounding over corners by hand-sanding produces uneven results. Instead, use a round-over bit with the radius you want for your corners. With the bit chucked on a table-mounted router, raise the bit height until it cuts a quarter-round profile in scrap without leaving a shoulder. Then position the fence flush with the bit pilot bearing. To prevent chip-out and keep the frame square to the fence and router-table top, clamp it to a 2x4 backer block, as shown *below*.



## 15 To wipe out tear-out, call for backup

Backer blocks not only reinforce routable cuts, they also double as miter gauges for keeping parts perpendicular to the fence more reliably than a miter gauge. Use the drawing below to assemble a backer block from  $\frac{3}{4}$ " scrap sheet goods,

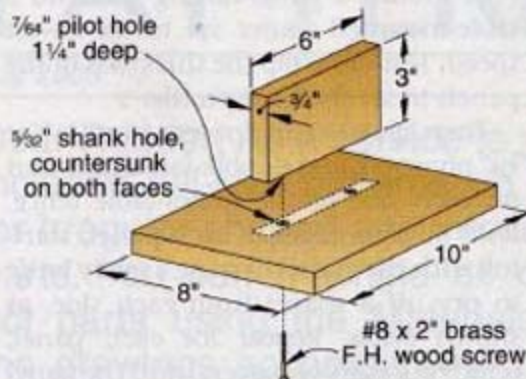

or customize it to suit your needs. One advantage of a base this size is that you can trim away the routed edges and use the block again with a different profile.

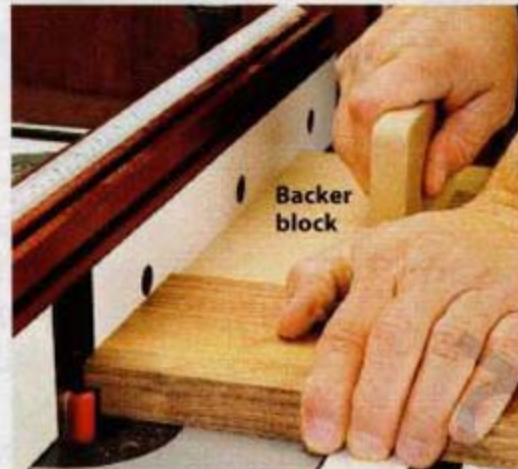

You also can modify the block to cut tenons on end by gluing on a vertical support to steady the workpiece and a heel to push it into the bit.

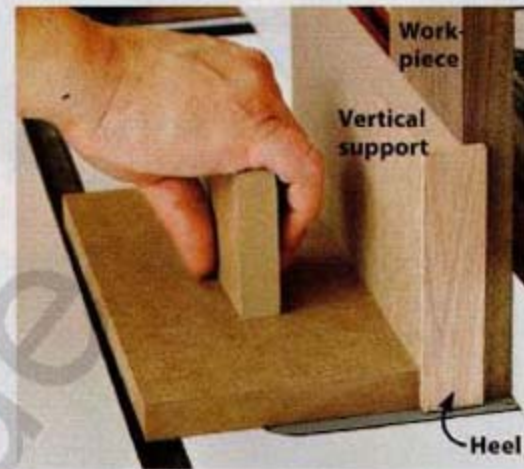

## 16 Rout precise shelf-pin holes

The downside to making adjustable shelving is drilling the shelf-pin holes consistently. With this template, however, you can bore clean, precise holes time after time using a plunge router with a guide bushing and straight bit.

Make the template from a strip of  $\frac{1}{4}$ " tempered hardboard that's smooth on both sides. Vary the strip width and length to suit the placement of your shelf-pin holes. For example, the holes in the 3"-wide template below are offset to rout shelf-pin holes  $1\frac{1}{4}$ " from the shelf edge on one side and  $1\frac{3}{4}$ " on the other. Then use a drill press with a brad-point bit to bore evenly spaced  $\frac{3}{8}$ " holes. (If

you're off a hair, referencing the template from the same end of the workpiece every time ensures stable shelves.) Then clamp the template onto the case side.

Next, mount a  $\frac{3}{8}$ " guide bushing onto the router base. (If the bushing extends past the template bottom, file or grind it flush.) Then install a  $\frac{1}{4}$ " straight bit into your router, and set the plunge depth to allow for the thickness of the jig.

At each hole in the template, insert the guide bushing and plunge-cut a hole. Then move to the next hole and repeat until you're finished.

To see a video on using this template, visit [woodmagazine.com/shelfholes](http://woodmagazine.com/shelfholes).

## 17 Here's an idea you can copy

Mounting jigs or subbases onto a router, as shown in **Tip 6**, requires precise mounting holes. Make that job easier by photocopying the router base and using the copy to mark and drill mounting holes. Check the copy size against the base size in case the copier is off slightly, and reduce or enlarge it as needed. If you have a computer scanner, you also can scan the base and file the scan for future printing.

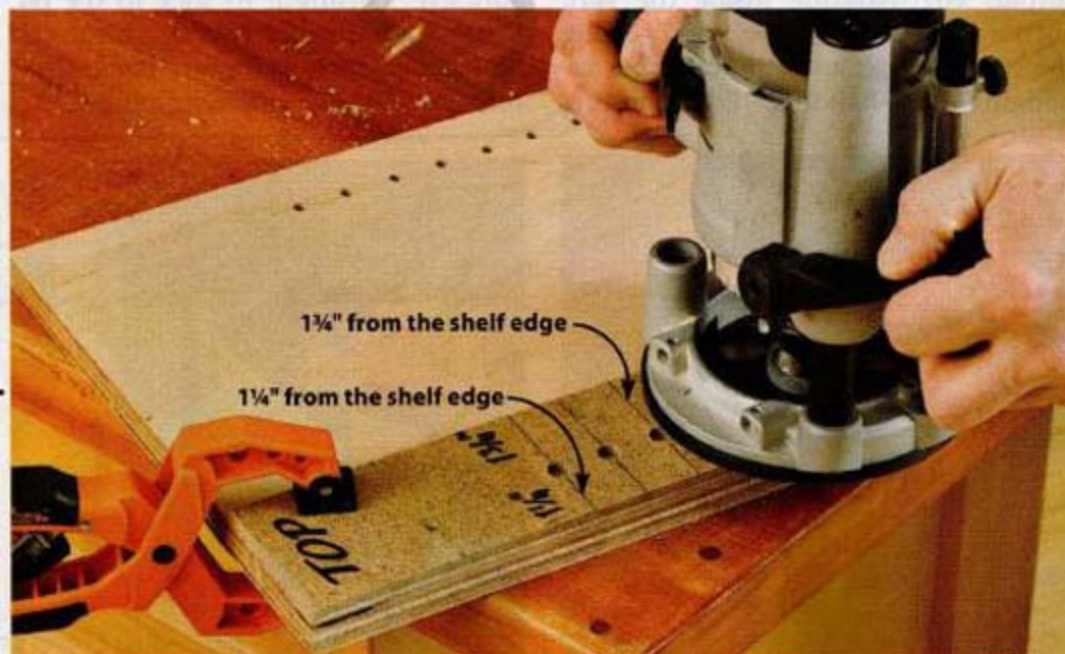

## 18 Joint boards on a router table

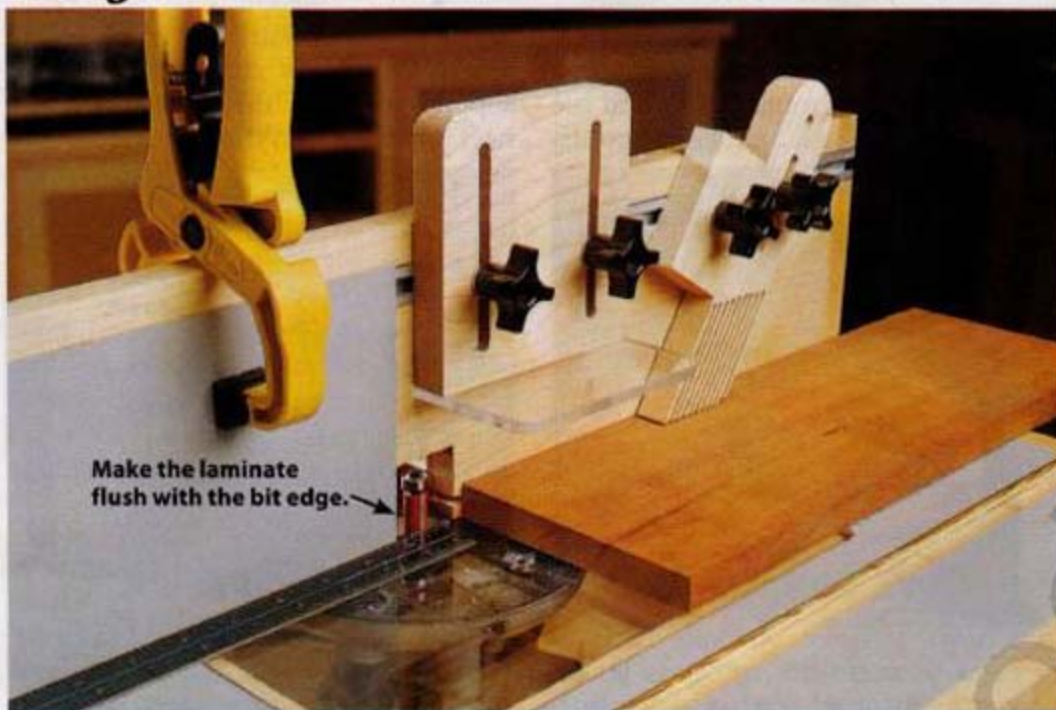

No jointer? No problem. Plastic laminate clamped to the outfeed side of your router-table fence works the same as the outfeed table on a jointer. Cut laminate to fit the left side of the fence; then sand a chamfer on the edge nearest the bit to avoid snagging your workpiece.

Use a straightedge to adjust the fence until the laminate is flush with the cut-

ting edge of your installed flush-trim bit raised to cut the full width of the workpiece edge. Start the pass by pressing the workpiece against the right half of the fence; then slide it from right to left. As it clears the bit, shift pressure to your left hand to press the trimmed portion against the laminate to finish the cut, which trims about  $\frac{1}{16}$ " with each pass.

## 19 Spacers divide raised panel cuts

Routing raised panel edges in one pass produces tear-out and it's risky. Spacers taped to a router-table fence let you rout gradually without constant adjustments. First mount a panel-raising bit onto a table-mounted router set to its lowest speed. Test-cut scrap the thickness of the panels to set the final profile.

Then make eight spacers from  $\frac{1}{8}$ " or  $\frac{3}{16}$ " plywood, and double-faced tape four on each side of the router-table fence. Rout all four edges of each panel, starting with the ends; then use a putty knife to pry off a spacer from each side, as shown *below*. Repeat for each panel, removing pairs of spacers until the panel rides against the fence on the final pass.

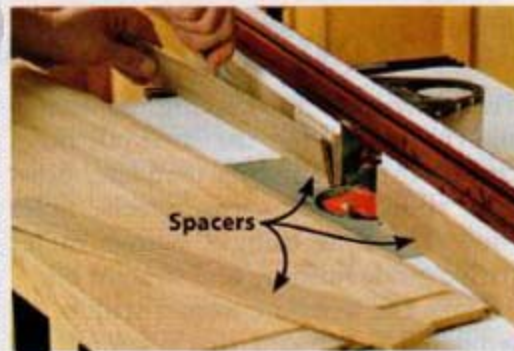

## 20 Rout away extra edge-banding

Balancing a router with a flush-trim bit along a workpiece edge as you remove excess iron-on edge-banding can ruin a shelf with the slightest tip. But a router with a  $\frac{1}{4}$ " straight bit and this jig trims edging without risking gouges. To make this jig, cut an 8" square base from  $\frac{1}{2}$ "-thick medium-density fiberboard (MDF) or plywood. Then cut a  $\frac{1}{4}$ "-deep kerf centered on the bottom. From  $\frac{3}{4}$ " plywood or MDF, cut a  $3\frac{15}{16} \times 8$ " fence, and glue it to the base flush with the kerf, as shown at *near right*. Using a  $\frac{3}{4}$ " plywood scrap to stabilize the base, drill a  $\frac{3}{4}$ " centered hole with a Forstner bit.

Next, insert a  $\frac{1}{4}$ " straight bit in your router. With the bit centered in the hole (and the kerf), mount the router to the jig with double-faced tape. Then adjust the bit depth so the tip comes to just below the bottom surface of the base. Test the setting on plywood scrap to make certain the bit doesn't leave score marks on the surface.

To trim edge-banding, clamp the workpiece into position, as shown *below right*. Push the jig base firmly against the workpiece surface and edge with the surplus edge-banding inside the kerf. Turn on the router, slide the jig along the banded edge, and trim off the overhanging edge-banding. Edge-banding

still proud of the surface can be sanded away with 180-grit abrasive.

The heat from the spinning bit may reactivate some of the edge-banding adhesive, causing it to stick to the bit. Remove it immediately with a blade and bit cleaner, such as Empire Blade Saver (866-700-5823 or [empiremfg.com](http://empiremfg.com)). 🌱

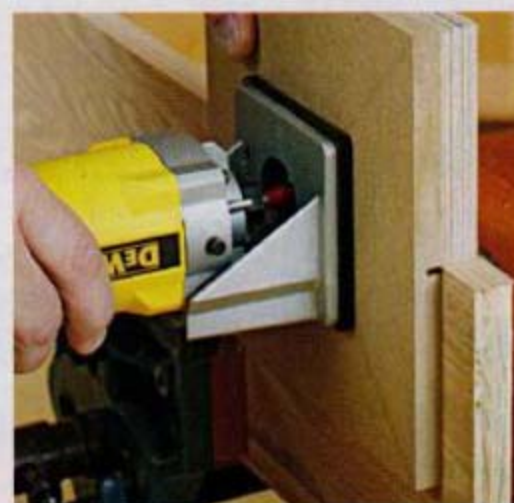
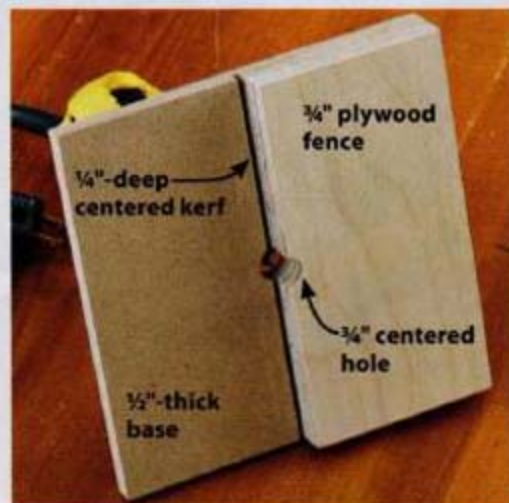

Better Homes and Gardens.

# WOOD PATTERNS

July 2008

Issue 184

Dear Reader: As a service to you, we've included full-size patterns on this insert for irregular shaped and intricate project parts. You can machine all other project parts using the Materials List and the drawings accompanying the project you're building.

© Copyright Meredith Corporation, 2008. All rights reserved. Printed in the U.S.A. Meredith Corp., the publisher of WOOD Patterns®, allows the purchaser of this pattern insert to photocopy these patterns solely for personal use. Any other reproduction of these patterns is strictly prohibited.

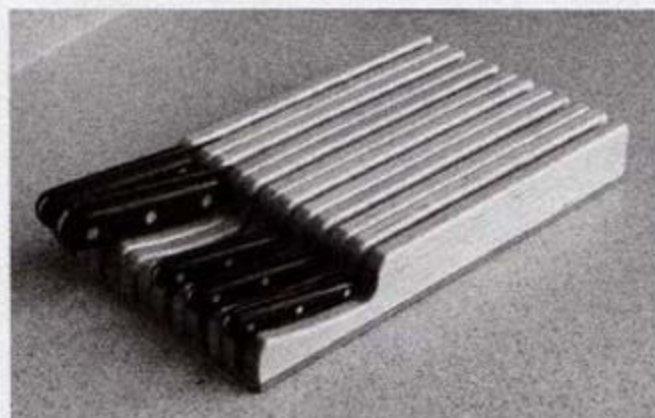

Knife Holder Page 94

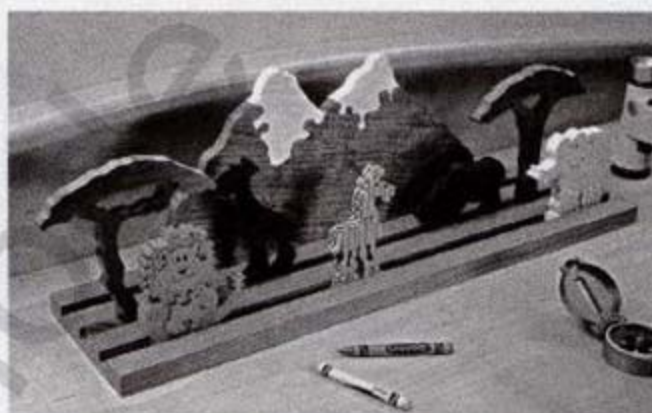

Safari Puzzle Page 44

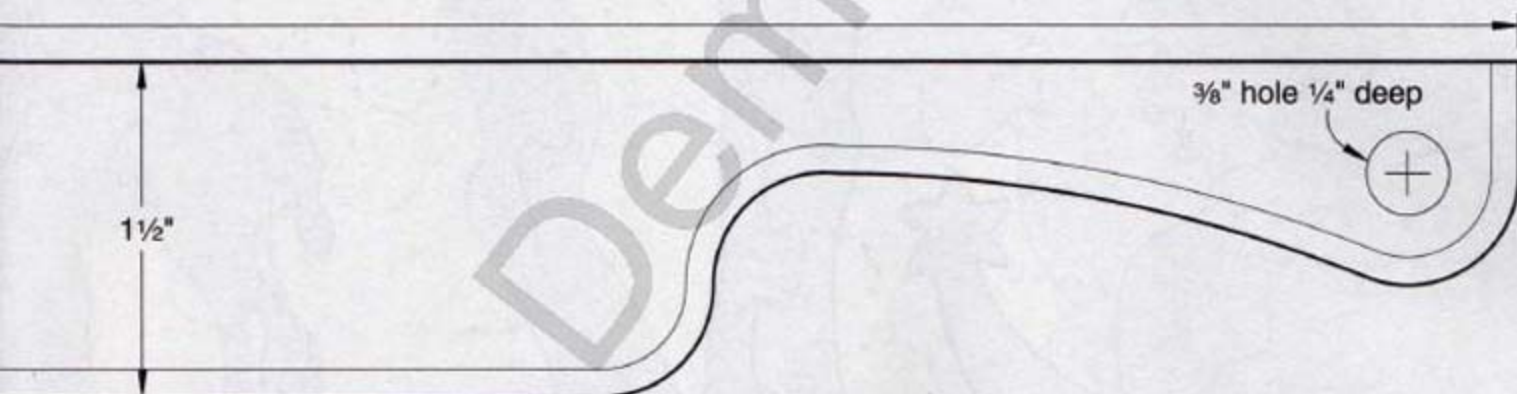

Knife Holder  
Page 94

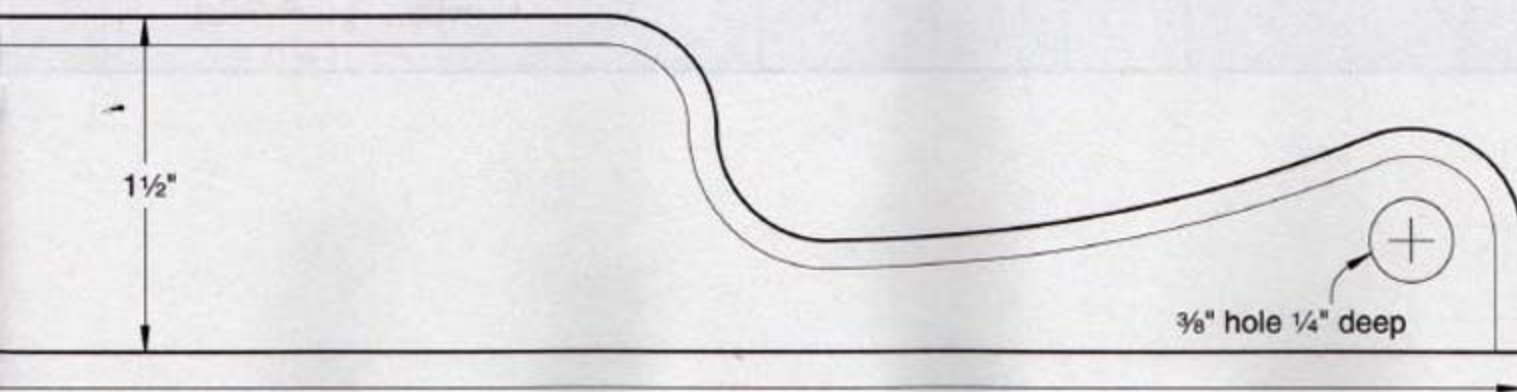

Safari Puzzle  
Page 44

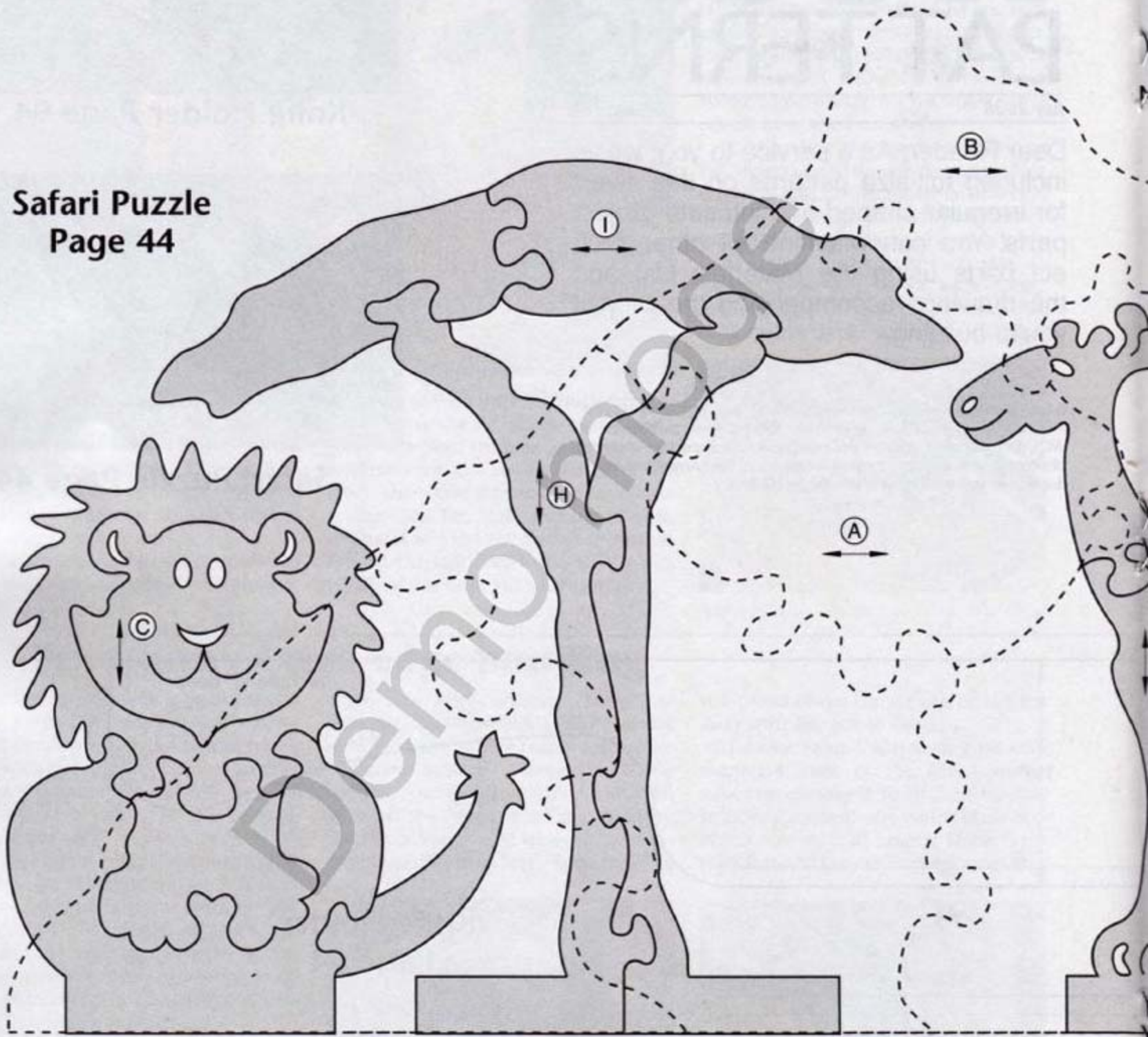



Note: Grain direction

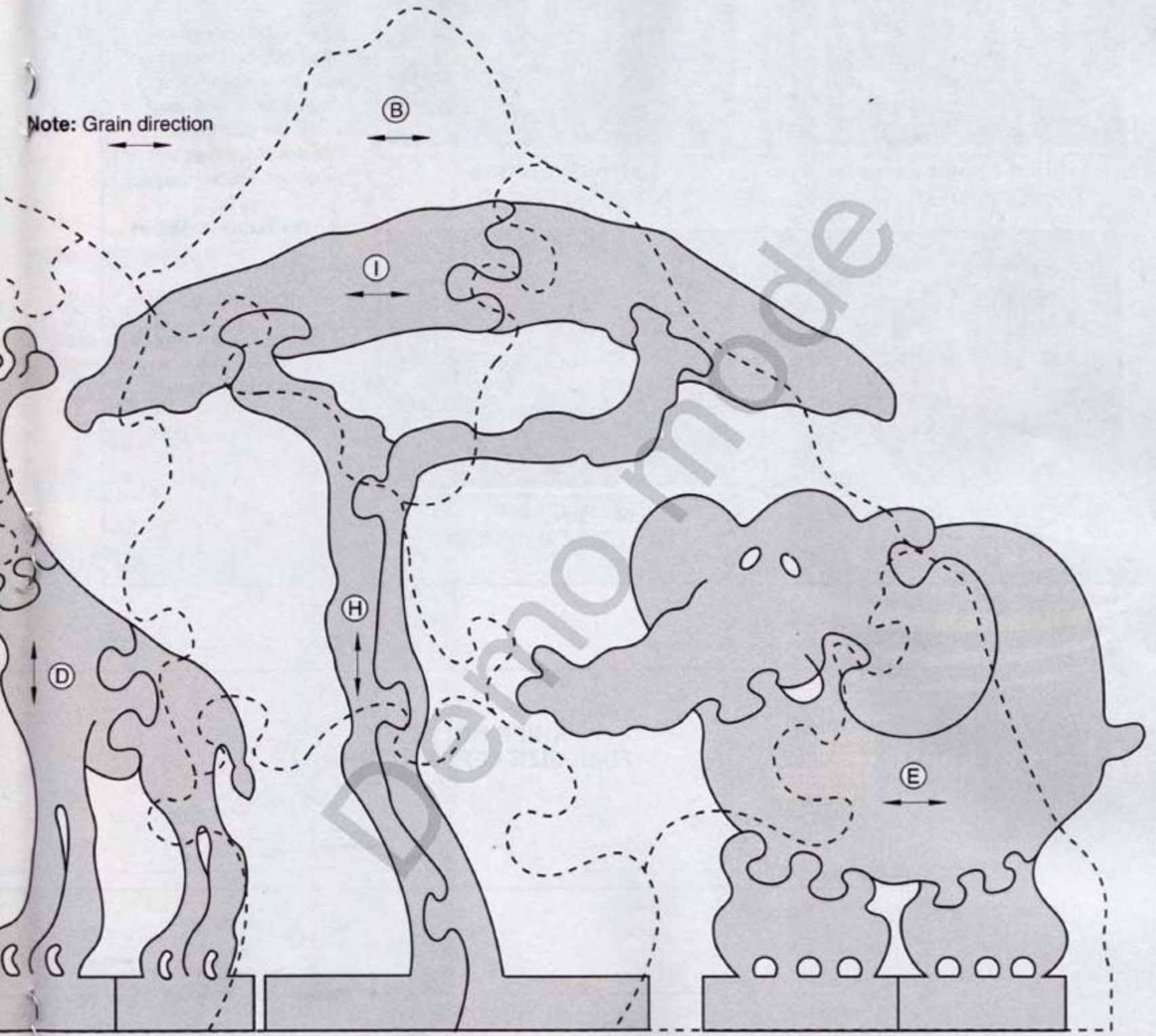

# All-Time Favorite Outdoor Furniture Plans



**Build-to-Suit Pergola**  
Plan DP-00327 \$8.75



**Arched Footbridge**  
Plan DP-00139 \$8.95

from the editors of  
**WOOD**® magazine

Download any of these  
woodworking plans, or  
have them mailed directly  
to you for an additional  
\$3 per plan (S+H).

To download the plans  
or to view a larger image,  
go to

[woodmagazine.com/plans](http://woodmagazine.com/plans)

Call toll free

**1-888-636-4478**

for paper-plan  
credit card orders.



**Comfy Classic Garden Bench**  
Plan DP-00512 \$9.95



**Easy Glider**  
Plan DP-00305 \$8.95



# Built to Last A Lifetime.

## What Dust Collection Should Be...

*"Wow! This is what made in the U.S.A. used to be... solid... well-built... and man, does it pull dust! Thank you for a great product!"*

- J. H. - Michigan



**Dust Collection.  
It's All We Do.**



**Made in the USA**

Inventing award-winning dust collection systems & components for 15 years.

See our customer satisfaction surveys on our web site.

*Order Online!*

**[www.oneida-air.com](http://www.oneida-air.com)**

*Call Today for FREE Catalog!*

**1.800.732.4065**

See us at IWF 2008  
Booth # 6669



## BASIC-BUILT

GREAT PROJECTS. SIMPLE TOOLS.

Basic-Built projects require only beginning skills and a limited number of inexpensive tools and materials. For more information, go to [woodmagazine.com/basicbuilt](http://woodmagazine.com/basicbuilt).

# Mission End Table

Build this super-simple yet stylish project using only five power tools!

**Y**ou'll find this compact end table handy for almost any room in the house. Put a reading lamp on it in the den or park it next to your lounge to hold popcorn while you watch a movie in the family room. And even better than its versatility, you built it.

### Start with the base parts

**1** Cut the legs (A) to the size listed [Materials List, page 62, Photo A].

**2** Mark four centerpoints on each leg for the mounting holes and lay out the  $\frac{3}{8} \times \frac{3}{8}$ " mortises around the lower pair of centerpoints, where dimensioned [Drawing 1]. Using a  $\frac{3}{8}$ " brad-point bit to avoid tear-out, drill a  $\frac{3}{8}$ "-deep hole at each centerpoint. For consistent hole depth, wrap a piece of masking tape around the bit for a visual depth stop. Then, drill a  $\frac{1}{2}$ " shank hole centered in each hole. Now, square the bottom holes

to receive the mortise plugs (G) [Photo B]. As an alternative to the mortised holes, you can plug them with  $\frac{3}{8}$ " plugs as for the top holes.

**3** Cut the long rails (B), short rails (C), and cleats (D) to the sizes listed, noting that the short rails and cleats are the same size.

**4** Mark centerpoints for the mounting holes on the long rails (B) and short rails (C), where shown. Drill  $\frac{1}{8}$ " holes

## PROJECT HIGHLIGHTS

- Overall dimensions: 26" diameter x 25 $\frac{3}{4}$ " high.
- Materials needed:  $\frac{3}{4}$ " red oak and a  $\frac{3}{8}$ "-diameter oak dowel. We used select-grade 1x3, 1x4, and 1x6 boards ( $\frac{3}{4}$ x2 $\frac{1}{2}$ ",  $\frac{3}{4}$ x3 $\frac{1}{2}$ ", and  $\frac{3}{4}$ x5 $\frac{1}{2}$ " actual), sanded smooth on both faces and edges, from our local home center.
- Power tools needed: a tablesaw (a benchtop type works fine), drill, jigsaw, plunge router, and random-orbit sander.

### Skill Builders

- Learn how to conceal mounting screws with decorative square plugs and how to safely machine the plugs using your tablesaw.
- Discover an easy way to glue up flat panels using just two clamps and a simple jig made from a 2x4.

## 1 EXPLODED VIEW

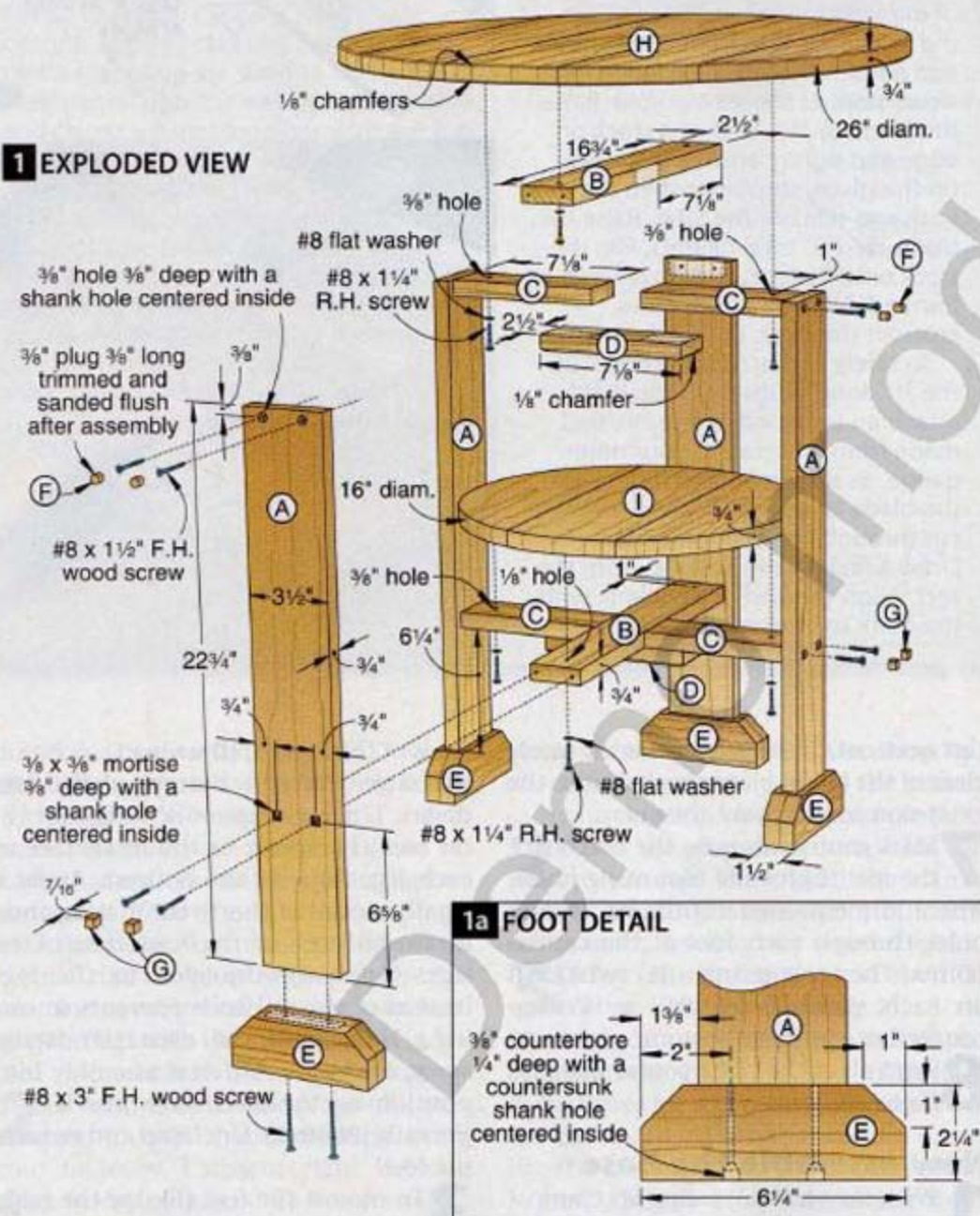

### 1a FOOT DETAIL

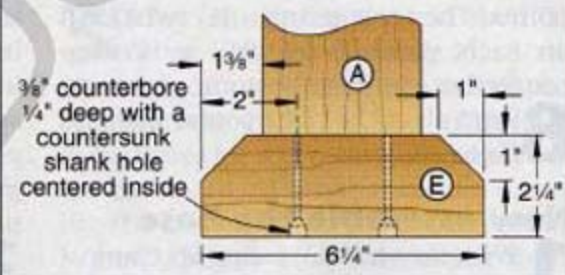

through the long rails and  $\frac{3}{8}$ " holes through the short rails at the center-points. The  $\frac{3}{8}$ " holes provide clearance for the screws to allow expansion and contraction of the top (H) and shelf (I).

**5** Glue the long rails (B), short rails (C), and cleats (D) together in the configuration shown [Drawing 1, Photo C], forming two assemblies. Then, rout or sand a  $\frac{1}{8}$ " chamfer across the ends and along the edges of the cleats.

**6** To form the laminated feet (E), rip and crosscut eight 2 $\frac{1}{4}$ x6 $\frac{1}{4}$ " pieces from  $\frac{3}{4}$ " stock. Laminate the pieces together to form four 1 $\frac{1}{2}$ "-thick feet. Next, on one foot, lay out the 45° miter at one end, where dimensioned [Drawing 1a]. Position a stopblock on your miter-gauge extension and clamp it in place to make miter cuts on both ends of each foot. Cut one end on each part, then flip the part end for end to make

## CUT THE LEGS TO LENGTH

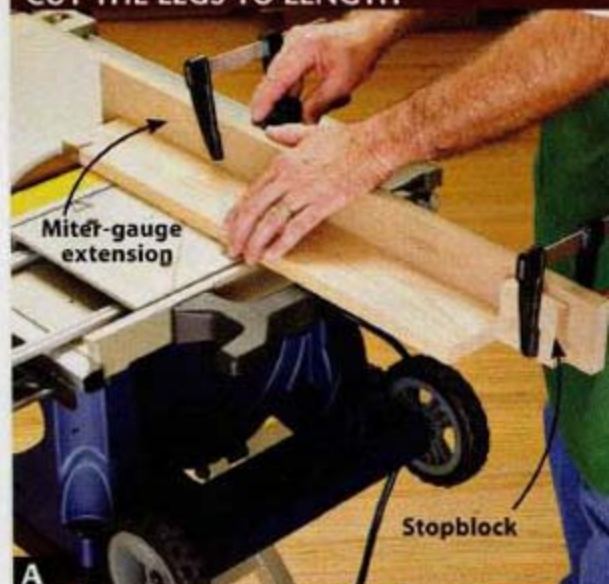

Crosscut the legs (A) to 22 $\frac{3}{4}$ " long. To ensure identical lengths, use a stopblock attached to an extension on your miter gauge.

## SQUARE THE PLUG MORTISES

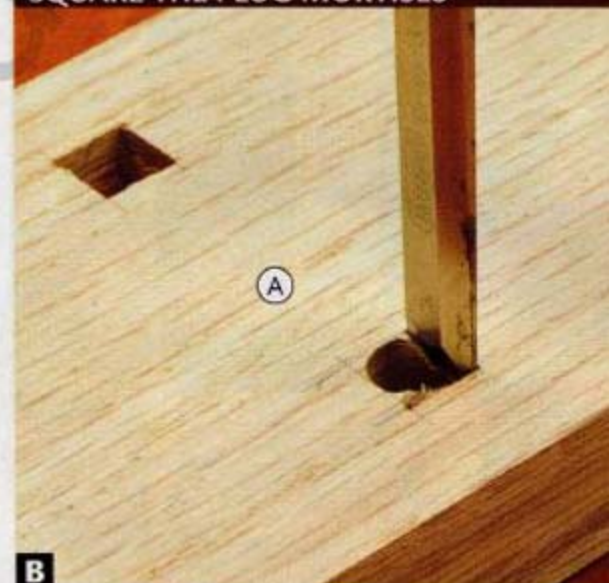

Using a sharp  $\frac{3}{8}$ " chisel, square the lower pair of  $\frac{3}{8}$ " holes in the legs (A) to form the  $\frac{3}{8}$ "-deep openings for the mortise plugs (G).

## ASSEMBLE THE RAILS AND CLEAT

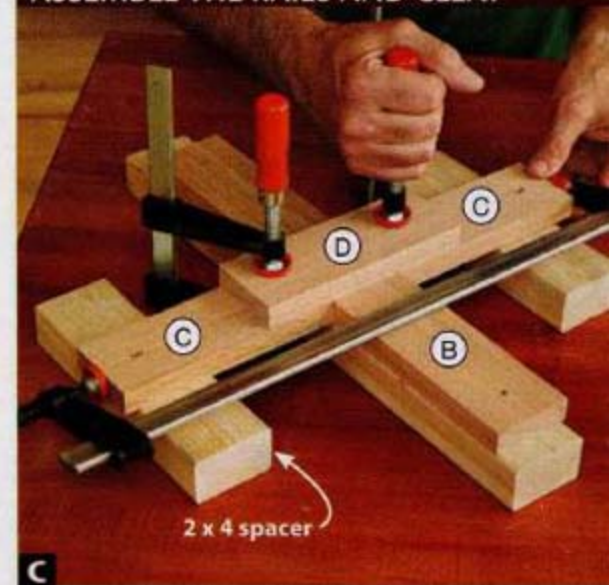

Glue and clamp the short rails (C) and cleat (D), centered, to the long rail (B). Place 2x4 spacers under the parts for clamp clearance.

## MOUNT THE LEGS

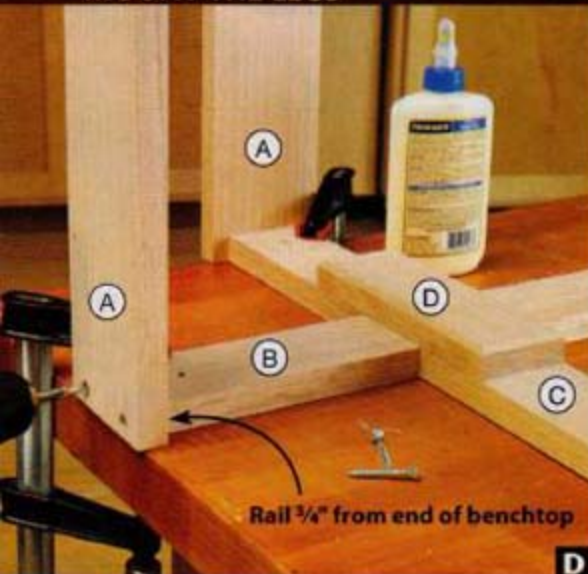

Rail  $\frac{3}{4}$ " from end of benchtop

Glue the legs (A), centered, to the ends of the long rail (B) and short rails (C). Drill  $\frac{7}{64}$ " pilot holes into the rails, and drive the screws.

## ATTACH LOWER RAILS/CLEAT

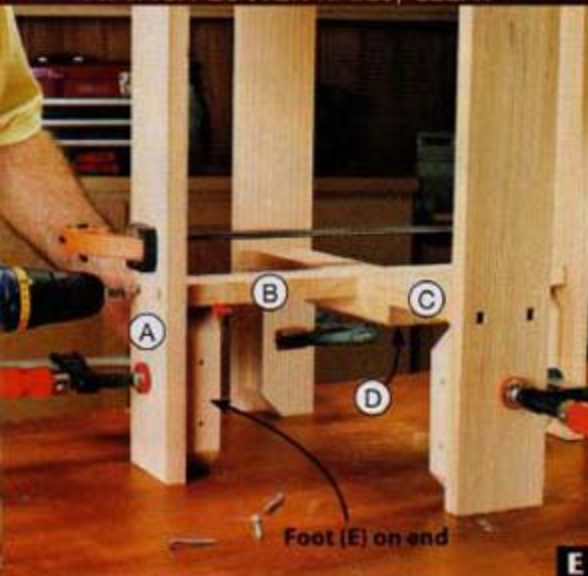

With the remaining rail/cleat assembly (B/C/D) in position, drill pilot holes, centered in the mortises, into the rails. Drive the screws.

## ATTACH THE FEET

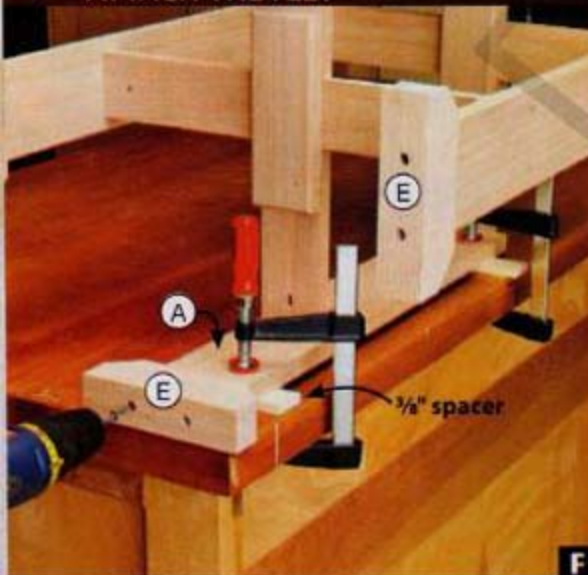

Glue and center a foot (E) on the bottom of a leg (A). Using the foot shank holes as guides, drill pilot holes into the leg. Drive the screws.

## SHOP TIP

### How to safely make mortise plugs using your tablesaw

Here's a simple and safe way to form small plugs for the square mortises. This method keeps your fingers out of harm's way and prevents having to push a small workpiece between the blade and fence.

To make a  $\frac{3}{8}$ "-square blank 8" long for the mortise plugs (G), for example, cut a piece of  $\frac{3}{4}$ " stock to  $2\frac{1}{2} \times 16$ ". Position the fence  $\frac{3}{8}$ " from the *inside* of the blade. Place a piece of masking tape about 5" long on the saw table 4" in front of the blade and perpendicular to the fence for a visual stop, as shown *top right*. Raise the blade to  $\frac{7}{16}$ ". With the stock on edge and tightly against the fence, rip the piece, stopping when the back end reaches the tape. Raise the blade  $\frac{1}{16}$ " ( $\frac{1}{2}$ " total height). Flip the stock onto its face, and rip it again to form a  $\frac{3}{8}$ "-square blank. Now, crosscut the piece to free the blank.

To safely and accurately crosscut the  $\frac{7}{16}$ "-long plugs from the blank, attach an L-shaped extension/sled made from  $\frac{3}{4}$ " scrap to your miter gauge, as shown *bottom right*. Raise the blade to about  $1\frac{1}{2}$ ", and make a cut through the extension/sled. Draw a line on the sled  $\frac{7}{16}$ " from the kerf. Align the end of the blank with the mark to crosscut the plugs.

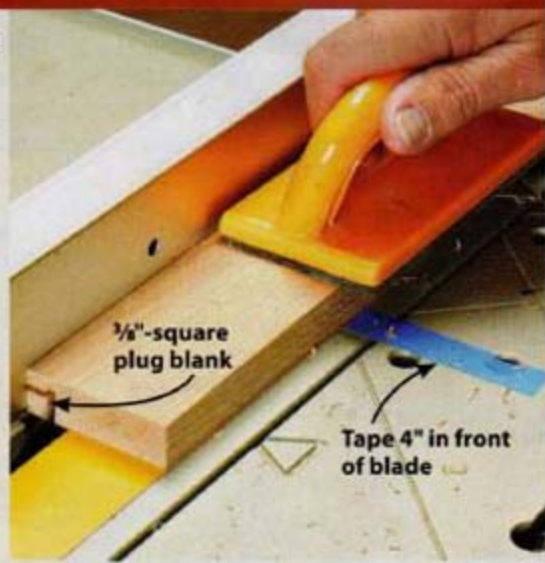

$\frac{3}{8}$ "-square plug blank

Tape 4" in front of blade

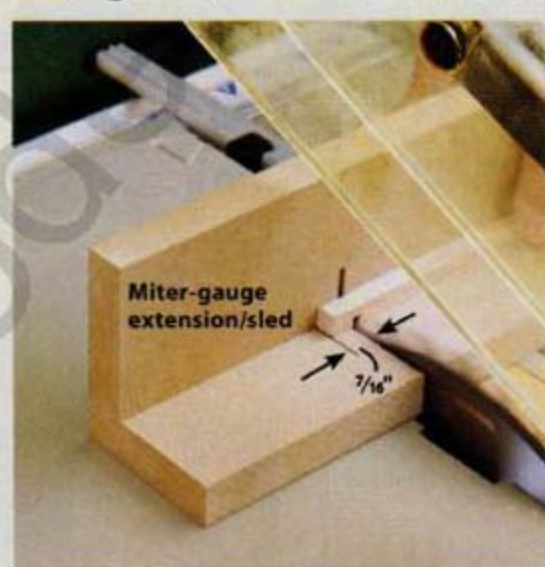

Miter-gauge extension/sled

$\frac{7}{16}$ "

the next cut. To keep your hands safely clear of the blade, clamp each foot to the extension as you make the cut.

**7** Mark centerpoints on the bottom of the feet (E) for the mounting holes, where dimensioned. Drill  $\frac{5}{32}$ " shank holes through each foot at the centerpoints. Then, centering a  $\frac{3}{8}$ " twist drill on each shank hole, drill a  $\frac{1}{4}$ "-deep counterbore into the bottom.

**8** Sand all of the parts you've made so far to 220 grit.

### Now assemble the base

**1** With the cleat (D) facing *up*, clamp a rail/cleat assembly (B/C/D) to a corner of your workbench, positioning an end of the long rail (B) and a short rail (C)  $\frac{3}{4}$ " from the edge and end of the benchtop. Mount the top end of a leg (A) to the end of each rail near the edge and end of the benchtop [Photo D]. Unclamp the assembly, rotate it 180°, and reclamp. Then attach the remaining legs.

**2** To mount the remaining rail/cleat assembly (B/C/D) with the *bottom* face of the rails (C/D)  $6\frac{1}{4}$ " from the bot-

toms of the legs (A) [Drawing 1], position the table with the bottom of the legs down. Then, clamp a  $6\frac{1}{4}$ "-long foot (E) on end as a spacer to the *inside* face of each leg, flush at the bottom. Apply a small amount of glue to the mating areas for the rail ends on the *inside* faces of the legs. (Applying the glue to the legs instead of the rail ends prevents smearing.) Now, with the cleat (D) facing *down*, angle the rail/cleat assembly into position on the feet. Screw the legs to the rails [Photo E]. Unclamp and remove the feet.

**3** To mount the feet (E), lay the table on a side with  $\frac{3}{8}$ " spacers under a leg (A) and clamp it in place. The spacers will center the  $1\frac{1}{2}$ " foot thickness on the  $\frac{3}{4}$ "-thick leg. Apply glue to the leg bottom. Then, center a foot end to end on the leg and mount it [Photo F]. Repeat to attach the remaining feet.

### Plug the leg holes

**1** To plug the counterbored top pair of holes in each leg (A), cut eight  $\frac{3}{4}$ "-long pieces from a  $\frac{3}{8}$ "-diameter oak

## SHOP TIP

### Make panel glue-ups a snap with this trick

You don't need an arsenal of clamps to form flat edge-glued panels. You can do it using just two clamps (inexpensive pipe clamps work great) and an easy-to-make jig. Here's how.

To edge-glide the 27½"- and 16½"-wide panels for the top (H) and shelf (I), for example, make the clamping jig and four wedges, shown *below*, from a 2x4. (We jigsawed the wedges to shape.) Lay out and jigsaw the opening in the bottom of the jig to shape. (The 30" opening at the bottom and 19" opening between the cleats at the top are sized to fit the top and shelf panels plus the wedges.) Now, glue and clamp a panel together with the top faces flush, center the appropriate opening in the jig across the panel, and drive a pair of wedges between the jig and panel at each end, as shown *top right*.

To accommodate different size panels, size the jig openings 2½" wider than the panels. Adding the cleats to the top lets you use the jig for more than one panel size.

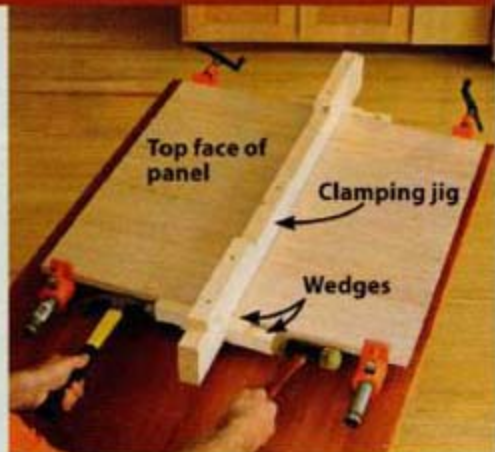
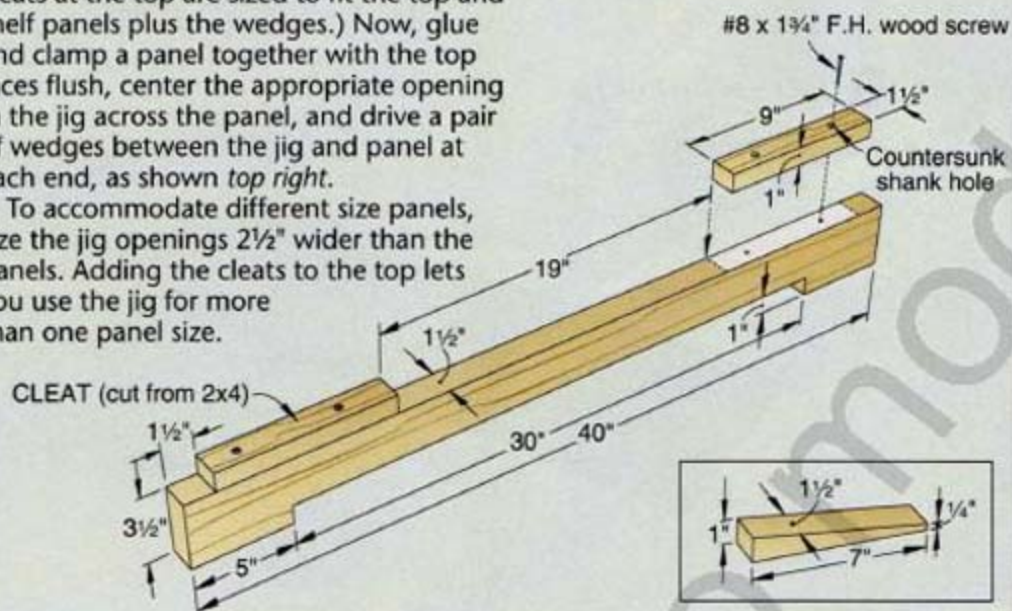

## LAY OUT THE TOP AND SHELF

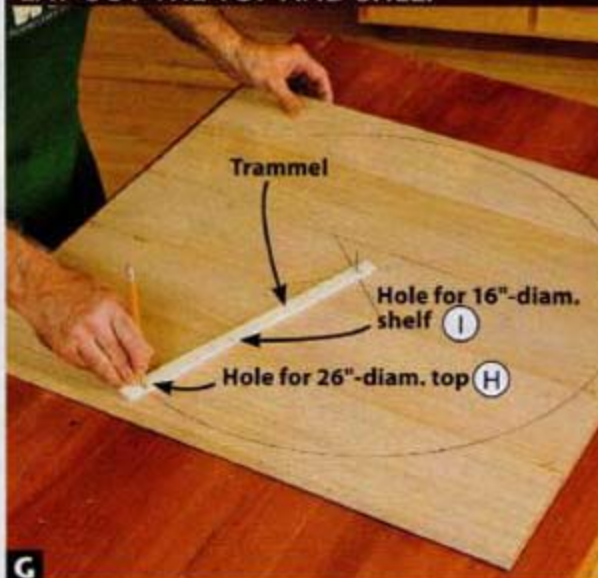

**G** Insert a sharp pencil through the appropriate hole in the trammel to draw a circle on the top (H) and shelf (I) blanks.

## JIGSAW THE TOP AND SHELF

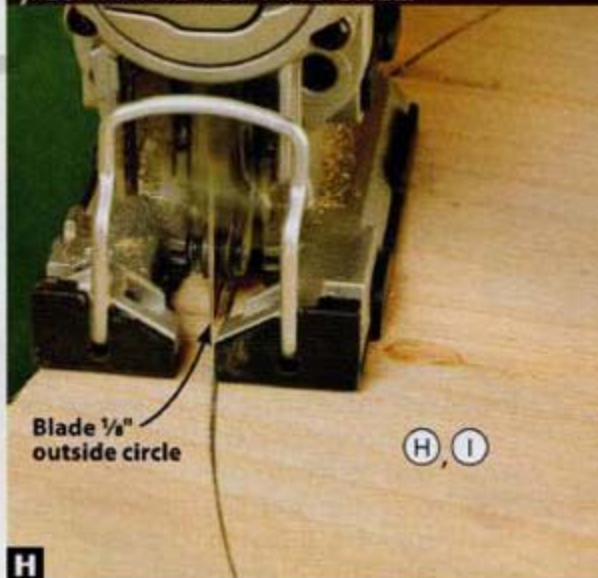

**H** Jigsaw the top (H) and shelf (I) blanks ⅛" outside the line. To prevent splintering, use a high-quality blade with 10 teeth per inch.

## ROUT THE TOP AND SHELF

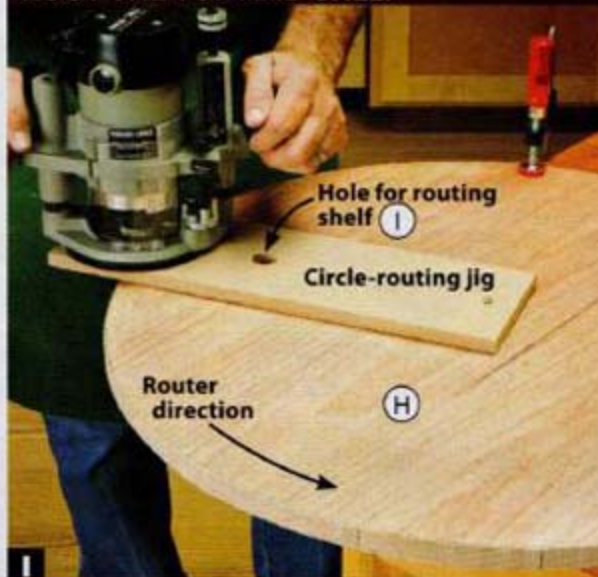

**I** Using the circle-routing jig, plunge the router while moving counterclockwise (to avoid burning the wood) and rout the top (H).

dowel for the round plugs (F). As an alternative, if you have a ⅜" plug cutter (a tapered type works best) and a drill press, you can make the plugs from ¾" stock that matches the leg grain pattern and color. Glue the dowels (or plugs) into the holes. Let the glue dry overnight. Trim the plugs with a flush-trim saw, and sand smooth. To prevent marring the legs with the saw, place an index card with a hole in it over each plug.

**2** To form the mortise plugs (G), prepare a ⅝×⅝" blank 8" long using your tablesaw. Crosscut eight ⅞"-long plugs from the blank. To ensure safety when you make the blank and crosscut the plugs, see the *Shop Tip, opposite page*.

**3** Apply a small amount of glue in each mortise, and press a plug into it. (The plugs project ⅛".) Lightly sand the ends of the plugs.

### Add the top and shelf

**1** Edge-glide five 1x6s (¾×5½" actual) to form a 27½"-square blank for the top (H) and three 1x6s to make a 16½"-square blank for the shelf (I). Shy on

clamps? No problem. See the *Shop Tip, above*, for a way to glue up the panels using just two clamps and a simple jig.

**2** When the glue dries, scrape off the squeeze-out. Then, sand the blanks smooth to 220 grit using your random-orbit sander, leveling any uneven joints.

**3** To lay out the top (H) and shelf (I) on the blanks [Drawing 2], draw diagonals on the *bottom* faces to find the centers. Next, drill a ⅜" hole ½" deep at each center for a pivot to draw and rout the circles. To make a trammel for drawing the circles, cut a ¾×15" piece from ⅛"- or ¼"-thick scrap. Measuring from one end, mark centerpoints at the middle of the piece at 1" (for the pivot point), 9" (for the shelf 8" radius), and 14" (for the top 13" radius). Drill a ⅜" hole at each centerpoint. Using a 6d finishing nail as a pivot for the trammel, draw a circle with a 26" diameter (13" radius) on the top blank and one with 16" diameter (8" radius) on the shelf blank [Photo G].

**4** Jigsaw the blanks to just outside the marked circles [Photo H]. To prevent cutting into your worktop, unclamp and

## 2 TOP AND SHELF LAYOUT

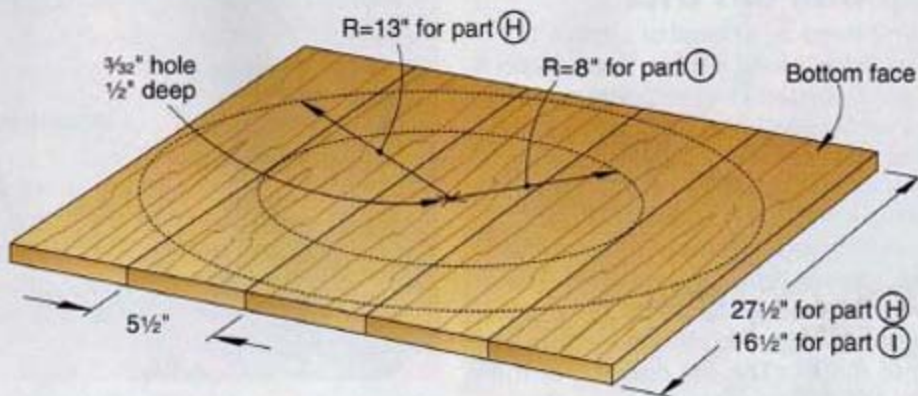

## 3 CIRCLE-ROUTING JIG

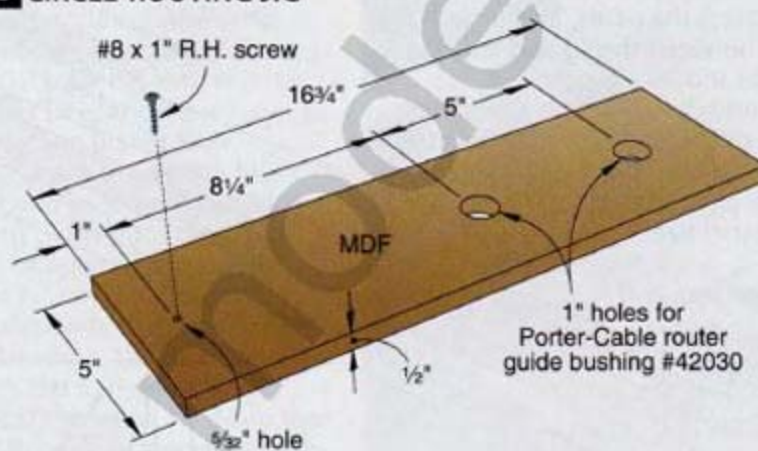

reposition the blanks as needed to keep an uncut portion overhanging the top.

**5** To rout the top (H) and shelf (I) to the finished sizes, make the circle-routing jig [Drawing 3] from a 5x16<sup>3</sup>/<sub>4</sub>" piece of 1/2" MDF. Note that the 1" holes shown are sized for a Porter-Cable guide bushing #42030. Bore the holes in your jig to fit your bushing.

Next, chuck a 1/2" straight bit in your plunge router, centered in the bushing. Attach the jig to the center hole in the top using a #8x1" roundhead screw. Now, insert the guide bushing into the outer hole in the jig, and rout the top [Photo 1]. Unclamp and reposition the top as needed to provide clearance between the bit and your worktop. Repeat to rout the shelf, locating the bushing in the inner hole.

**6** Take the router off the jig. Remove the guide bushing and switch to your chamfer bit. Then, rout a 1/8" chamfer around both edges of the top (H) [Drawing 1]. Sand the chamfers.

## Finish up

**1** Finish-sand to 220 grit, and remove the dust. Apply stain and clear finish. (We applied Old Masters Early American no. 11716 wiping stain, followed by three coats of a water-based, clear satin, polyurethane finish, sanding to 220 grit between coats.)

**2** Center the top (H) on the table. Using the holes in the long and short rails (B, C) as guides, drill pilot holes into the top. Drive the screws [Drawing 1]. Repeat to mount the shelf

(I). Now place your masterpiece next to a chair or sofa, and step back to admire your splendid work. 🌳

Written by **Owen Duvall** with **Chuck Hedlund**  
Project design: **Jeff Mertz**  
Illustrations: **Roxanne LeMoine; Lorna Johnson**

## Cutting Diagram

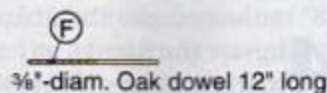
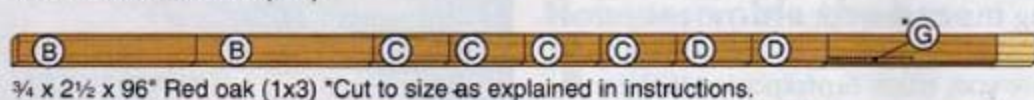
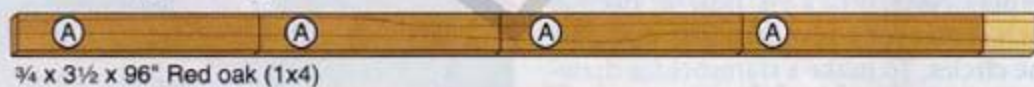

## Materials List

Part	FINISHED SIZE			Matl.	Qty.
	T	W	L		
A legs	3/4"	3 1/2"	22 3/4"	O	4
B long rails	3/4"	2 1/2"	16 3/4"	O	2
C short rails	3/4"	2 1/2"	7 1/8"	O	4
D cleats	3/4"	2 1/2"	7 1/8"	O	2
E feet	1 1/2"	2 1/4"	6 1/4"	LO	4
F* round plugs	3/8" diam.	3/8"	OD		8
G* mortise plugs	3/8"	3/8"	7/16"	O	8
H* top	3/4"	26"	diam.	EO	1
I* shelf	3/4"	16"	diam.	EO	1

\*Parts initially cut oversize. See the instructions.

**Materials key:** O—red oak, LO—laminated red oak, OD—oak dowel, EO—edge-glued oak.

**Supplies:** #8x1 1/2" flathead wood screws (16), #8x1 3/4" flathead wood screws (4), #8x3" flathead wood screws (8), #8x1" roundhead screw, #8x1 1/4" roundhead screws (8), #8 flat washers (8), 6d finishing nail.

**Blade and bits:** High-quality jigsaw blade with 10 teeth per inch, 3/8" brad-point bit, 45° chamfer and 1/2" straight router bits, 3/8" tapered plug cutter (optional).



# REVOLUTIONARY!



## Introducing the new innovative CT50™ Professional Cordless Staple Gun

Introducing Arrow's new innovative quality tool, the CT50™. More than just a sleek, light weight design, this cordless wonder is a rugged, heavy duty staple gun that appeals to everyone, from the do-it-yourselfer to the contractor.

The light weight 10.8v Lithium-ion battery guarantees more power, while firing up to 1500 staples on a single charge. Its unique "on-board"

battery design maintains perfect balance for increased control and accuracy.

The ultra-bright "LED guide light" will light any surface with precision positioning of the staple location. The adjustable "depth of drive" control lets you perfectly fire each staple to the desired depth.

Unique to the CT50™ this tool holds two full strips of any of the six Arrow T50® staple sizes

saving time on the project.

All this, and more, in a well thought out, ergonomically designed, professional tool that will make any project faster and easier for both the pro and do-it-yourselfer. The additional endless list of features will ensure a professional finish to every project.



PROFESSIONAL FASTENING  
— SINCE 1929 —

#### Arrow Fastener Co., Inc.

271 Mayhill Street, Saddle Brook, NJ 07663  
Phone: 1-201-843-6900 Fax: 1-201-843-3911

#### Canada: Jardel Distributors, Inc.

6505 Metropolitan Blvd. East, Montreal, Quebec H1P 1X9  
Phone: 1-514-321-3983 Fax: 1-514-321-9424

#### Arrow Fastener U.K. Ltd.

Unit 5 ZK Park, 23 Commerce Way, Croydon CR0 4ZS, Surrey

[www.arrowfastener.com](http://www.arrowfastener.com)

© 2007 Arrow Fastener Company, Inc.

# Crafting Keepsake Furniture

As competitive compromises whittle away at the durability of today's mass-produced furniture, building your own heirloom-quality pieces makes more sense than ever.

**W**alk through a furniture store, and you might begin to wonder if it still makes sense to build your own furniture. You'd be hard-pressed to buy just the wood for the low price of an attractive item on the showroom floor. Then you'll invest days, weeks, or months in your shop doing the work. What's the point?

Call it heresy, but even we ask ourselves that question from time to time. So we thought it would be enlightening to investigate this buy-vs.-build issue and ask our online audience at [woodmagazine.com](http://woodmagazine.com) for their opinions,

which we sprinkled throughout this article. Their responses and our inquiry confirmed, more than ever, that if you have wood-working skills or the drive to learn them, there's no better time to build your own furniture than right now.

Store-Bought (\$100)...

*"Some 'serial decorators' want to redecorate every five to seven years, about the same frequency that they change houses. This is good, because some of the furniture they're buying will only last that long."*

—Keith Mealy, Cincinnati

...vs. Shop-Built (\$180\*)

*"My children ask me to make their furniture. They know that what I make will become family hand-downs for their children, and they truly appreciate what it takes to make heirloom-quality furniture."*

—James Hutchinson, O'Fallon, Mo.

\* Price for materials alone. This project could be built in about 20 hours.

# in a *Throwaway World*

## A tale of two tables

The store ad promised “stylish furniture at low prices”—magic words for a young couple in their first apartment. Sure enough, an end table on the showroom floor caught their eye with its trendy look, budget-friendly price, and instant availability. They had one squeezed into their car trunk and arranged in their family room less than an hour later.

Another couple, another table. This one, however, never saw the inside of a cargo ship. It began as a stack of rough-cut lumber and a woodworker’s goal of giving his son and new daughter-in-law an heirloom they’d pass along to his future grandchildren. Days turned into weeks as the lumber became a solidly built table with timeless style.

As years passed, the store-bought table began to show its quality compromises. Stapled parts pulled loose, melamine-covered surfaces chipped around the edges, and a parade of newer styles in magazines and furniture-store ads made the once-fresh style look dated. Within a decade, the table moved from family room to basement to thrift store and finally, one trash day, to the curb. The shop-made table grew a patina from daily use, but its materials and joinery endured as its creator intended. After 30 years, this table joined a family legacy; the other joined a landfill.

## Imports pressure prices

Moderately priced furniture drives most of an \$86.5 billion business. Among makers of wood furniture (not including upholstered pieces), U.S. factories accounted for \$13.5 billion in sales during 2006—narrowly ahead of the \$10.9 billion in imported wood furniture, about half of it from China.

*“Both my wife and I are very turned off by the current throwaway society and by the notion of redoing a room or whole house just to have ‘new’ things.”*

—Carl Love, Annapolis, Md.

That’s just an industry snapshot. The moving picture reveals bigger changes for American furnituremakers: Domestic wood furniture companies grew their business 39 percent during the decade ending in 2006. Not bad, but China’s production increased 1,219 percent.

American consumers have been both the beneficiaries and the victims of this oversupply. Beneficiaries because wood furniture prices dropped 20 percent from 10 years ago, despite higher raw material costs. However, downward price pressure can also victimize consumers when manufacturers compromise quality to stay competitive.

You can read about these quality compromises on Web sites such as [consumeraffairs.com](http://consumeraffairs.com), where a Texas woman writes, “My daughter sat in one of the chairs and it broke. She nearly fell with her baby in her arms.”

“Korry” from Cary, N.C., writes, “One table had splits and another was broken. I called customer service, and they told me it was their policy to first send a technician out to try to fix it. What?!! Fix it? Glue it together? Come on people!”

*“Disposable furniture is for nomads.”* —Matt Seiler, Tinley Park, Ill.

## MATERIALS: STORE-BOUGHT VS. SHOP-MADE



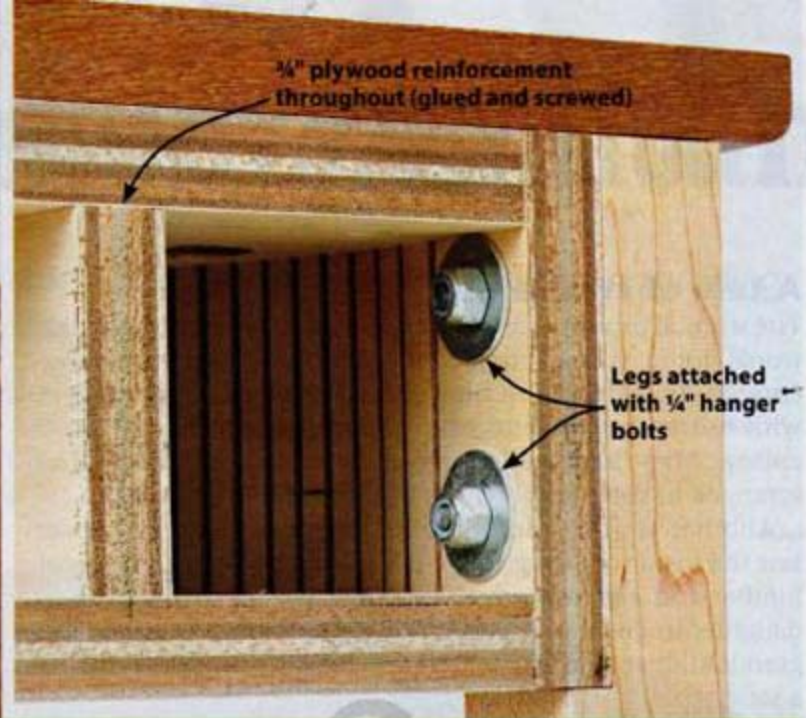
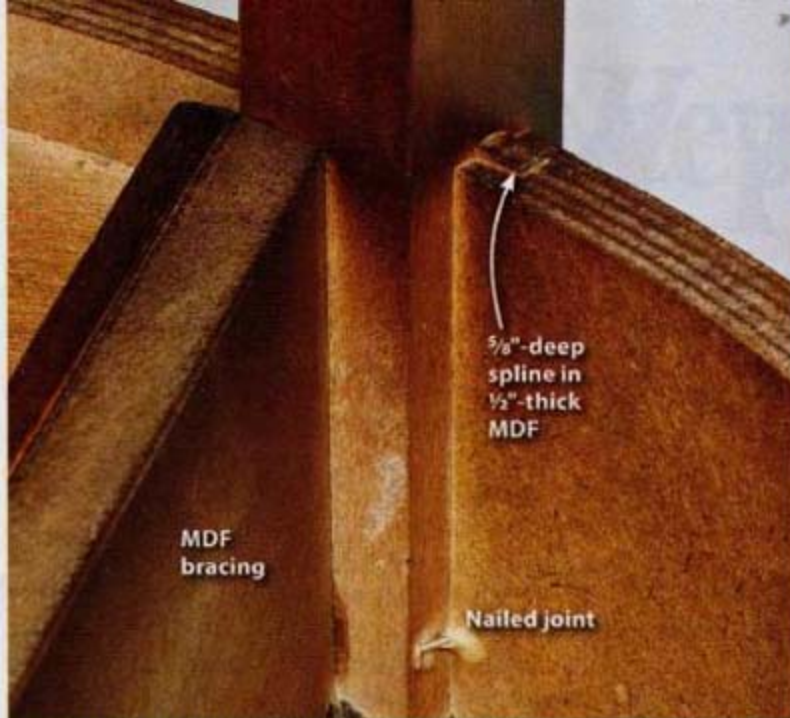

**CRAFTSMANSHIP: STORE-BOUGHT VS. SHOP-MADE**

It's not that "imported" necessarily equates with "low-quality," nor should it. Higher quality requires management at the factory, so better companies maintain their own personnel overseas. Some go a step further.

"A good number of large retail stores attempted to go direct and import finished products," says Jackie Hirschhaut, public relations vice president for the American Home Furnishings Alliance. "Managing that business is so outside their realm of expertise, they're returning to dealing with manufacturers."

While retailers and manufacturers try to hold the quality line despite oversupply and a sluggish economy, there's a healthy niche for traditionally built, solid-hardwood furniture. "Solid-hardwood furniture is thriving at the upper end. There's a segment for whom solid wood furniture is an aspiration," Hirschhaut says. If you don't enjoy a high income, though, that means a hardwood dining table may not leave you with enough money to put food on it.

### That's why it's "free time"

If most of us woodworking hobbyists turned pro, we probably couldn't charge enough to make a profit. For example, look at the cost to make the *WOOD* magazine Arts & Crafts bedroom collection below: a bed with a headboard and footboard, two nightstands, a six-drawer dresser, and a chest.

Lumber and plywood costs, allowing 15 percent for waste, total about \$1,350. Then add \$250 more for hardware, finish, and shop supplies. You're on your own for using this as an excuse to buy new tools.

We estimate it would take 21 to 26 days to build all five pieces working 8-hour days. At \$50 per hour, the estimated labor costs would be \$8,400 to \$10,400. The grand total for this handmade, solid-oak collection could exceed \$12,000.

Now compare that to a bedroom set from your local furniture store or similar solid-oak pieces from [missionliving.com](http://missionliving.com), which sell for about \$4,450. Even a handmade bedroom set from Case Brothers ([casebros.com](http://casebros.com)) costs only about \$7,900.

You could give yourself a 50 percent "pay" cut, or about \$5,000 in labor. That's on par with the store-bought pieces, but still a big investment for most folks. So, you old softy, you build the set for free and lose money on the lumber.

In the end, a gift of shop-made furniture becomes more than something for sitting, eating, or sleeping: It's a gift of your skills, time, and love. The question is, will a gift meant to last beyond a lifetime be welcome that long?

*"Until consumers reevaluate their purchasing decisions, only those who build, repair/restore, or who can afford custom will have pieces that won't go into the trash every 5-10 years."*

—Paul Hauschildt, Minneapolis

### The permanence trend

Businesses pay megabucks to surreptitiously plant products in TV shows and movie scenes because it works. Monkey-see-monkey-shop has become institutionalized on Web sites, such as [SeenOn.com](http://SeenOn.com) or [About.com](http://About.com). That oval wood-and-glass coffee table you saw on *Desperate Housewives*? It's there.

The ability to buy the latest thing at mouse-click speed has accelerated trends to a velocity nearly too fast for consumers to track. But this trend-trudge toward instant gratification shows signs of becoming ungratifying and even unfashionably wasteful. Tim Copeland hears environmental concerns from buyers of Copeland Furniture's traditionally made hardwood pieces. "Shipping goods halfway around the world costs





Easily damaged toner leaves bare wood.

Painted round edges show scuff marks.

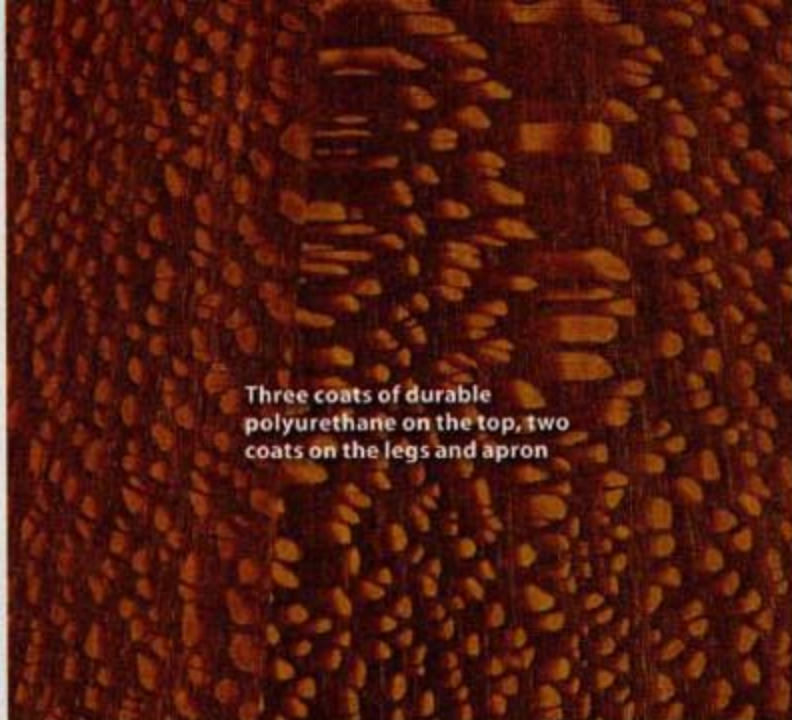

Three coats of durable polyurethane on the top, two coats on the legs and apron

## FINISH: STORE-BOUGHT VS. SHOP-MADE

a great deal in fossil fuels," Copeland says. Manufacturing's impact on the environment also concerns them. "Is it being done where there are reasonable regulations?"

Ad agency JWT studies enough human behavior to know a trend when it spots one. Its newsletter ranked "rethinking instant gratification" as a trend likely to last beyond this year: "'Custom-made' and 'one-of-a-kind' are rising above the mass-produced din of 'now.'" Translation: The easier it is to buy something, the less desirability it offers, whether that's a dining table or the plates upon it. That may explain why furniture stores fight for business with get-it-now ads while custom furniture makers enjoy years-long backlogs for one-of-a-kind pieces to satisfy clients who can afford to wait for eventual gratification over the instant kind.

After decades of being told that everything from dolls to dollar coins will become "collectible," now perhaps people can appreciate, value, and preserve handmade furniture for its beauty, quality, and rarity. Maybe the recipients of woodworkers' gifts, and the generations to follow, truly will appreciate the uniqueness of what they possess.

***"If you tried to buy what I make, you couldn't pay for all the work I have in it. What I make is not for sale; it is my gift to the people I care about the most."***

—Ron Altier, West Lafayette, Ohio

### And so we build

Ah, those hulking, dark-stained pine waterbeds from the 1970s: Where are they now? When you craft heirloom furniture, you expect the quality to last for generations. But solid wood and skillful joinery alone aren't enough to give a piece heirloom status. You also need to choose a furniture style as enduring as the construction.

Fortunately, woodworkers can choose from enough time-tested furniture styles to satisfy all but the most trendy tastes. There's Queen Anne for lovers of classic

***"After I'm gone, I hope my kids fight for my stuff like wolves over a dead moose."***

—Ted Victor, Lansing, Mich.

elegance, Arts & Crafts for those who prize clean lines and sturdy proportions, and Shaker for ones who value simplicity with a lighter touch. All have admirers today, just as they were admired decades or centuries ago. So, worries about building the "right" style shouldn't give you a project procrastination excuse. People you care about are waiting, so get busy.

For the friends and descendants of many woodworkers, these gifts of lumber, labor, and love in the form of finely made tables, chairs, or bedroom sets may be the closest they will come to owning the sort of custom-made hardwood furnishings commissioned by the well-to-do. Today they may be gifts given in exchange for a simple "thank you." Generations later, though, these handmade legacies will be as treasured as the memories of their makers. 🌲

Written by **Bob Wilson** and **Megan Stotmeister**

***"When my wife and I are both gone from this world, I fully intend for our furniture to go to our descendants. That is the driving force behind my woodworking. I don't want people to walk by some rock with my birthdate on it and wonder what kind of man I was. I want my great-great-great-great-grandchildren to sit at a table or a desk I built and know what kind of man I was. That's immortality."***

—Chuck Norgaard, Lake Crystal, Minn.

# Keys to Successful Hand-Sanding

A straightforward strategy for faster, smoother results

**W**e're all for power-sanding, but once the heavy work is done, corded tools can't compete with a little elbow grease. That's because power sanders leave small but detectable scratch patterns that can telegraph through your finish.

In contrast, a final hand-sanding (even when using the same grit as the power sander) produces a finer, grain-aligned scratch pattern that disappears under the first coat of stain, oil, or film-forming finish. Plus, hand-sanding offers more flexibility and control you won't find from the corded competition. For smoothing curves, corners, and other small or delicate under-sanded spots, it's hard to beat a custom-made sanding block.

In this article, we'll tell you everything you need to create an economical hand-sanding starter kit. This selection of abrasives, blocks, and other materials—and the proper technique—helps you tackle most raw wood, mid-finish, and final polishing chores. You'll also learn how to make simple specialty blocks to smooth over complex profiles and custom curves.

## Selecting sandpaper: Stock up to sand less

Good news! Your first goal is to sand as little as possible. Usually, this means stopping at 180 grit before applying a film-forming finish, such as lacquer or poly, and at 220 grit before oil. (Some woodworkers prefer working up to 320

grit. Test a sample piece of wood to see and feel if the extra sanding is worth it.) Getting a super-smooth finish also means lightly sanding each coat with 320- or 400-grit paper and then polishing the final coat.

If you're using a random-orbit sander, you don't need to buy a lot of extra sandpaper. For sanding raw wood, buy a few rolls of aluminum-oxide sandpaper (120, 150, and 220 grit) to complement your existing collection of sanding discs. Trash that box of partially used sandpaper scraps. You may think you're saving money, but overused scraps cut more slowly, and can leave an uneven scratch pattern or burnish the surface. In either case, you wind up with an uneven looking finish. With the rolls, you tear off only as much as you need and toss it when you're done. (For larger surfaces, buy a hand-sanding pad, *below*, equipped

### GRIT 'ER DONE: A SIMPLE HAND-SANDING KIT COVERS EVERY STEP

	TYPE	GRITS TO KEEP ON HAND	NOTES
<b>STEP 1:</b> Raw wood	Aluminum oxide	150, 180, 220	For faster sanding, replace worn paper frequently.
<b>STEP 2:</b> Between finish coats	Stearated aluminum oxide	320, 400	For dry-sanding only; don't use on water-based finishes.
	Silicon carbide wet/dry	320, 400	Best for water-based finishes; tends to clog when dry-sanding.
<b>STEP 3:</b> Final polish	Nonwoven synthetic pad	Ultrafine (gray)	Before sanding, make sure finish is fully cured.
	Nonwoven synthetic pad	Nonabrasive	Great for applying paste wax.

### COME ON OVER TO MY PAD



This flexible sanding pad uses hook-and-loop sanding discs from your power sander, yet conforms easily to curved faces. The elastic strap reduces hand fatigue.

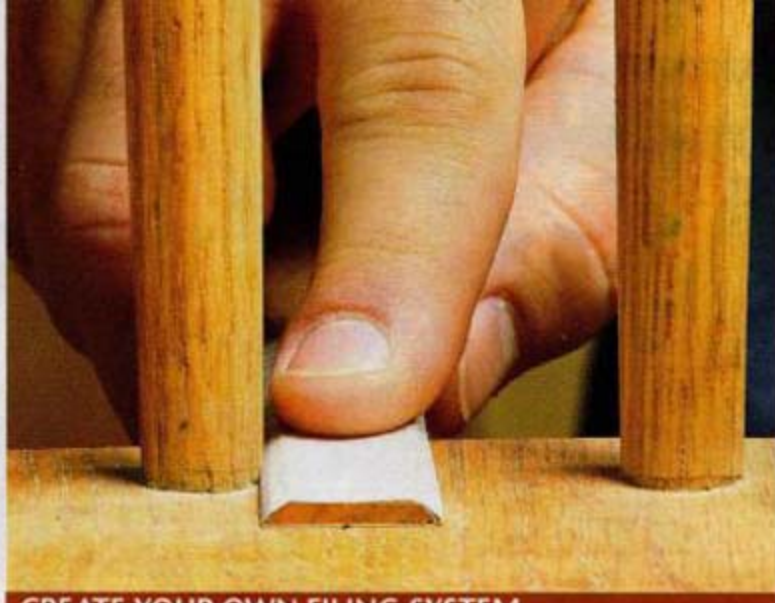
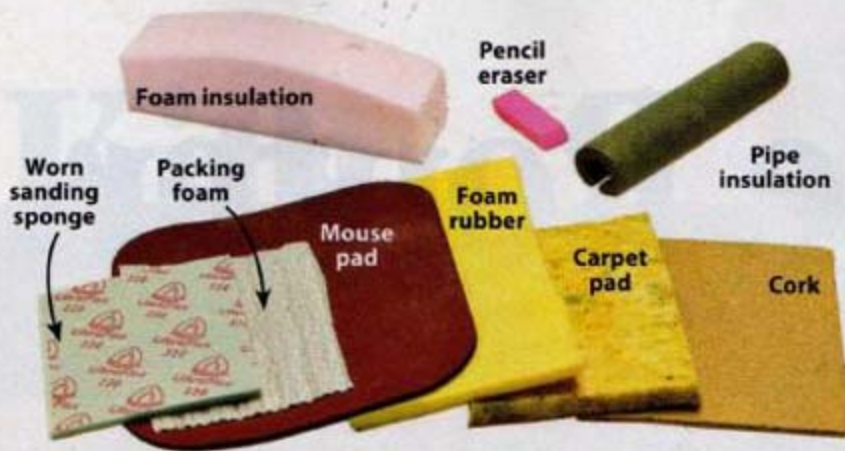

### YOU'LL FIND SOFT STUFF EVERYWHERE

Why spend when you can scrounge? We rounded up these sandpaper backers in just a few minutes rummaging around the house and shop.

with hook-and-loop discs from your random-orbit sander.)

Because power sanders cut through a finish in no time flat, it's best to sand finishes by hand. And here, you have two choices: dry- or wet-sanding. Dry-sanding offers more control than wet-, plus it's easier to see what you're doing. However, the finish can clog the paper, especially if the finish isn't fully cured. To prevent this, use a zinc-stearated abrasive. The stearate coating resists clogs by lubricating the paper, but the soaplike residue that remains after sanding may cause bonding problems with some water-based finishes. To be safe, dry-sand those finishes with silicon-carbide paper, or switch to wet-sanding.

In wet-sanding, use a liquid, such as mineral oil, mineral spirits, or soapy water, to provide lubrication and float off debris that otherwise would clog the sandpaper. For this, you want silicon-carbide wet/dry sandpaper that can stand up to wet work. The disadvantage of wet-sanding, besides the mess, is that the liquid creates the illusion of a thicker

finish. To avoid accidentally cutting through your finish, periodically wipe off the residue to check your progress.

Finally, invest in a few nonwoven synthetic pads for final polishing. The ultrafine (gray) pads contain just enough abrasive to remove minor imperfections without cutting through the finish. Use the nonabrasive (white) pads with a little wax; then buff with a rag to work up a showroom glow.

### Save big by making your own sanding block set

Good backup is as important as the right sandpaper. By keeping the sandpaper in constant, even contact with the wood, a sanding block helps you finish faster and prevents unintentionally dishing or rounding-over your work. Luckily, you don't need to spend big bucks for good backup. Before you buy anything, search your shop for scraps, such as ceiling tile, sheet foam, and cork (see *top left* photo), that might provide firm support with just enough flex to prevent premature paper wear-out.

### CREATE YOUR OWN FILING SYSTEM

Glue heavyweight sandpaper to hardwood strips to make "files" for getting into narrow spots and tight corners. Mark the grit on the stick.

Leave those chunks of hardwood in the scrap bin. Because they don't allow the paper to flex, hardwood blocks tend to wear out paper in record time and leave wood looking more scratched than smooth. But by gluing sandpaper to hardwood strips, as shown *above*, you can make wooden files that excel at shaping corners and smoothing tight spots. Or, wrap a scrap of mating joint stock with self-adhesive paper that perfectly matches the profile, as shown at *bottom left*. For wet-sanding, choose blocks that don't warp, swell, or disintegrate when wet, such as sponges, rubber erasers, or even old mouse pads.

Size matters, too. In this case, smaller is better. You shouldn't need to resort to a big hand-sanding block, especially if you've already used a power sander. Smaller blocks—no bigger than a quarter sheet of standard paper—offer more control and a better feel for what you're sanding. Make the blocks about an inch narrower than your sandpaper so you can wrap and comfortably grip the paper along the sides.

When it's time to sand complex profiles, small sanding blocks really shine. In most cases, it's faster and easier to smooth a tricky curve in parts, simply by using a few smaller blocks, as shown *opposite top*, than it is to make a custom-shaped block. For broad curves, try using rigid foam insulation. Shape the foam to fit the curve, and then attach sandpaper, as shown at *near left*.

### Sources

5" Flex Hand Pad/H&L #FR21150, \$5.95; Raw Wood Sanding Kit #RWS-001, \$24.95; Finer-Grit Wood & Finish-Sanding Kit #FSK-001, \$19.95 from Klingspor's Woodworking Shop. Call or click: 800-228-0000 or woodworkingshop.com.

Written by Joe Hurst-Wajszczuk

### MAXIMIZE MATING SCRAPS



To sand the rule joint on this drop-leaf tabletop, we used a scrap cutoff from the mating leaf to create a perfect-match sanding block.

### INSULATION TACKLES CURVES



Foam insulation provides firm backup, and is easy to cut or sand to shape. An inexpensive offcut provides enough sanding-block stock for years.

# Multibase Router

We tested 12 combo packs in search of the best—and it didn't take long to knock a few out of the running.

**W**hether you're buying your first router or adding to those already on the shelf, you can't beat the value and versatility of a multibase kit. Of course, you could buy separate fixed-base or plunge units for about \$90 to \$180 each. But with many of today's combo kits, you can get both bases and one motor for just another \$40 or so, much cheaper than buying two separate routers.

But which kit should you buy? To find out, we tested 11 two-base kits and one with three bases. We ran them through a battery of tasks we expect routers in this class to handle. And we found good value and performance in several kits.

## There's plenty of power for most routing tasks

First off, we wanted to find out if these routers have the necessary power. All of them have soft-start motors, a feature that requires a couple of seconds for the motor to reach full speed. This eliminates the jerk produced by motor torque at start-up. Each router displayed ample power for handheld work such as routing edge profiles and plowing dadoes, grooves, and deep mortises.

To get a head-to-head comparison of power, we mounted each router in its fixed base in a router table. We set each unit at 14,000 rpm, and fed hard maple at a reasonable 10-feet-per-minute

(fpm) rate using a Grizzly power feeder while cutting a  $\frac{3}{8}$ " bead-and-cove profile. (See photo below.) Most handled this task with guns a-blazin' as their electronic speed controls maintained bit speed throughout the cut.

However, four units took a hit in this test. The Porter-Cable 694VK and Skil 1825 struggled without electronic speed controls. (Feedback circuitry on routers with this feature monitors spindle speed and sends more juice to the motor during heavy cuts to maintain speed.) The 694VK could muster only about half its speed, even when we slowed the feed rate to 6 fpm. We brought the Skil to a stop with the initial settings. We had to increase its speed to 18,000 rpm and slow the feed rate to 6 fpm before it could make the cut.

## WHO'S GOT THE POWER?



We measured spindle speed with a phototachometer as each router machined a profile in  $\frac{3}{4}$ "-thick hard maple.



# Kits



The electronic controls on Craftsman's 28084 and the Freud FT1702VCEK struggled to maintain full speed, varying by 3,000 to 4,000 rpm throughout the cut. Still, we saw no negative impact on cut quality.

**THE VERDICT:** The Porter-Cable 694VK and Skil 1825 are eliminated from consideration. We place the Craftsman 28084 and Freud on "probation."

## If power is no problem, go for comfort and feel

At 8 to 12 lbs, this size router proves a joy to use, lighter and more nimble than bulky 3-hp routers. The Milwaukee 5616-24 felt best in our hands with the easiest-to-grip rubber handles (on both bases) and its rubber-molded palm grip around the fixed base, as shown *below*.



On edge treatments we felt confident and comfortable gripping Milwaukee's fixed-base router with only one hand.

This model exhibited no vibration, and its on/off switch was easy to reach on both bases without letting go of the handles.

Bosch's 1617EVSPK felt almost as good as the Milwaukee. The wooden handles on the fixed base were a little slick but comfortable, and the plunge base was a dream to operate with easy-to-grip rubber handles, exceptional balance, and controls easily within reach.

The Porter-Cable 895PK (*below*) has dual on/off switches, one at the top of the motor—handy in a router table—and the other next to one handle. We'd like more routers with this feature.

The Ridgid R2930, with rubber handles, was also easy to grip and use. We like the versatility of the Craftsman 28084's third base, a D-handle fixed



The pole-type switches on Porter-Cable's 895PK give you two options to power up and shut down.

base, for many applications, particularly edge routing and dovetailing. (DeWalt also offers its 618 series in a three-base kit with a D-handle, model #DW618B3, \$279.)

**THE VERDICT:** We don't eliminate any of the remaining 10 kits, but the Bosch (fixed base only), Craftsman 17543, and Hitachi KM12VC get a warning for slick handles.

## Next, look for these ease-of-use features

Because you'll regularly change the motor from one base to the other, don't settle for a kit that makes it difficult.

■ **Straight up is right on.** Fortunately, most of the motors slide straight in and out of their bases with just a flip of a cam-lock and quick-release lever. The DeWalt proved a little tight and difficult to remove. Makita's RF1101KIT requires a screwdriver to tighten a locking screw when switching to the plunge base.

■ **Fixed-base depth adjustments.** Adjusting depth of cut on the fixed bases ranged from easy and intuitive to clumsy and stiff. The Bosch, Milwaukee, Porter-Cable 895PK, and Ridgid deliver the most accurate, repeatable, and easy-to-make adjustments. Each moves straight up and down with a quick release for big changes and a threaded rod for micro-adjustments. You twist the motor in the base to adjust depth on the Hitachi and Makita. They proved accurate, although we didn't like that sometimes the power cord swings around and gets in the way, and the switch moves as well.

■ **Plunge-base use.** All but two (Craftsman 28084 and Hitachi) plunged smoothly. Those two were only slightly

## WHAT GOOD IS A SCALE IF YOU CAN'T READ IT?



The depth scale on the Bosch 1617EVSPK is easy to see when setting plunge depth.



The scale markings on the DeWalt DW618PK are mostly blocked by the depth rod.

stiff, but workable. We felt more in control using spring-loaded plunge-lock levers that you push down to plunge and then release to lock. Bosch, Hitachi, Makita, and Milwaukee have this type. The other plunge bases feature locks that you push down or sideways to lock. Still, all the locks held securely.

Milwaukee's scale proved easiest to read and adjust, followed closely by those on the Bosch (*above*) and Ridgid. The depth scales on the DeWalt and Freud are difficult to read and adjust.

Rotating turret-style depth-of-cut stops, shown *below*, make routing to precise incremental depths easy. Ridgid's single stop adjusts to 32 positions. The Bosch has eight stops, and Milwaukee six, both in  $\frac{1}{8}$ " increments. The DeWalt,

Freud, Hitachi, Makita, and Porter-Cable 895PK have multiple stops, with micro-adjustable settings.

■ **Router-table use.** With each fixed base mounted under a router table, we quickly appreciated the advantage of above-the-table height adjustments, standard on the Bosch, Craftsman 28084, Freud, Milwaukee, Porter-Cable 895PK, and Ridgid. Of these, only the Freud, shown *opposite page*, features a hands-free spindle lock once you engage it with the height-adjustment wrench. With the others, you still need to reach under the table, either to hold in the spindle lock or remove the router motor from the base to change bits.

Whether in a table or not, we prefer two-wrench bit changes to all the one-

wrench routers (except the Freud) because we found it difficult to hold in the small buttons that stop the spindle while also trying to grasp the router and loosen the collet. Routers with two wrenches: Bosch, Hitachi, Makita, Milwaukee, and Ridgid.

**THE VERDICT:** We vote six more kits off the island:

■ The Craftsman 17543 because bit changes proved more difficult with its small collet lock and small wrench, and it was difficult to set bit heights accurately in both bases.

■ Craftsman's 28084 has a stiff plunge action and finicky depth setting, and we've not forgotten its power issues.

■ We had difficulty changing bases and bits with the DeWalt, and its plunge-depth scale (*left*) proved difficult to use.

■ The Freud has no depth scale on its fixed base, and its plunge scale was the most difficult to use. The depth-rod sleeve makes it tough to get to the adjustable turret stops with the required Torx driver. (Freud's Eric Baker says future models will have better scales and an eight-stop turret.)

■ Hitachi's plunge lock is hard to reach without removing a hand from the router, and to release it, we had to push it farther down than we expected. The plunge base also has a stiff spring and finicky depth scale.

■ To change bases, Makita requires a screwdriver instead of an easy-to-use cam lock, and its depth scales on both bases are tougher to use than most.

## TURRET STOPS PROVIDE CONSISTENT DEPTHS FOR PLUNGE ROUTING

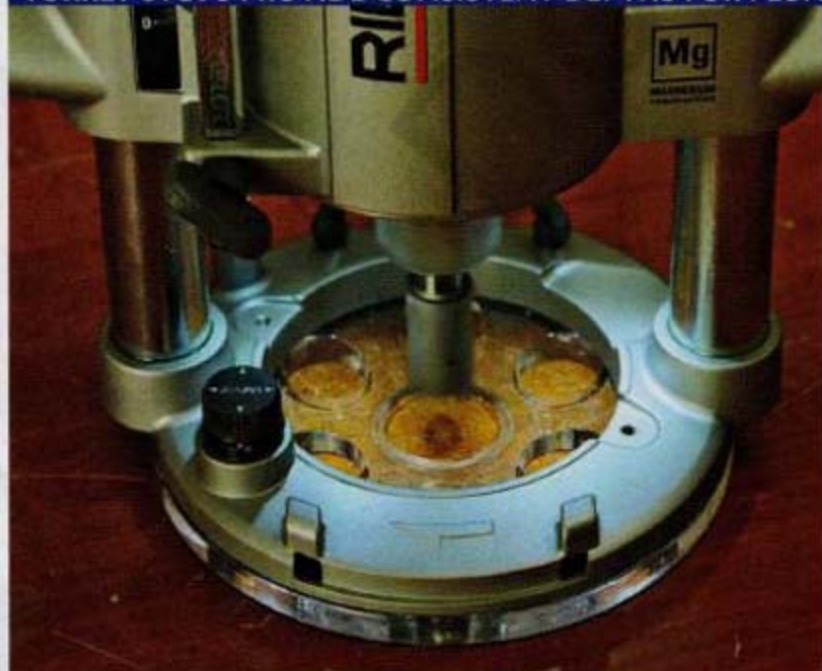

A quarter-turn of Ridgid's turret adjusts cutting depth by  $\frac{1}{64}$ ". The LED light increases visibility of the bit and your workpiece.



You adjust the screws on some turrets, like these two on the Hitachi, for microadjustments. The third stop is not adjustable.

## YOU'LL FIND BIG DIFFERENCES WHEN IT COMES TO CHANGING BITS

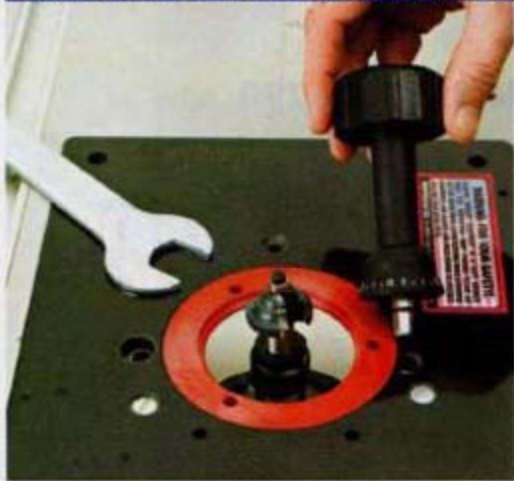

Freud allows bit changes and height adjustments to be made above the table.



Two wrenches give you plenty of leverage to easily break loose the collet to change bits.



With one-wrench changes, you hold the motor as well as the spindle lock and wrench.

### More things you should consider before buying

Now we're down to the four finalists that have distinguished themselves above all the others: Bosch, Milwaukee, Porter-Cable 895PK, and Ridgid.

■ **Variable speed settings.** This is a must-have to safely run larger-size bits at slower speeds. All of these routers have variable speeds, but Porter-Cable and Ridgid mark their dials in rpm numbers. Milwaukee has a speed chart next to its dial—but it has “backlash,” meaning

when changing directions on the dial, we had to turn it three clicks before the motor would change speed. Bosch marks its dial in 1 through 6 increments, but you need to check the owner's manual for corresponding speeds.

■ **Dust collection.** When edge routing, none of the routers gather in all the dust and chips while tethered to a shop vacuum, except for Bosch, which offers an optional collection shield (#RA1170, \$15). But for closed or trapped cuts, such as dados and grooves, they all do a

respectable job collecting the debris. Milwaukee and Ridgid include dust-collection accessories for each base in their kits. We achieved good collection with the hollow column built into Porter-Cable's plunge base and got similar results with the optional fixed-base handle, shown on *page 71*.

■ **Lights.** We like Ridgid's LED lights that couple with the clear subbases to provide better visibility around the bit.

**THE VERDICT:** Warning to Milwaukee for speed-control backlash.

## MEET THE FINAL FOUR CONTENDERS



### Bosch 1617EVSPK, \$220

boschtools.com, 877-267-2499

#### High Points

- ◆ The plunge-base depth scale is among the easiest to read, marked in inches and millimeters.
- ◆ Spring-loaded plunge lock is easily reached without removing your hand from the handle and never slipped during our tests.
- ◆ Clear chip shield on the plunge base flips down for easy access to the collet.

#### More Points

- ◆ Bosch includes an adapter to use its snap-in guide bushings, but you need to buy another adapter to use Porter-Cable-style guide bushings.



### Milwaukee 5616-24, \$250

milwaukeetool.com, 800-729-3878

#### High Points

- ◆ Spring-loaded plunge lock is easily reached without removing your hand from the handle and never slipped during our tests.
- ◆ A rubber grommet over the through-the-base height adjustment keeps dust from plugging the hole.
- ◆ The interchangeable subbases have one opening for Porter-Cable-style guide bushings and the other for larger bits.
- ◆ One of three tested kits with a five-year warranty.

#### More Points

- ◆ The case is a trifold, with the router and second base sitting upright on the middle section. We spilled it a couple of times before we got used to standing it on edge prior to opening.



## Porter-Cable 895PK, \$290

deltaportercable.com, 888-848-5175

### High Points

◆ The power switch has two locations: one near the handles, and another at the top.

◆ Three of the six turret stops are adjustable.

### Low Points

◆ We had to push the plunge-base lock down nearly to its farthest point to lock it in place.

### More Points

◆ This router produced a noticeable vibration, but that did not affect its power or cut quality.

## MULTIBASE ROUTER KITS:

MANUFACTURER	MODEL	MOTOR		COLLET		BASE CONSTRUCTION								PERFORMANCE					
		Speed Range, rpm X 1,000	Electronic Feedback? (Yes, No)	Type (1)	Tightening Method (2)	FIXED BASE				PLUNGE BASE				PRIMARY					
						Subbase Opening, Inches	Base Opening Without Subbase, Inches	Max. Collet Travel, Inches	Height-Adjustment Mechanism (3)	Number of Turret Depth Stops	Max. Plunge Depth, Inches	Subbase Opening, Inches	Base Opening Without Subbase, Inches	Base Shape (4)	Observed Power (6)	Overall Comfort And Control	Lack Of Vibration	Ease Of Changing Bases	Ease Of Changing Bits
BOSCH	1617EVSPK	8-25	Y	SR	2W	2 1/16	3 3/4	2 1/8	QR	8	2 3/8	2 1/16	3 5/16	F	A	A	A	A	A
CRAFTSMAN	17543	12-25	Y	SR	SL	1 1/4	4	1 3/4	QR	4	2 1/2	1 1/4	3 1/4	F	A-	A	A	A	B-
	28084	12-25	Y	SR	SL	1 1/4	4	1 3/4	QR	5	2 1/8	1 3/16	3 1/4	F	B+	A	A	A	B
DEWALT	DW618PK	8-24	Y	SR	SL	1 3/16	3 3/4	1 7/8	C	5	2 1/2	1 3/16	3 9/16	F	A	A	A	B+	B
FREUD	FT1702VCEK	10-23	Y	SR	SL	2	3 11/16	1 7/16	QR	3	2 1/16	2 3/8	3 11/16	R	B-	A	A	A	A
HITACHI	KM12VC	8-24	Y	SR	2W	1 3/4	3 3/8	1 9/16	RM	3	2 9/16	1 3/4	3 9/16	R	A	A	A	A-	A-
MAKITA	RF1101KIT	8-24	Y	SR	2W	1 3/16	3 7/16	2	RM	3	2 9/16	1 3/16	3 7/16	R	A	A	A	B-	A
MILWAUKEE	5616-24	10-24	Y	SR	2W	2 1/2	3 3/16	1 7/16	QR	6	2 7/8	1 5/16	3 5/16	R	A	A	A	A	A
PORTER-CABLE	694VK	10-27.5	N	SR	2W	1 3/16	3 3/4	1 7/8	RM	6	2 1/2	1 3/16	3 3/4	R	C*	A	A-	B-	A
	895PK	10-23	Y	SR	SL	2 1/2	3 7/8	2 1/8	QR	6	2	1 3/16	3 5/8	F	A	A	A-	A	B-
RIDGID	R2930	10-23	Y	SR	2W	2 1/2	3 5/8	2 3/8	QR	32	2 5/16	1 3/16	3 5/8	F	A	A	A	A	B+
SKIL	1825	10.5-25	N	NR	SL	2 1/16	4 1/2	1 1/2	QR	2	2	2 1/16	3 1/2	F	D*	C	B-	B	A

1. (NR) Non-self-releasing  
(SR) Self-releasing

(SL) Spindle lock and one wrench  
2 wrenches

3. Adjust with quick

4. Motor

4. (F) Round with a flat edge  
(R) Round

5. 

A	Excellent
B	Good
C	Fair
D	Poor
NA	Not available on this model

6. Measured with a phototachometer while routing a 3/8"-deep bead and cove profile on a router table.  
\* No electronic feedback control



## Ridgid R2930, \$200

ridgid.com, 866-539-1710

### High Points

- ◆ This router has the longest power cord at nearly 12 1/2'.
- ◆ Each subbase has a flat edge for routing against a straightedge. One subbase fits Porter-Cable-style guide bushings.

### Low Points

- ◆ The side-to-side plunge lock—mounted on the right side—is awkward to use, as you push toward the motor to release it and pull toward the handle to lock it.

### More Points

- ◆ The heavyweight-fabric bag allows for quick repacking, but we'd like it a little bigger to make room for accessories.
- ◆ Customers will receive a lifetime service agreement from Ridgid when they register their router within 90 days of purchase.

## TWO BASES ARE BETTER THAN ONE

RATINGS (5)											ACCESSORIES (7)		WEIGHT, LBS		Cord Length, Feet	Warranty, Years	Country of Assembly (8)	Selling Price (9)	
SECONDARY											Standard	Optional	With Fixed Base	With Plunge Base					
FIXED-BASE USE					PLUNGE-BASE USE														
Setting Cutting Depth	Depth-Scale Readability	Depth-Scale Accuracy	Dust Control	Router-Table Use	Plunge Smoothness	Plunge-Lock Reliability	Ease Of Adjusting Depth Stop	Depth-Scale Readability	Depth-Scale Accuracy	Dust Control	Ease Of Repacking Case								
a	a	a	b+	a	a	a	a	a	a	a	b	A,W	C,D,E,G	8.7	10.4	10.1	1	M	\$220
b	a	a	b	b	a	a	a	b	a	a	b-	D,E	C,G,S	8.4	9.9	8.0	1	C	\$120
b	a	a	b+	a	b	a	a	b	a	a	a-	D,E,H,W	C,G,S	8.8	10.5	10.0	1	C	\$220
b	a	b	na	b	a	a	b	c	b	a	a	C,D,S	E,G,H	8.2	10.9	8.2	3	M	\$220
b	na	na	b	a	a-	a	c	c	c	a	b	A,D,W	E,G	9.3	10.7	9.5	5	S	\$200
a	a	a	b+	b-	b	a	a	b	b	a-	b	A,C,G,S	D,E	7.3	9.9	8.7	5	C	\$180
a	b	a	b	b	a	a	b	b	b	a-	a		D,E,G	7.9	9.9	8.5	1	U	\$220
a	a	a	b-	a	a	a	a	a	a	a-	a-	C,D,W	E,G,S	8.9	11.4	8.0	5	U	\$250
a	a	a	na	c+	a	a	a	a	a	na	b		E,G,S	8.1	11.2	7.1	3	M	\$220
a	a	a	b	a	a	a	a	b	a	a	b	C,W	D,E,G,S	8.8	11.9	10.1	3	M	\$290
a	a	a	b+	a	a	a	a	a	a	a	a	C,D,W	E,G	9.2	11.9	12.3	3	C	\$200
c	c	c	b	c-	b-	a	a	c	b	a-	a		D,E,G	8.2	9.4	6.5	1	C	\$100

## Here's where we'd route our router dollars

We could find no serious flaws with the Bosch 1617EVSPK, so it gets our nod as Top Tool. It has outstanding power, easy-to-read and easy-to-use depth scales on both bases, a smooth plunge action, through-the-base height adjustments, an eight-stop turret, and two thick forged wrenches for easy bit changes. The Milwaukee 5616-24 is powerful and comfortable to use, but the backlash-like unresponsiveness in the variable-speed dial relegates it to a close second.

Although it didn't make our final four list—it's somewhat difficult to change bits and set bit heights—we found the Craftsman 17543 provides decent performance for a low price. It gets our Top Value award. For \$120, you get a router with good power that slides into and out of its bases easily and includes clear subbases, an LED light, an edge guide, and dust-collection attachments. The subbase openings are molded for guide bushings, so you'll need to spend \$20 more to get subbases for larger bits. 📌

Written by **Bob Hunter** with **Randy Zimmerman**

## Craftsman 17543, \$120

craftsman.com, 800-349-4358



7. (A) Subbase adapter for guide bushing  
 (C) Centering cone  
 (D) Dust-collection attachment  
 (E) Edge guide  
 (G) Guide bushing  
 (H) D-handle base  
 (S) Additional subbases  
 (W) Router-table depth-adjustment wrench

8. (C) China  
 (M) Mexico  
 (S) Spain  
 (U) United States

9. Prices are typical street prices current at time of article production and do not include shipping, where applicable.

# Fun and Fancy Yo-Yo

Are cutoffs of exotic wood collecting dust in your shop?

Here's your chance to transform a few pieces into an eye-catching toy.

The kit includes a special mandrel that makes turning one child's play.



## 1 Gather the materials

For this project, you'll need the supplies shown *below*. (For the mandrel, yo-yo hardware, stone inlays, 35mm Forstner bit, and an inexpensive drill chuck, see **Source**, on *page 78*.) Using a compass, draw two 3"-diameter circles on the same piece of  $\frac{3}{4}$ "-thick figured stock. To make the template, photocopy the yo-yo pattern at *right*, adhere it to cardboard with spray adhesive, and cut it to shape.

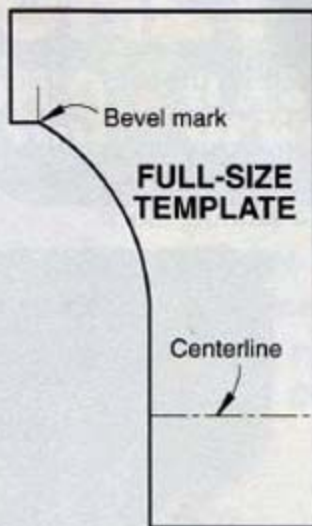

## 2 Install the aluminum hubs

Chuck a 35mm Forstner bit into your drill press. Centering the bit on the compass center mark, drill a  $\frac{3}{8}$ "-deep hole in each circle, as shown *below*. Test-fit the aluminum hubs to make sure they are flush with the surface. Bandsaw the blanks to shape, staying slightly outside the lines. Spread a thin layer of quick-setting epoxy around the side of each hole, and press the hubs into place, smooth side out.

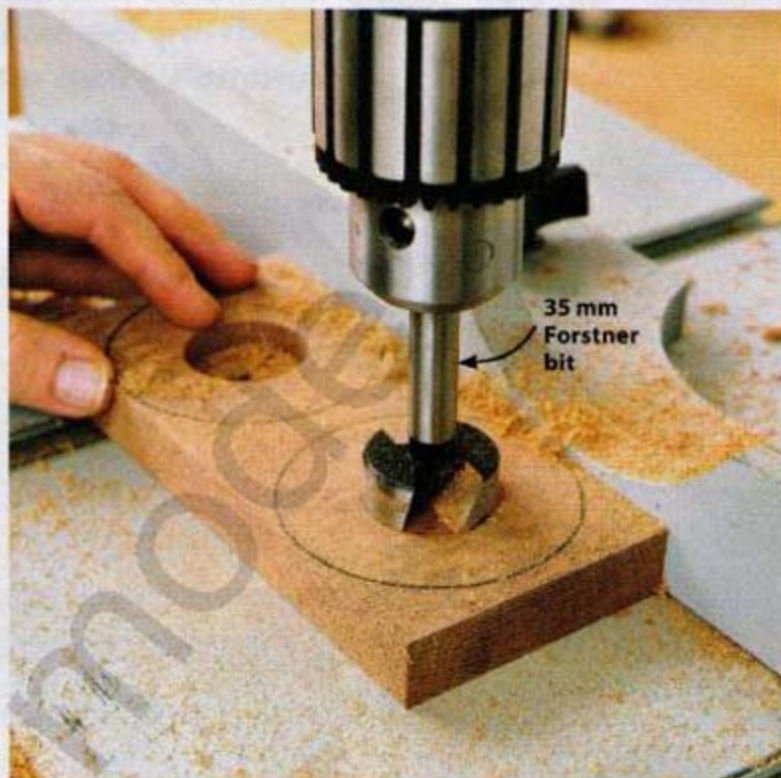

## 3 Mount and true the blanks

**Tool:**  $\frac{3}{8}$ " or  $\frac{1}{2}$ " bowl gouge.  
**Tool rest:** Slightly below center.  
**Speed:** 1,800 rpm.

Install a drill chuck in the lathe headstock, and chuck in the mandrel. (If the machine screw turns in the mandrel, apply liquid thread locker, such as Lock-

tite.) Then screw one blank onto the mandrel, and mark the center with the lathe tailstock center. Next, draw a  $2\frac{5}{8}$ "-diameter circle on the face of the blank. Engage the lathe tail center, and use a bowl gouge to true the blank edge to finished diameter, as shown *below right*.

Now back away the tailstock. Making light pull cuts from the center to the edge with your bowl gouge, true the face of the blank, and turn it to the  $\frac{5}{8}$ " finished thickness. Mount and true the second blank.

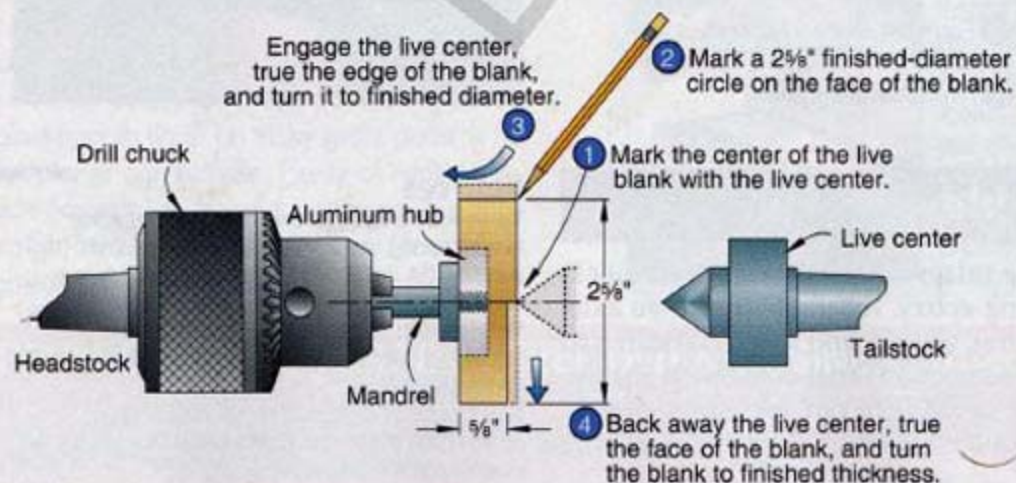

## 4 Shape the yo-yo disks

**Tool:**  $\frac{3}{8}$ " or  $\frac{1}{2}$ " bowl gouge.  
**Tool rest:** Slightly below center.  
**Speed:** 1,800 rpm.

On the edge of the blank, make a mark for a bevel  $\frac{1}{8}$ " from the back face, where shown *below*. Making pull cuts from the center to the edge with your bowl gouge,

form the outside profile of the yo-yo disk, as shown *below right*. Make light cuts and check the profile with the template. To avoid tearing out the back edge of the disk, stop your gouge cuts at the  $\frac{1}{8}$ " bevel line. To reduce string wear, use 150-grit sandpaper and a sanding block

to form the  $\frac{1}{8}$ " bevel. Mount the second blank and repeat these steps to form the second disk. For proper balance of the finished yo-yo, make sure the diameter, thickness, and profile of each disk is exactly the same.

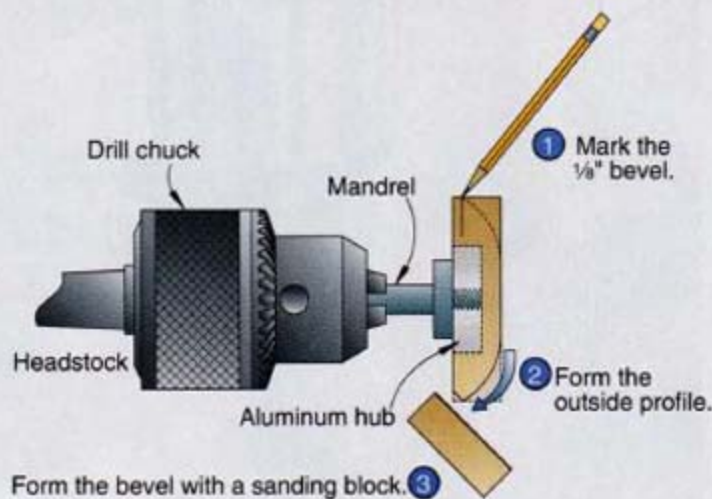

## 5 Form recesses for the stone inlays

**Tool:**  $\frac{3}{4}$ " skew chisel.  
**Tool rest:** Slightly above center.  
**Speed:** 1,800 rpm.

Mark the disk center with the lathe tail center. Measure the diameter of the stone inlay, and draw a circle of this diameter on the blank. Using a skew chisel as a scraper (placed flat on the

tool rest with the cutting edge trailing), cut a  $\frac{1}{8}$ "-deep recess for the inlay, as shown at *right*. Make light cuts and sneak up on the marked line, checking the recess with the inlay for a snug fit. Finish-sand the front and back of the disk and the bevel to 320 grit. Mount the second blank and repeat.

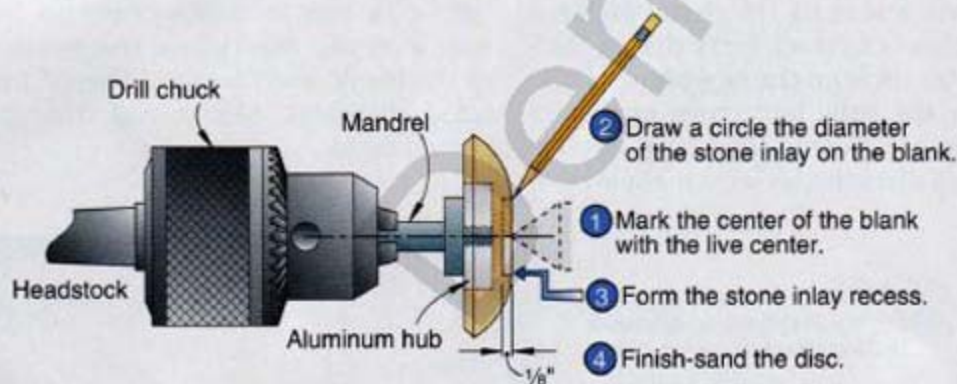

## 6 Apply a finish and assemble

With each disk mounted, in turn, on the mandrel, apply sanding sealer. One coat is sufficient for close-grained woods. Apply two coats to open-grained species, sanding between coats. Sand the final sealer coat with 320-grit sandpaper, and apply a shellac/wax finish, such as Mylands Friction Polish. Avoid getting finish into the inlay recess. Remove the disks from the mandrel and mount the

stone inlays with a few drops of quick-setting epoxy. Assemble the yo-yo axle, bearing, washer, and string according to the instructions that come with the kit. Now see if you can execute a perfect "around the world," or maybe "walk the dog" across the carpet. 🌲

Written by **Jan Svec**  
Project design: **Phil Brennon**  
Illustrations: **Roxanne LeMoine; Lorna Johnson**

### Sources

**Yo-yo kit.** Hardware for one yo-yo, mandrel, stone inlays (2), string, kit no. 950-7083, \$22.99 ppd. Craft Supplies USA. Call 800-551-8876, or go to [woodturner-catalog.com](http://woodturner-catalog.com).

**Forstner bit.** 35mm Forstner bit no. 995-7083, \$12.99 ppd. Craft Supplies USA, see phone number and Web address above.

**Drill chuck.**  $\frac{1}{2}$ " drill chuck with #2 Morse taper no. 964-7300, \$24.99 ppd. Craft Supplies USA, see phone number and Web address above.

Also check out Packard Woodworks for turning supplies. Call 800-683-8876, or visit [packardwoodworks.com](http://packardwoodworks.com).



# 4-WAY MONEY MAKER

## MOLDS • PLANES • SANDS • SAWS



- Shape 3 sides per pass!
- Choose from 500+ Patterns!
- RISK FREE 30-Day Trial Offer!



Now, turn a \$5.00 rough board into \$75.00 worth of high-dollar molding in just minutes. Make over 500 standard patterns, curved molding, tongue & groove, picture frame stock, any custom design. QUICKLY CONVERTS from Molder/Planer to Drum Sander or power-feed Multi-Blade Ripsaw. Made in U.S.A. 5-Year Warranty. Choose from 12", 18" or 25" models.

### Variable Feed Makes the Difference!

Just a twist of the dial adjusts the Woodmaster from 70 to over 1,000 cuts per inch. Produces a glass-smooth finish on tricky grain patterns no other planer can handle. Plenty of American-made "muscle" to handle money-saving, "straight-from-the-sawmill" lumber. Ideal for high-value curved molding.

### Custom Woodworker has Competitive Edge Thanks to Woodmaster

WATCH Gary Striegler make curved molding: visit [www.woodmastertools.com](http://www.woodmastertools.com)  
 "Woodmaster really changed the way I do woodworking. It set my career in the right direction. Making curved molding with the Woodmaster really separates me from my competition - it's like a PhD in woodworking."  
 - Gary Striegler, President, Striegler & Associates Custom Homebuilders



### SHAPE 3 SIDES IN 1 PASS!



NEW 3-Side Molding System turns your Woodmaster into a POWERFUL 3-SIDE MOLDER that efficiently & AFFORDABLY cuts T&G flooring, paneling, much more!

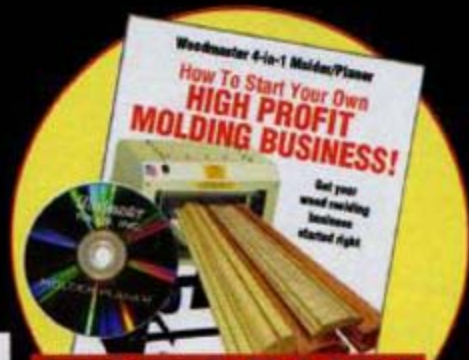

**FREE DVD!**  
 Call Toll-Free 1-800-821-6651  
 Ext. P337

### The Woodmaster Molder/Planer is a MOLDING FACTORY!



**Quick-Change Molding Head** lets you create custom molding from any stock. Choose from over 500 standard trim and picture frame patterns...or design your own!



**Commercial-Duty Thickness Planer** features infinitely variable feed rate. Use higher speeds for fast stock removal... slow down to get over 1,000 cuts per inch for fine finish passes.



**Power-Feed Drum Sander** saves hours of tedious hand sanding. Speeds production, improves quality. No more waves or cross grain scratches.



**New Ripsaw Attachment** lets you gang rip with power feed in a fraction of the time it takes for hand-fed passes on an ordinary table saw.

## HURRY! CALL NOW FOR YOUR FREE DVD & BUSINESS STARTER KIT!

CALL TODAY and we'll RUSH you our new Woodmaster DVD & Business Plan! You'll learn exactly how to start & operate a profitable molding business! Includes business plan, instructive DVD, full specs, prices, LIMITED-TIME SAVINGS OFFER, and info on easy financing.

**CALL TOLL FREE 1-800-821-6651** Ext. P337

Woodmaster Tools, Inc. Dept. P337, 1431 N. Topping Ave., Kansas City, MO 64120 • [www.woodmastertools.com](http://www.woodmastertools.com)



# The Eyes Have It!

Doing your best work means seeing your best. These six products help you do just that.

**W**oodworking can be hazardous to your vision, what with dust and such flying around. That's why we always wear eye protection when working with power tools. Unfortunately, all the safety gear in the world can't protect our eyes from aging, and all those little lines on rulers and gauges begin to blur after age 40. If your cutting tools are sharper than your vision, stick around and you'll learn some great ways to see your way clearer.

## First, sharpen the image

Full-face shields easily cover prescription eyeglasses, but woodworkers who don't wear prescription glasses sometimes still need a bit of help reading tape measures and other fine markings. Manufacturers are stepping up to the plate by combining safety glasses with built-in reading lenses in products, such as CatEyes Magnifying Bifocal Safety Glasses (\$7, 888-443-3748, fastcap.com), shown in **Photo 1**, above. They're not truly bifocals because the upper viewing field is uncorrected, but the lower magnifying section functions just like those on traditional bifocals. They come in standard magnifications from 1.5x to 3.0x.

But what if you already have a favorite pair of safety glasses, or if your regular glasses correct for distance? Not a problem. The Optx20/20 system (\$20, 800-344-2020, optx2020.com), shown in **Photo 2**, uses stick-on lenses to create bifocals on any glasses or face shield. The thin, pliable semicircles stick to any

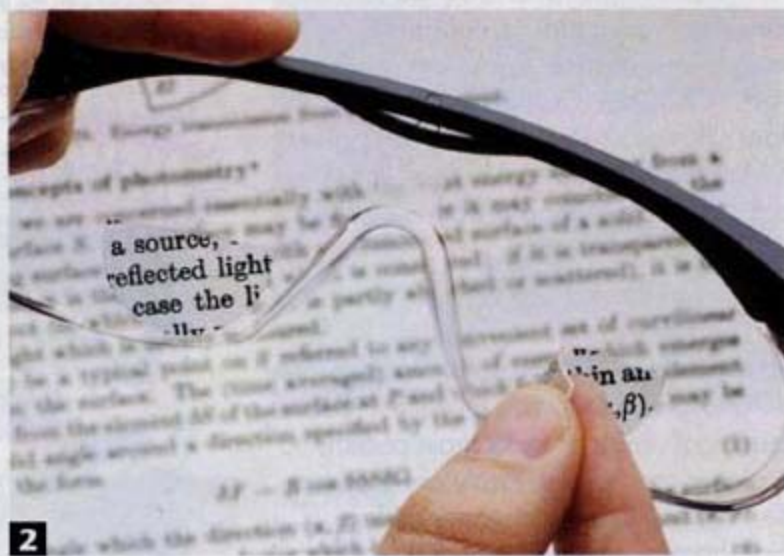

smooth, glossy surface and come in magnification ranges from 1.25x to 3.0x.

## Now, enlarge the view

Of course, you might already wear prescription bifocals. Or you just may need some extra magnification for finely detailed work. To make small things look bigger, nothing's better than a hands-free magnifying glass. One way to do that is with a magnifying visor, such as the one in **Photo 3**. The OptiSIGHT



3



4



5



6

(\$30, 913-492-2500, doneganoptical.com) combines a headband—like the type used in face shields, but much lighter—with interchangeable acrylic lens plates. The visor can be worn over prescription glasses and tilts up out of the way when not needed. The visor includes lens plates in 3×, 4×, and 5× magnifications, and an optional 7× lens plate is also available.

Increasing the amount of light on a subject helps you see it better, too. When you need both magnification and more light, it's hard to beat a simple magnifying light [Photo 4]. Available just about everywhere, including craft and discount stores, it comes with a clamp-on base that also can be screwed into place. An articulated arm allows the lighted lens to be placed anywhere within its reach. Prices range from a mere \$12–\$15 for basic lights using ordinary incandescent bulbs up to models with circular fluorescent tubes costing from \$60–\$100. Unless you have a specific need for a high-end unit, however, the low-cost lights usually do the trick.

### Brighten things up

The quality of shop light affects how your eyes perceive color. During finishing, you want to accurately see the color of the wood, any stain you may use, and any additional coloration lent by the final topcoat. However, the ubiquitous fluorescent lights found in most shops don't always give a natural appearance. That's why a project may look one way in the shop but entirely different elsewhere.

For viewing true colors, step up to “daylight” fluorescent lighting [Photo 5], which better simulates nature. The key is the color rendering index, or CRI, a zero-to-100 scale that rates light output relative to normal sunlight. The noonday sun has a CRI of 100, and the closer you can get to that number, the more accurate the color of your projects. Consider a CRI of 80–90 good enough for your shop.

Likewise, take a look at the color temperature, a rating measured in degrees Kelvin (K) compared with sunlight. A color temperature range of 6,200–6,800 degrees K is closest to actual daylight. Both the CRI and the color temperature should be listed on the packaging.

Of course, if your goal is to simulate daylight, why not go for the real thing? Natural light is a huge boon in the shop, and if you have the luxury of designing your shop from scratch, be sure to include windows. For windowless shops, consider adding a skylight, such as the Solatube Daylighting System (888-765-2882, solatube.com), a self-contained skylight [Photo 6] that adapts to almost any roofline and ceiling. Its exterior dome captures light from multiple angles, focuses it into a reflective tube, and delivers the light along an angled path. Installation proves easier than regular skylights, and requires a minimum of cutting. A typical system like the one shown starts at about \$300. 🌱

Written by **A.J. Hamler**

SHOP TESTED

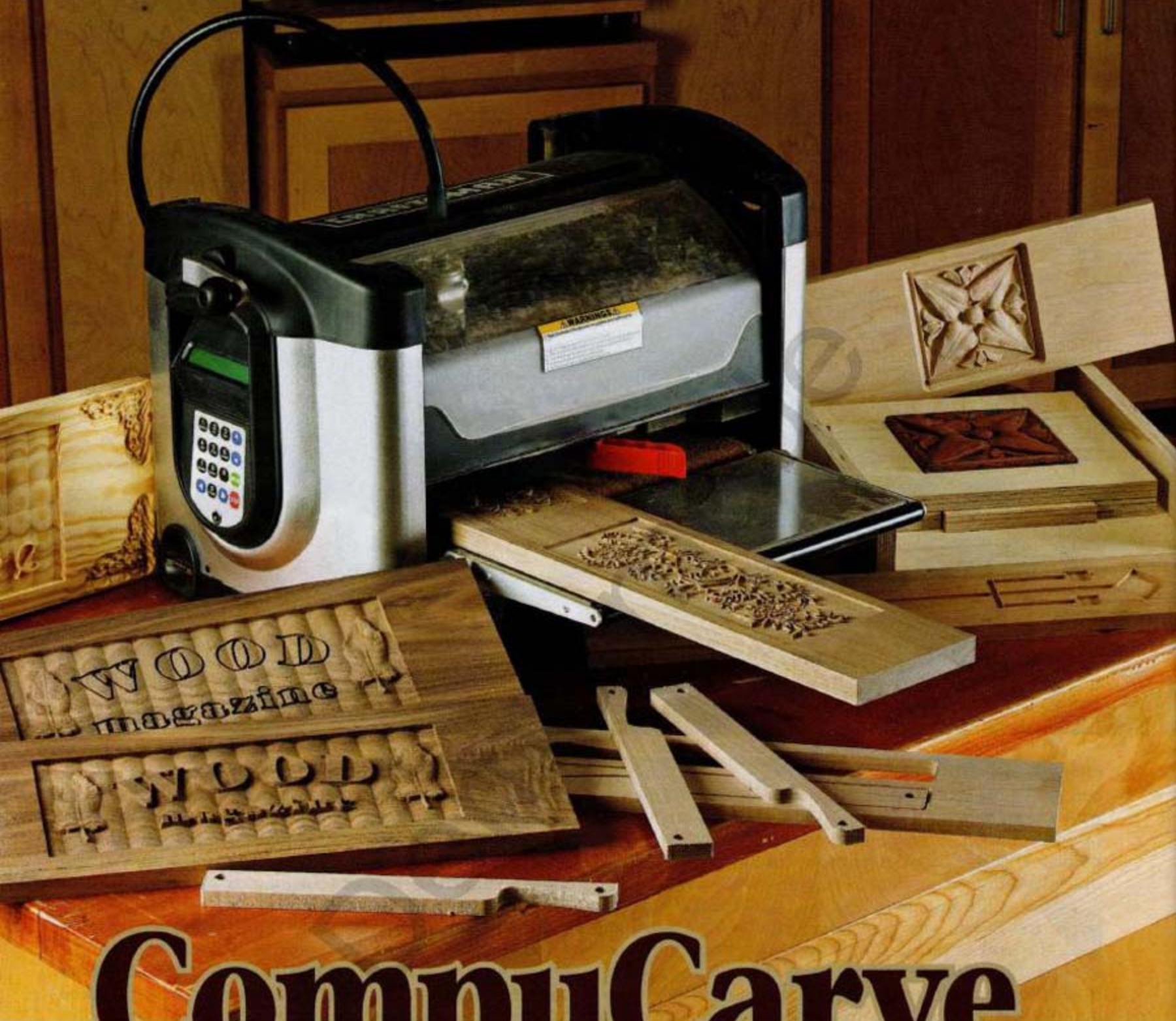

# CompuCarve

Bring 3-D carving into your workshop for the price of a cabinet-style tablesaw.



View a FREE video of the CompuCarve in action at [woodmagazine.com/compu carve](http://woodmagazine.com/compu carve)

It doesn't happen often, but every once in a while a manufacturer comes along with a tool that's truly revolutionary in its design, function, or price. Such is the case with the new Craftsman CompuCarve (sold also by CarveWright at [carverwright.com](http://carverwright.com)), a computer-numerically-controlled (CNC)

milling machine that looks like a benchtop planer. We call it revolutionary because although its price (\$1,900) isn't for the budget-conscious among us, that's a lot less than CNC routers that typically sell for five figures and up.

So what do you get for that money? At the very least the CompuCarve can cre-

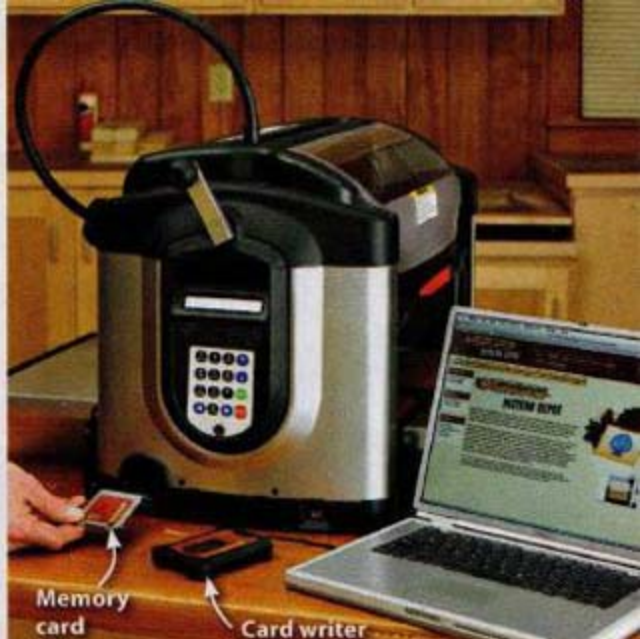
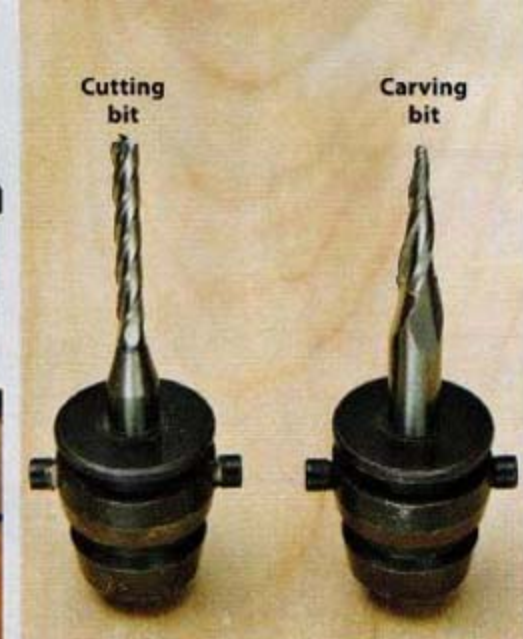
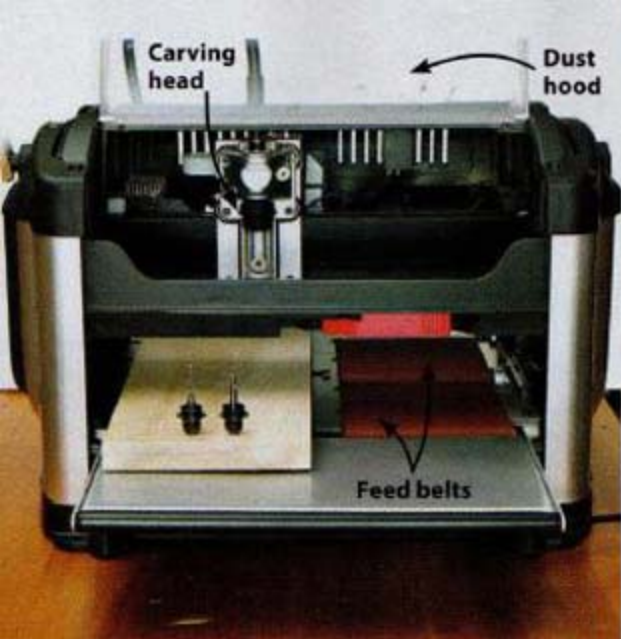

## YOUR COMPUTER DOES THE THINKING; THE BITS DO THE DIRTY WORK

CompuCarve's carving head works similar to a desktop printer, while the feed belts move your workpiece forward and backward.

The  $\frac{1}{8}$ " spiral cutting bit creates edges perpendicular to the workpiece face. The carving bit makes beveled and stepped cuts.

Load your designs onto the memory card to transfer the carving instructions from your computer to the CompuCarve.

ate signs—as simple or elaborate as you want. A signmaker who currently uses hand tools or a router will quickly recoup his investment on time savings alone. But can it just as easily crank out project parts in quantity? After a couple of months of intense testing, the answer is a qualified “yes,” but before we get to that, some explanation is in order.

### Here's how it works

Inside the CompuCarve a carving head (essentially a small router) on a sliding carriage, shown *above*, moves on two axes: up and down, and side-to-side. Abrasive feed belts—like those on a drum sander—feed your workpiece in and out of the machine. The precise coordination of these three movements makes carving and cutting any shape possible. Bits mounted in bayonet-style

collets—the machine comes with a tapered carving bit and a  $\frac{1}{8}$ " spiral cutting bit, shown *above*—snap into the carving head. The CompuCarve can mill workpieces up to 5" thick, 14½" wide, and 12' long (but you'll need infeed and outfeed support for stock longer than 4').

The machine relies on special software, and that's where your computer comes in. To run the CompuCarve you'll need a reasonably up-to-date operating system on your computer. Minimum requirements for a PC include Windows 2000; Macintosh users must have OS10.3 or newer software. Go to [craftsman.com](http://craftsman.com) for specific software needs.

Begin by creating your own design (more on that later) or choosing one from the CompuCarve library. Save it onto the memory card using the card

writer, shown *above*. Then insert the card into the machine. Next, install the appropriate bit, place your workpiece into the unit, and press the start button. The CompuCarve measures the width and length of your workpiece and then carves the design. Your computer will estimate the carving time based on the complexity of the design. The machine tells you which bit to use for specific tasks, and if a job takes both it will carve all it can with one bit before stopping to allow you to switch bits.

Included with the software package are a dozen drop-and-click designs, brackets, rosettes, and other decorative motifs. Supporting all this is the CarveWright Web site ([carvewright.com](http://carvewright.com)) that provides a project gallery, user forum, design pattern store, and product and software updates.

## Helpful tips to get you started

We learned a lot during our extensive testing of the CompuCarve:

- Users should depend on the helpful CarveWright Web site as an extension of the owner's manual and for helpful tips and software updates.
- Initially, be prepared to spend a lot of time at the computer. Practice will hone your skills and reduce the frustrations we sometimes encountered as we became familiar with the software.
- Rather than designing your own projects from scratch with the CompuCarve software, sketch out your design on graph paper (including dimensions). Then redraw it on the computer using a grid applied to the “virtual board,” and you'll save time.

- Make experimental cuts in MDF or scrapwood before using—and potentially ruining—your good stock.
- Cover workpieces prone to grain tear-out with masking tape before carving to help reduce tear-out, as shown at *right*.
- There's no dust collection on this machine, only a small port with a dust bag that vents the motor fan. (This port seldom vents dust.) To keep the machine running smoothly we recommend thoroughly removing dust and shavings with a vacuum and compressed air after each carving.
- Although costly, some accessories, such as the scanning probe (\$300), extra bit set (\$300), and Centerline Text lettering program (\$100), proved worthwhile.

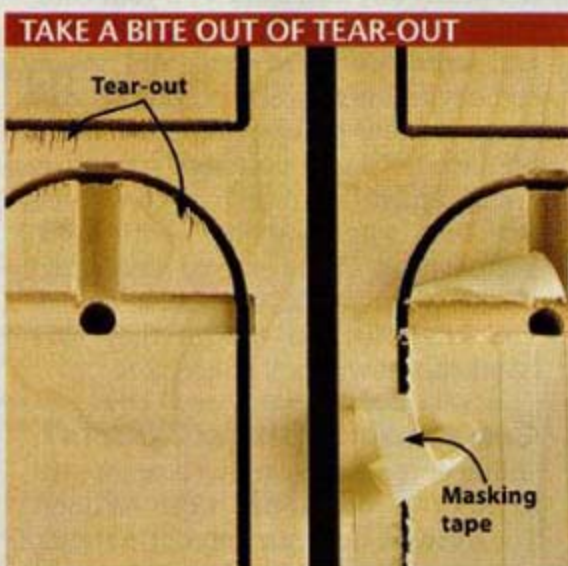

We cut out these project parts from birch plywood. The one on the left suffered tear-out, but the tape prevented it on the other.

Vector-mode lettering,  
raster-mode relief carving,  
1 hour, 43 minutes

Raster-mode  
lettering and  
relief carving,  
1 hour,  
23 minutes

Centerline Text  
lettering and  
raster-mode  
relief carving,  
45 minutes

### SIMPLE WORKS BEST

Of CompuCarve's three lettering modes, we preferred the quick and easy-to-read work done with the Centerline Text accessory package.

### It's a signmaker's dream

Most of the time the CompuCarve routs out its design—whether lettering, graphics, or decorative design—using a *raster-based* pattern. That means it removes material line by line as the spinning carving bit moves across the workpiece, getting deeper with each pass, similar to how a desktop printer takes several passes across a page to print one line of type. The other mode is *vector* carving, where the spiral bit routs in  $\frac{1}{8}$ "-deep increments from point to point, like a connect-the-dots puzzle. This mode proved best for cutting project parts.

Although the CompuCarve will render nearly any font loaded on your computer, avoid fonts with narrow lines and serifs—the pointy ends and tips on some type fonts—when carving because those delicate portions of letters break off easily. An accessory software enhancement we tested called Centerline Text, when combined with a 60° V-groove bit (\$20), carved faster and cleaner than raster and vector modes. The letters look as though they were hand-carved with a V-gouge, too.

### Can it make project parts?

Going beyond sign carving is not for the timid or impatient, but it can be done. The software does not import CAD files, and we found the drawing tools in the CompuCarve's Designer software cumbersome and the learning curve steep.

After several failures with a complex part, we tried to duplicate the much simpler parts for the knife rack *above right* and on *page 94*. Eventually, we got the CompuCarve to cut out six parts in 45 minutes, but the edges needed a fair amount of cleanup and sanding.

The CompuCarve requires material that's jointed and planed on all surfaces. Although it will rip and crosscut workpieces as it claims, it takes longer for that  $\frac{1}{8}$ "-diameter bit to make the series of incremental cuts necessary to do the job versus using a tablesaw. (It took 15 minutes to mill a  $\frac{3}{4}$ "-thick board square and true to 6"×3'.) And the chatter marks left on the edges and ends need significant sanding or planing. You're better off to use your tablesaw and a sharp blade.

### You copy me?

Upgrades for the CompuCarve are many and pricey, but for copying profiles or relief carvings, the scanning probe accessory is worth it. This device mounts into the carving head and lightly drags a pointed probe back and forth over the surface of a three-dimensional object, such as an escutcheon plate, relief carving, or rosette, as shown at *right*. The probe creates a 3-D "map" of the object and loads it onto the memory card. You then can import the image into the computer to reproduce it in a project. (It took three hours to scan the rosette, and another 55 minutes to carve it.)



### RACK 'EM UP

The CompuCarve leaves tiny tabs that keep these knife rack parts from breaking loose and getting damaged during machining.

### The bottom line

Like almost all innovative tools that have no peer, the CompuCarve comes at a premium price that will likely turn away many interested consumers. We all have to justify our tool purchases, and this is more than a simple impulse buy. So it's probably not for someone who'll make a couple of signs and then shelve it. That said, the CompuCarve performs tasks—some with minimum user input—that no other machine in its price range can do. If you make lots of signs or regularly incorporate decorative or carved elements into your projects, then you'll love this machine and should have no trouble realizing its value. 🌲

Written by **Bob Hunter** with **Jan Svec**

### GETTING A FEEL FOR IT



The scanning probe glides across an antique terra-cotta rosette, recording the shape and contours, then saves it on the memory card.



# COMBINE YOUR CREATIVE TALENTS AND PRACTICAL SKILLS.

## Learn Furniture & Cabinet Making at Home with Penn Foster.

Despite the development of plastics and composite materials, there is still a demand for wood products by home owners and contractors. Helping to meet this demand are highly skilled woodworkers who perform the cutting, shaping, preparation, and assembly of wood components into a finished product.

**Job-focused program.** In as little as six months, Penn Foster can train students for employment in the woodworking profession. Furniture and Cabinet Makers work for furniture dealers, retail stores, and cabinet manufacturers; re-upholstery, furniture and cabinet repair shops; and home improvement stores. Some open their own woodworking shops and specialize in custom furniture and cabinet making.

**Flexible method of study.** You choose the time and place to complete your coursework, and you work at your own pace. All learning materials are delivered right to you. You can study online, in print, or a combination of both. You decide which method best suits your learning style.

**Network of support.** With Penn Foster you work independently, but not alone. Expert instructors and a helpful support staff are just a phone call or an email away.

**Accreditation.** Penn Foster Career School and Penn Foster College are accredited by the Distance Education and Training Council (DETC). Penn Foster Career School is also accredited by the Middle States Commission on Secondary Schools for its high school and vocational-technical programs.

**Affordable tuition.** Penn Foster's tuition rates are among the lowest of all schools. We offer 0% APR financing and customized payment plans to best meet your individual need.

**For FREE Information:**

Call toll free **1-800-572-1685** ext 6144

Or visit **www.PennFoster.edu**

Online enter ID# AW8558T

Or mail the coupon or postage-paid card today!

You'll receive a **FREE Career Catalog**. Learn about exciting new career choices and rewarding job opportunities!



### PENN FOSTER CAREER SCHOOL

925 Oak Street, Scranton, PA 18515-0700  
www.PennFoster.edu

**384 Furniture & Cabinet Maker**

**Other Vocational Programs:**

**Building Trades**

- 104 Carpenter
- 06 Electrician
- 15 Home Inspector
- 145 Home Remodeling & Repair
- 151 Plumber
- 102 Professional Landscaper

**High School**

- 07 Penn Foster High School

**Finance & Business**

- 390 Bookkeeping
- 70 Small Business Owner

**Technology**

- 51 AutoCAD®
- 105 Computer Graphic Artist
- 79 Electronics Technician
- 27 PC Maintenance and Repair
- 83 Web Page Designer

**Mechanics**

- 04 Auto Repair Technician
- 55 Diesel Mechanics
- 14 HVAC Technician
- 33 Motorcycle Repair Technician
- 89 Small Engine Repair

**Other Exciting Programs**

- 30 Floral Design
- 05 Hotel/Restaurant Management
- 12 Interior Decorator
- 58 Private Investigator
- 31 Professional Locksmithing
- 26 Teacher Aide
- 35 Travel/Tourism Specialist
- 22 Wildlife & Forestry Conservation



### PENN FOSTER COLLEGE

Administrative Office  
14300 N. Northside Blvd, Suite 111  
Scottsdale, AZ 85260  
www.PennFosterCollege.edu

**Associate Degree Programs:**

- 61 Accounting
- 60 Business Management
- 418 Computer Information Systems

- 406 Criminal Justice
- 405 Early Childhood Education
- 65 Electrical Engineering Technology
- 67 Electronics Technology
- 81 Finance
- 407 Graphic Design
- 409 Health Information Technology
- 412 Human Resources Management
- 80 Marketing
- 62 Mechanical Engineering Technology
- 427 Medical Assistant
- 408 PC Maintenance Technology
- 396 Veterinary Technician

Please send me **FREE** information on the Career School or College program I have selected above. No obligation. Choose **ONE** only.

Name \_\_\_\_\_ Age \_\_\_\_\_

Street \_\_\_\_\_ Apt.# \_\_\_\_\_

City/State \_\_\_\_\_ Zip \_\_\_\_\_

Phone ( ) \_\_\_\_\_

Email \_\_\_\_\_

Mail coupon to Student Service Center\*, Dept. AW8558T,  
925 Oak Street, Scranton, PA 18515-0700.

\* Under contract with Penn Foster College, AZ



Understan... I SAID...

# UNDERSTANDING SHOP NOISE!

Follow these guidelines to protect your hearing.

**T**here's no denying that power tools make your woodworking easy. But there's also no avoiding the fact they can rob you of your hearing. The good news: Noise-induced hearing loss is 100-percent preventable.

To learn more about how hearing loss occurs, and which products best help you ward it off, we consulted several experts in the field, and tested a number of hearing protectors. Follow these tips and you'll have no problem hearing all the wonderful compliments about your woodworking for many years to come.

## How loud is too loud?

We measured the sound level of various machines and tools in use with a decibel (dB) meter. (See how tools compare to everyday noises, *below*.) Of the 50 tools we measured, 26 produced noise that exceeds the 85-dB level where hearing damage begins to occur in most people during exposure over regular daily intervals.

Additionally, 18 of those tools exceeded 90 dB, where hearing damage occurs in just 2½ hours, and six topped the 100-dB mark that induces hearing damage after only 15 minutes of regular exposure.

Will a couple of minutes working without hearing protection at 85 dB

cause damage? Probably not, but Mark Stephenson of the National Institute for Occupational Safety and Health (NIOSH) warns that people with sensitive ears could suffer damage in a noisy environment quicker than most people. And regular exposure to those levels would

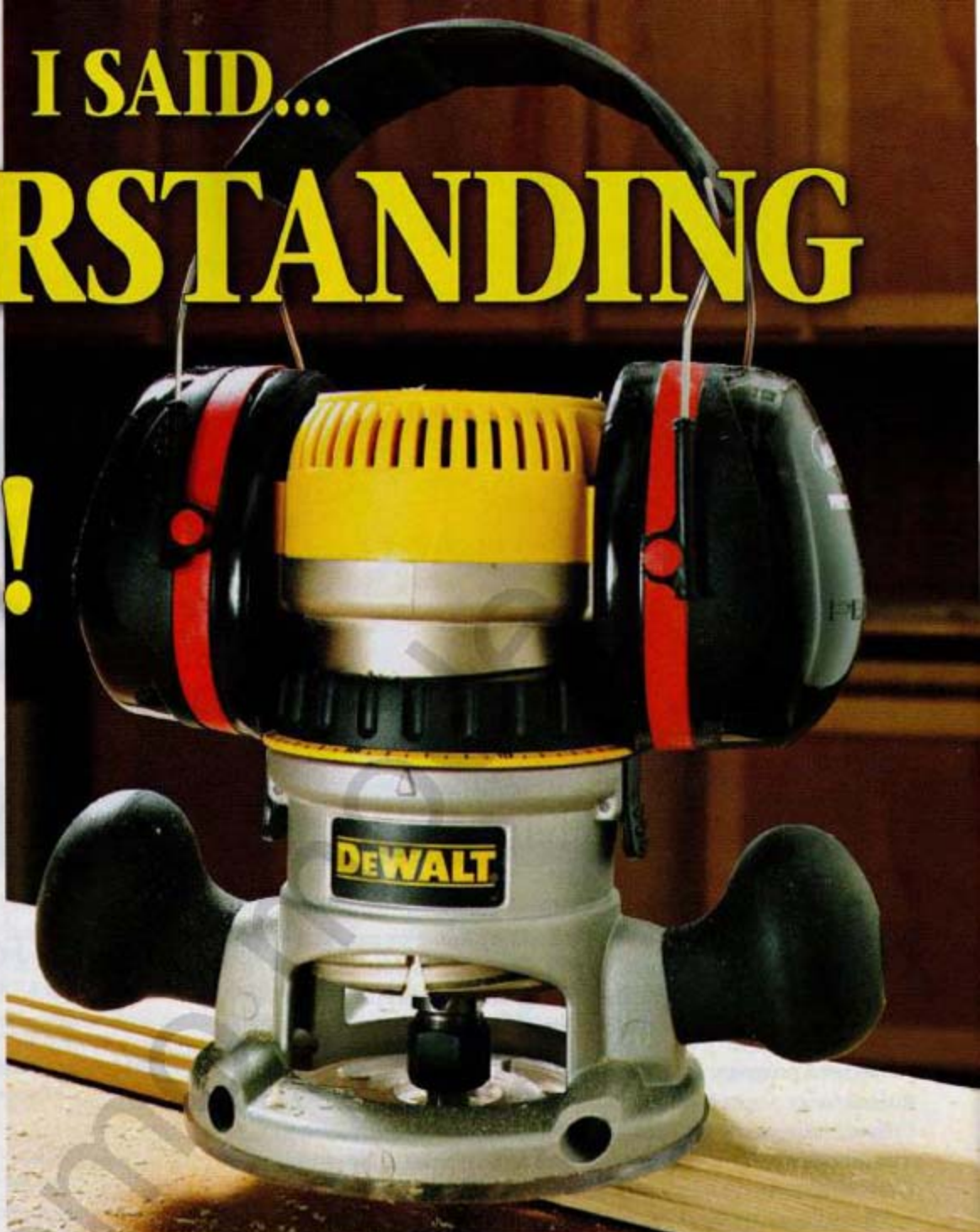

## Sound Level in Decibels

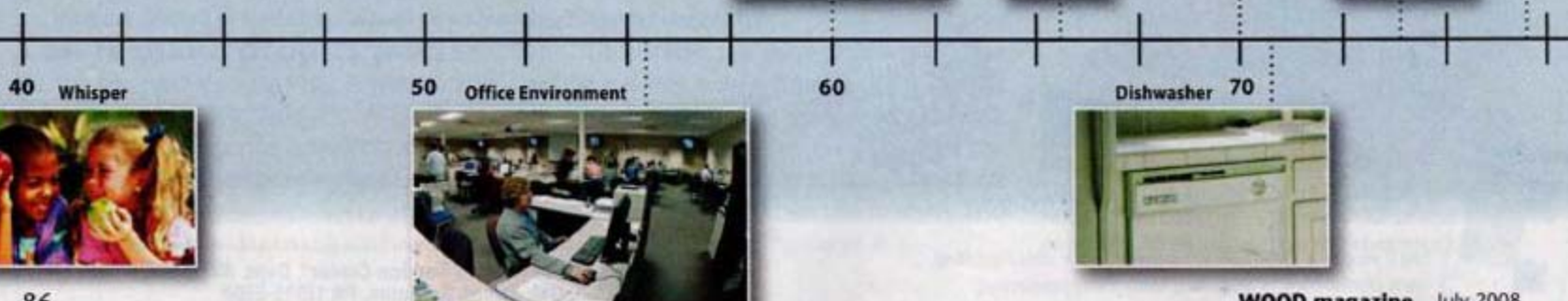



## CAN YOU HEAR ME NOW?



Audiologist Stephanie Fleckenstein delivers sound signals in different frequencies to Matt Seiler to test a pair of hearing muffs.

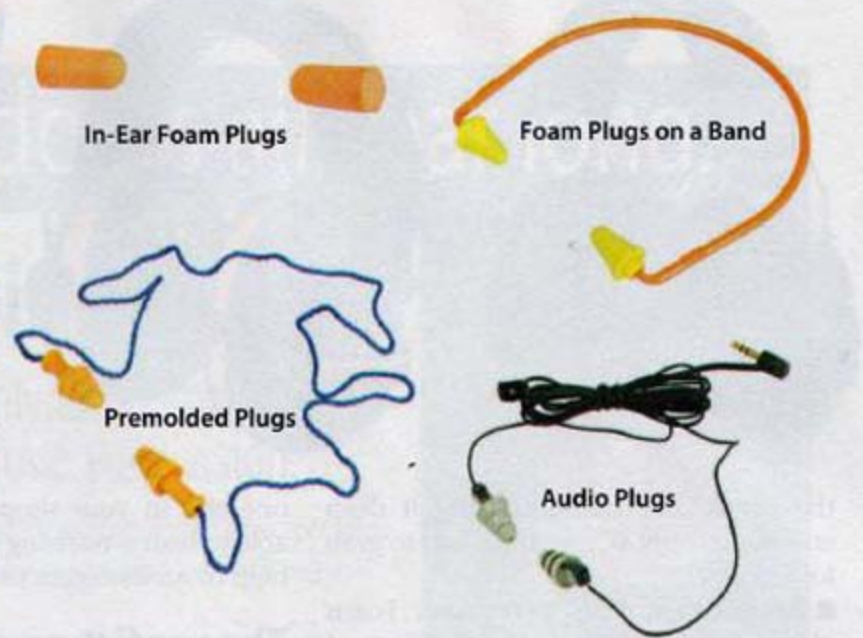

likely result in hearing loss. Just to be safe, wear protection anytime you fire up a machine.

### Which hearing protector should you wear?

Federal law requires all hearing protectors to include a noise-reduction rating (NRR) on their packaging. This figure is calculated by experts who measure the actual noise reduction as tested on hundreds of subjects, also factoring in each tester's hearing level and the testing conditions. But Stephenson cautions that because technicians calculate these ratings in laboratories where conditions

are ideal and free of other noise, the actual noise reduction you can expect to achieve in your shop equals about half that. That's due to such variables as:

- The user's ability and willingness to install the device correctly for maximum protection. (For a free PDF showing how to properly install in-ear foam plugs, go to [woodmagazine.com/plugs](http://woodmagazine.com/plugs).)
- Obstacles like eye glasses, safety glasses, hats, or beards that can prevent a tight seal of muffs around the ears.
- Each person's head and ears differ slightly in size and shape, so some protectors fit better than others and provide better protection.

So, use protection devices that reduce your shop's noise levels to below 85 dB. In other words, get the most NRR you can while still finding a protector that's comfortable and compatible with your eye protection. Then wear it!

In-ear plugs don't interfere with safety glasses, but do they work as well as muffs? To find out, we spent a day with Stephanie Fleckenstein, a certified audiologist at the University of Iowa's Department of Speech Pathology and Audiology. She put *WOOD*® magazine technical consultant Matt Seiler in a

sound-treated chamber, as shown *above left*, with a variety of hearing protectors, and measured the amount of sound attenuation at 10 frequencies (250–8,000 Hz). Here's what we found:

■ **Cheap is good.** Standard in-ear foam plugs—which cost pennies apiece—cut noise by 35 to 45 dB. The key here is proper insertion. Stephanie says to insert them as far as you can, but still be able to pull them out. She inserted the plugs into Matt's ears by rolling and compressing a plug, pulling his ear to better open

### Know how much protection you're getting

Protector Type	dB Attenuation
Standard in-ear foam plugs 1	35–45
Foam plugs on a rigid band 2	25–35
Passive muffs	15–35
Premolded ear plugs	20–35
Electronic muffs	20–35
Muffs coupled with foam plugs	35–55

NOTE: Results of *WOOD* magazine clinical testing of multiple protectors at the University of Iowa on one test subject. Actual reduction levels in your shop will be about half these amounts.

- 1 — With all but 1/4" inserted into ear canal  
2 — Inserted as deeply into ear canal as possible

### Noise level exposure limits before hearing damage occurs

Noise level, dB	Time (hours, minutes)
80	25:00
85	8:00
90	2:30
95	0:47
100	0:15
105	0:04
110	0:01

Source: National Institute for Occupational Safety and Health (NIOSH)

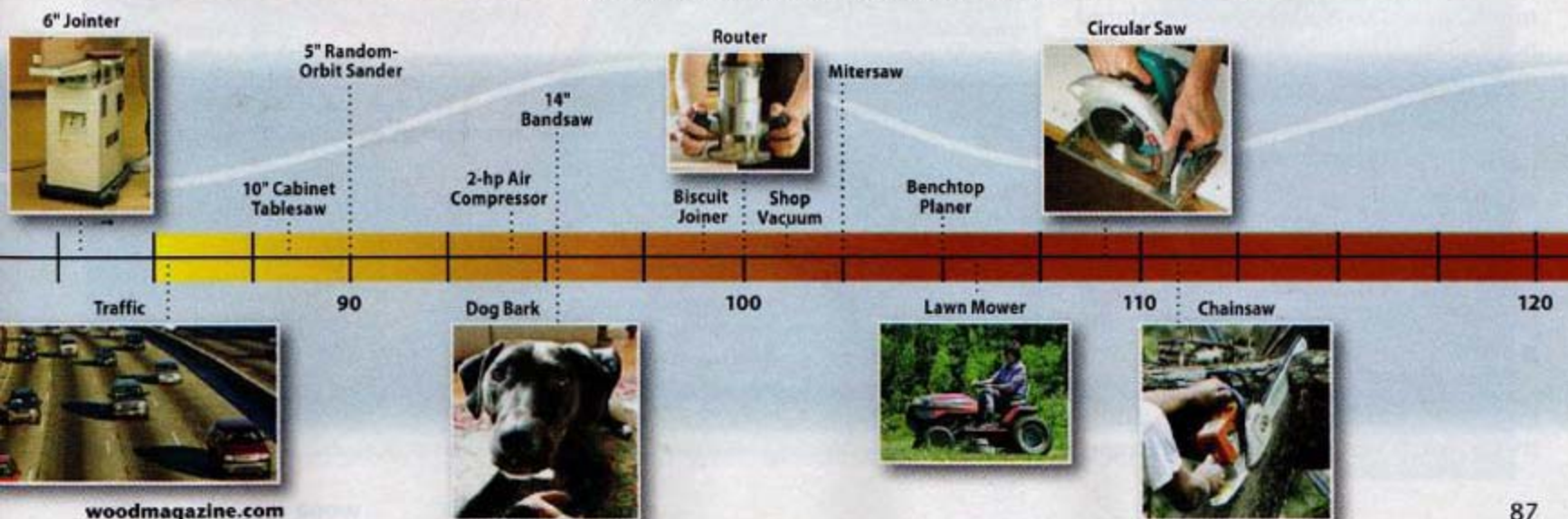



Passive Muffs



Noise-Canceling Muffs



Sound-Leveling Muffs



MP3 Earbuds



Small Headphones

the canal, and then inserting it deep enough so only 1/8" extended out to grab for removal.

■ **Bands are less effective.** Foam plugs on a rigid, plastic band delivered about 25 percent less noise reduction than individual, insertable plugs. Because these cone-shaped plugs primarily block the ear canal opening, we could not insert them as deeply.

■ **Cover those ears.** Muff-style, over-the-ear protectors proved easiest to use. Most of the passive muffs (ones with no electronic features to block noise) delivered protection at or above their NRR. (Read about four muffs we recommend on page 90.)

■ **Good, but not great.** Premolded silicone-type plugs did not protect as well as foam plugs or muffs, but they still delivered about 20- to 35-dB reduction in the lab. This includes in-ear audio plugs for MP3 players or radios, but not earbuds that only cover the ear.

■ **Double up for extra protection.** When you're making an especially loud noise—such as planing hard maple—increase your protection by wearing in-ear foam plugs *and* a muff-style protector. On average, this combination cuts noise better across the tested frequencies than either did by itself.

■ **Technology can be good or bad.** Electronic-style muffs yielded mixed results. The noise-canceling NoiseBuster muffs worked so well they even reduced noise above their 26 NRR in lower frequencies. Also, some muffs, such as the Peltor Alert, feature external microphones that elevate quieter sounds and reduce louder ones, keeping everything at a safe level. Shooting-style muffs designed to protect your hearing from loud impulse noises like gunshots, however, acted simply as passive muffs at consistent noise levels below 100 dB.

■ **Avoid total sound blackout.** You still need to hear feedback from your tools and machines as you're using them. And if you're working with some-

one else in your shop, you need to be able to hear a warning shout or a call for help in an emergency.

### The verdict on replacing shop noise with music

To entice users to wear hearing protectors, many manufacturers offer devices that reduce outside noise while allowing you to listen to a radio or MP3 player. But is it a good idea to replace one noise with another? Brian Fligor, director of the audiology program at Children's Hospital Boston and a leader in studying the effects of music on hearing, says, "The danger is in turning up that music volume to the point that it does as much damage as the very noise you're trying to avoid."

He says the best method for listening to music is to set the volume at a comfortable level when surrounding noise is low, and then leave it at that level. "Even

if the machine you're using gets louder than the music you're listening to, don't touch that dial," Fligor says. He warns that MP3 earbuds and small, foam-covered headphones that sit on the ear don't sufficiently—and safely—block loud noises. 🌿

Written by **Bob Hunter** with **Matt Seiler**  
Technical consultant: **Elliott Berger**,  
Senior Scientist, E-A-R/Aero Technologies  
Illustration: **Tim Cahill**

### How your hearing can go bye-bye

We all know, basically, how our ears work. But we wanted to know more about how, exactly, hearing damage occurs. Turns out that the cochlea in the inner ear contains microscopic, hairlike nerve receptors that transmit sound waves to the brain. Exposure to high noise levels causes those fragile hairs to bend or break. When this happens they no longer transmit signals, effectively and permanently breaking the chain at the frequency they're responsible for sending. That's why a person with hearing loss might not be able to hear normal conversation, but can still detect low- or high-pitched sounds. Damage also can be in the form of tinnitus, a ringing in the ears that competes with incoming sound waves. Tinnitus caused by high noise exposure generally cannot be reversed, but consult your doctor or hearing specialist for treatment options.

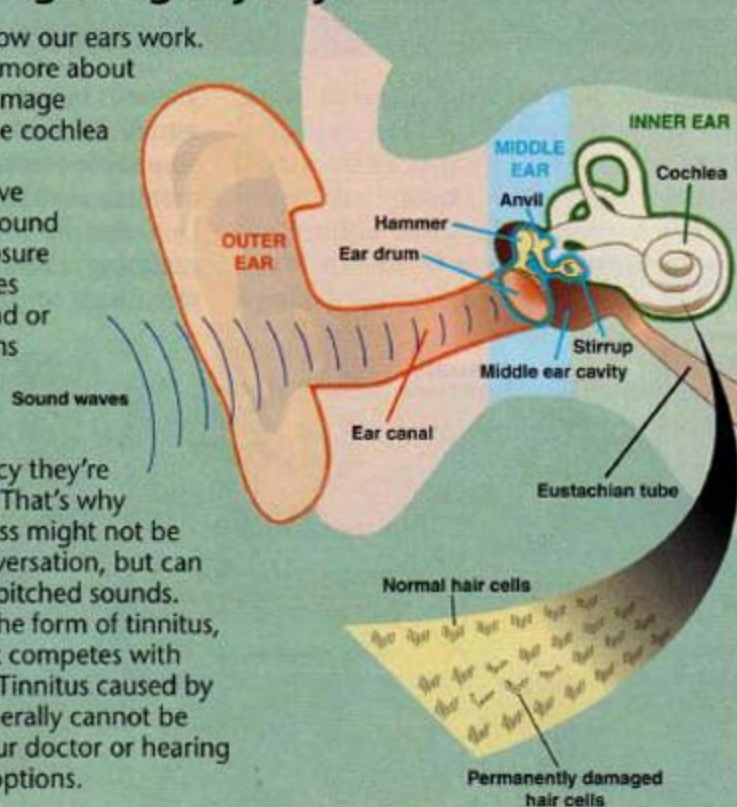

# Bring sunshine indoors all year long.

## BlueMax™ High Definition Lamp

The only lamp shown to improve your vision.

*Do you enjoy reading, writing or crossword puzzles? Do you carve, work on detailed projects, or spend long hours at a computer? Do you suffer from low vision, macular degeneration or winter depression?*



*"I took for granted the tiredness and eyestrain caused from working under cool white fluorescent lights. I had attributed this to getting older, but once I purchased my BlueMax lamp, it made all the difference in the world. My shop felt like I was working outside on a sunny day, increasing visibility of the pattern being cut. No more eyestrain or tired red eyes" - John, MD*

**No other lamp on the market has more research behind it!**

**Avid woodworkers** love BlueMax™ lamps! The only patented multifunctional lamp perfect for both task lighting and light therapy. Science has proven that using a full spectrum scotopically enhanced lamp will not only provide therapeutic benefits, but will take reading and detail work to the next level of optical brilliance.

**BlueMax™ patented** line of dimmable task and light therapy lamps promotes the brighter, healthier side of light. BlueMax™ uses a patented six phosphor blend, not only utilizing the brilliant qualities of sunlight at noon, but also enhancing the blue spectrum. This favors the scotopic qualities of the light, making it even clearer than regular full spectrum light.

**BlueMax™ has more features** and research behind it than any other lamp. BlueMax™ offers a selection of 70 watt dimmable, energy-efficient desk and floor lamps in a variety of finishes. Each lamp produces 4300 lumens (comparable to a 300 watt bulb), has a 96 CRI, while producing the 10,000 Lux necessary for light therapy. Our lamps do not produce any harmful UV Rays.

**Never buy another lamp!**

BlueMax™ Lighting engineers industrial grade floor and desk lamps. By using solid steel construction and modern electronics, we are able to provide unsurpassed quality for a lifetime.

No one can compare with BlueMax™ HD Technology.

High Definition Six Color Blend



	BlueMax™ 70w HD Lamp	Verlux® Happy Eyes	Ott-Lite® Pro
Watts	70	27	18
Kelvin Temp	5900K	6500K	5000K
Approximate Lumens	4,300	1450	975
Fully Dimmable	✓	N/A	N/A
Patented Electronic Ballast	✓	N/A	N/A
HD Six Color Bulb	✓	N/A	N/A
LifeTime Warranty	✓	N/A	N/A



**Satisfaction Guaranteed or your Money Back!**

Full Spectrum Solutions, Inc. ~ 712 East South Street Jackson, MI 49203 ~ (877) 258-3629



**Special Offer**



**FREE!**  
Replacement Bulb  
A \$29.50 Value

Sale Price

**\$189** -S&H

Regular Price ~~\$239.00~~

Matching desk models  
starting at \$159.00

Deluxe Brass & Nickel models  
also available.

Order now using  
**Promo Code WW08**  
to receive this special offer.



Call Toll Free

**877-258-3629**

or order online at  
[www.bluemaxlighting.com](http://www.bluemaxlighting.com)

# Wise Buys

Our Experts Test

# Muff-Style Hearing Protectors

## Why buy?

Power tools and machines make noise ranging from mildly annoying to downright harmful. (Learn more about the effects of shop noise on *page 86*.) Muff-style hearing protectors reduce the sound reaching your ears, effectively preventing hearing damage. You'll find muffs are easy to put on and take off, fit over safety glasses and hats, and they form tight seals around the ears. They can—and should—be used when using almost every power tool. For this article, we chose four different styles, from simple, passive muffs to high-tech noise-canceling models. The manufacturer's Noise-Reduction Rating (NRR) for each model is shown, and our testing with a professional audiologist confirmed the accuracy of those figures.

### PELTOR OPTIME 105, #H10A, \$18

NRR 29 dB

#### Editor test-drive:

One of the noisiest spots in my basement workshop is the area near a screaming shop vacuum connected to the bandsaw. Without hearing protection, my ears start ringing before I can make the first cut! The Peltor Optime muffs deaden that noise so effectively, it's barely detectable. As if that were not great by itself, these muffs also fit so nicely, I wore them for hours at a time without discomfort. The thick, wide cushioning creates a tight seal without crushing safety glasses into my temples. And the adjustable wire bands allow me to

extend the cups farther apart and bend them slightly outward to adjust the pressure for a perfect fit.

—Tested by Bob Wilson, Techniques Editor

To learn more: 800-665-2942; peltor.com



### AOSAFETY DIGITAL WORKTUNES, #90541, \$60

NRR 22 dB

#### Editor test-drive:

I've used WorkTunes radio muffs in the past, and in AOSafety's new model, a digital tuner with five AM and FM presets has replaced the old analog dial, making it much easier now to find a particular radio station. Now I can flip between AM and FM bands without losing my station, and I get great sound quality and reception. Another improvement is an included cord for hooking up an MP3 player. And to keep me from cranking up the tunes too loudly, the volume control tops out at 85 dB, the level where hearing damage begins to occur.

—Tested by Jeff Mertz, Design Editor

To learn more: 800-327-3431; aosafety.com/diy



### PELTOR ALERT, #M2RX7A, \$120

NRR 25 dB

#### Editor test-drive:

The comfortable Peltor Alert muffs "replace" my hearing so well I never take them off in my shop. They protect my ears against loud noises but allow me to still hear what I need to, such as feedback from tools. Here's how they work: External microphones on each cup pick up sounds from around the shop, and then reduce the high-decibel sounds or amplify softer sounds—keeping every sound at

a safe level. So I can hear the swoosh of a block plane as easily as the muted whine of a router. The self-leveling circuitry responds quickly, reducing the POP! of a brad nailer to the point where I only hear a fraction of that usually loud impulse noise. This unit also has a built-in AM/FM radio with a separate volume control.

—Tested by Dave Campbell, Deputy Editor

To learn more: 800-665-2942; peltor.com



### NOISEBUSTER, #PA4000, \$149

NRR 26 dB

#### Editor test-drive:

Even if the Noisebuster muffs did not have electronic capabilities, they'd still be exceptional, comfortable passive muffs. In addition to being a pro woodworker, I'm also a sound technician and own a recording studio, so I know and love sound gadgets. Noisebuster uses a noise-canceling technology that samples the sounds around you with a built-in microphone, and then replicates sound waves exactly

opposite of the harmful ones. This effectively reduces noise—especially hard-to-tame low frequencies—to below the danger level of 85 dB before it reaches your ears. It proves so effective at blocking dangerous noise levels that I was blown away. Although there's no built-in radio, the Noisebuster does have an input jack for an MP3 player.

—Tested by Matt Seiler, WOOD Online Forum Host

To learn more: 877-226-1944; noisebuster.net



# FREE SHIPPING\*\*

You'd pay hundreds more if you purchased these router bits separately!

A dream buy for wood workers... 35 high-quality router bits for just \$1.14 each! This incredible set has a huge assortment of bits that let you V-groove, flush trim, chamfer, dovetail and much more with professional results every time. Bits have 1/4" shank and are solid carbide or carbide tipped for years of dependable use and clean cuts with a working error of less than 0.2 mm. Bits come in a wooden storage case with labels to keep them clean and organized.

**EXTREMELY**  
INTERESTING

BIGGER & BETTER  
**35**  
PIECE SET

Compare At: \$310.09  
**YOUR PRICE \$39.99**  
Item No. UB41-56652 Ship \$7.50



Ditch the cords, gas & hassles...trim it the easy way!



**18V**

Up to 40 minutes run time per charge!

**POLLUTION FREE**

**WHISPER QUIET**



From finishing lawns to leveling tall field grass, this cordless rechargeable 9" string trimmer makes it quick, easy & convenient! Don't put up with tangled extension cords or the weight & mess of a gas powered model. Get this rechargeable string trimmer! It has a wide 9" cutting path & an 8000 rpm motor to power through tall grass & weeds, an ergonomic handle & a reliable automatic string dispenser. Comes with 18V Ni-Cad battery pack with approx. 40 minutes run time per charge, 10' of line, adjustable length handle & charger adapter. Additional batteries and charger/adapters available. Ask your operator for details.

Compare At: \$117.80  
**YOUR PRICE \$39.99**  
No. UB41-57337 Ship \$9.95

**New and improved for 2008! This 8' market umbrella has an integrated pulley system for fast, effortless opening!**

**Green**

**NEW & IMPROVED FOR 2008**

Relax in the cool shade & protect your loved ones from the harmful effects of ultraviolet rays! It opens to a full 8' in diameter to provide a huge oasis of cool shade & has six wood ribs for extreme durability in wind. Also has pulley system that lets you open it by simply pulling down on a cord, rugged polyester fabric with air flow vents, 1-3/8" diameter wood frame & 7' height. Choose green or natural color. Fits in most patio tables & bases. Sturdy metal bases also available, ask operator for details.

Compare At: \$149.99  
**WAS: \$49.99**  
**LOWEST PRICE EVER!**  
**\$29.99\***/each  
Green Item No. UB41-64774  
Natural Item No. UB41-64775  
Ship \$18.95

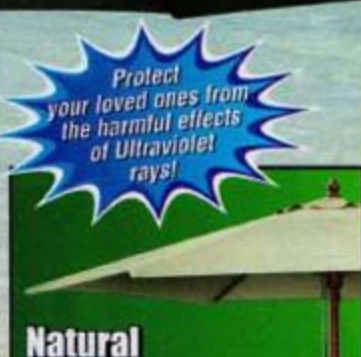

Protect your loved ones from the harmful effects of Ultraviolet rays!

**Natural**

When you really want the job to look like the pros did it, call in the Wagner paint crew!

The Paint Crew paint sprayer system delivers professional results without paying the price! It features on-demand piston pump technology that maintains pressure as needed; professional-grade forged aluminum spray gun with in-line filter; reversible spray tip that provides a superior finish and clears clogs with just a twist; and centrally located controls that simplify operation. Also has 25' high pressure hose for extended multi-story reach and two-gallon paint hopper that minimizes trips up and down the ladder. 90-day ltd. warr.

Orig. MSR: \$219.99  
**ORIGINALLY: \$199.99**  
Item No. UB41-20573  
Factory serviced  
**NEW LOW PRICE!**  
**\$99.99**  
Ship \$18.95



**CONTRACTOR'S GRADE**

**3/8 HORSEPOWER**  
**Paints One Gallon Every 5 Minutes!**  
25' high pressure hose

**NOTICE:** Through special arrangements with Wagner we were able to secure an extremely limited number of these professional quality paint sprayers. Order early to avoid disappointment.

Bore clean, deep holes in soft or hard wood with virtually no effort!

For running electrical wires through floor joists, assembling 2x4 wood playsets for the kids and other tasks, these auger bits make the job a snap! Put some excitement into your next "boring" job with this tradesman's quality 16-pc. set. Each bit is forged from #45 carbon steel and has a heat-treated to HRC47 hardness tip, flutes ground behind the lands to pull chips up for fast, clean cutting and a polished finish. Includes 3/8", 1/2", 5/8", 3/4", 7/8" and 1" bits in both 4-3/4" and 8" lengths and 1/2", 5/8" and 3/4" bits in 16" length. Bits come in protective case.

**16 PIECE SET**

**SPECIAL BUY LTD. QUANTITY**

Compare At: \$154.99  
**YOUR PRICE \$29.99**  
Item No. UB41-56447 Ship \$7.50



**COMMERCIAL QUALITY**  
FOR INSTITUTIONAL & INDUSTRIAL USE

Titanium nitride coated forstner bits last longer than any bit you've ever owned.

Compare At: \$110.00  
**WAS: \$39.99**  
**NOW ONLY \$24.99**  
No. UB41-56443 Ship \$7.95

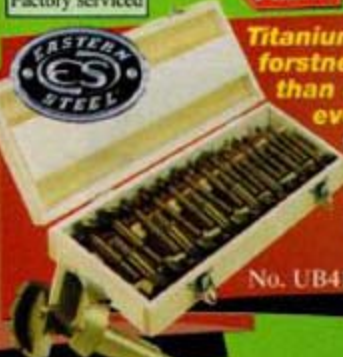

Talk to others at distances of up to 16 miles with these Midland 22-channel GMRS radios!

MSR: \$39.99  
**ONLY \$29.98**/pair  
Water Resistant  
22 CHANNEL  
No. UB41-86000 Ship \$7.50



Strap it on your wrist and help disarm the silent killer!

Compare At: \$109.99  
**ONLY \$19.99**  
Ship \$7.50



**St. John's HOSPITAL QUALITY**

**1 TOUCH**  
Auto-Inflation AND Auto Deflation



**HEARTLAND AMERICA**

Call Toll-Free, 24 hours a day, 7 days a week

National Headquarters:  
8085 Century Blvd.  
Chaska, MN 55318

The Best Values Direct to you from the Heartland!  
Some limitations may apply. Ask your operator for details.  
Overweight items have dramatically reduced shipping.

**1-800-229-2901**

**FREE SHIPPING\*\***

Receive **FREE** Shipping On Your 1st Online Order!

WWW. Enter Code: UB41UB41  
**HEARTLANDAMERICA.com**



## A-Cut-Above Knife Handles

Buy the blades and add your own wood for a set worthy of the finest place settings.

**H**ere's a project you'll enjoy almost every day. And the parts are small enough to use up some of that precious scrap from your stash. Select durable, tight-grained hardwood or synthetic materials that don't splinter or split when you shape them. (We used acrylic-impregnated Dymondwood—see Sources, opposite page.)

For the blades we chose a set of 10 knives and one carving fork, but the technique works the same for any knife. Our set features four large utensils (two carving knives, a boning blade, and the two-pronged fork) with handles  $\frac{7}{8}$ " or more in width and thickness, and seven small ones (a carving knife, two paring knives, and four steak knives) with handles less than  $\frac{3}{4}$ " in width and thickness.

### Cut the blanks to size

**1** Begin by machining your stock to thickness:  $\frac{3}{8}$ " for the large knives and  $\frac{1}{4}$ " for the small ones.

**2** Cut the blanks (known as scales)  $\frac{1}{8}$ " longer than the blade tang to which they will be attached.

**3** Secure two scales together, with one end flush, using double-faced tape. Place the tang of the blade onto one face of the scales. Scribe the shape of the tang [Photo A] and mark the rivet holes for

drilling. Mark the center of each hole with an awl or punch.

### Bore the rivet holes

**1** Drill  $\frac{1}{16}$ " pilot holes through each center mark. Back up each hole to prevent tear-out.





**2** Using the  $\frac{3}{16}$ " pilot hole as a guide, center a brad-point bit and drill counterbores [Photo B] on each face for the rivet heads. Use a  $\frac{3}{16}$ " bit for the large knives and  $\frac{1}{16}$ " for the small ones. Set the depth so the rivet head will be flush with the wood face.

**3** Enlarge the pilot holes with a standard-point twist bit. Use an  $\frac{11}{64}$ " bit for the large rivets, and a  $\frac{1}{8}$ " bit for the small ones. Set a depth stop to drill only through one scale; then flip it over and drill the opposite scale.

### Begin shaping the handles

**1** You will need to shape the blade end of the scales before assembly to avoid damaging the blade. Measure and mark a perpendicular line  $\frac{5}{16}$ " from the end on the large knives and  $\frac{3}{16}$ " on the small ones. Sand a radius [Photo C] that stops at the line.

**2** Using a bandsaw or scrollsaw, cut the scales to shape, staying about  $\frac{1}{16}$ " outside the scribed lines [Photo D].

**3** Polish the blade end of the scales with white rouge buffing compound and a cloth wheel [Photo E].

**4** Separate the scales and remove the double-faced tape. Sand the inside face of each scale to 220 grit until it is smooth and flat. Wrap the blade with two layers of masking tape [Photo F] to prevent an accidental injury. Sand the blade tang with 220-grit sandpaper as well to remove burrs. Wipe it clean.

### Assemble the handles

**1** Mix and apply epoxy to the tang and inside faces of the scales.

**2** Insert the female rivets into the holes of one scale, fit the blade tang onto the rivets, and add the other scale. Align the finished ends.

**3** Insert the male rivets into the holes, beginning with the one nearest the blade, then the rivet at the opposite end, and finishing with the middle one. Use a small hammer to gently tap them together [Photo G], keeping the scales lined up at the blade end.

**4** Press the handle tightly in a bench vise; allow the epoxy to cure overnight. Don't overtighten; apply just enough force so the epoxy begins to squeeze out.

### Finish shaping the handles

**1** After the epoxy has cured, use a rasp and file to remove the corners [Photo H] and create a comfortable shape. (We made about a  $\frac{3}{8}$ " round-over on the large knives and a  $\frac{1}{4}$ " one on the small ones.) Stop when the wood is flush with the tang.

**2** Sand the handle and tang, beginning with 80-grit sandpaper and working up through 600 grit.

**3** Buff Dymondwood handles with a cloth wheel and white rouge buffing compound [Photo I]. For hardwoods, apply an oil or polyurethane finish to the handle. 🌱



### EXPLODED VIEW

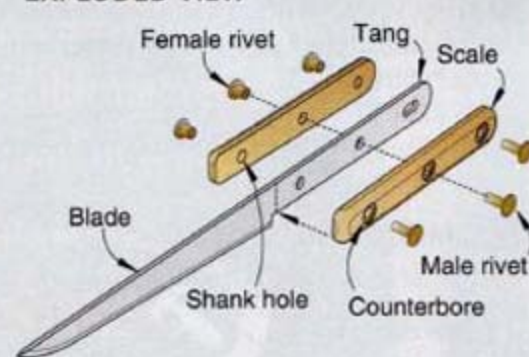

### Sources

**Blades and utensils:** Kit includes blades, fork, Dymondwood, and rivets, part #SS801, \$70, Jantz Supply, 800-351-8900, knifemaking.com.

**Epoxy:** Devcon 2-ton epoxy, 9 oz., \$10.45, Jantz Supply.  
**Other blade and utensil sources:** Texas Knifemaker's Supply, 888-461-8632, texasknife.com; Knife and Gun Finishing Supplies, 800-972-1192, knifeandgun.com; Alpha Knife Supply, 425-868-5880, alphaknifesupply.com.

Written by **Bob Hunter** with **Kevin Boyle**

# Scrapwood Project

## In-Drawer Knife Holder

Put your shop leftovers to work in the kitchen.

**N**ot only can you craft this knife rack in a few hours, but you also can customize it to fit your kitchen drawer as well as your cutlery collection.

### Start with the template

**1** Make multiple copies of the full-size knife-holder patterns from the *WOOD Patterns*® insert on page 53—one right and left pattern for every knife your rack will hold and one copy for the template jig.

**2** On a  $4\frac{1}{4} \times 15$ " piece of MDF, adhere the right knife-holder pattern with spray adhesive, carefully lining up the top and handle end with adjacent edges of the MDF [Drawing 1].

**3** Rough-cut the shape of the pattern on the bandsaw, staying just outside the pattern line. Finish shaping the template on a spindle sander or with a drill-press sanding drum. Then build the template jig [Drawing 1].

### Fashion the holders

**1** Cut  $1\frac{1}{2} \times 12\frac{3}{4}$ " knife-holder blanks from  $\frac{1}{2}$ " stock and carefully adhere the left and right knife-holder patterns to the blanks.

**2** With a  $\frac{3}{8}$ " brad-point bit in your drill press, drill holes  $\frac{1}{4}$ " deep where

indicated on the patterns. For accuracy and repeatability, set your drill press's fence and a stopblock when drilling the first hole for each location before moving on to the remaining corresponding holes.

**3** Bandsaw the knife-holder sides to shape, staying just outside the pattern line. Clamp a rough-cut side in the template jig and rout the part to final shape using a flush-trim bit in your router table, as shown at right.

**4** Remove the patterns from the knife-holder sides, sand the faces and edges to 220 grit, and round the edges at your router table using a  $\frac{1}{8}$ " round-over bit, where shown on Drawing 2.

### Assemble the rack

**1** Cut two pieces of  $\frac{3}{8}$ " dowel  $1\frac{1}{16}$ " long for each set of holders. Glue them into the holes in the holder sides and assemble each holder [Drawing 2].



After bandsawing the knife-holder side to rough shape, clamp it into the template jig and flush-trim the piece to final shape at your router table.

**2** From  $\frac{1}{4}$ " plywood, cut a backer board  $12\frac{3}{4}$ " long. Multiply the number of holders you made by  $1\frac{1}{16}$ " to determine the total width needed for the backer board.

**3** Glue the knife-holders to the backer board [Drawing 2]. When the glue dries, spray on three coats of aerosol polyurethane, sanding to 220-grit between coats. 🌳

Illustrations: Roxanne LeMoine; Lorna Johnson

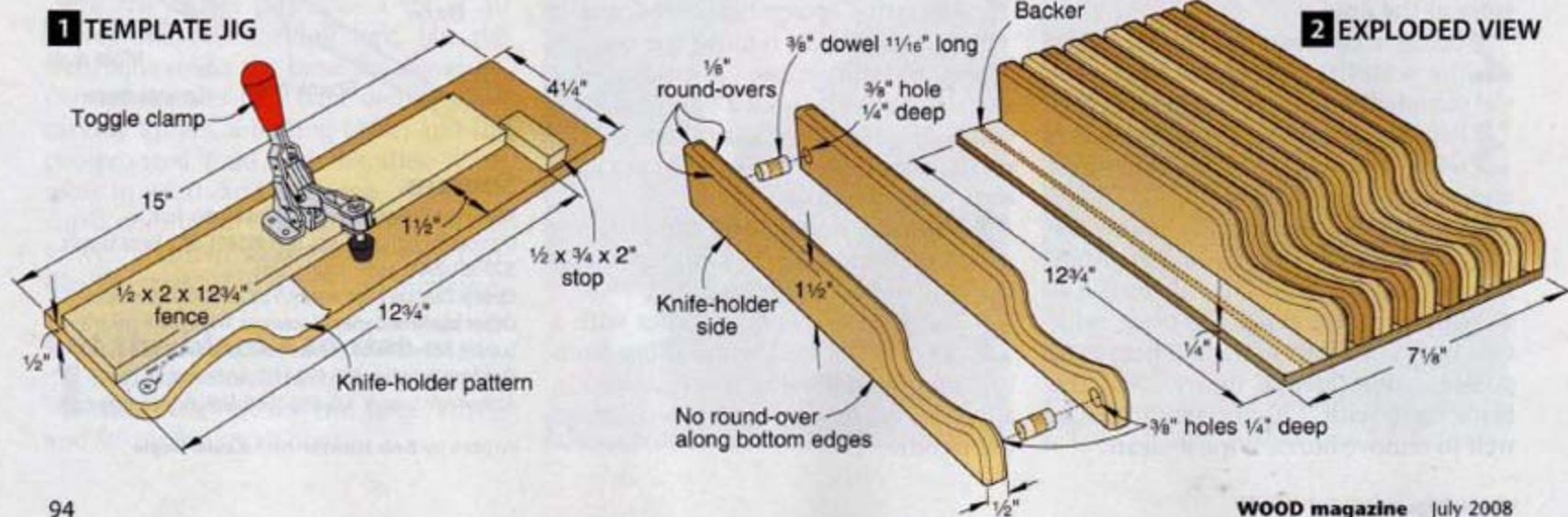



## Air Locker P630

23 Gauge Headless Micro Pin Nailer

- Extra Driver
- O' Ring Kit & Swivel Adapter
- Comes with Oil, in a Rugged Aluminum Case

Pins 1/2", 5/8", 3/4", 1", 1-3/16"

2000/box \$3.99/box

Uses 23Ga Senco & Porter Cable Micro Pin Nails

Maintenance Kit also available PK330AM

**\$59.99**

## OASIS Miter Saw Stands

- BST07** \$119.99  
Lightweight aluminum 5-1/2 ft beam extends to support up to 16 ft of material
- BST08** \$99.99  
Lightweight aluminum 4 ft beam extends to support up to 10 ft of material

## OASIS 1735A Dust Collector 1HP Mobile Tabletop

- Great addition for any woodworking shop
- This unit has a 4" intake
- Air suction capacity of approx. 500 CFM
- 2 cu-ft bag volume capacity
- 30 Micron bag

**\$109.99**

## Panasonic EY6405FQKW 12 Volt 3/8" 2 Ah NiCd Cordless Drill/Driver Kit

- Length: 8-3/16"
- Power: 293 in.-lbs. of torque
- Battery: Standard capacity 2.0 Ah Ni-Cd
- Chuck: 3/8" Heavy-duty keyless
- Charging System: 30 mins (using EY0250B charger)

**\$99.99**

All Panasonic products includes: 2 Batteries, Charger and Heavy Duty Case

## Panasonic EY6432NQKW 15.6-Volt 1/2" Cordless Drill/Driver Kit

- Torque: 390 in.-lbs.
- Speeds: Low 65-450 rpm High 200-1450 rpm
- Chuck: 1/2" heavy-duty keyless
- Clutch: 9 - 61 in.-lbs. 18 stages

**\$149.99**

New product available for \$179.99

## Panasonic EY6506NQKW 12-Volt NiMH Cordless Impact Driver

- Length: 6-1/8"
- Power: 957 in.-lbs. of torque
- Battery: High capacity 3.0Ah Ni-MH
- Speed: 0-2500 rpm variable

**\$169.99**

New product available for \$219.99

## Adjustable Rolling Stand



Model #: T1732

**\$109.99**

## BEST PRICES

Visit our website for latest merchandise



## Roller Stand



Model #: T1733

**\$79.99**

[www.Toolmarts.com](http://www.Toolmarts.com)

1-800-735-8665

Circle No. 1770

# CARVEWRIGHT™ WOODWORKING SYSTEM

## Computer Controlled Woodcarving Machine

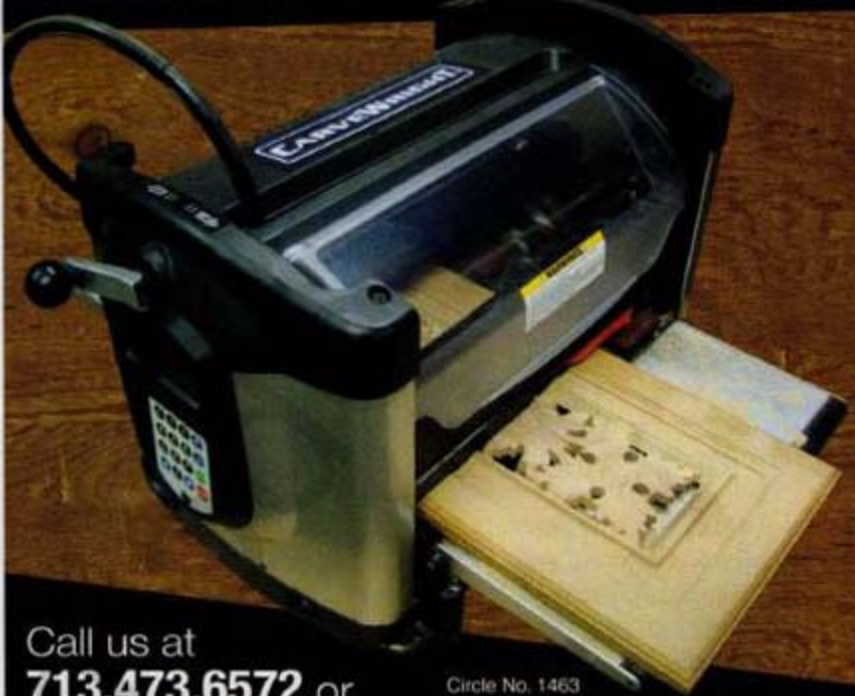

Call us at **713.473.6572** or  
Visit us at [www.carvewright.com/wood](http://www.carvewright.com/wood)

Circle No. 1463

**DEFINITION:** A computer-controlled, multi-function shop tool for routing, drilling, carving, machining, sawing, grooving, turning, joint making, engraving, sign making and intricate cutting of wood, plastic and aluminum...

...We call it **Buddy**



The new **ShopBot PR3alpha BT32** is here. Call or visit us online to learn more about the latest high-performance CNC systems from **ShopBot**.



[www.shopbottools.com](http://www.shopbottools.com) 888-680-4466

What would you like to make today?

Circle No. 1714

**NEW!**

Osborne Wood Products, Inc. introduces a *new* Island Leg featuring intricate, *hand carved* acanthus leaves.



[www.osbornewood.com](http://www.osbornewood.com)

Order Line: 800.849.8876  
For a Catalog: 800.746.3233  
info@osbornewood.com

4618 GA Highway 123 N  
Toccoa GA 30577

# 1741



Circle No. 1851

# Ask WOOD

Answers to your questions from letters, e-mails, and WOOD Online®

## HAVE A QUESTION?

For an answer to your woodworking question, write to **ASK WOOD**, 1716 Locust St., LS-221, Des Moines, IA 50309-3023 or e-mail us at [askwood@woodmagazine.com](mailto:askwood@woodmagazine.com). For immediate feedback from your fellow woodworkers, post your questions on one of our woodworking forums at [woodmagazine.com/forums](http://woodmagazine.com/forums).

## Rescue mission: Walnut lumber from logs

**Q:** A friend bulldozed down some large black walnut trees, and I talked him into letting me rescue them from the burn pile. How do I turn these trees into useful lumber?

—Dave Emmerling, Douglas, Texas

**A:** For large trees, it's time to call in the experts, Dave. Wood-mizer (800-553-0182, [woodmizer.com](http://woodmizer.com)) or Timberking (800-942-4406, [timberking.com](http://timberking.com)) can provide you with names of sawyers in your area who operate portable sawmills.

Make sure the sawyer cuts the timber extra thick to allow for wood shrinkage and planing—about 1" thick slabs for  $\frac{3}{4}$ " finished stock. Also, consider asking for lumber in larger thicknesses, such as 8/4, which can be difficult to find and expensive. You can always resaw or plane the lumber thinner.

As soon as possible after cutting, seal the ends with an end grain sealer, as shown at *right*, or several coats of paint. Green wood begins to shrink immediately due to moisture loss. The end grain is especially susceptible and could split if left untreated. Then sticker and



stack the wood to dry. You can use a moisture meter to check the wood's progress, but a good rule of thumb to follow is one year of drying time for every 1" of wood thickness.

Because your friend knocked down these trees with a bulldozer, you might

be able to get at the tangle of roots at the base of the tree. It's hard work, but worth the effort as this is often where the most highly-figured wood, such as burl, hides. Dig it out as best as you can and blast the wood clean with a power washer before cutting.

## Will frozen moisture in wood have a chilling effect on joinery?

**Q:** With the temperature dropping below freezing in my unheated shop, I'm worried about wood movement. Does frozen moisture in hardwood or sheet goods make the wood expand? Will shrinkage make joints and reveals sloppy when I bring my project inside?

—Gary Kosin, Chisago City, Minn.

**A:** Gary, keep in mind the old adage "It's not the heat, but the humidity" when considering wood movement. Most properly dried lumber and sheet goods won't have enough moisture content for their dimensions to be affected by freezing temperatures.

In fact, the expansion will most likely occur when you bring your project inside rather than when it is out in the cold of the shop. Winter weather

often brings drastic drops in humidity. A completed project that is brought from the dry winter weather into the warm house where you steam vegetables, take hot showers, and exhale moist air, will experience expansion—primarily across the grain—as it takes on the moisture of its new, warm surroundings.

However, there are a few ways to design your project to account for the change in humidity it will experience: Install drawer dividers using sliding dovetail joints that won't restrict movement across the grain of the case. Attach tabletops with sliding clips rather than fixing them in place. Allow extra room for panels to expand widthwise in their frames. Likewise, allow extra clearance for the width of drawer faces.



Finally, despite its dryness, winter weather slows drying times, and freezing temperatures bring drying to a halt. Acclimate your project in a warm place for a few days before proceeding with glue-up, finishing, and drying.

*continued on page 98*

# New Dovetail Jigs by Leigh! 12" 18" or 24"

FROM  
**\$219**

Dealers may sell for less



OPTIONAL  
VRS VACUUM &  
ROUTER SUPPORT

**25**  
YEARS  
of Innovation  
and Excellence

**Leigh Super Jigs** rout through, half-blind, sliding, single pass half-blind dovetails and box joints. Includes bits, guidebush, DVD, etc.

[leighjigs.com](http://leighjigs.com) 800-663-8932

**LEIGH**  
Leigh Router Joinery Jigs

# The Affordable Planer-Moulder

*The Baker*  
**M-412**



CONTACT  
BAKER PRODUCTS  
TODAY FOR FREE  
INFORMATION

Get the professional results you want with the Baker M-412 4-side Planer-Moulder.

E-mail: [info@baker-online.com](mailto:info@baker-online.com)

Phone: (573) 663-7711

(800) 548-6914

[www.logtolumber.com](http://www.logtolumber.com)

**BAKER**  
Products

*Your Log To Lumber Leader*

Circle No. 1428

# Refinish Your Future.

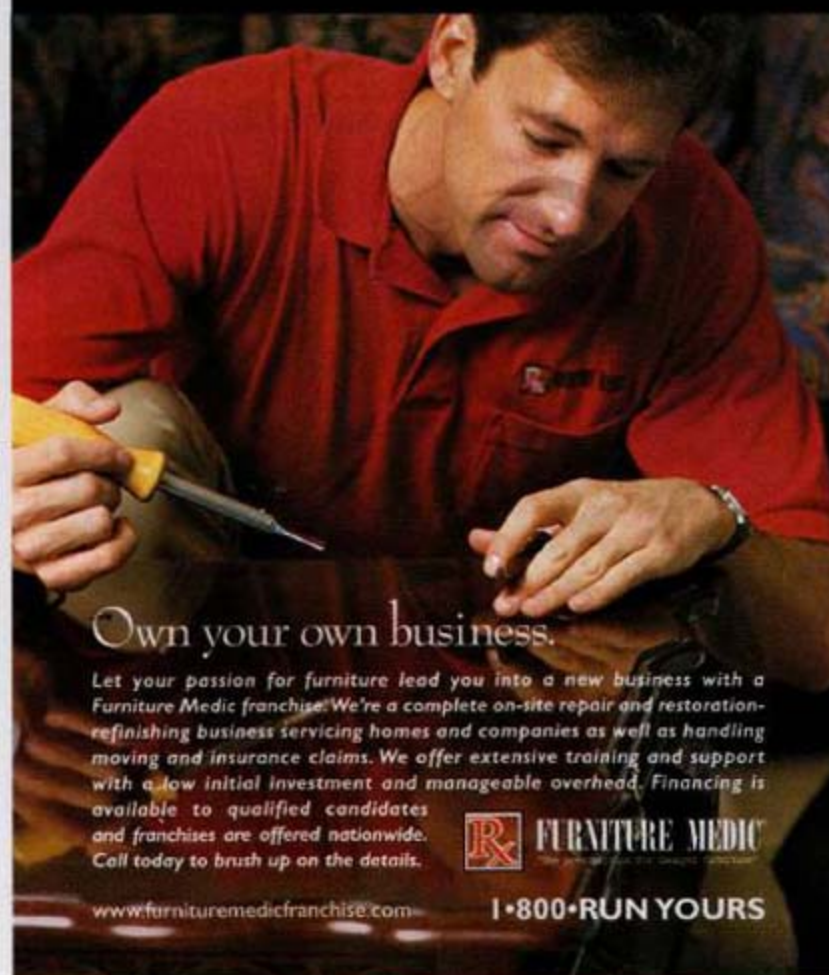

Own your own business.

Let your passion for furniture lead you into a new business with a Furniture Medic franchise. We're a complete on-site repair and restoration-refinishing business servicing homes and companies as well as handling moving and insurance claims. We offer extensive training and support with a low initial investment and manageable overhead. Financing is available to qualified candidates and franchises are offered nationwide. Call today to brush up on the details.

**FURNITURE MEDIC**  
The original and the largest franchise

[www.furnituremedicfranchise.com](http://www.furnituremedicfranchise.com)

1-800-RUN YOURS

Circle No. 895

## Your Vision. Your Creativity. Your Business excels with an **Epilog Laser System.**

### The Epilog Difference

From laser engraving and cutting basic logos and text to the most intricate and sophisticated designs, Epilog laser engraving systems allow you to customize all of your wood products quickly and easily.

### Get Creative with an Epilog Laser

From engraving and cutting custom plaques to wood puzzles to pens, our laser systems provide a wide variety of additional capabilities and service to your business.



Systems starting at \$9,995!

20 Years  
in 08

Contact us NOW to receive your free informational kit which includes:

- Epilog's Full Brochure
- A CD Demo featuring our machines in action
- Engraved and cut samples
- A laser engraving wood workers guide.

**E**  
EPILOG  
LASER

Epilog Laser • 1.888.437.4564 • [sales@epiloglaser.com](mailto:sales@epiloglaser.com)

[www.epiloglaser.com/bhg.htm](http://www.epiloglaser.com/bhg.htm)

Circle No. 1515

## Tape cures a sticky glue-up

**Q:** I have 16 pieces of  $\frac{3}{4} \times 2\frac{1}{2} \times 20$ " stock with a 22.5° bevel on one edge. I want to assemble them in pairs to form the legs for two octagonal tables. I need to glue the two beveled edges together, but have a hard time applying firm pressure on the joint to force the slightly wavy outer edges of the bevels to match.

—Tom Dwyer Jr., Niles, Ohio

**A:** A roll of reinforced shipping tape will solve your angled glue-up problems, Tom, but your likelihood for success will increase if you use stock that's machined and beveled as straight as possible to do away with those "slightly wavy outer edges."

Butt the points of the bevels together along their entire length. To prevent one of the pieces from popping up and over the other piece, attach clamps (A) over the joint with light pressure. If your clamp's pads don't span the combined bevels, add scraps between the clamp pads and the workpieces.

Then attach clamps (B) using just enough pressure to bring the edges together along their full lengths.

Now, stretch pieces of reinforced shipping tape across both faces, as shown *below left*. Space them about 4" apart, and leave 8" extra tape beyond the edge of the wood. Remove the

clamps and turn the assembly upside down. Apply glue to the bevel, and pull the beveled edges tightly together in a 45° angle using the extra 8" of tape as a clamp, as shown *below right*. After the glue dries overnight, remove the tape carefully to avoid pulling loose any wood fibers. 🌲

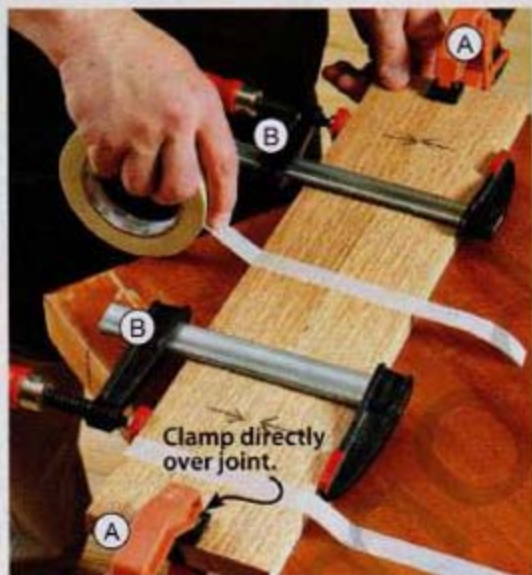

Osborne Wood Products, Inc. is now offering a new group of elegant appliques.



[www.osbornewood.com](http://www.osbornewood.com)

Order Line: 800.849.8876  
For a Catalog: 800.746.3233  
[info@osbornewood.com](mailto:info@osbornewood.com)  
4618 GA Highway 123 N  
Toccoa GA 30577



Make safer, cleaner cuts with quality accessories

**Feather-Loc** prevents chatter, gouging and dangerous kickback. Durable polymer feather tips are rounded so they won't mar your workpiece. 10-005



**Push-Loc** is the ultimate push stick for safety and convenience. Offset handle protects your hand, improves visibility and allows for horizontal use. Docking station mounts right to your tool. 10-025



**NEW Free Catalog!**

Bench Dog products are available at fine woodworking stores across the country! For Dealer Locations and a **FREE Catalog** visit [benchdog.com](http://benchdog.com)

Available on  
Newsstands NOW!

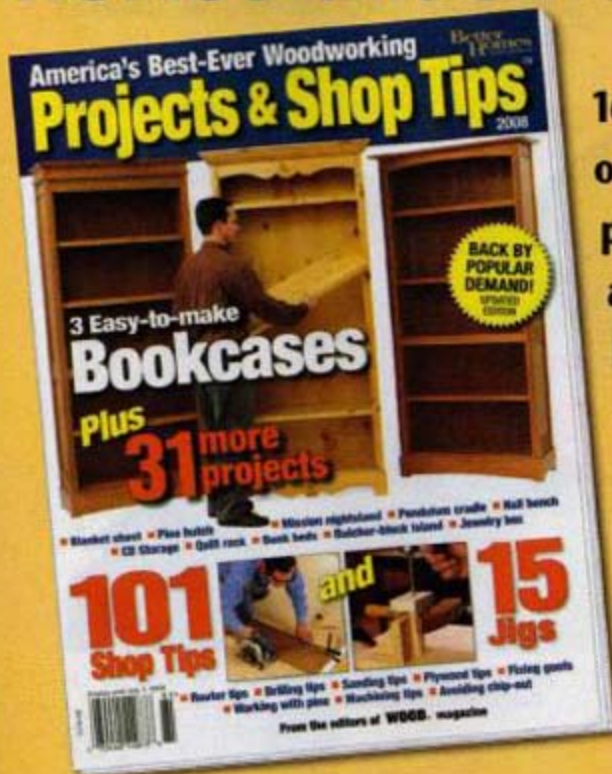

164 pages  
of heirloom  
projects  
and super-  
handy tips  
for all  
skill  
levels

Order online [woodmagazine.com/publications](http://woodmagazine.com/publications)  
or call toll free 888-636-4478

WD0308

## E-Z Woodworking

For the Professional and the Do-It-Yourselfer



### E-Z Pocket Hole Jig Kit

Award Winning Ingenuity!

#### Kit Includes

- 1 Pocket Hole Jig with Clamp
- 3/8" Step Drill Bit & Drill Stop with Hex Wrench
- 3 Drill Stops: 1/4", 5/16" 3/8" & Hex Wrench
- 6" Steel Square Drive Bit
- Square Drive Screws
- Free Project Plans Included

NO. 849

#### Smart Design

- Heavy duty aluminum extrusion & hardened steel drill bushings
- Built to be portable or bench mounted, and designed with a built-in clamping system

#### Makes Three Types of Pocket Hole Joints

- Flush, Corner & Angle



Woodworking Made Easy!

[www.generaltools.com/EZ](http://www.generaltools.com/EZ)

Circle No. 785

**GENERAL**

General Tools & Instruments™

80 White Street, New York, NY 10013-3567  
TEL: 212. 431. 6100 TOLL FREE: 800. 697. 8665  
sales@generaltools.com www.generaltools.com

"It's your job . . .  
General Tools make it easier!"

## Forrest Sharpening

Helps Prevent Bad Cuts Like These

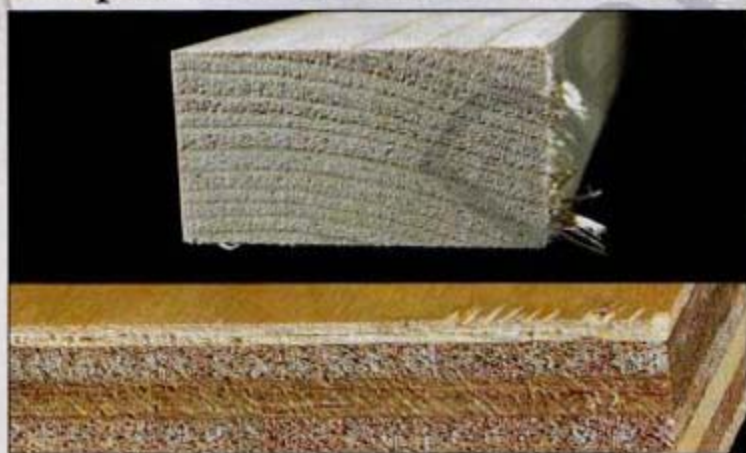

Abrasion, pitch buildup, micro chipping and poor sharpening jeopardize the life and performance of even the finest carbide-tipped blades and dado sets. Our expert factory sharpening will help protect your investment. We handle all types and makes of blades. Typical turnaround is just 4 to 5 days.

We've been the leader for over 60 years, so contact us today.

**FORREST**

The First Choice of Serious  
Woodworkers Since 1946

[www.ForrestBlades.com](http://www.ForrestBlades.com)  
1-800-733-7111  
(In NJ, call 973-473-5236)

© 2007 Forrest Manufacturing

Code WM

Circle No. 205

PRECISION MILLED TEETH | INDUCTION HARDENED  
FLEXBACK CONSTRUCTION | MATCH TOOTH WELDED

"STAYS  
SHARP  
MUCH,  
MUCH  
LONGER."

**Carter classic**  
bandsaw upgrades

**AccuRight™  
Bandsaw  
Blades**

A new standard  
for precision  
and durability.

From the company  
that has been making  
bandsaws better  
for over 75 years.

Buy three bandsaw blades.  
Get FREE "Bandsaw Tuning" DVD.  
(\$14.95 Value)

**Carter products**

Circle No. 176

[www.carterproducts.com](http://www.carterproducts.com) | Toll-Free 888.622.7837

# Shop-Proven Products

These woodworking wares passed our shop trials.

## Sliding crosscut table delivers spot-on precision

Priced at \$550, this accessory costs more than some tablesaws. But if you demand the same level of precision and reliability from your tools as you do in your furniture-making, you'll see the JessEm Mast-R-Slide as an investment.

This add-on replaces the left wing on any cast-iron-top tablesaw (right or left tilt) with a front-to-rear depth of 27–28". It comes predrilled to mount in the same holes where the wing was mounted, so installation is a snap. However, to accommodate the sliding table, you'll have to cut off the portion of your saw's fence rails that extends beyond the tabletop where the left wing was mounted. After installing the Mast-R-Slide, I leveled it to the tabletop and aligned it with the blade in just a few minutes.

I found I could crosscut a workpiece up to 36" wide with the Mast-R-Slide. (The fence mounts in three locations, shown at right.) You can make miter cuts up to 70° in both directions, and I found the degree markings dead-on (although the scales stop at 45°). The fence measures 30", but extends to 48" and still uses the movable stopblock. When you're not making crosscuts, the sliding table locks in position, and the fence detaches easily.

Crosscutting hardwood stock and sheet goods proved easy, accurate, and repeatable with the Mast-R-Slide. The 30 sealed bearings made for smooth sliding, regardless of what size workpiece I was cutting. For boards longer than 4' and wider than 6", though, you'll likely need to add work supports to avoid tipping and ensure precise cuts.

—Tested by Chuck Hedlund

## About our product tests

We test hundreds of tools and accessories, but only those that earn at least three stars for performance make the final cut and appear in this section.



Mount Mast-R-Slide's fence in position A for most of your 90° crosscuts, position B for miters up to 45°, and position C (with the fence front facing you) for maximum width 90° crosscuts.

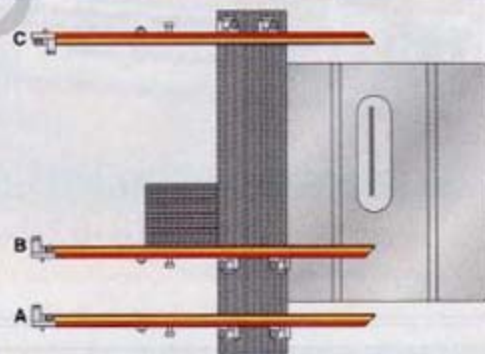

### Mast-R-Slide, model #7500

Performance	★★★★★
Price	\$550
JessEm	
866-272-7492; jessem.com	

## Portable worktable holds up to tough use on the job and at home

I've used a Black & Decker Workmate for years, and found it to be a handy helper in the shop and on a job site. Black & Decker's new Firestorm Portable Clamping Workstation expands on that versatility. It features a thick 23×36" plastic worktop and shelf, connected to four sturdy, tubular aluminum legs. It measures 36" to the top of the work surface, and folds easily into a lightweight suitcase shape.

Clamping separates this from other workstations. Two slotted tracks built into the top accept proprietary one-handed bar clamps. (Two are included with the table—you can buy more.) I clamped everything from hardwood to plywood to plastic to steel pipe, and the clamps held each material securely as I routed, sawed, hammered, planed, and sanded. Despite the mostly plastic construction, the unit proved surprisingly steady and solid. I clamped my benchtop tablesaw to the top for work on a job site, and it held securely without wobbling. (The Workstation supports up to 400 lbs.) You can use the clamps to grip workpieces horizontally or vertically with equal control. There's also open slots for clamping pieces to the middle of the table.

—Tested by Steve Feeney



### Portable Clamping Workstation, #FSWM1000

Performance	★★★★★
Price	\$90
Black & Decker	
800-544-6986; firestormtools.com	

## Breathe a sigh of relief and clean air with QuickLatch

We all know we should avoid breathing wood dust and overspray from wood finishes, but those annoying paper masks are uncomfortable and usually of little good. That's why I think the QuickLatch Pro is a great value: It combines ultrafine filtration with all-day comfort. The QuickLatch Pro features dual filters that trap particles down to 0.035 microns—that's dust, solvents, finishes, paint, mold, and pesticides—allowing only clean, breathable air through the mask.

The QuickLatch Pro slipped over my head easily, covering my nose and mouth. I pulled the straps tight behind my neck for a good seal. The hinge-like latch releases the respirator quickly, allowing it to drop below my chin, and then just as quickly tightens it up—all with one hand.

—Tested by Pat Lowry

### QuickLatch Pro Multi-Purpose Respirator

Performance	★★★★★
Price	\$50
AOSafety aosafety.com	

## Leave your sander running and save production time

Nearly everyone wishes they could have more time for doing the things that mean the most. If sanding is not one of those things, then the Orbital Station will save you time for better things. This handy accessory mounts to a wall or bench or even in a vise, and holds your electric sander—while it's running—so you can reposition or flip your workpiece. Admittedly it's not going to save hours, but if you're sanding all day, it will shave a few minutes from your job.

I used the Orbital Station with a 5" random-orbit sander and a quarter-sheet palm sander, and its adjustable and sturdy metal jaws gripped each one securely without them vibrating loose. At first I was hesitant to trust it, but I quickly learned that I could. Now, I appreciate the freedom it provides.

—Tested by Steve Feeney

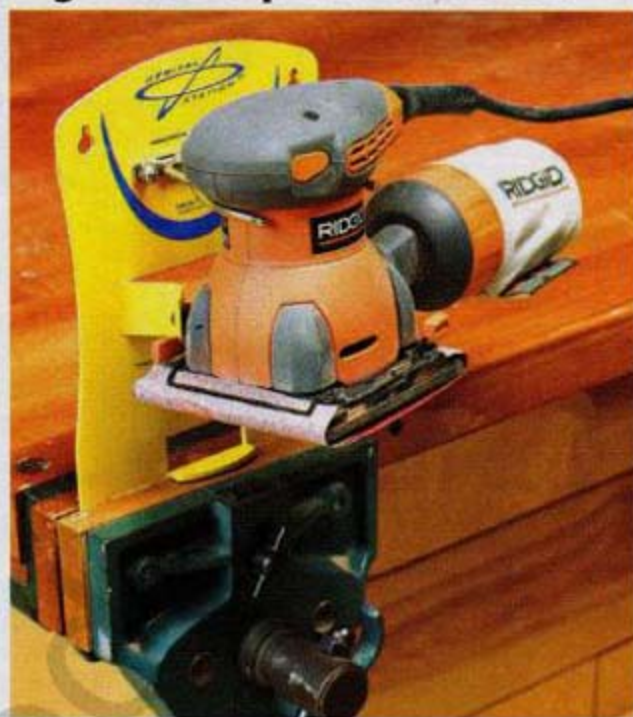

### Orbital Station

Performance	★★★★★
Price	\$25
Orbital Station orbitaltoolstation.com	

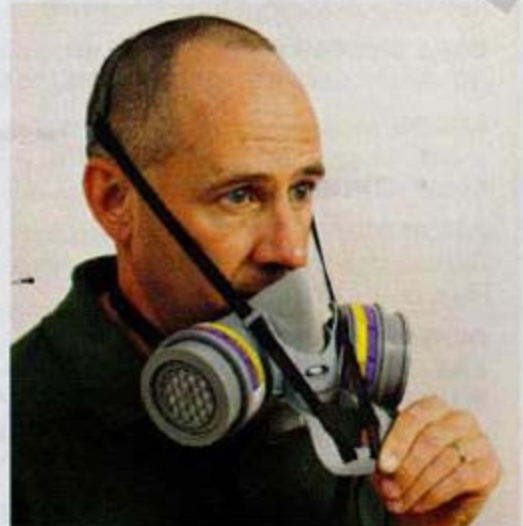

1-800-824-4894 www.zimmer.com © 2007 Zimmer Laboratories, Inc.

## YOU GOT FUNGUS? NAIL IT!

with

**FUNGI NAIL** BRAND

- ✓ Maximum Strength without a Prescription
- ✓ Twice the Strength of Other Brands
- ✓ Visible Results in Just Weeks
- ✓ No Side Effects

**#1**  
Pharmacist  
Recommended

**FREE!**

Nail care set and  
brochure on how to  
**NAIL** your fungus!  
Call 1800-824-4894

AVAILABLE AT:



WAL-MART

## FREE Product Information from Advertisers in This Issue

Looking for FREE product information? Fill out the coupon in this section to receive FREE product info and catalogs. Or, for quicker service and instant access to information, visit us online at [www.woodworkerscenter.com](http://www.woodworkerscenter.com)

### Adhesives & Finishes

#### DONJER PRODUCTS CORPORATION

Spray-on suede. Line boxes in seconds. No skill required. **Circle No. 17.**

#### TITEBOND® III ULTIMATE WOOD GLUE

Superior bond strength, waterproof, longer open-assembly time. The Best Wood Glue Ever! **Circle No. 24.**

#### THE GORILLA GLUE COMPANY

Bonds wood, stone, metal, ceramic, and more. Incredibly strong — 100% waterproof. **Circle No. 50.**

#### VARATHANE

Varathane Premium Polyurethane helps you achieve professional results when refinishing your wood floors. **Circle No. 118.**

#### UNITED GILSONITE LABORATORIES

Finishing Touch Brochure — guide for best results using ZAR Wood Stain/Finishes. **Circle No. 128.**

#### UNITED GILSONITE LABORATORIES

Hardwood Floor Guide — step-by-step finishing instructions using ZAR Wood Stain/Finishes. **Circle No. 154.**

### Bits, Blades, Cutting Tools

#### CARTER PRODUCTS COMPANY, INC.

AccuRight Bandsaw Blades — length 72" to 136", widths 1/8" to 1". **Circle No. 176.**

#### FLEXCUT CUTTING TOOLS

Carving tools for every need. **Circle No. 195.**

#### FORREST MFG. CO., INC.

Top quality blades and dados for an ultra smooth finish. **Circle No. 206.**

#### FREUD SAW BLADES

This 48-page catalog illustrates the features and benefits for all Freud saw blades. **Circle No. 219.**

#### FREUD ROUTER BITS

All Freud router bits are represented in this 84-page catalog, including more than 130 new bits and sets. **Circle No. 232.**

#### INFINITY CUTTING TOOLS

Premium quality router bits/sets, shaper cutters, saw blades, planer/jointer knives. **Circle No. 235.**

### Books, Plans and Videos

#### AMERICAN FURNITURE DESIGN CO.

150 of America's best furniture plans, comprehensive instruction guide. Catalog. **Circle No. 336.**

#### U-BILD WOODWORKING PLANS

Since 1948! Hundreds of full-size plans, downloadable plans, low prices. **Circle No. 435.**

### General Woodworking Catalogs

#### EURO 32 PRODUCTS

Hole-boring system and European hardware at competitive prices. **Circle No. 578.**

**GRIZZLY INDUSTRIAL, INC.** 12,000 woodworking and metalworking machines, tools and accessories — unbeatable prices! **Circle No. 583.**

**HARTVILLE TOOL CATALOG** Quality woodworking tools and supplies at the best prices around. **Circle No. 596.**

**WOODCRAFT SUPPLY CORP.** Over 15,000 top quality woodworking tools, supplies, and accessories. **Circle No. 700.**

### Hand Tools, Jigs & Clamps

#### ADJUSTABLE CLAMP COMPANY

Adjustable Clamp Company manufactures a full line of woodworking clamps, miter saws and vises. **Circle No. 733.**

**GENERAL TOOL E•Z POCKET HOLE JIG KIT** Features three E•Z pocket hole joints. **Circle No. 785.**

**KREG TOOL CO.** Your one stop shop for everything Pocket-Screw related. **Circle No. 802.**

#### DOWELMAX JOINT-MAKING SYSTEM

Dowelmax creates joints which are quick, easy, accurate, and strong. **Circle No. 825.**

**TOOLS FOR WORKING WOOD** Our 100-page catalog has some of the finest woodworking tools available today. **Circle No. 830.**

### Hardwood & Lumber

**CURIOUS WOODS** Superior quality hardwoods, for superior results. Domestic and Exotics. **Circle No. 842.**

**M.L. CONDON COMPANY** Single, convenient source for lumber, plywood, mouldings, custom millwork, more. **Circle No. 844.**

**STEVE H. WALL LUMBER CO.** Quality hardwoods, plywood, exotic lumber. Ship UPS/motor freight, wholesale prices. **Circle No. 856.**

**WOODWORKERS SOURCE** Hardwoods from around the world. **Circle No. 869.**

### Income Opportunities & Education

**FURNITURE MEDIC** Offering franchise licenses to qualified individuals to perform mobile, on-site furniture repair & restoration services. **Circle No. 895.**

### Kits

**DETAILED PLAY SYSTEMS** Wooden swingsets and playground equipment for the backyard. Free catalog. **Circle No. 958.**

**MUSICMAKER'S KITS** Kits, plans, & supplies for making beautiful acoustic instruments. **Circle No. 979.**

**PYGMY BOATS** Computer-designed, precision pre-cut, ultra-light wood boat kits/plans. **Circle No. 983.**

**ROUEBUSH COMPANY INC.** The most unique woodworking kits you'll find. **Circle No. 986.**

### Miscellaneous

**AZTEC STEEL CORP.** Quality pre-engineered arch-style steel buildings at the lowest cost anywhere. **Circle No. 1064.**

**DAKOTA ALERT, INC.** An alert sounds in the house when someone enters the drive. **Circle No. 1129.**

**FUNGI-NAIL ANTI-FUNGAL SOLUTION** Eliminate embarrassing finger & toe fungus with #1 pharmacist recommended Fungi-Nail anti-fungal solution. Contains the maximum strength available without a prescription! **Circle No. 1228.**

**SCHROEDER LOG HOME SUPPLY** Your log home care center. Free catalog. **Circle No. 1319.**

### Power Tools

**BAKER PRODUCTS** Industry leader for portable sawmills, resaws and woodworking equipment. **Circle No. 1428.**

**BATTERY RECYCLING CORP.** When the rechargeable batteries in your cordless power tools die, recycle them! **Circle No. 1438.**

**CARVEWRIGHT WOODWORKING SYSTEM** Computer controlled carving machine. **Circle No. 1463.**

**COOK'S SAW MFG., L.L.C.** Portable sawmills, Edgers, Sharpeners, Band Blades... Free catalog. Video available. **Circle No. 1480.**

**THE CRAFTSMAN GALLERY** Router Boss joinery machines and other quality woodworking tools and accessories. **Circle No. 1495.**

**DRILL DOCTOR** Sharpen your dull and broken drill bits with The Drill Doctor. **Circle No. 1511.**

**EPILOG** Wood engraving and cutting systems — Low Price, High-Quality Laser Systems. **Circle No. 1515.**

**FREUD POWER TOOLS** 16-page catalog illustrates dependable power tools with traditional Freud quality. **Circle No. 1532.**

**GENERAL, GENERAL INTERNATIONAL AND EXCALIBUR BY GENERAL INTERNATIONAL** A complete line of quality woodworking machinery & accessories. **Circle No. 1552.**

**GRANBERG INTERNATIONAL** Alaskan Saw Mill, chain saw accessories. Made in USA. **Circle No. 1558.**



**WORK SHARP** Sharpen your woodworking tools with the new WORK SHARP. **Circle No. 1665.**

**PANEL PRO VERTICAL PANEL SAW** Economical panel saw makes handling and cutting wood/plastic sheets easy. **Circle No. 1708.**

**SHOPBOT TOOLS INC.** Complete CNC systems for applications in wood, plastic and metal. **Circle No. 1714.**

**TOOLMART INC.** Makita, DeWalt, Porter-Cable, Milwaukee, Bosch, Freud. **Circle No. 1770.**

**WOODMASTER TOOLS** Multi-duty planers that mold, sand & saw. **Circle No. 1820.**

**WOODSTOCK INTERNATIONAL, INC.** SHOP FOX Woodworking Machines offering professional-level quality. Dealer supplied. **Circle No. 1824.**

### Project Parts & Materials

**ADAMS WOOD PRODUCTS** Offers a free catalog of their stock solid wood components. **Circle No. 1831.**

**OSBORNE WOOD PRODUCTS, INC.** A free catalog of table legs, corbels, and island legs. **Circle No. 1849.**

**OSBORNE WOOD PRODUCTS, INC.** WOOD CORBELS offer classic corbels in a broad range of styles. **Circle No. 1851.**

**WILDWOOD DESIGNS SCROLLSAW PATTERNS** Up to 74" clocks, 300+ patterns, books, clock parts, saw blades, tools, wood! **Circle No. 1857.**

### Shop Accessories

**BENCH DOG INC.** Router tables, power tool accessories. Receive Bench Dog Inc.'s current catalog of exceptional tools. **Circle No. 1870.**

**CARTER PRODUCTS COMPANY, INC.** Bandsaw Guide kits, tires, stabilizer guides, and many other products. **Circle No. 1883.**

**ONEIDA AIR SYSTEMS, INC.** Free informative catalog contains dust collection systems and complete ductwork. **Circle No. 2039.**

**PENN STATE INDUSTRIES** Award-winning dust collection. Collectors, Cyclones, Ductwork and more. **Circle No. 2045.**

### Woodturning Supplies

**BEREA HARDWOODS** Quality pen kits and other turning kits. **Circle No. 2127.**

**PACKARD WOODWORKS** Free Catalog for WOODTURNERS! — Quality Lathes, Tools and Supplies. **Circle No. 2143.**

**PENN STATE INDUSTRIES** Leading supplier of Turning Products. Pen kits, project, finishes and more. **Circle No. 2151.**

# Available on Newsstands NOW!



Find dozens of ideas and plans to improve your shop by reviewing these hardworking shops from the US and Canada.

\$6.99 U.S.  
\$8.99 Canada

Order online [woodmagazine.com/publications](http://woodmagazine.com/publications)  
or call toll free 888-636-4478

WD0308

## WOODWorkersCenter.com

DEPT. W0JJ08

### FREE Product Information

CIRCLE THE NUMBERS BELOW CORRESPONDING TO ITEMS IN THIS ISSUE.

17	205	583	842	986	1480	1708	1857	4000
24	206	596	844	1064	1495	1714	1870	
50	219	700	856	1129	1511	1770	1883	
118	232	733	869	1228	1515	1820	2039	
128	235	785	895	1319	1532	1824	2045	
154	336	802	958	1428	1552	1831	2127	
176	435	825	979	1438	1558	1849	2143	
195	578	830	983	1463	1665	1851	2151	

Discover how rewarding woodworking can be! Get one full year of WOOD® for just \$28.00 (7 issues). Simply circle No. 4000. You will be billed later.

NAME \_\_\_\_\_  
ADDRESS \_\_\_\_\_  
CITY \_\_\_\_\_ STATE \_\_\_\_\_ ZIP \_\_\_\_\_  
E-MAIL ADDRESS \_\_\_\_\_  
PHONE (OPTIONAL) \_\_\_\_\_

TO ENSURE PROMPT HANDLING OF YOUR ORDER, PLEASE:  
• Circle Your Choice(s) in the box above  
• Send card to  
WOOD® Magazine, Dept. W0JJ08,  
P.O. Box 5135, Buffalo, NY 14205-5135  
• Allow 4-6 weeks for delivery  
• This card expires November 13, 2008

**DETAILED**  
Play Systems

Backyard  
Playground  
Equipment

FREE CATALOG!

Just Add  
Lumber!

FREE SMILES!

Do it Yourself and Save!  
[www.detailedplay.com](http://www.detailedplay.com)  
1-800-398-7565

Circle No. 958

**ROUTER BOSS**

Multi-Purpose Routing Jig

One tool,  
any wood joint

**NEW**

Guides router for:

- mortises
- tenons
- dovetails
- raised panels
- dados & grooves
- and a lot more!

The  
Craftsman  
Gallery

Call 866.966.3728  
or visit [www.chipsfly.com](http://www.chipsfly.com)

Circle No. 1495

**H L & M** **LAKELAND FLORIDA**  
Est. 1988 863/646-8681

**Hardwood Lumber & Millwork**

Over 50 Species in stock  
Plywoods - Turning Stock - Mouldings  
Stair Parts - Architectural Millwork

Pull your own wood - Import & Domestic  
Discounts on 100 and 300 bd ft of lumber  
Rough cut or surfaced to your specs

Largest retail distributor in Florida

Hours of Operation M-F 9-5, Sat by appt

**Make Beautiful Log Furniture**

**With Tenon Cutters!**

**ASK US!**  
1-800-359-6614

Two New Cutter Styles to Choose From!

**REQUEST A FREE CATALOG**  
[www.loghelp.com](http://www.loghelp.com)

**Tenon Cutter System**

**SCHROEDER LOG HOME SUPPLY, INC.**

- ◆ Backer Rod
- ◆ Black Iron
- ◆ Books
- ◆ Caulking
- ◆ Chinking
- ◆ Cleaners
- ◆ Fasteners
- ◆ Finishes
- ◆ Foam Sealants
- ◆ Preservatives
- ◆ Restoration Products
- ◆ Sealants
- ◆ Tools
- ◆ Wood Treatments

Same day shipping from IN, MN, MT, and TN

Quality Log Home Care Products,  
Tools, And So Much More!

Circle No. 1319

**HARDWOOD MOULDINGS**

**THOUSANDS of profiles**  
ANY Length • ANY Specie

256-pg  
Moulding Catalog  
\$40 + \$10 s&h

**M.L. CONDON COMPANY Inc.**

Call for a **FAST, FREE QUOTE**  
236 Ferris Avenue, White Plains, NY 10603  
Phone: (914) 946-4111 • Fax: (914) 946-3779

Circle No. 844

**TUDOR BENCH**

Introducing the finest plan on the market today! Pages of directions and 36 by 48 CAD generated plan. Classic English design.

**FREE CATALOG**

**AMERICAN FURNITURE DESIGN**  
P.O. BOX 360109 ESCONDIDO, CA 92030  
TUDOR BENCH PLAN \$15.95 +\$5.00 S&H  
760 743-6923  
[www.americanfurnituredesign.com](http://www.americanfurnituredesign.com)

Circle No. 336

**SUEDE-TEX SPRAY-ON FIBERS**

Line boxes in seconds • No cutting  
• No pasting...no skill required!

Available in 30 + colors

Call for **FREE** brochure with sample of finish enclosed

**DONJER PRODUCTS**  
13142 Murphy Rd., Winnebago, IL 61088  
800-336-6537 • 815-247-8775 (outside the US)  
[www.donjer.com](http://www.donjer.com)

Circle No. 17

**A Serious Panel Saw at a Great Price! PRO**

Unassembled panel saw kits will cost between \$400-\$500. The Panel Pro™ is a complete system that will give you safe, fast and accurate cuts every time at a price that won't wipe out your budget.

- Vertical design makes it very easy to cut large sheets of material.
- Portable and lightweight for easy transportation to the job site.
- Factory aligned, means minimal set up is required.

To place an order or for information  
800-599-1655 • [www.panelpro.com](http://www.panelpro.com)

**PANEL PRO**  
Vertical Panel Saw

Only \$799.90 Plus Freight

See the Panel Pro in Action Online!  
[www.panelpro.com](http://www.panelpro.com)  
13543 Lincoln St.  
Hann Lake, MN  
55924 USA

Circle No. 1708

**Cut Your Own Wood!**

With the MP-32 Sawmill you can cut your own lumber for a Home, Fence, Furniture, and much More!

Affordable, Powerful, & Reliable! Call for your **FREE** Catalog today!

**Cook's Saw Mfg., LLC**  
1-800-473-4804

[www.cookssaw.com](http://www.cookssaw.com)

Circle No. 1450

## Woodworking Made Easy!

### FOREDOM WOODCARVING KIT

Features a 1/8hp reversible ball bearing motor.  
Variable speed from 0-10,000rpm.  
Hang up model has a 3/4" flex shaft.  
Complete with electronic foot control,  
\$44 handpieces with 3/32", 1/8", and 1/4" collets,  
wrench, grease, and a 12pc. accessory kit to get you started.

FT524.....Foredom Reversible Kit.....\$199.95  
Add \$8.95 per order for shipping

Full Color 100 Page Catalog Free With Any Order  
\$5.00 US & CANADA — \$10.00 INTERNATIONAL

1-800-351-8900

JANTZ SUPPLY

309 WEST MAIN-DEPT WD - DAVIS OK 73030

www.knifemaking.com

Knife making kits, Metals, Exotic Woods, Horn, Pearl, Ivory,  
Abrasives, Polishing And Finishing Supplies, Precision Tools,  
Schumacher and Leathercraft Supplies, Books, Videos, And More!

www.curiouswoods.com

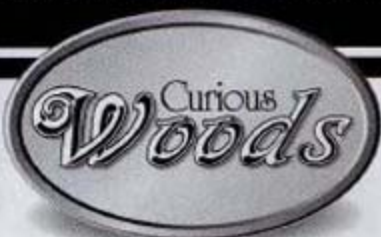

SUPERIOR QUALITY HARDWOODS...  
FOR SUPERIOR RESULTS.

Hand selected native and imported hardwoods,  
turning stock, burls, furniture grade plywood,  
veneers, and fine finishing oils.

Save 5% on your total order.  
Use promo code: WM5 at checkout.

Circle No. 942

## WORKSHOPS & GARAGES

Goes up fast - Built to last

Buildings start at \$12,000



If you can imagine the shop of  
your dreams you can build it.  
MiracleTruss building solutions  
save you time, money, & space.

Build the best. Expect the best.  
Build MiracleTruss.



MIRACLETRUSS  
STRENGTH | VALUE | STYLE

866-748-9921

miracletruss.com

## Adams Wood Products, Inc.

FURNITURE COMPONENTS  
STOCK ITEMS • NO MINIMUM  
CUSTOM COMPONENTS  
FREE COLOR CATALOG

WE WILL MAKE PRODUCTION RUNS OF YOUR PART

NEW ITEMS



A0753-12 A0755-12  
CORBELS



1032 Table Queen Anne Rams Head Claw/Ball



545 Bun 536 Bun  
530 Bun 537 Bun A0914 A0921 A0924  
ISLAND LEGS

P.O. Box 728, Dept. M60  
Morristown, TN 37815-0728  
Phone 423-587-2942 Fax 423-586-2188  
www.adamswoodproducts.com  
info@adamswoodproducts.com



Circle No. 1831

## BUILD A BETTER BANDSAW

blades  
guides  
tires  
tension devices

www.carterproducts.com  
toll-free: 888.622.7837

Circle No. 1883

## Musical

Kits, plans & supplies

800-432-5487  
www.harokit.com

Musimakers Kits  
PO Box 2117 - W08  
Stillwater, MN 55082

free catalog

Circle No. 979

## One Man Sawmill TURNS TIMBER INTO CASH

4 Models -  
Hobby to  
Super-Pro

NEW & Improved!

TIMBERKING  
Dept. ZB 02, 1431 N. Topping Ave., Kansas City, MO 64120

CALL TOLL FREE TODAY!  
FREE Fact Kit 1-800-942-4406  
www.timberking.com

## INFINITY NEW

CUTTING TOOLS

### Professional Coping Sled

Item: COP-100

Sale \$119.90

877-USA-BITS  
Visit infinitytools.com for the video

Circle No. 235

## Make Time!

Create your own wooden gear clock!

Need just the pattern? Or the complete kit? Build it *YOUR* way!

Wooden-Gear-Clocks.com  
clocks, kits, and do-it-yourself patterns

**(715) 955-4104**

www.wooden-gear-clocks.com

## The Woodturner's Source

Turning Tools  
Books & Videos  
Carving Tools  
Pen Supplies  
Lathes  
Chucks  
Sharpening

1-800-683-8876  
packardwoodworks.com

**Packard**  
WOODWORKS  
INC.

**Only \$48**

#43489

6" Digital Height Gauge with Fractional Display

Display Resolution: .01mm, .0005", 1/128"

**FREE Catalog!**

Easy-Read Horizontal Display

**Hartville Tool**  
WOODWORKING

hartvilletool.com  
800-345-2396

Circle No. 2143

Circle No. 595

# DOWELMAX

## MAKE A SOLID CONNECTION

### PRECISION ENGINEERED DOWEL JOINERY SYSTEM

**GOLD MEDAL WINNER AT THE TOMORROW'S WORLD SCIENCE FAIR, LONDON, ENGLAND**

- This kitchen cabinet was built with Dowelmax to create 14 precise face type, t-type and face frame, hardwood dowel joints for rock-solid construction.

*"Worth every penny!" "Five stars for sure!"  
"On the list of tools that exceeded expectations!"*

Our Guarantee: Joints stronger than a mortise & tenon. A system more accurate and versatile than any system on the market.

For more information, or to order call **1.877.986.9400**  
or log on to **www.dowelmax.com**

Circle No. 825

## U-BILD.COM

On-line catalog pictures hundreds of full-size woodworking plans at low prices, plus more than 30 downloadable plans. Indoor, outdoor, kids and holiday projects for all skill levels.

**(800) 82-U-BILD**

Circle No. 435



**Wildwood**  
DESIGNS INC.

2104 Beloit Ave  
Janesville, WI 53546

1-800-470-9090

**Excalibur**  
BY GENERAL INTERNATIONAL

21" & 30 Precision Scroll Saws

**Galaxy**

Scroll Saw Blades & Pin Nailers

SIMPLY WILD ABOUT SCROLL SAWING

www.wildwooddesigns.com

Circle No. 1857

## STOP BUYING LUMBER!

Use your chain saw and Granberg's mill to create perfect slabs of wood

- 1. MKIII Attachment**  
Easily mounts on Bar  
Saws from 24" to 54"
- 2. MINI MILL Attachment**  
Great partner for MKIII  
Ideal for edging, and reducing log diameters
- 3. SMALL LOG Attachment**  
Add to chain saw and start making lumber!

WWW.GRANBERG.COM  
CALL NOW FOR FREE CATALOG! 800-233-6499  
**50 Years of Customer Satisfaction!**

Circle No. 1558

## Wireless Driveway Alarm

Alerts you when someone is walking or driving onto your property.

**Dakota Alert**

PO Box 130, Elk Point, SD 57025  
605-356-2772 • www.dakotaalert.com

Free Literature

Circle No. 1129

Made in USA

## Tools for the Art of Woodcarving

**Flexcut**  
CARVING TOOLS

www.Flexcut.com

Woodcarvings by David Bennett

Circle No. 195

## HARDWOODS

Lumber • Veneer • Turning Stock

**exoticwoods.net**  
**800.423.2450**

Wood Descriptions • Secure Online Ordering



**WOODWORKERS**  
Source

18115 N. Black Canyon Hwy. • Phoenix, AZ 85023  
 645 W. Elliott Rd. • Tempe, AZ 85284  
 3441 S. Palo Verde • Tucson, AZ 85713

Circle No. 869

## SELF-SET®

### JOINTER / PLANER KNIFE

Effortless and Accurate  
 Blade Changes Every Time

Precisely Located Stops  
 on the SELF-SET Holder  
 Ensure Perfect Set-Ups  
 Every Time



## DISPOZABLADE

800-557-8092 .com



**AMERICAN STEEL SPAN®**

up to **60% SAVINGS!**

**Color Available!**

Great for Your Workshop  
 Ideal for Your Garage  
**Made in the USA**



**25 YEAR WARRANTY**

Designed with Protection in Mind  
**SOLID • SECURE • SAFE**

**800-891-6733**

www.steelspan.com ext. 618

Circle No. 1064

## Top-Rated Sea Kayaks

Rugged, Ultra-Light Beautiful Leader in Kayak Kits Since 1986



Call or write for our Free Catalog  
 (360) 385-6143, P.O. Box 1529, Dept 35  
 Port Townsend, WA, 98368  
 www.pygmyboats.com

Circle No. 983

### The Roudebush Company

The most unique woodworking kits you will find. Kits include everything to build these projects except the wood. Includes: Complete hardware and wheels, instructions and full-size patterns. Irish Mail Handcar Kit, \$59; 1901 Coaster Wagon Kit, \$79; Buckboard Bench Kit, \$59 plus shipping UPS.

The Roudebush Company, PO Box 348,  
 Star City, Indiana 46985.



800-847-4947 • woodkitsandplans.com

Circle No. 986

## Projects and Plans



### Wheelbarrow

Kit to build includes 15" iron wheel that really works, axle and step-by-step plans. Finished project measures 66"L x 24"W x 26"H. \$34.95 plus S/H

**ByeGone Workshop**  
**888-279-3941 8-5 M-F EST**  
 www.bye-gone.com

### BereaHardWoods.co., Inc.

Quality Kits for Making Wooden Barrel Pens, Pencils, Roller Balls and Fountain Pens plus other related items Wholesale/Retail

VISIT OUR NEW WEB SITE:  
 www.penkits.com



Circle No. 2127

### Walking the talk.



Hand tools for the serious woodworker

**TOOLS FOR WORKING WOOD**

800.426.4613  
 32 33rd St. Bklyn, NY 11232 www.toolsforworkingwood.com

Circle No. 830

## Introducing The Euro 32™ Hole-Boring System



Simplifying Hole-Boring For Frameless Cabinets!™

To learn more about the Euro 32™ and to find European Style hardware at competitive prices Visit us at  
 www.euro32products.com

Circle No. 578

## STEVE WALL LUMBER CO.

Quality Hardwoods and Woodworking machinery For The Craftsman and Educational Institutions

Ash	4/4	Select	\$ 2.90		\$ 94.00
Basswood	4/4	Select	\$ 1.95		\$ 80.00
Birch	4/4	Select	\$ 3.55		\$ 108.00
Butternut	4/4	1C	\$ 2.95		\$ 88.00
Cherry	4/4	Select	\$ 4.90		\$ 117.00
Hickory - Pecan	4/4	Select	\$ 3.00		\$ 100.00
Mahogany (Genuine)	4/4	Select	\$ 4.70		\$ 112.00
Maple (Hard)	4/4	Select	\$ 3.45		\$ 108.00
Maple (Soft)	4/4	Select	\$ 2.50		\$ 88.00
Poplar	4/4	Select	\$ 1.80		\$ 78.00
Red Oak	4/4	Select	\$ 2.70		\$ 96.00
Walnut	4/4	Select	\$ 4.90		\$ 115.00
White Oak	4/4	Select	\$ 2.70		\$ 96.00
Cedar (Aromatic Red)	4/4	1C+Btr.	\$ 1.80		\$ 78.00
Cypress	4/4	Select	\$ 2.60		\$ 90.00
White Pine	4/4	F.G.	\$ 1.25		\$ 70.00
Yellow Pine	4/4	Clear	\$ 2.30		\$ 82.00

Above prices are for 100' quantities of kilndried rough lumber sold by the Bd. Ft. FOB Mayodan, NC. Call for quantity discounts. Other sizes and grades available.

Above prices are 20 bd. ft. bundles of clear kilndried lumber 3"-10" wide • 3'-5' long (Random widths & lengths) Surfaced 2 sides or rough. Delivered UPS prepaid in the Continental U.S.

**UPS Specials**

SEE OUR CATALOG ON THE WEB!

OLIVER MACHINERY DEALER

HARDWOOD PLYWOOD

CUSTOM RAISED PANEL DOORS

CUSTOM PLANK HARDWOOD FLOORING

THIN CRAFTWOOD

EXOTIC LUMBER

**STEVE H. WALL LUMBER CO.**

BOX 287  
 MAYODAN, N.C. 27027  
 336-427-0637  
 1-800-633-4062  
 FAX 336-427-7588

Email: wood@walllumber.com  
 Website: www.walllumber.com

Send \$1.00 For Lumber Catalog  
 Prices Subject to Change Without Notice

Circle No. 856

# What's Ahead

A sneak peek inside the September issue (on sale July 15)

## FEATURED PROJECT



### Build-to-your-liking showcase

We've finally done it: After more than 20 years and hundreds of requests, we've designed a gun cabinet. With a few simple modifications—glass shelves and a mirror back—you can use the same plan to build a handsome display cabinet. We'll show you both.



### Kid's crane

This fully operational mobile toy will keep those young builders on your gift list busy, and you'll have an uplifting time making it.



### Rolling shop bench

Here's the perfect project for a small shop. One side folds out to more than double its worksurface and reveal hanging-tool storage. The other side features five simple-to-make drawers.

## TOOL TEST



### Value-priced 14" bandsaws

In our search for the best machine under \$500, we put eight models through rigorous testing. Find the lowdown on where to invest your money.



### Hardware items for better jigs

Discover how to make your woodworking jigs more versatile, spot-on accurate, and workshop tough using readily available parts.



### No-math shop geometry

Learn six simple and essential methods for getting the angle on bisecting lines, drawing ovals, and forming various multisided shapes.

# The facts are hard to ignore.

Titebond® III outperforms polyurethane glues.

Reference Guide

## Glue comparison

What woodworkers need to know!

	Titebond III	Polyurethane Glues
Higher Bond Strength	✓	✓
Exterior Use - Waterproof	✓	
Easy Water Cleanup	✓	
Much Safer To Use	✓	
Shorter Clamp Time	✓	
No Foam - Less Mess	✓	
Shorter Open Time	✓	✓
Doesn't Stain Skin	✓	✓
Bonds Most Materials	✓	
Bonds Oily / Exotic Woods	✓	
Lower Cost - Better Value	✓	
Longer Usable Shelf Life	✓	

Woodworking Handbook 2007



As the leader in wood glues, we want you to know the truth about polyurethane glue and woodworking. A straightforward comparison between Titebond® III Ultimate Wood Glue and polyurethane glue tells the story.

Titebond® III is THE ultimate choice for bonding wood to wood. Period.

For more information and a detailed comparison, please visit [www.titebond.com/TBIIIvsPolyurethane](http://www.titebond.com/TBIIIvsPolyurethane)

Proud Sponsor Of

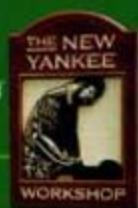

Made in the USA

# SEE ALL THOSE CALL-OUTS BELOW?

THE FEATURES ARE EVEN MORE IMPRESSIVE WHEN YOU EXPERIENCE THEM FIRSTHAND.

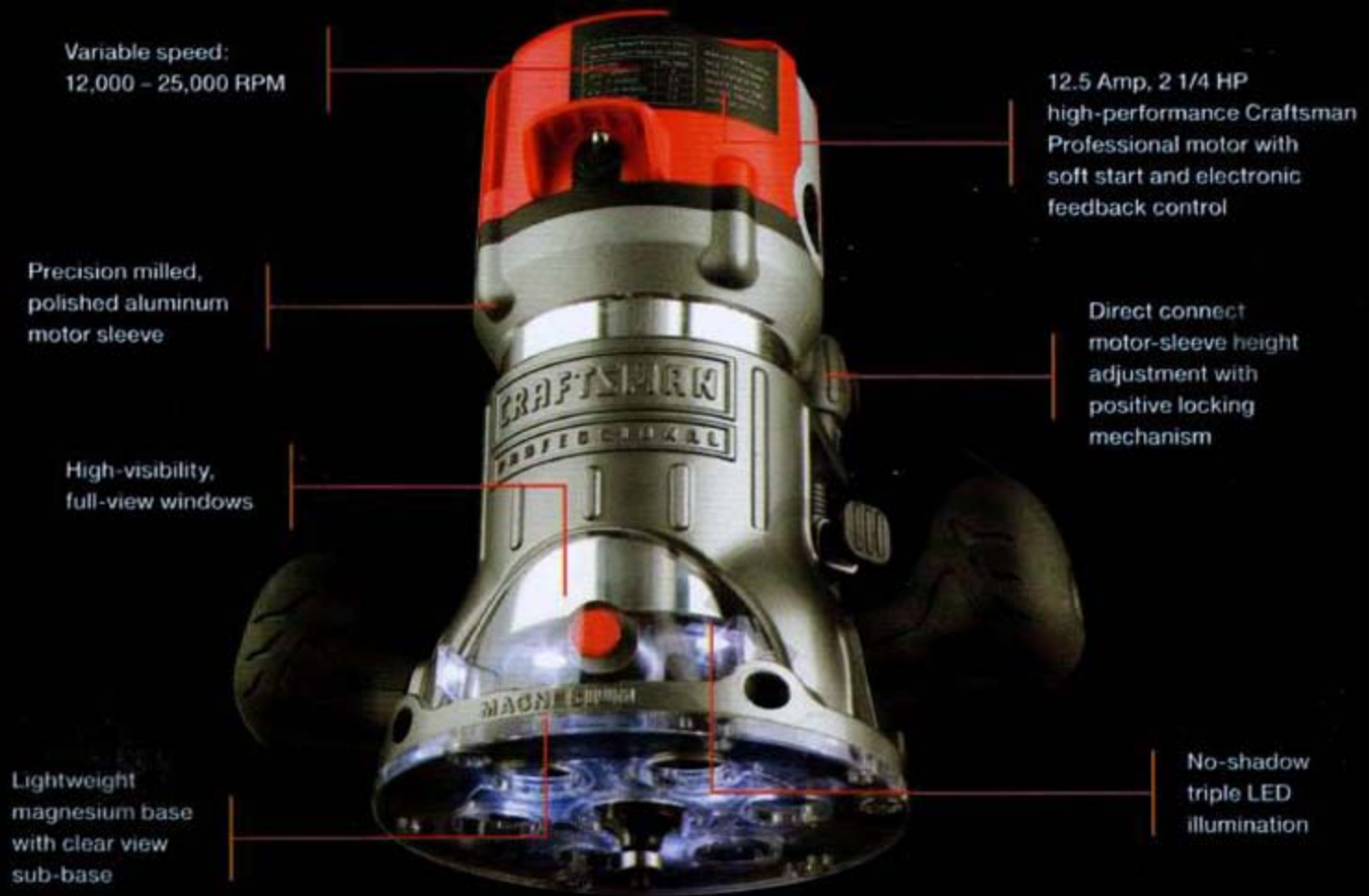

9.5 Amp  
Plunge Base



9.5 Amp  
Fixed Base



11 Amp  
Fixed Base



11 Amp  
2-Base Combo



6.5 Amp  
Palm Router



12.5 Amp  
Fixed Base



12.5 Amp  
3-Base Combo

Introducing the redesigned line of routers from Craftsman. Made even better by listening to people who use them for a living. More ergonomic for your comfort. Oversized dual-view windows to improve your sightline. We were told a lot of things, and we listened. Experience our new line of routers and give us your feedback. Available at Sears and [craftsman.com](http://craftsman.com)

Router features vary per model.

THERE'S A CRAFTSMAN IN ALL OF US

