

# WOOD

The World's Leading Woodworking Resource

Build  
Cabinets  
the  
**EASY WAY!**  
p.50

Make this  
easy, elegant  
**Glass-door  
Bookcase**  
p.34

## 3 Money-Saving Shop Jigs

- **Clamp Rack** p.56
- **Shelf-hole Jig** p.24
- **Cope-cutting Sled** p.32

## More Projects

- **Picnic Table** p.60
- **Tea Lights Holder** p.20
- **Jewelry Box** p.70



## FREE WEB VIDEOS:

- **Jointer/Planers Explained** p.66
- **Removing Router Burn Marks** p.22
- **How to Coil a Bandsaw Blade** p.18

Display until July 14, 2009



0 75

0 75

0 92567 14072 5

0 75

SECRETS OF  
CIRC SAW JOINERY p.26

in this issue

50



76

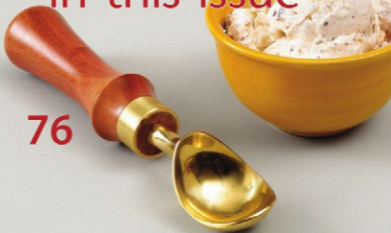

## PROJECTS

- 20 Make it From Scrap: Votive Holder
- 24 Quick & Easy Shelf Pin-hole Jig
- 32 Simple, Shop-mass Cope-cutting Sled
- 34 On the cover: Glass-door Bookcase
- 56 Hold-'em-all Clamp Rack  
This ingenious system accommodates any clamp style, and packs a lot of them into a compact space.
- 60 Outdoor Project: Picnic Table
- 70 Weekend Project: Jewelry Box
- 76 Turned Ice Cream Scoop

## TOOLS & MATERIALS

- 18 How to Coil a Bandsaw Blade
- 30 Wise Buys: Cope-cutting Sleds
- 41 Choosing From Today's High-tech Screws
- 66 Tool Test: 12" Joints/Planers  
These combo machines joint and plane stock up to 12" wide in the space of a typical 6" jointer.
- 80 Shop-Proven Products  
SawStop contractor-style saw, Euro-hinge boring jig, sliding mitersaw, and more.

## SKILL BUILDERS

- 22 3 Simple Fixes for Router-burned Edges
- 26 Secrets of Circular-saw Joinery
- 38 How to Cut Perfect Half-lap Joints
- 50 Cabinetmaking Made Easy  
Save money by building cabinets for anywhere in your home. No special tools required.
- 61 Getting the Most From 2x Lumber
- 72 Learn the Basics of Bookmatching
- 74 Tips for Working With Brass Parts

70



30



**BASIC-BUILT**  
GREAT PROJECTS MADE SIMPLE.

60



## DEPARTMENTS

- 6 Shop Tips
- 12 Sounding Board
- 14 Ask WOOD
- 92 What's Ahead

24





18



20

This seal is your assurance that we build every project, verify every fact, and test every reviewed tool in our workshop to guarantee your success and complete satisfaction.



66

# on the web

woodmagazine.com

## FREE ONLINE VIDEO: COMBINATION JOINTER/PLANERS DEMONSTRATED



Bob Hunter  
WOOD Magazine



Although common in Europe, machines that both joint and plane boards look foreign to many of us on this side of the pond. WOOD® magazine Tools Editor Bob Hunter explains how the machines work and shows how easily they switch from jointing to planing and back at [woodmagazine.com/woodcuts](http://woodmagazine.com/woodcuts)

## DUST BOWL: 21ST CENTURY EDITION

If John Steinbeck had a miter saw dust collector as efficient as this clear acrylic shell, built by Greg Little of Prairieville, La., perhaps he wouldn't have written all those depressing books. At [woodmagazine.com/shopsshots](http://woodmagazine.com/shopsshots) you'll find more solution-filled shop photos.



## MORE GREAT OUTDOOR PROJECT PLANS

Looking for more outdoor projects to help you while away the summer? At [woodmagazine.com/outdoor](http://woodmagazine.com/outdoor), you'll find dozens of plans for outdoor projects—from furniture like the bistro table (at left) to yard structures to birdhouses. Each shop-proven plan guarantees your success.



MARC ADAMS Technical Techniques VIDEO SERIES



13 years of experience in the wood industry. Now he's sharing his secrets with you.

FINISHING TECHNIQUES



FINISHING

## LEARN FINISHING FROM A MASTER

Woodworking guru Marc Adams answers all your questions about finishes, how they work, and how to successfully apply them in this 100-minute video. Download it for only \$19.95 from the Better Woodworking video library at [woodmagazine.com/videos](http://woodmagazine.com/videos)

**We asked our staff:**

What sparked your interest in woodworking?



It was the simple urge to create something beautiful and useful.

**EDITOR-IN-CHIEF**

**BILL KRIER**



A neighbor allowed me and other kids to glue together washpans from his workshop scraps. That set our woodworking creativity in motion.

- |   |  |
|---|--|
| <b>Managing Editor</b><br><b>MARLEN KEMMET</b>              | <b>Deputy Editor</b><br><b>DAVE CAMPBELL</b>             |
| <b>Art Director</b><br><b>KARL EHLERS</b>                   | <b>Senior Design Editor</b><br><b>KEVIN BOYLE</b>        |
| <b>Techniques Editor</b><br><b>BOB WILSON</b>               | <b>Tool &amp; Techniques Editor</b><br><b>BOB HUNTER</b> |
| <b>Multimedia Editor</b><br><b>LUCAS PETERS</b>             | <b>Multimedia Editor</b><br><b>CRAIG RUEGSEGER</b>       |
| <b>Design Editor</b><br><b>JEFF MERTZ</b>                   | <b>Associate Art Director</b><br><b>GREG SELLERS</b>     |
| <b>Production/Office Manager</b><br><b>MARGARET CLOSNER</b> | <b>Administrative Assistant</b><br><b>SHERYL MUNYON</b>  |

**Photographers**

**MARTY BALDWIN, JASON DONNELLY, DEAN SCHOEFFNER, JAY WILDE**

**Contributing Illustrators** **TIM CAHILL, LORNA JOHNSON, ROXANNE LeMOINE**

**Technical Consultants** **JEFF HALL, DOUG HICKS**

**Contributing Craftsman** **JIM HEAVEY**

**Contributing Proofreaders** **BABS KLEIN, IRA LACHER, JIM SANDERS**

**SUBSCRIBER SERVICE**

Go to [woodmagazine.com/help](http://woodmagazine.com/help) or write to WOOD magazine, P.O. Box 37439, Boone, IA 50037-0439

**Publisher** **MARK L. HAGEN**

**ADVERTISING AND MARKETING**

**CHICAGO:** 333 N. Michigan Ave., Suite 1500, Chicago, IL 60601

**Marketing Manager** **AMANDA SALHOOH**

**Advertising Manager** **JACK CHRISTIANSEN**

**Account Executive** **RYAN INTERLAND**

**Direct Response Advertising Representative** **LISA GREENWOOD**

**Assistant** **TIM BAARDA**

**ATLANTA:** Navigate Media

**DETROIT:** RPM Associates

**Business Manager** **JEFF STILES**

**Consumer Marketing Director** **TODD BIERLE**

**Associate Director of Marketing-Newsstand** **TOM DEERING**

**Production Manager** **SANDY WILLIAMS**

**Advertising Operations Manager** **JIM NELSON**

**E-Commerce Manager** **MATT SNYDER**

**Vice President/Group Publisher** **TOM DAVIS**

**MEREDITH PUBLISHING GROUP**

**President** **JACK GRIFFIN**

**Executive Vice President** **DOUG OLSON**

**Chief Revenue Officer** **TOM HARTY**

**Finance & Administration** **MIKE RIGGS**

**Manufacturing** **BRUCE HESTON**

**Consumer Marketing** **DAVID BALL**

**Corporate Sales** **MICHAEL BROWNSTEIN**

**Meredith 360°** **JEANNINE SHAO COLLINS**

**Interactive Media** **LAUREN WIENER**

**Corporate Marketing** **NANCY WEBER**

**Research** **BRITTA WARE**

**Chief Technology Officer** **TINA STEIL**

**New Media Marketing Services** **ANDY WILSON**



**President and Chief Executive Officer** **STEPHEN M. LACY**

**Chairman of the Board** **WILLIAM T. KERR**

**In Memoriam — E. J. Meredith III (1933–2003)**

Our subscribers list is occasionally made available to carefully selected firms whose products may be of interest to you. If you prefer not to receive information from these companies by mail or by phone, please let us know. Send your request along with your mailing label to Magazine Customer Service, P.O. Box 37432, Boone, IA 50037-0432.

© Copyright Meredith Corporation 2009. All rights reserved. Printed in the U.S.A.

**Retail Sales**

Retailers can order copies of WOOD for resale by e-mailing [jennifer.boone@meredith.com](mailto:jennifer.boone@meredith.com)



**YOUR CUTS  
AREN'T PERFECT.  
BUT IT'S NOT  
YOUR FAULT.**



And it's not your saw's fault either. The real problem... is your tape measure and pencil. Because you're measuring and marking each individual workpiece separately, you're getting small inconsistencies which add up in a hurry come assembly time. Our **Precision Trunk and Stop System** eliminates this problem and helps you make perfectly accurate cuts one after another with confidence.



**The modern replacement for  
your tape measure and pencil.**

**Unleash the full potential  
of ALL your saws!**



**Precision Miter Gauge**

Precision miters down to 1/10th of a degree, right out of the box.



**Precision Band Saw Fence**

One simple attachment means your Band Saw isn't just for rough cuts anymore!

**To see these products in action,  
visit us online at [www.kregtool.com](http://www.kregtool.com).**



# Shop Tips

Helping you work faster, smarter, and safer

## Instant conversion: tablesaw to downdraft table

Here's a quick and easy way to add a downdraft sanding table to your dust-collection system. Cut two pieces of hardwood to  $\frac{1}{2} \times 1\frac{1}{2} \times 18"$ . Then cut two cross-pieces from  $\frac{1}{4}"$  stock and assemble the frame, as shown, topping it with perforated hardboard.

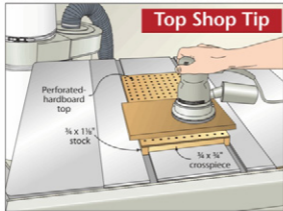

Lower the blade on your dust-collector-connected tablesaw, remove the throat plate, and center the downdraft table over the opening. Turn your

dust collector on, and you've got an instant downdraft table perfect for sanding small parts.

—Ed Perko, Mercer, Wis.

## New spin on finishing tables

I came up with this rotating stand when it was time to put a finish on a table. Made from a lazy-Susan bearing sandwiched between pieces of  $\frac{1}{2} \times 12"$ -diameter plywood, I gave it more reach by attaching four pivoting extension arms. The arms swing out to

hold large projects, and then fold up to stow away. Now I don't have to walk around the workbench; I simply rotate the workpiece without handling the fresh finish. And I'm always looking at the project from the best-lit angle.

—Larry Ormsbee, Cambridge, Ont.

continued on page 8

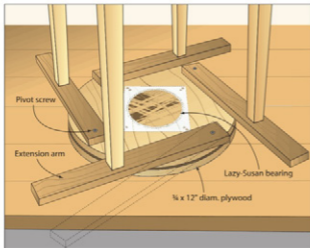

## The Top Tipster



Ed Perko went from being surrounded by people (while helping Fortune 100 companies with employee relations) to being surrounded by trees in semi-retirement on a lakeside acreage.

There, he is the model of self-sufficiency, clearing the land to build his home and harvesting trees for the furniture projects he creates in his basement workshop.



For submitting this issue's Top Shop Tip, we'll send some Forrest to Ed's shop in the woods. A Woodworker II, Dado King, and finger-joint set are on their way. Ed!

## Top tips earn tools!

Tell us how you've solved a workshop stumper. If we print it, you'll get \$100 and a copy of 450+ Best-Ever Shop Tips ([woodmagazine.com/450tips](http://woodmagazine.com/450tips)). And, if your idea garners Top Shop Tip honors, we'll also reward you with a tool prize worth at least \$300.

Send your best ideas, along with photos or drawings and your daytime phone number, to: **Shop Tips, WOOD Magazine, 1716 Locust St., L5-221, Des Moines, IA 50309-3023.** Or, by e-mail: [shoptips@woodmagazine.com](mailto:shoptips@woodmagazine.com). Include your contact info in the e-mail.

Because we try to publish original tips, please send your tips only to WOOD® magazine. Sorry, submitted materials can't be returned.





## CUSTOM TURNINGS!

Since 1979, we've been supplying furniture makers and craftsmen with unique wood turnings, table legs, kitchen island legs, sofa legs and more!

[www.osbornewood.com](http://www.osbornewood.com)

Need a unique size or shape?  
Send us your designs and we'll  
work with you to create the  
turning you need.

Making *your*  
designs into quality,  
finished turnings  
for your custom  
projects.

Sign up for E-letters to get updates  
about promotions, new products and woodworking tips at  
[www.osbornewood.com](http://www.osbornewood.com)

Order Line: 800.849.8876  
For a Catalog: 800.746.3233  
[info@osbornewood.com](mailto:info@osbornewood.com)

## Shop Tips

### Just take a little off the top

To avoid running a delicate piece, such as inlay, through a potentially destructive planer, I found a good way to safely secure the piece while sanding it to thickness. I clamp a scrap piece of plywood to the workbench and rout a recess as deep as the final workpiece thickness, and to roughly the shape. I can then drop the piece into the recess and sand or scrape the piece until it is even with the surface of the plywood scrap.

—Rick DeFazio, North Olmsted, Ohio

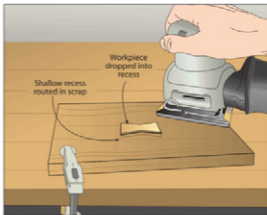

### Simple and sticky patterns

As I was making the scrollsawn Christmas ornaments from the November 2007 issue (no. 180), I discovered a tip I'd like to share. Rather than deal with messy spray adhesive or time-consuming tracing to transfer the patterns to the wood, I used my all-in-one printer to copy and print the patterns onto 8½×11" adhesive label sheets (Avery #8165, 800-462-8379, [avery.com](http://avery.com)). Then I just cut out the patterns and stuck them onto the wood. Quick and clean!

—George Mons, Bluffdale, Utah



## Micro-adjust with masking tape

When you need a dado that is slightly wider than an available router bit, build up several layers of 2" masking tape strips on the edge of your router base. You can micro-adjust a test cut by adding or subtracting layers of masking tape, taking care to place the tape flush with the bottom of the router base.

Make an initial cut with an untaped edge of your router base against the straightedge. Then, rotate the router so the tape runs against the straightedge, and cut in the opposite direction for the second cut. The tape pushes the bit outward and widens the dado ever-so-slightly.

—Charles Thompson, Washington, Iowa

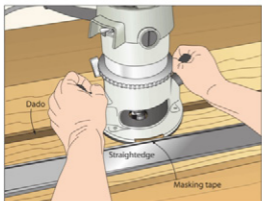

## Mitersaw safety by the wire

Small workpieces cut on the mitersaw can be sucked into the spinning blade, creating a hazard to the operator and the equipment. The device I came up with serves as both a hold-down and an adjustable stop. I simply bent a piece of a coat hanger, as shown below, and attached it to a 1x2x12" scrapwood stop.

—Darwin Peacock, Warner Robins, Ga.

continued on page 10

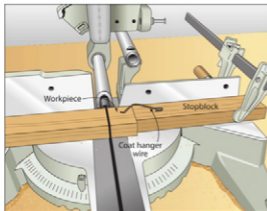

"I'm so happy that Oneida invented the Mini-Gorilla." H. Kalani

"I am amazed how much suction the Mini Gorilla has and how much time it takes to find just a small amount of very fine dust in the pleated filter. The cyclone really separates the dust. There is no longer fine dust covering everything in the shop, and I feel better knowing I'm not breathing that dust. Shop cleanup is now actually fun. Thanks for the amazing dust collector!"

R. Conli March 09



Invented and made in the USA. Built to last a lifetime.

A unique cyclonic Dust Collector with ultra-high efficiency separation.

Separates even the finest sanding dust!

No more clogged filters!

Complete Ductwork & Shop Plan Design Packages



Solving Your Dust Problems Since 1993

Call Today for FREE Catalog!

1.800.732.4065

Order Online!

www.oneida-air.com



## Shop Tips

### Shop-made panel clamps

Because I do a lot of frame-and-panel door glue-ups, my horizontal space quickly gets taken over by clamped-up boards. I can't afford pricey store-bought stackable clamping systems, so I came up with my own version made from hard maple because of its strength. Here's how I do it:

I cut all the parts to size, pre-drill, then attach the top and bottom to the two ends. I glue and clamp one of the

rails in place. Then, I combine the threaded rod, clamping block, coupler, nuts, and clamp assembly, before gluing on the second rail. Finally, I apply paste wax or masking tape to the rails to protect them from glue squeeze-out.

To use the stackable clamps, I can either screw two clamps to a piece of plywood (as shown), or clamp them down to my workbench, making sure they are square and parallel with each other. I assemble a glue-up in the

clamps and use a socket-equipped cordless drill to quickly tighten down the clamping block. Then I finish tightening by hand with a socket set.

I can stack the next set of clamps on top of the first and bolt them together with  $1/8$ "x20 bolts through the end holes. I'm limited only by the number of clamps I build.

—Jerry Schneider, Holland, N.Y.

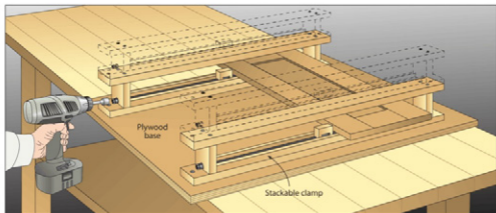
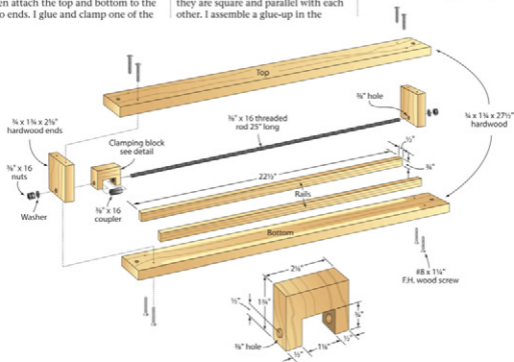



## Avoiding nail blowout: straight to the point

I read with interest the answer you gave about avoiding blowout with pneumatic nail guns in the November 2007 issue of *WOOD* (issue 180, page 92). In my experience, whether it's grain or knots that deflect the nail, a little knowledge about the nail you're using is key. Use the tricks shown to guide the nail's deflection and avoid blowouts. ↗

—David Schmidt, Medford, Ore.



### PNEUMATIC BRAD NAIL

Nail points are clipped side to side so nail will generally deflect side to side.

Hold nail gun perpendicular with board edge.



### PNEUMATIC FINISH NAIL

Nail points are clipped front to back so nail will generally deflect front to back.

Hold nail gun parallel with board edge.

# FEIN MULTIMASTER. The Number One tool for remodeling and renovation.

New QuickIN tool changing



For over 40 years FEIN has been making oscillating tools for professionals and handymen alike, and the FEIN MULTIMASTER is the most versatile. German engineered and manufactured, the high power motor is designed for heavy duty, continuous use and operator comfort. A wide selection of accessories is available for every application. For more information, a free DVD, or to see the complete line of MULTIMASTERS at a dealer near you, call 1-800-441-9878 or visit us at [www.feinus.com](http://www.feinus.com).



# Sounding Board

Our bulletin board for letters, comments, and timely updates

## It's two ... two ... two doors in one!

When designing the door connecting the sunroom and living room in the house he's building for his family, Rick Musselman had a problem: He wanted sweeping "organic" curves on the living-room side and a more traditional paneled look on the sunroom side. He settled on both. Rick's ingenious solution won him a trip to Italy from Freud in the WOOD® Magazine Interior Door Contest.

To match the different trim in the connected rooms, the shop-teacher-cum-school-administrator designed the door as two distinct halves. He constructed the living-room side of the door (far right) from cherry and maple, then enhanced the organic look with chip-carved vines and leaves. The sunroom side (near right) is constructed of pine, and the two halves are pinned together with walnut pegs and butterfly keys (below left).

The split design serves function as well as form. Because each half is 1/2" thick, Rick used common router bits he already had in his home shop.

For submitting the winning entry, Rick will take his daughter Erika on a four-day, three-night trip for two to Venice. They will be treated to a boat tour of the city as well as a tour of Freud's headquarters in Udine, Italy, by President and CEO of Freud America, Russell Kohl.

An educator to the core, Rick is excited to win the contest, but he is more excited by the prospect that his design might inspire a younger generation of woodworkers. Good work, Rick!

See more of the exceptional entries in Editor-in-Chief Bill Krier's blog post at [woodmagazine.com/doorblog](http://woodmagazine.com/doorblog).



## HOW TO REACH US

### ■ For woodworking advice:

Post your woodworking questions (joinery, finishing, tools, turning, general woodworking, etc.) on one of 16 online forums at [woodmagazine.com/forums](http://woodmagazine.com/forums).

### ■ To contact our editors:

Send your comments via e-mail to [woodmail@woodmagazine.com](mailto:woodmail@woodmagazine.com), or write to WOOD magazine, 1716 Locust St., LS-221, Des Moines, IA 50309.

### ■ Subscription assistance:

To notify us of an address change or to get help with your subscription, visit [woodmagazine.com/service](http://woodmagazine.com/service). Or write to WOOD magazine, P.O. Box 37439, Boone, IA 50037-0439. Please enclose your address label from a recent magazine issue.

### ■ To find past articles:

See our index at [woodmagazine.com/index](http://woodmagazine.com/index).

### ■ To order past issues and articles:

Order past issues of WOOD magazine, our special issues, or downloadable articles from issue 100 to present: Visit our online store at [woodmagazine.com/store](http://woodmagazine.com/store). Some issues are sold out.

### ■ Updates to previously published projects:

For an up-to-date listing of changes in dimensions and buying guide sources from issue 1 through today, go to [woodmagazine.com/editorial](http://woodmagazine.com/editorial).

## Ask WOOD

Answers to your questions from letters, e-mails, and WOOD Online

### Are wooden toys illegal?

**Q:** I've heard that a new law is going to require me to test all the toys I make for my grandchildren to ensure that they're lead-free. I can't afford that. What can you tell me about the Consumer Product Safety Improvement Act?

—Howard Acheson, Southport, N.C.

**A:** There's no need to worry about the toys that you make for your family, Howard. However, if you sell toys or other products intended for kids under 13, you might want to take a closer look at the Consumer Product Safety Improvement Act (CPSIA).

Passed by Congress in reaction to lead-laden toys imported from China, the CPSIA requires manufacturers to test and certify that any products intended for children aged 12 and under meet the federal content requirements for lead and phthalates (a chemical used to soften plastics). Costs for the third-party laboratory testing can range from hundreds to thousands of dollars which has small manufacturers calling for fast reform before they are forced to close their doors.

The Consumer Product Safety Commission (CPSC) has been charged with instituting the procedures necessary for compliance. Flooded with questions and concerns about the new law, the CPSC issued a one year stay of enforcement, pushing the deadline back to February 10, 2010, to allow time for clarification of the rules. The law, which initially passed with ease now has Congress squaring off for a battle with several members calling for the resignation of CPSC Acting Chairman Nancy Nord and others drafting legislation to reform the CPSIA. It's too early to predict the outcome for small toymakers, but keep an eye on the CPSC Web site, [cpsc.gov](http://cpsc.gov), for updates.

### Hidden fees for hidden metals

**Q:** The old maple tree that fell in my backyard is just too good for firewood, but all the sawyers I've called seem reluctant to come mill it for me. They quote additional charges in the event of blade breakage. Should I have to pay for their equipment?

—Jimmy Feeling, Riverdale, N.J.

**A:** A broken-blade fee is fairly common for sawyers operating portable mills, Jimmy. Especially when milling "urban" trees, which considerably raise the odds of hitting embedded metal.

Did the maple ever hold a treehouse? Has anyone ever nailed a clothesline to it? Did it live along a fence line where it absorbed barbed wire? These questions are often impossible to answer because trees large enough to hold useful lumber are also old enough to pre-date their current owners. A one-tree job probably doesn't earn the sawyer enough to risk the expense of a seriously damaged blade, so you end up absorbing the cost.

## HAVE A QUESTION?

For an answer to your woodworking question, write to ASK WOOD, 1716 Locust St., L5-221, Des Moines, IA 50309-3023 or e-mail us at [askwood@woodmagazine.com](mailto:askwood@woodmagazine.com). For immediate feedback from your fellow woodworkers, post your questions on one of our woodworking forums at [woodmagazine.com/forums](http://woodmagazine.com/forums)



We discovered this .38 bullet embedded in a piece of "urban" walnut when cutting the wood down to size on the tablesaw.

If you take the plunge and hire a sawyer anyway, spring for a handheld metal detector and thoroughly inspect the lumber before and during milling to prevent damage to your own blades or yourself after you start working the wood in your shop.

*continued on page 16*

## Ask WOOD

### Spalted maple: It's what's for dinner

**Q** I'm going to make a couple of cutting boards for family members. Is it safe to use spalted maple where food will be prepared?

—Scott Fleming, Barrie, Ont.

**A** Great question, Scott. The dark lines prized in spalted wood are caused by white rot fungus. What the fungus adds in beauty, however, it takes away in hardness, leaving behind soft, punky areas. So right away we'd advise against using it for cutting boards.

What about for kitchen items, such as spoons, bowls, and platters? Because sawdust from spalted wood has been known to cause severe respiratory or skin reactions, many woodworkers know to take extra precautions, such as supplementing a dust-collection system with a properly fitted dust mask, when working with it.

But does the danger carry over into contact with food items where particles from the wood could be ingested? According to Tom Harrington, professor



Random black lines make spalted wood attractive, but can leave soft zones unsuitable for cutting boards.

of plant pathology at Iowa State University, the white rot fungus, *Hyphoxylon deusta*, that most commonly causes spalling is not toxic. The fungus lives on the outside of the tree and sends tendrils called *hyphae* into the wood to break down the plant and gather nourishment. To protect themselves and their rotting food source, these tendrils produce a protein coating

that creates the black lines in the wood and likely causes the allergic reaction and irritation when it becomes airborne and lodges in your lungs.

Once your wood bowl is complete, however, the danger from airborne protein subsides. "If you ingest it, it's just going to get digested like all the other proteins that you eat," says Harrington.

## Of course size matters. That's why we make so many.

We've got one in your size... and 278 others just in case. At GRK we think everybody is entitled to ÜberGrade.™ Whether your job deals with wood, metal, concrete or vinyl, GRK makes an ÜberGrade™ fastener that enables you to get the job done right... the first time around.



THUNDER BAY, ONTARIO, CANADA  
800/263-0463 - GRKFASTENERS.COM



## Beveled bottoms for oversized tabletops

**Q** I've glued up a large tabletop and I want to cut bevels on the underside to give it thinner edges and a more delicate look. Because of the size and weight, I don't think I can manage it safely on my tablesaw or router table. Can you help?

—John Gill, Tyler, Texas

**A** Start by constructing an auxiliary router base with a fence mounted to one edge, as shown at right, John. Then, cut three rails of  $\frac{1}{2}$ " MDF slightly longer than the longest dimension of your tabletop. The jig will ride on these rails.

Using double-faced tape, attach one rail to the edge of your workbench and slide the table against it, as shown below. Tape the other two rails together and attach the stacked rails to the tabletop about 6" from its edge. (You can alter the angle of the bevel by changing this distance.)

With a straight or spiral bit mounted in the router, make a pass along one end of the tabletop. (Starting with the end-grain reduces tearout on the edges.) Double-face-tape a  $\frac{1}{4}$ " spacer to the jig's fence and make another pass. Continue the step-and-repeat process, adding spacers and making passes, until the bevel is completed. The bit will nibble away some of the bench-mounted rail on the last pass. Then, rotate the table, remove the spacers from the jig, and repeat for the opposite end and then the edges. Finally, sand the bevel smooth with a sanding block or your random-orbit sander. 🍷

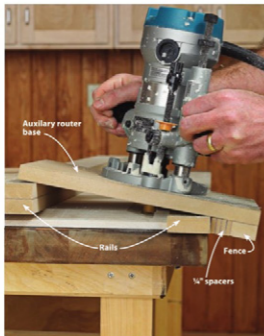

As you add spacers to the jig, the bit cuts more of the bevel, gradually and safely nibbling away the wood.

## Picture an M-412 in Your Shop.

### BAKER M-412 FEATURES:

- Plane up to 11 $\frac{1}{2}$ " wide by 9" tall
- Four-side planing and moulding of material measuring as large as 10 $\frac{1}{4}$ "x4"
- 7,000 RPM spindle speed
- Each spindle is powered by its own motor
- 11-52 FPM variable feed speed
- See-through top guard for viewing cutterheads in action
- Compact machine dimensions: 54"x42 $\frac{1}{2}$ "x47 $\frac{1}{2}$ "

The Model  
M-412 Planer-  
Moulder

A WIDE VARIETY  
OF PROFILE  
KNIVES TO  
CHOOSE FROM!

Good,  
Low Price!  
Call today!

(800) 548-6914 [www.logtolumber.com](http://www.logtolumber.com)



**Peachtree Woodworking Supply Inc.**

"Your One Stop Supply Shop"®

Find the brand names you're looking for at

**ptreusa.com**

Over 5000 woodworking items.  
Shop Online 24 Hours a Day!

Clamps, Sawblades, Router Bits, Abrasives, Books, and More.



Peachtree Woodworking Supply Inc.™  
6484 Jimmy Carter Blvd, Norcross GA, 30071  
Call Toll Free: 1-888-512-9069

# How to Coil a Bandsaw Blade

Quickly and safely condense your blades for convenient storage.



Watch this technique in action at [woodmagazine.com/videos](http://woodmagazine.com/videos)



Hold the blade in your gloved hand, as shown, with the teeth facing away from you. Use a foot to hold the blade to the floor. If you have a concrete floor, place cardboard underfoot to protect the teeth.



In one motion, push the blade down as you twist your hand a half-turn...



...then continue pushing down as you turn your hand another half-turn.



Gather together the three loops with your free hand and hold tightly.



Secure the blade in coiled form using a binder clip or masking tape.

## Uncoiling a blade: Spring forward, not back



1

After removing the clip or masking tape, hold one outside blade coil in each hand with the teeth pointed away from you, and slowly spread them apart. Keep your hands low to protect your face from the blade.



2

Extend your arms away from your body and spread your hands apart as you continue to uncoil the blade. As the coils straighten out, the blade will spring into one big loop, so don't be startled.

woodmagazine.com

19

## Breathe Easier with a One Stop Dust Collection Solution

With 20 years experience and a superior product line, the experts at Penn State Industries will provide you effective solutions for a cleaner shop.



**BEST IN CLASS**  
Cyclone Filtration  
400-700 sq. ft.  
at 1/2-micron capturing  
99.9% of particles.

### TEMPEST™ S-series Cyclones

- ▲ 2.5HP - 1450CFM - \$995
- ▲ 3.5HP - 1700CFM - \$1125
- ▲ 5.0HP - 1800CFM - \$1395

### Premium Ductwork

- ▲ Pipe for maximum airflow
- ▲ Fittings and hoods for most applications

### Ductwork Planning Service

- ▲ An accurate layout of your shop to save you hours of planning

### More Collection Solutions

- ▲ High performance bag-style collectors, air cleaners and portable collectors ideal for any size home shop

**2 GREAT WAYS TO SAVE**

**FREE DUCTWORK PLAN**



**& \$100 OFF**

S-series TEMPEST™ cyclones.

Call for details and mention code: WOOD2.

Offer expires 8/1/09

Call Bill for your free consultation at 1-800-377-7297 x16 to help you plan the best solution for your shop or CNC application.

**Penn State Industries**

1-800-377-7297 • [www.pennstateind.com/nodustwm](http://www.pennstateind.com/nodustwm)

## Bright-Idea Candleholder



Combine salvaged bits of exotic wood with leftover hardwood scraps to give this votive candleholder a special glow.

The legs require so little wood, you can splurge on exotics such as the wenge accenting the cherry frame above. Or go with a single wood, such as the mahogany one above right.

### One blank yields six parts

1 From  $\frac{1}{2}$ " stock, cut a  $4\frac{1}{2} \times 16\frac{1}{2}$ " blank for the top front and back (A), top ends (B), and top trim (C) in this order: From each end of the blank [Drawing 1], crosscut one top trim to length [Materials List, page 21]. Then rip the top front and back from opposite edges of the blank. From each blank end, cut the top ends. Use marks on the top surface, as shown below, to organize parts as they came from the blank.

2 Glue the front and back (A) to the ends (B) [Drawing 2]. After the glue dries, rout  $\frac{1}{8}$ " round-overs along the undersides of the assembly ends (A,B).

### CUT SIX PARTS FROM ONE BLANK



Parts organized in their original order create a frame with an unbroken grain pattern.

### 1 BLANK-CUTTING LAYOUT

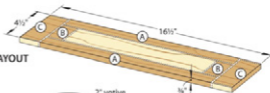

### 2 EXPLODED VIEW

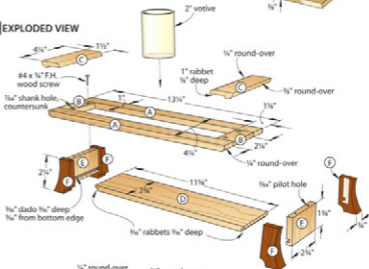

### 2a TOP TRIM SECTION VIEW





**3** Cut the top trim (C) to the same width as the top assembly (A/B) width. Refer to the **Shop Tip** right to rout rabbets and round-overs on the undersides [Drawing 2a]. Sand the top assembly and top trim to 220 grit.

### Assemble the base

**1** Cut the base (D) and base sides (E). Then machine  $\frac{1}{8}$ " rabbets  $\frac{1}{8}$ " deep on the ends of the base and mating grooves on the base sides [Drawing 2]. Sand the base and base sides to 220 grit; then glue the sides to the base and check for square.

**2** Center the top assembly (A/B) on the base assembly (D/E), and clamp together. Drill countersunk shank holes in the top ends (B), and pilot holes in the sides (E), and screw them together.

**3** Glue and clamp the top trim (C) to the top assembly (A/B) [Drawing 2].  
**4** Make four copies of the leg (F) front and side patterns from the **WOOD Patterns** insert, and use spray adhesive to attach them to a  $\frac{3}{8}$ " $\times$ " $\frac{1}{8}$ " blank. Bandsaw or scrollsaw the legs to shape, and sand the edges to 220 grit.

**5** Make tapers on the legs (F) to create two left and two right legs. Saw just outside the taper mark, and sand to the line up to 220 grit.

**6** Glue and clamp the legs (F) centered to the base sides (E) [Drawing 2]. Sand where needed to 220 grit, and apply a finish. (We used three coats of satin polyurethane, sanding with 320-grit sandpaper between coats.)

Written by **Bob Wilson** with **Kevin Boyle**  
Illustrations: **Roxanne LeMoine, Lorna Johnson**

### Materials List

Part	FINISHED SIZE				Matd.	Qty.
	T	W	L	H		
A* top front/back	$\frac{3}{8}$ "	1"	13 $\frac{1}{4}$ "	M	2	
B* top ends	$\frac{3}{8}$ "	2 $\frac{1}{4}$ "	1 $\frac{1}{2}$ "	M	2	
C* top trim	$\frac{3}{8}$ "	4 $\frac{1}{2}$ "	1 $\frac{1}{2}$ "	M	2	
D base	$\frac{3}{8}$ "	2 $\frac{1}{4}$ "	11 $\frac{1}{4}$ "	M	1	
E base sides	$\frac{3}{8}$ "	2 $\frac{1}{4}$ "	11 $\frac{1}{4}$ "	M	2	
F* legs	$\frac{3}{8}$ "	1 $\frac{1}{2}$ "	2 $\frac{1}{4}$ "	RH	4	

\*Parts initially cut oversized. See the instructions.

**Materials key:** M—maple, RH—red heart.

**Supplies:** #4 $\times$ " flathead wood screws, 2" sockets (S) available at craft and gift stores.

**Bits:**  $\frac{1}{8}$ " round-over bit,  $\frac{1}{4}$ " round-over bit, rabbeting bit.

### SHOP TIP

#### Route small parts safely

Double your safety precautions when routing small parts. In a  $\frac{1}{4}$ "-thick sheet of plywood or MDF, drill a hole slightly larger than your router-bit diameter. Center the bit in the hole, and attach the sheet to your router table with double-faced tape for a near-zero-clearance support. Then clamp parts between the jaws of a handscrew placed flat on the sheet to keep fingers well clear of the bit.



# Woodturning Passion Within Your Reach

Pen Kits, Blanks and Turning Projects

Learn more!  
**FREE** Pen Making  
Instructional DVD  
#0V0

Baracuda<sup>2</sup>™ Lathe Chuck

Only  
**\$179.<sup>00</sup>**  
for Complete  
12-piece System  
#C3C3000C

## Get More For Your Money at Penn State Industries

High-performance, expertly designed woodturning products shouldn't cost you a fortune. With our precision engineered PSI Woodworking Products, you'll get best-in-class price/performance results. Plus you'll find the selection and support you deserve with over 2000 products and 25 years of woodworking expertise.

**Penn State Industries. Turn here to pursue your passion.**

TurncrafterPro™  
Variable Speed Midi Lathe

Small,  
Powerful and  
Only **\$279.<sup>00</sup>**  
#TLPH015

Call or go online for a FREE catalog and FREE Pen Making DVD

# Penn State Industries

1-800-377-7297 • www.pennstateind.com

## Fixing **Workshop Goofs**

# Make Router Burn Marks Disappear

Don't let router burns become a black mark against your skills. Eliminate them as quickly as they appeared.

**Y**ou thought you took every burn-proofing precaution. The wood thought otherwise. And judging by the scorch marks on that freshly routed edge, you lost. The only thing worse would be repeating your mistake, so let's figure out what went wrong before we fix the damage.

### Care beats repair

First, check for the usual suspects:

**1 Too much speed.** Fast-turning large bits generate wood-searing heat. Back off the speed control to suit your bit according to these guidelines:

Bit Diameter	Maximum RPM
<1"	24,000
1 to <1 1/4"	18,000
1 1/4" to <2 1/4"	16,000
2 1/4" to 3 1/4"	12,000

**2 Heavy passes.** Take off no more than 1/8" of material with each pass—less on the final one.

**3 Slo-o-o-ow pace.** To avoid heat build-up, feed stock as quickly as possible without leaving chatter marks.

**4 Dull bits.** Replace or resharpen bits that have lost their edge.

### This time for sure

Once you've identified the cause, make the symptoms—burn marks—go away. If they're only light scorches, as shown *bottom left*, first try sanding them away starting with 100-grit abrasives up through 180 grit, or 220 grit if you'll add stain later.

For dark burn marks, rout a fresh profile that removes a thin layer and the burn marks along with it. First, using a hand plane, remove one or two

curls from each edge that will ride along a router table fence or bit bearing, as shown *bottom center*. If you don't have a hand plane, you can, instead, make a light shaving cut on your tablesaw, as shown *above*.

If you're using a bit with no bearing on a router table and you can fudge the part size a hair smaller, move the fence back the thickness of a piece of paper, as shown *bottom right*. To do this, clamp stop blocks to the router table tight against the fence. Loosen and move the fence back enough to insert a piece of paper between the block and fence. Then snug the fence tight against the paper and stop blocks.

Now remove the blocks, and rerout the part at a faster feed rate. This will remove the burn marks with only minimal change in the part size. 🌲



#### SAND AWAY LIGHT MARKS



Profile sanding blocks help you remove light scorch marks, but you can get equally good results using only your fingers.

#### PLANE OFF A THIN STRIP



A block plane tuned to make shavings thin enough to see through removes enough material in two passes to rout away burns.

#### MAKE PAPER-THIN ADJUSTMENTS



Backing off the fence just a hair and, if necessary, nudging the bit height up the same distance will erase these burn marks.

# Shelf-Pin Drilling Jig

A foolproof accessory for perfectly positioned holes.

**T**he challenge with drilling shelf-pin holes: aligning them perfectly so the shelf rests level and doesn't rock. Thanks to a bit of inexpensive hardware, this simple jig gives you a spot-on start for each column of holes, then automatically positions the remaining holes by registering off the last one drilled.

Assemble the jig from scrap stock as shown in the drawing. Lay out the centerpoints for the three evenly spaced holes. The outside holes must be equal distances from the ends of the body. Center the middle hole on the length of the body. Extend a line that passes through all three centerpoints onto each end of the jig to help align the jig when using it. Using brad-point bits in your drill press, carefully drill the holes. Then press an insert and bushing [see **Source**] into the center hole to prevent wear from repeated drilling. Find a  $\frac{1}{4}$ " bolt at least 1' long, and the jig is ready.

When laying out the shelf-pin holes on the project, draw a centerline for each column of holes, as shown in the photo. The distance of the shelf-pin holes from the edge of the panel is

Find more shop jig plans at:  
[woodmagazine.com/freplans](http://woodmagazine.com/freplans)



determined by the fence. As built, the jig places holes 3" from the edge. If a project requires holes closer to the edge, simply tape a spacer to the inside of the fence as shown above. Secure a stop collar to the bit, or wrap tape around it to prevent drilling through the panel, and you're ready to go.

The first hole in each column must align exactly with its three mates, or else every set of holes will be misaligned, and a shelf will teeter no matter where it's placed. But don't worry—the jig gets all four columns off to a perfect start. For the bookcase on page 34, we aligned the bottom edge of the jig with the bottom edge of each panel, then drilled the first hole. To start the holes farther up a panel, cut a spacer of appropriate thickness and place it below the jig.

Hold or clamp the jig to the panel, place the drill bit in the bushing, and drill the first hole. Then slide the jig up, drop the bolt through the jig into the hole just drilled in the panel, and drill the second hole. Repeat this process to drill the remaining holes. To drill holes from the opposite edge of the panel, rotate the jig end for end. 🍷

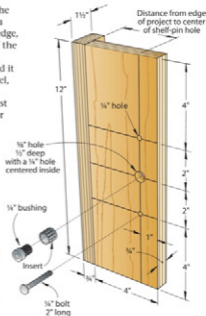

**Source**  
Insert, no. Z5K62.20, \$2.50;  $\frac{1}{4}$ " bushing, no. Z5K62.04, \$2.50; Lee Valley, 800-871-8158, [leevalley.com](http://leevalley.com)

# Cut Big-Time Joints with a Small-Time Saw



If your circular saw leaves the shelf only to trim deck boards or knock down sheets of plywood to rough size, you're underutilizing it. You can also use it as a joinery tool for parts too unwieldy to dado on a tablesaw, such as the picnic table parts on page 60.

Start by preparing a saw for joinery work. For cleaner cuts, set aside that 24-tooth rough-duty blade in favor of a 40-tooth regular-kerf blade. Then set the blade 90° to the base plate.

Next build the cutting guide shown below. Measure from the left edge of the saw base to the blade (when viewed from the top), add 1/4", and glue the fence that distance from the right edge of the guide. Glue a cleat 90° to the fence on the underside of the guide.

To prepare the guide, place it on a piece of scrap clamped to your workbench with the right edge overhanging the bench. With the left edge of the circular saw base pressed firmly against the fence, cut off the surplus 1/4". Now you're ready to start cutting joints.

### Remove waste quickly using kerfs

If you have multiple workpieces to be dadoed the same, clamp them together to support the guide. Mark where the dado will start, then use the mating workpiece to mark the end of the cut.

Next, adjust the saw blade to cut the dado depth plus 1/2" (the thickness of the guide base). Here we're cutting a

dado as deep as the mating workpiece thickness. Test cut a scrap piece to confirm the depth.

To begin cutting the dado, slide the guide edge to the left-hand mark [Photo A]. (Clamp the jig to the workpieces, if necessary.) Place the saw base against the fence and make your first outside cut. Then slide the guide toward the other cut line until the right jig base edge is a blade-width distance from the right-hand mark, and make the second outside cut [Photo B].

With the joint defined, now cut kerfs roughly every 1/4" to 1/8" apart between the outside kerfs [Photo C]. You can make the kerfs slightly farther apart for softwoods, such as this cedar, or closer for hardwoods, such as white oak.

*continued on page 28*

### 90° CUTTING GUIDE FOR CIRCULAR SAWS

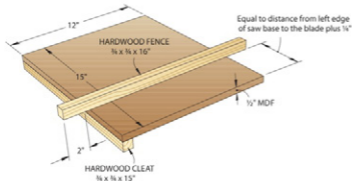

This guide handles most joinery cuts, but can be downsized for smaller jobs. If you're making extra-deep cuts, reduce the fence height from 1 1/2" to 1" to accommodate the saw motor.

### SLIDE THE JIG INTO POSITION



After trimming the jig to size, the right edge indicates precisely where your blade will cut. Slide the edge up to your left outside cut line.

## Just-Right Joinery

### DEFINE THE DADO WITH KERFS



**B** The saw kerf should remove the left outside cut line. Allow for the blade width when sawing at the right outside cut line.

### HOG OUT WASTE WITH YOUR SAW



**C** Slide the jig along as you saw away waste to keep cuts at a uniform depth and provide a stable surface for your saw.

### GIVE YOUR JOINT A BREAK



**D** A nudge with your fingertips breaks off the waste between the kerfs. Most should split close to the bottoms of the kerfs.

### Clean up the cuts

After the final kerf cut, use a hammer or your fingertips [Photo D] to break the waste off as close as possible to the bottom of the kerf. Clean up the leftover waste with a chisel at least 1" wide. Place the chisel bevel-side up on the smoothest portion of the dado and gently shave off the waste [Photo E]. You'll still have score lines from the alternating-bevel teeth of the blade, but the surface between the marks should be smooth.

The mating workpiece should fit snugly into the dado without excessive force [Photo F]. If it's too tight, shave one side of the dado with your chisel or sand it using a scrap block with 100-grit abrasive on one edge. Then glue and assemble the joint, reinforcing it with fasteners as needed. 📌

### TIME FOR A CLOSE SHAVE



**E** Shave away waste with your chisel, working from the outside toward the middle to avoid possible tear-out.

### FITS LIKE A GLOVE



**F** You may not achieve the perfection that's possible with a router or tablesaw, but a circular saw can cut tight-fitting joints.

## SHOP TIP

### Use the same jig and technique to cut angles

Not all half-laps or notches require a 90° cut, but you can manage any joint angle quickly and easily with a modified version of the 90° jig. Instead of attaching the fence at 90°, angle and center it on the jig base. Depending on the angle, you may need to extend the fence at the front of the jig to help align the saw base. Use a sliding bevel and protractor to set the fence angle. To give the saw a firm footing as you start the cut, move the underside cleat in 1" from the edge so the jig base overhangs the workpiece edge. Then make the cuts between your lines as you would for a 90° joint cut.



# Wise Buys

Our Experts Test

# Coping Sleds

**MLCS, #9497, \$35**

### Editor test-drive:

For probably 95 percent of the work you'll do with a coping sled, this bare-bones phenolic model is all you'll ever need. Its abrasive-coated base and single, adjustable clamp securely hold stock from  $\frac{1}{2}$ " to  $1\frac{1}{8}$ " thick. If you need to make coped cuts on stock wider than  $3\frac{1}{2}$ " or longer than 18", you should opt for the larger MLCS sled (#9546, \$65). You can buy replacement backer blocks for each model, but it's easy to make your own from scrap wood.



To learn more:

800-533-9298; mlcswoodworking.com

—Tested by Bob Hunter,  
Tools & Techniques Editor



### Why buy?

A fundamental element of furniture and cabinet doors, cope-and-stick joints must fit precisely to ensure square, gap-free doors. To make the job easier and safer, a coping sled holds the frame rails securely and squarely as you rout the profile across the end grain using your router table or shaper. The models in this review slide along the table's fence, which is set flush with the cutter's bearing. These prove easier to use than sleds that run in a miter slot. If you'd rather make your own sled, you'll find plans for one on page 32.

**ROCKLER, #28595, \$60**

### Editor test-drive:

For \$25 more than the MLCS sled, Rockler offers a larger phenolic base with nearly double the width capacity, and a front guide block to sandwich the workpiece against the wood backer block. You also get a larger clamp pad and a front-mounted knob for two-handed control. One knock: During assembly, I had to deepen the countersunk holes for the handle to fully seat the screws and prevent scratching my router table.



To learn more:

800-279-4441; rockler.com

—Tested by Randy Zimmerman  
Randy builds custom furniture and cabinets



**EAGLE AMERICA, #2100, \$80**

### Editor test-drive:

Eagle America makes three coping sleds that work similarly, but this rigid plastic model is the one to buy. Its dual-pad adjustable clamp provides better workpiece holding power, and there's a front guide block for extra support and two easy-to-grip handles. What I like best about this nearly 16"-long sled: It glides smoothly over the insert plate—which always seems to vibrate slightly out of level—in my router table, producing perfect coped ends.



To learn more:

800-872-2511; eagleamerica.com

—Tested by Craig Rueggeger,  
Multimedia Editor



**INFINITY, #COP-100, \$150**

### Editor test-drive:

This sleek aluminum sled is the Lexus of coping sleds. Its three clamps can adjust to hold the workpiece and wood backer block, which makes changing backer blocks quick and easy. The large, comfortable foam-covered rear handle dampens vibration better than the others. A clear plastic chip shield mounted on posts rides against the fence, providing a  $\frac{1}{4}$ " offset to keep the aluminum base clear of the bit. However, your fence must be at least  $3\frac{3}{4}$ " tall to engage this shield; if not, you'll need to add a taller auxiliary fence.

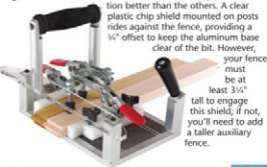

To learn more:

877-872-2487; infinitytools.com

—Tested by Bob Hunter



# Cope-Cutting Sled

Rout rail ends safely and precisely.

**A** rock-solid support system helps you rout rail ends that tightly fit mating stiles. The large base, dado, and hold-downs designed into this sled accomplish just that, while the handle and dowel keep your hands safely away from the spinning bit.

Build the sled by cutting the parts to the sizes noted on the drawing. Make several extra sacrificial backer strips. The backers create zero-clearance supports for cleaner cuts, and can be easily replaced after becoming too chewed up.

Glue two pieces of  $\frac{1}{8} \times 7\frac{1}{2} \times 17$ " plywood together face-to-face for the base. Cut a  $\frac{1}{4}$ "-deep dado 4" wide in the 1"-thick base. Use the full-size pattern on the *WOOD Patterns* insert to create the handle, and rout  $\frac{1}{4}$ " round-overs along the handle edges except for the bottom. Screw the handle, dowel, and toggle clamps to the base, making sure the screwheads are countersunk so they won't rub against the router top.

To cope the end of a rail using the sled, raise the bit  $\frac{1}{4}$ " higher than if you were cutting the rail directly on the router tabletop. Clamp a scrap piece of stock the same thickness as your rails firmly against the router-table fence and backer strip with the toggle clamps. Turn on the router, and ease the sled and workpiece into the bit. Slide the sled and test piece backward just after completing the cut in the rail end, where shown in the photo. Doing this prevents destruction of the sled's trailing inside edge. Check the fit of the joint against your previously routed stiles, and adjust the height of the bit as necessary before cutting your rails. 🌲

Project design: Rod Cox, Mt. Pleasant, Iowa

Get more FREE plans at:  
[woodmagazine.com/freplans](http://woodmagazine.com/freplans)

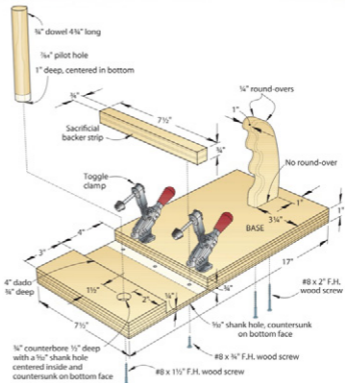
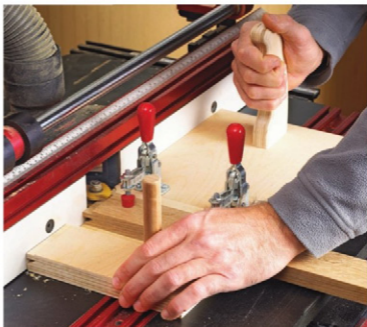

# Glass-Door Bookcase

Classic lines and rounded corners highlight this elegant cabinet.



## PROJECT HIGHLIGHTS

- Overall dimensions: 41 $\frac{1}{2}$ " wide x 16 $\frac{1}{2}$ " deep x 36" high.
- Materials needed:  $\frac{3}{4}$ " and 1 $\frac{1}{2}$ " cherry;  $\frac{1}{4}$ " and  $\frac{3}{8}$ " cherry plywood; single-strength glass.



## HOW TO ROUT MIRRORED STOPPED GROOVES



**A** Clamp a stopblock to the router-table fence  $1\frac{1}{2}$ " from the left edge of the bit. Rout a  $\frac{1}{4}$ " groove in only one blank with this setup.



**B** Reposition the stopblock, and plunge the second blank onto the bit. The blanks end up as mirror images of each other.

## CAULS DIRECT CLAMP PRESSURE



**C** Cauls provide flat surfaces for clamping the front stiles (C). The inside faces of the stiles (C, D) and side panels (A) should be flush.

Once you finish soaking up the handsome look of this project and begin to examine its construction, you'll discover how simple it is to build: Hardwood glued to plywood lends the appearance of frame-and-panel sides without the need for cutting difficult joints. Half-lap joints cut on the tablesaw ease door construction. Mullions adhered to the glass create the look of four-pane divided-light doors without the pain of fussy moldings.

### Start with the side panels

**1** Cut the case side panels (A) to size [Materials List, page 40]. Resaw and plane a  $\frac{3}{8}$ " $\times$ 28" blank to get two  $\frac{1}{4}$ "-thick blanks; then cut the panel trim pieces (B) to length from these blanks [Drawing 1]. **Quick Tip! Stop glue squeeze-out.** Use your tablesaw to cut shallow glue-relief grooves in the back face of the panel trim pieces to trap glue before it squeezes out onto the face of the side panel. Glue the panel trim pieces to the side panels, flush with the top and bottom edges.

**2** To make the front stiles (C) and rear stiles (D), start with  $\frac{1}{2}$ " or  $\frac{3}{4}$ " lumber (or laminate two layers of  $\frac{3}{8}$ " stock). From this material, cut two  $1\frac{1}{2}$ " $\times$ 2 $\frac{1}{2}$ " $\times$ 30 $\frac{1}{2}$ " blanks. Position the tablesaw rip fence  $\frac{1}{2}$ " from the blade, set the blade  $\frac{1}{2}$ " above the tabletop, then cut a kerf in one face of each blank, and in a piece of scrap at least  $\frac{3}{8}$ " thick. Nudge the fence away from the blade, and make another cut in the scrap to widen the groove. Test the fit of the plywood to be used for the back panels (H) in the groove. If needed, adjust the fence, and make another cut to obtain a snug fit; then make a cut to widen the groove in each blank.

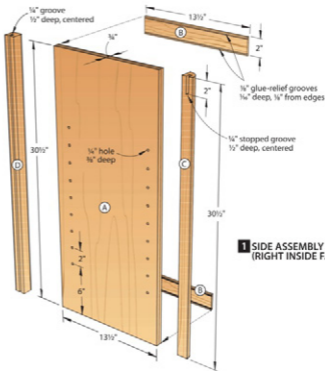

**1** SIDE ASSEMBLY (RIGHT INSIDE FACE)

### 1a STILE DETAIL

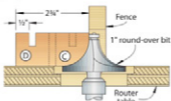

### 1b SIDE DETAIL

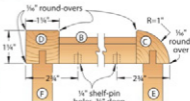

### CUTTING CENTERED STUB TENONS



Make a pass on each face to make a centered tenon. Cut a test tenon on scrap the same thickness as the workpiece to check setups.

### MARK GROOVE POSITION ON RAILS

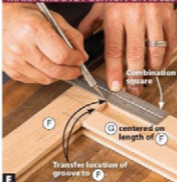

Center the center stile (G) on the back rails (F). Use a square and a crafts knife to transfer the groove location to each back rail.

### SPACERS KEEP IT SQUARE



Cut scrap spacers to fit between the ends of the back rails (F). This prevents clamping pressure from bowing the rails.

## 2 EXPLODED VIEW

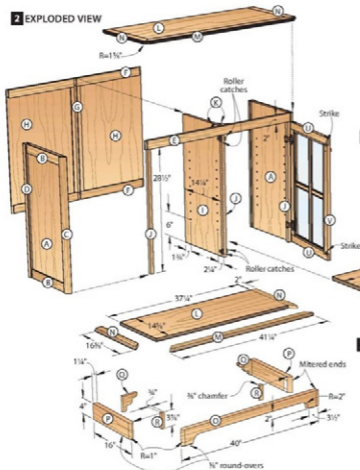

**3** In a table-mounted router, set up a 1" round-over bit, and, in progressively deeper passes, round over the edge of each blank opposite the kerf [Drawing 1a]. Switch to a 1/2" straight bit, and clamp a stopblock to the fence 1 3/4" from the bit [Photo A]. Position the fence 1/2" from the bit, and rout a stopped groove in one

### 2a FRONT RAIL TENON DETAIL

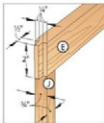

### 2b BASE/TOP CORNER DETAIL

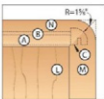

### 2c BASE PANEL DETAIL

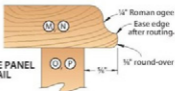

## SQUARE THE CASE WITH BRACES

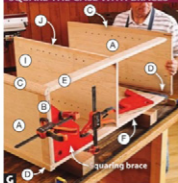

Temporary squaring braces at the top and bottom of each side assembly keep parts square while the glue dries.

## PERFECT-FIT EDGING

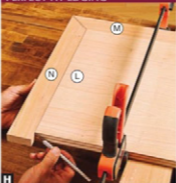

Clamp two mitered edging pieces (M, N) to a top panel (L), and mark their final lengths. Keep all faces flush as you glue them in place.

blank. This blank will be used for the left-side front and rear stiles (C, D).

**4** To complete the blank for the right-side front and rear stiles (C, D), reset the stopblock on the opposite side of the bit [Photo B]. Plunge the second blank onto the spinning bit, keeping the blank tight to the fence and stopblock. Move the blank along the fence to create the stopped groove. Use a chisel to square up the end of each stopped groove.

**5** Rip a 1 $\frac{1}{2}$ "-wide front stile (C) and rear stile (D) from each blank. Rout  $\frac{1}{8}$ " round-overs on the outside edges of the stiles [Drawing 1b]. Sand the pieces to 220 grit, and then glue the stiles to the side panels (A) [Photo C].

## Make a case and back it up

**1** Cut the front rail (E), back rails (F), and center stile (G) to size. Set aside the front rail for the time being. In the same manner as the grooves in the front and rear stiles, cut centered grooves in both edges of the center stile and the inside edges of the back rails to match the thickness of the back panels (H) [Drawing 3a].

**2** Set up a  $\frac{3}{8}$ "-wide stack dado set in your tablesaw. Mount a wood auxiliary fence to the saw's rip fence, and raise the blade into it to leave  $\frac{1}{8}$ " of the blade's width exposed. On each end of the front rail (E), back rails (F), and center stile (G), cut a tenon to fit the groove in the mating pieces [Drawing 2a, Photo D]. **Note:** Check the fit as you go. The front rail may require thicker tenons than the back rail and center stile. Set the front rail aside again.

**3** Remove the auxiliary fence from the tablesaw, and position the rip fence  $1\frac{1}{8}$ " from the dado set. Cut a centered groove in one face of the center stile (G)

to accept the center divider (I). Center the center stile on the length of the back rails (F), and transfer the location of the groove to the rails [Photo E]. Extend the marks onto the edges of the rails, and then cut a dado between the marks [Drawing 3].

**4** Dry-fit the back rails (F) and center stile (G). Cut the back panels (H) to size, and test their fit in the assembly. Sand the rails, stile, and back panels to 220 grit, and then glue up the assembly [Photo F].

**5** Dry-fit the side assemblies (A/B/C/D), front rail (E), and back assembly (F/G/H). Measure between the groove in the center stile (G) and the back of the front rail. Cut the divider (I) to this

width and to finished length. Next, measure from the bottom edge of the front rail to the bottom of the front stiles (C). Cut three front trim pieces (J) to this length [Drawing 2], and set two of them aside. Glue one trim piece to the front edge of the divider, flush at the bottom. After the glue dries, sand the trim flush with the faces of the divider.

**6** Drill the shelf-pin holes using the Quick and Easy Jig shown on page 24. Note that the holes in the divider (I) are set in different distances than the holes in the side panels (A) [Drawings 1b, 2].

**7** Cut the top cleats (K) to shape, guided by a photocopy of the cleat pattern from the WOOD Patterns<sup>®</sup> insert; then begin assembling the case [Photo G]. **Quick Tip! Squaring braces serve as extra hands.** Make larger versions of the top cleats to temporarily hold mating pieces in position during glue-up and to keep the assembly square. Chamfer the inside corner of each brace so they don't get glued in place. Glue one

## 3a JOINERY DETAIL

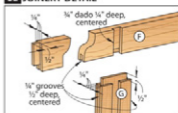

## 3 BACK ASSEMBLY

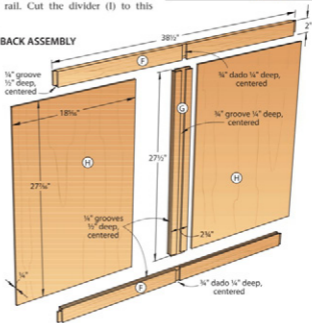



**I** Round the round-overs on the ends of the base pieces (O, P); then mark and cut the miters. The base ends are cut to finished length later.



**J** Center the base front (O) on the length of the bottom assembly and inset  $\frac{1}{8}$ " from the front edge; then glue it in place.



**K** Position the riser blocks to help align the top assembly with the rear stiles (D). A temporary spacer keeps the divider (I) from racking.

side assembly (A/B/C/D) to the back assembly (F/G/H), then add the divider (I/J). Add the front rail (E), then the remaining side assembly. Check the divider for square to the case, then glue and clamp the top cleats in place [Drawing 2]. Glue a front trim (J) to each front stile (C) below the front rail.

### Wrap up a top and bottom

**1** Cut the top and bottom panels (L) to size from  $\frac{3}{4}$ " plywood.

**2** Cut blanks for the front edging (M) and end edging (N) 1" longer than indicated in the Materials List. Miter-cut one end of each edging piece. Clamp a front edging piece and an end edging piece to a panel (L), and mark the final length of the end edging [Photo H]. Also mark the inside edge of the miter at the opposite end of the front edging. Cut both pieces to length. Glue and clamp these two pieces to the panel; then position and mark the remaining end edging, cut it to final length, and glue it in place. Repeat this process for the other panel.

**3** Use a compass to lay out the radius on each front corner of the panel assemblies (L/M/N) [Drawing 2b]. Cut just outside the line with a jigsaw, then sand to the line with a sanding block.

**4** Route a  $\frac{1}{4}$ " roman ogee around the top edge of the bottom panel assembly (L/M/N) and around the bottom edge of the top panel assembly [Drawing 2c]. Switch to a  $\frac{1}{8}$ " round-over bit, and round over the edge of the opposite face of each assembly. Lightly sand the transition between the two profiles to blend them together. Finish-sand both assemblies.

### Build up a base

**1** Machine stock to thickness and width for the base front (O) and base ends (P). Crosscut the base front to finished length, and the base ends 1" over length.

**2** Mount a 1" round-over bit in your router table, and round over both ends of the base front (O) and one end of each base end (P). Then mark the miters on all three pieces, and cut them [Photo I].

**3** Using the base front full-size pattern from the WOOD Patterns® insert, lay out and cut the profile on the base front (O) [Drawing 2]. Sand the edges smooth, and rout  $\frac{1}{8}$ " round-overs on the bottoms of the feet and the bottom edges of the base ends (P). Finish-sand the base pieces to 220 grit.

**4** Turn the bottom assembly (L/M/N) upside down on riser blocks [Photo J]. Glue the base front (O) to the bottom assembly [Drawing 2c].

### SKILL BUILDER

#### Setting up for a perfect half-lap

A flush-fitting half-lap joint begins with setting the dado blade to the proper height. Start with two pieces of scrap the same thickness as your workpieces. Set the dado-blade height to just under half the thickness of the scrap. Using the miter gauge to guide the piece, cut a rabbet in one end of each scrap. With the pieces resting on a flat surface, test how the rabbets fit together. Adjust the blade height until the faces fit flush with no gap between the rabbets.



**5** While the glue dries on the bottom assembly (L-O), position the base ends (P) against the base front (O), and make a mark at the end of the end edging (N). Crosscut along this line to bring the base ends to finished length, and then glue and clamp them in place.

**6** Cut the back cleats (Q) and front cleats (R) to size and shape [Materials List]. (Find a full-size pattern for the back cleats in the WOOD Patterns® insert.) Sand or plane a  $\frac{1}{8}$ " chamfer on the front cleats to provide a flat clamping surface. After the glue has dried on the base, glue and clamp the back and front cleats in place [Drawing 2].

### Add the top and bottom

**1** Raise the carcass off your bench with a riser block under each rear stile (D). Apply glue to the top edges of the side panels (A), front and back rails (E, F), and divider (I). Position the top

## RABBET THE RAILS AND STILES



**L** House the dado blade in an auxiliary rip fence leaving  $\frac{1}{8}$ " exposed. Cut rabbets on the inside edge of each door rail (U) and stile (V).

## SHOP TIP

### Use parts as a dead-on gauge

Use a rail (U) to set up for the different-width half-laps on the rails and the stiles (V). Align one edge of the rail with the blade's outside tooth. Butt the rip fence against the other edge. Use the rail's full width when setting up to cut joints on the rails (left photo). For the stiles, use the just-cut half-lap (right photo).



assembly (L/M/N) so that the edge profile mirrors that of the bottom assembly. Clamp the top assembly in place, flush with the back edges of the rear stiles and centered side-to-side [Photo K]. Glue the bottom assembly (L-R) in place in a similar fashion.

**2** Cut the shelves (S) and shelf trim (T) to size. Glue the trim to the front edge of the shelves with the top edge and ends flush [Drawing 2]. Allow the glue to dry, then sand the shelves and trim to 220 grit.

### Inset doors made easy

**1** Cut  $\frac{3}{8}$ " stock to width for the door rails (U) and door stiles (V) [Drawing 4]. To determine their length, measure the width and height of the door openings. Cut the rails and stiles  $\frac{1}{8}$ " shorter than these dimensions.

**2** Using a  $\frac{3}{8}$ " dado set in the table saw, cut a test half-lap [Skill Builder, opposite]. When the blade is at the proper height, lock it in place.

**3** Cut a  $\frac{3}{8}$ " rabbet on the edge of each door rail (U) and stile (V) [Photo L].

**4** Using a door rail (U) as a gauge, reposition the fence [Shop Tip, above]. With the rabbeted face up, cut half-laps at each end of the door rails (U) only. Use a door rail again to reset the fence [Shop Tip]. Cut half-laps on the ends of the door stiles (V) using this setup with the rabbeted face down.

**5** Glue up the door frames (U, V), clamping at each half-lap. Carefully check the frames for square before the glue sets up.

**6** After the glue dries, screw the hinges to each door [Drawing 4]; then mount the door to the cabinet [Photo M].

**7** Check the fit of the doors in the openings. Plane the doors as needed

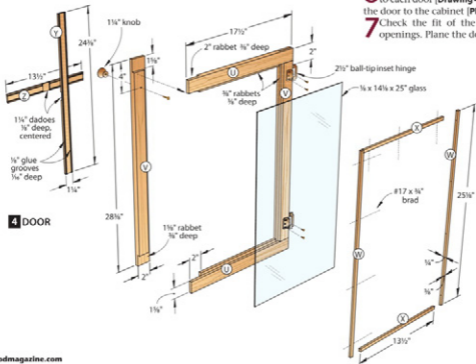

## 4 DOOR

## SPACING IT RIGHT ON THE MONEY



Rest the door on a quarter placed on the bottom assembly. Using a self-centering bit, drill screw holes for the hinges.

to get an even gap on all sides. Install the door catches and knob where shown [Drawings 2, 4].

8 Plane or resaw stock to  $\frac{1}{4}$ " thick for the glass stops (W, X), mullions (Y), and muntins (Z). Cut the vertical glass stops (W) to length to fit in the rabbets in the door stiles (V) [Drawing 4]. Trim the horizontal glass stops (X) to fit in the rabbets in the door rails (U) between the vertical glass stops. Cut the mullions to length to fit between the door rails, and the muntins to fit between the stiles. Make test cuts in  $\frac{1}{4}$ "-thick scrap to check your setup; then create centered half-laps on each mullion and muntin, and plow out glue grooves near each edge.

Remove the hardware, and finish-sand the doors, glass stops, mullions, and muntins up to 220 grit. Apply a finish to the cabinet and door pieces. (We wiped on one coat of Old Masters Dark Mahogany stain, no. 60804, and topped it with three coats of water-based polyurethane, buffing lightly between coats with 320-grit sandpaper.)

## HAMMER IT HOME



Place a piece of cardboard on the glass to protect it while using a tack hammer to drive the brads into the glass stop.

9 After the finish dries, place the glass in each door. Pre-drill holes in the glass stops (W, X) for the brads, and nail the stops in place [Photo N]. Don't use glue so the stops can be removed if the glass should break. Apply a light coat of silicone adhesive to the back face of the mullions (Y) and muntins (Z), and secure them to the glass with painter's tape while the silicone cures. Reattach the hardware, and hang the doors. Now, introduce your prized books and keepsakes to their new home. 🌲

Written by **Craig Rueggesser** with **Jeff Mertz**  
Project Design: **Kevin Boyle**  
Illustrations: **Rosanne LeMoine, Lorna Johnson**

## Cutting Diagram

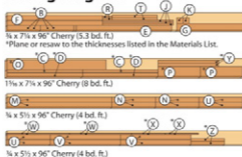

$\frac{1}{4}$  x 48 x 48" Cherry plywood



$\frac{1}{4}$  x 48 x 96" Cherry plywood

## Materials List

Part	FINISHED SIZE			Matl.	Qty.	
	T	W	L			
<b>Case</b>						
A	side panels	$\frac{1}{4}$ "	13 $\frac{1}{2}$ "	30 $\frac{1}{2}$ "	CP	2
B*	panel trim	$\frac{1}{4}$ "	2"	13 $\frac{1}{2}$ "	C	4
C*	front stiles	1 $\frac{1}{2}$ "	1 $\frac{1}{2}$ "	30 $\frac{1}{2}$ "	C	2
D*	rear stiles	1 $\frac{1}{2}$ "	1 $\frac{1}{2}$ "	30 $\frac{1}{2}$ "	C	2
E	front rail	$\frac{1}{4}$ "	2"	38 $\frac{1}{2}$ "	C	1
F	back rails	$\frac{1}{4}$ "	2"	38 $\frac{1}{2}$ "	C	2
G	center stile	$\frac{1}{4}$ "	2 $\frac{1}{2}$ "	27 $\frac{1}{2}$ "	C	1
H	back panels	$\frac{1}{4}$ "	18 $\frac{1}{2}$ "	27 $\frac{1}{2}$ "	CP	2
I	divider	$\frac{1}{4}$ "	14 $\frac{1}{2}$ "	30 $\frac{1}{2}$ "	CP	1
J	front trim	$\frac{1}{4}$ "	$\frac{1}{4}$ "	28 $\frac{1}{2}$ "	C	3
K	top cleats	$\frac{1}{4}$ "	2 $\frac{1}{2}$ "	2 $\frac{1}{2}$ "	C	2
L	top/bottom panels	$\frac{1}{4}$ "	14 $\frac{1}{2}$ "	37 $\frac{1}{2}$ "	CP	2
M*	front edging	$\frac{1}{4}$ "	2"	41 $\frac{1}{2}$ "	C	2
N*	end edging	$\frac{1}{4}$ "	2"	16 $\frac{1}{2}$ "	C	4

Base						
O	front	1 $\frac{1}{2}$ "	4"	40"	C	1
P*	ends	1 $\frac{1}{2}$ "	4"	16"	C	2
Q	back cleats	$\frac{1}{4}$ "	3 $\frac{1}{2}$ "	3 $\frac{1}{2}$ "	CP	2
R	front cleats	$\frac{1}{4}$ "	$\frac{1}{4}$ "	3 $\frac{1}{2}$ "	C	2

Shelves						
S	shelves	$\frac{1}{4}$ "	13"	18 $\frac{1}{2}$ "	CP	2
T	shelf trim	$\frac{1}{4}$ "	1"	18 $\frac{1}{2}$ "	C	2

Doors						
U	rails	$\frac{1}{4}$ "	2"	17 $\frac{1}{2}$ "	C	4
V	stiles	$\frac{1}{4}$ "	2"	28 $\frac{1}{2}$ "	C	4
W	vertical glass stops	$\frac{1}{4}$ "	$\frac{1}{4}$ "	25 $\frac{1}{2}$ "	C	4
X	horizontal glass stops	$\frac{1}{4}$ "	$\frac{1}{4}$ "	13 $\frac{1}{2}$ "	C	4
Y	mullions	$\frac{1}{4}$ "	1 $\frac{1}{2}$ "	24 $\frac{1}{2}$ "	C	2
Z	muntins	$\frac{1}{4}$ "	1 $\frac{1}{2}$ "	13 $\frac{1}{2}$ "	C	2

\*Parts initially cut oversize. See the instructions.

**Materials key:** C—cherry, CP—cherry plywood.  
**Supplies:**  $\frac{1}{4}$ "-14 $\frac{1}{2}$ "-25" single-strength glass (2), silicone adhesive; #17x $\frac{1}{2}$ " wire brads.  
**Blade and router bits:**  $\frac{1}{4}$ " roman ogee,  $\frac{1}{4}$ ",  $\frac{1}{8}$ ", 1" round-ove,  $\frac{1}{4}$ " straight bits stack dado set.

## Source

**Hardware:**  $\frac{1}{4}$ " spoon shelf supports, pack of 20, no. THB0144, \$3.20; antique brass roller catches (4), no. LA1910 AC, \$1.24; 2 $\frac{1}{2}$ " full-wrap inset ball tip hinges (4), no. A031978 ORB, \$2.62; 1 $\frac{1}{2}$ " oil rubbed bronze knobs (2), no. AS3005 ORB, \$1.44; Woodworker's Hardware, 800-383-0130, woodworkershardware.com.

## MORE RESOURCES

### FREE PLAN

Download a plan for the squaring braces at [woodmagazine.com/brace](http://woodmagazine.com/brace)

**HEAD**  
Phillips or Slotted



**SHANK**  
Same diameter  
as the threads

**THREADS**  
Deeper at the tip  
than near  
the shank

**TIP**  
Almost blunt

# Choose the Right Screw for the Job Today's

The days when slotted or Phillips was your only choice ended years ago. Now you've got better everyday screws and problem-solving specialty fasteners.

**I**f you still rely on traditional wood screws to assemble projects, it's time to get the right fasteners for the job: screws that resist breaking, don't eject their driver bits, and require just one shank/pilot hole. To sort through the fasteners available, ask yourself a few questions about the task at hand.

**1 Indoors or outdoors?** Outdoor screws need corrosion resistance. A zinc coating provides minimal rust protection. For pressure-treated lumber, use screws with coatings that withstand corrosive treatment chemicals. For maximum corrosion resistance, choose silicon-bronze or stainless-steel screws.

**2 Exposed or concealed?** If a screw must sit flush with or below the surface, use a countersunk flathead screw. To hide a flathead screw, add a counterbore and cover the screw with a wooden plug. If the screwhead can rest above the surface, use a panhead screw to reduce splitting or pull-through.

**3 What size?** Screw diameters are measured in gauges, mostly from #4 to #14. A #8 screw handles most projects. Use #10–#14 screws for big jobs, such as an arbor, and #6 screws for tabletop projects. Screws should reach at least  $\frac{3}{4}$ " into the bottom part you're fastening and preferably two-thirds the screw length.

*continued on page 42*

**HEAD**  
Phillips/Square Combination,  
Square, or Torx (star)  
for less bit-slippage.



**SHANK**  
Straight down to  
the tip—no shank  
holes needed.

**THREADS**  
Deep along the  
entire length for  
greater grip.

**TIP**  
Sharp, some with  
auger notches  
or serrations for  
easier starting.

**Then...**

**...Now**

## Must-Have Screws

### FLATHEAD

Today's flathead screws use square and Torx/star driver bits instead of just Phillips drives. Most have straight shafts with deep threads, and enough unthreaded shank to help the head pull the top workpiece tight against the lower piece. Some have serrated threads or auger grooves at the tip (detail) to cut through wood fibers around the pilot hole for easier driving.



### PANHEAD

Use panhead, or sheet-metal, screws to attach hold-downs and other jig hardware plus project hardware such as drawer slides. The threads extend up to the head. When joining two pieces of hardwood, you may need an oversize shank hole in the top piece to keep the threads from pushing pieces apart. A flat-top panhead (or "pocket-hole screw," named for its primary use) comes with fine threads for hardwoods or coarse threads for softwoods.



### STAINLESS-STEEL

Stainless steel resists corrosion and discoloration on outdoor projects. Look for "300 series" steel with 18 percent chromium and 8 percent nickel that resists corrosion under normal circumstances. A 316 stainless adds molybdenum for greater protection against salt-air corrosion. An auger point doesn't eliminate the need for pilot holes, but makes driving the screw easier. Some types have colored heads to blend better with deck boards or trim.



## Specialty Screws

### TRADITIONAL WOOD SCREW

The tapered shaft of a traditional wood screw requires drilling one hole for the shank, a smaller pilot hole for the threads, and finally a countersink. Or use a tapered bit, shown at far right, to drill all three at once. Keep these handy for restoring or re-creating antiques. To drive brass screws, drill pilot holes, and cut the wood fibers for the threads by driving and removing a steel screw of the same size. Then insert the brass screw.



### WASHER-HEAD

The wide, flat underside of the washer-head screw disperses force over a larger area than even a panhead screw. Use #10 versions up to 3" long to hang cabinets. For attaching drawer fronts or mounting wooden drawer and door pulls, versions with extra-wide washer heads let you make minor adjustments within an oversize shank hole.



### CABINET-CONNECTING

Developed in Europe during the 1970s as the Conformat screw, these fasteners grip medium-density fiberboard or particleboard without splitting it. The 7x50mm size handles most 3/4" materials. A stepped pilot-hole bit made for these screws drills a wider hole for the shank plus a countersink. When appearance matters, hide the PozDrive screwheads (see Common drive types, next page) with plastic caps.



## The right tools yield faster fastening

Whether you use traditional or modern screws, today's countersink/counterbores drill a pilot hole, shank hole, and countersink all at once.

### FOR TRADITIONAL WOOD SCREWS

**Tapered drill bits with movable countersinks** match a traditional screw's shape and length.



### FOR MODERN SCREWS

**Use a countersink/counterbore combination** sized for #4, #6, #8, or #10 screws. To match the pilot-hole depth to the screw length, just shorten or extend the drill bit. Counterbore diameters measure 3/8" or 1/2" for standard wooden plugs.



To order either style countersink/counterbores, visit Lee Valley, 800-871-8158, [leevalley.com](http://leevalley.com); or McFeely's, 800-443-7937, [mcfeelys.com](http://mcfeelys.com).



# Flathead and panhead screw specs at a glance

		Flathead Screws						Panhead Screws				
Gauge		4	6	8	10	12	14	4	6	8	10	12
Head Diameter		3/4"	21/64"	11/32"	23/64"	7/16"	1/2"	7/32"	9/32"	5/16"	3/8"	27/64"
Pilot-Hole Diameter*	Hardwood	5/64"	7/64"	1/8"	9/64"	5/32"	3/16"	3/32"	7/64"	1/8"	9/64"	5/32"
	Softwood	1/16"	3/32"	7/64"	1/8"	9/64"	5/32"	5/64"	3/32"	7/64"	1/8"	9/64"
Range of Commonly Available Lengths		3/8" 1/2" 5/8" 3/4"	1" 1 1/4" 1 1/2" 1 3/4"	1" 1 1/4" 1 1/2" 1 3/4" 2" 2 1/4" 2 1/2" 2 3/4" 3" 3 1/2" 4"	1" 1 1/4" 1 1/2" 1 3/4" 2" 2 1/4" 2 1/2" 2 3/4" 3" 3 1/2" 4"	1" 1 1/4" 1 1/2" 1 3/4" 2" 2 1/4" 2 1/2" 2 3/4" 3" 3 1/2" 4"	1" 1 1/4" 1 1/2" 1 3/4" 2" 2 1/4" 2 1/2" 2 3/4" 3" 3 1/2" 4"	1" 1 1/4" 1 1/2" 1 3/4" 2" 2 1/4" 2 1/2" 2 3/4" 3" 3 1/2" 4"	1" 1 1/4" 1 1/2" 1 3/4" 2" 2 1/4" 2 1/2" 2 3/4" 3" 3 1/2" 4"	1" 1 1/4" 1 1/2" 1 3/4" 2" 2 1/4" 2 1/2" 2 3/4" 3" 3 1/2" 4"	1" 1 1/4" 1 1/2" 1 3/4" 2" 2 1/4" 2 1/2" 2 3/4" 3" 3 1/2" 4"	1" 1 1/4" 1 1/2" 1 3/4" 2" 2 1/4" 2 1/2" 2 3/4" 3" 3 1/2" 4"
Square-Drive Bit		#0	#1	#2	#2	#3	#3	#0	#2	#2	#2	#3
Phillips-Drive Bit		#1	#2	#2	#3	#3	#3	#1	#2	#2	#3	#3

\* Shank holes are seldom needed for today's screws. If the screw needs to turn freely, drill an oversize hole the next pilot hole size up.

## Common drive types from dependable to difficult

Very little driver-bit slippage



Torx/star



Square



PoziDrive



Square/Phillips



Phillips



Slotted

For fewest hassles, use Torx/star or square-drive screws. The square-drive design is available on a wide variety of flathead and panhead screws.

PoziDrive and square/Phillips combinations are widely available at home centers on screws meant for building decks and outdoor projects.

Because of these slippery culprits, woodworkers have long wanted ways to prevent screwdrivers from jumping loose from screwheads, or cam-out.

Better Homes and Gardens®

# WOOD PATTERNS®

July 2009

Issue 191

Dear Reader: As a service to you, we've included full-size patterns on this insert for irregular shaped and intricate project parts. You can machine all other project parts using the Materials List and the drawings accompanying the project you're building.

© Copyright Meredith Corporation, 2009. All rights reserved. Printed in the U.S.A. Meredith Corp., the publisher of WOOD Patterns®, allows the purchaser of this pattern insert to photocopy these patterns solely for personal use. Any other reproduction of these patterns is strictly prohibited.

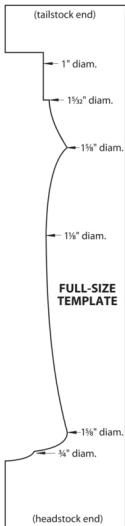

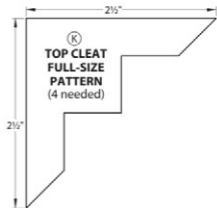
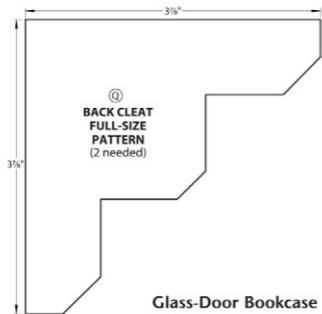

Glass-Door Bookcase  
Page 34

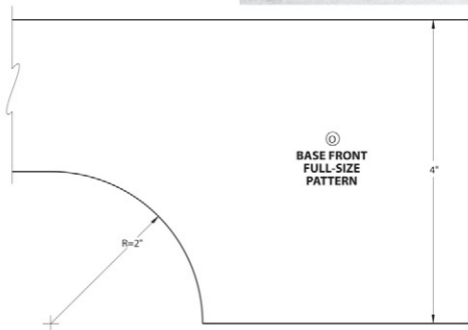

## Bright-Idea Candleholder Page 20

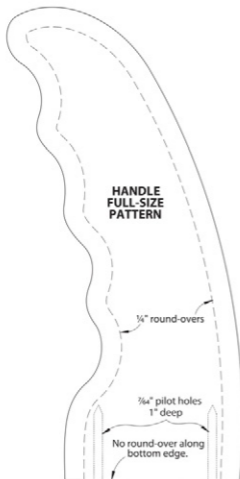
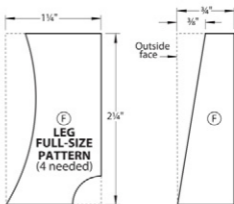

## Cope-Cutting Sled Page 32



# Make Cabinets the Easy Way

Big? Yes. Difficult? Nah. With only basic woodworking skills, a tablesaw, and a few simple tools, you can make custom cabinets for your home or shop.



Okay, let's hear 'em—your excuses for not making those cabinets you could use everywhere from your kitchen to your workshop: "Oooh, they have doors." Relax. You can make doors using just your tablesaw and a general-purpose blade to cut the joints.

"But...but, they have drawers!" Imagine making a simple box without a top, and you're picturing most of the skills needed to make these drawers using only a tablesaw. You'll mount those boxes with simple glides that nearly install themselves and adjust to clean up

minor installation errors. Then mount the drawer fronts to the boxes for dead-on alignments. No sweat.

"Umm, I have to go to the bathroom." Then take some measurements for a new bath vanity while you're in there, and catch up with us on the next page.

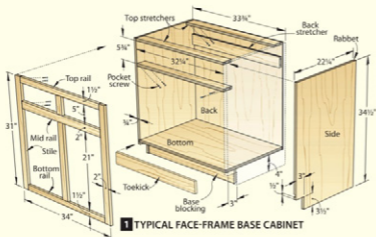

**1** TYPICAL FACE-FRAME BASE CABINET

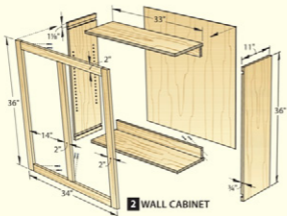

**2** WALL CABINET

melamine-covered particleboard, and solid wood. Double-check the material thickness before calculating cabinet sizes and cutting dadoes and rabbets.

Build the face frame from solid wood to match or contrast with the sides. Choose clear, straight-grained wood, and assemble the frame soon after machining to reduce warping.

### Standards help you design

Over the years, cabinetmakers have standardized some cabinet dimensions based on practical considerations, such as the average height of people. You needn't adhere strictly to these, but vary them at your own risk of discomfort.

- Standard base cabinets measure 34 1/2" high, for a 36"-high work surface with a 1 1/2" countertop.

- At 24" deep, standard base cabinets allow you to bend over and reach in to retrieve anything at the back.

- Make cabinets as wide as you like, but remember that the wider the doors, the greater the tendency to rack and warp. Also, the wider the door, the more clearance you'll need in front of the cabinet.

- Standard wall cabinets measure 12" deep. Deeper cabinets hinder access to the countertop below.

- Wall cabinets commonly mount 18" above the base-cabinet countertop.

### Fit the case to an opening

To allow built-in cabinets a margin for unsquare walls. Design the case 1/2" narrower than the opening between another cabinet and a wall or between two walls. You'll fill the gap with the face frame overlap on the sides.

To calculate part sizes for a base cabinet that's wider or narrower than the one above left, follow this formula:

1. Multiply the thickness of the plywood or MDF sides times two.....\*
2. Add 1/2" to allow for two 1/2"-deep dadoes joining the bottom to the sides.....\*
3. Subtract that number from the case width.....\*

Cut the cabinet bottom to that length. For example, to make a cabinet 33 3/4" wide using 3/4" plywood, cut the case bottom 33" long. To size the stretchers, use that same number minus the 1/4" dado allowance. Calculate upper cabinet sizes the same way.

## Begin with the right cabinet dimensions

The sample base and wall cabinets shown above have these features to make building them as simple as possible:

- The 3/4" plywood case eliminates panel jointing, planing, and glue-ups.
- Face frames cover plywood edges. Overlaps on the sides let you fine-tune the cabinet width during installation.
- Plywood-panel doors and drawer fronts require no routed profiles.

- The drawer slides we recommend provide lots of mounting flexibility and the chance to undo minor mistakes.

### A word about materials

The cabinet cases shown here were made from birch-veneer, medium-density fiberboard (MDF)-core plywood for economy. You can instead use hardwood-veneer plywood, solid MDF, plain or

# Make a no-fuss case using your tablesaw

For a base cabinet less than 4' wide, you can cut all the parts except the back and toe-kick from one  $3/4$ " $\times$ 4' $\times$ 8' sheet of plywood or MDF. Plywood thicknesses vary, though, so make certain your material thickness measures a true  $3/4$ ", or adjust your part dimensions to achieve the final cabinet width.

Start by ripping two side pieces to the cabinet depth (minus the frame thickness); then cut them to length. Label them left and right with pencil marks on the inside faces. Now subtract the thickness of the back from your fence setting, and cut the bottom panel to width. Then cut the bottom to length.

Using the plywood thickness to set the stacked dado width, cut a  $3/8$ "-deep dado on the inside face of each side piece to accept the bottom. You can use the

same setup to cut  $3/8$ "-deep rabbets along the inside back edge of the sides to accept the cabinet back. Then notch the bottom front corner of both side pieces for the toe kick [Photo A].

Now cut four  $2\frac{1}{2}$ "-wide stretchers and a  $3\frac{1}{2}$ "-wide base block. Drill two pocket holes on both ends of each part. If you'll add an adjustable shelf within the case, lay out and drill shelf pin holes on both sides. For even spacing, make a template from a piece of perforated hardboard as a drilling guide. To watch a free video on how to drill shelf pin holes, go to [woodmagazine.com/shelfholes](http://woodmagazine.com/shelfholes).

## Putting it all together

A dead-square cabinet requires a dead-flat assembly surface to avoid twisting the glue-up. First lay a side panel on your

work surface with its dadoed face up. Apply glue to the dado and insert the bottom. Then glue the dado on the other side panel dado and mount it on the bottom. Support the other end of the side panel with top stretchers that you'll pocket-hole-screw in place.

To calculate the front drawer stretcher position, add 1" to the height of the drawer boxes you'll make. Then cut two stretchers that length to space the front drawer stretcher that distance from the front top stretcher and pocket-hole-screw the drawer stretcher in place [Photo B].

Measure and center the back drawer stretcher flush with the bottom of the front drawer stretcher. Check for square, as with the upper cabinet [Photo C]. After the glue dries, cut the back to fit. Then glue and nail it in place.

### CUT TOEKICK NOTCHES



**A** A toe kick allows you to stand closer to a cabinet without bumping the front with your feet. Cut these clear of the case bottom dado.

### ADD STRETCHERS TO THE CASE



**B** Scrapwood spacers ensure consistent alignment while you install the stretchers with pocket-hole screws.

### EQUAL DIAGONALS = SQUARE CASE



**C** Measuring for equal diagonals to check for square works as well for this upper case as for the lower one and the drawer boxes.

# Pocket holes simplify face-frame assembly

You can join face frame parts using everything from dowels to half-laps to mortise-and-tenon joints, but we like pocket-hole joinery. Here's why:

- Machined or hand-cut joints may display your skill, but they'll take longer to make than the case itself.
- They eliminate gluing and clamping.
- Though weaker than some cut joints, pocket-hole joints gain strength after you mount the frame on a case.

Cut frame parts from straight-grain  $3/8$ "-thick stock  $1\frac{1}{2}$ " or 2" wide, depending on the part. Why those sizes? Frame parts narrower than  $1\frac{1}{2}$ " don't mount easily to the case, while parts much

wider than 2" interfere with access to the cabinet.

## Cut your face frame parts

Begin by cutting 2"-wide stiles  $1/8$ " longer than the dimension from the toe kick cutout to the top of the case (31" in this case). If you need to allow for uneven walls, make the stiles  $2\frac{1}{4}$ " wide, and later trim the overhangs on the sides to fit the opening. You'll also cut the middle rail beneath the drawers 2" wide.

From  $1\frac{1}{2}$ "-wide stock, cut the top and bottom rails. To calculate the length of all three rails, measure the case width and add  $1/4$ " for the two  $3/8$ " overhangs.

### SCREWS JOIN FRAME PARTS



**D** Pocket screws eliminate the need for clamps as you assemble the frame. Screws won't show after you glue the frame to the cabinet.

From that number, subtract twice the stile width for the rail lengths. Rout a  $\frac{1}{8}$ " round-over on the top inside edge of the bottom rail.

Position the middle rail so its top edge is flush with the upper face of the middle stretcher. Cut the upper and lower vertical dividers to fit between the middle rail and the top and bottom rails. Using two pocket-hole screws at each joint, assemble the frame [Photo D].

### Glue the frame to the case

Apply glue to the case edges; then center the frame between the case sides with the lower frame rail inside edge  $\frac{1}{8}$ " above the inside face of the case bottom. Check that the top stile ends sit flush with the top ends of the case sides. Clamp the frame in place, including the middle rail [Photo E]. If you'll paint the cabinet, save clamping time by gluing and nailing the frame to the case. Then fill the holes.



Clamp rail to drawer stretcher.

### E CLAMP THE FRAME TO THE CASE

You don't need a shop full of clamps to attach the frame to the case, but make sure you glue the middle rails to the drawer stretcher.

## Make these doable doors on your tablesaw

If you have put off learning to make cabinet doors, these easy-to-cut sub-tenon-and-groove joints will help you overcome your door horror. Divide the job into these six simple steps.

**1** From  $\frac{1}{2} \times 2$ " blanks, cut two stiles to the door height (A), shown at right.

**2** From the overall width of your door, subtract 4" for the two 2"-wide stiles (B), add  $\frac{1}{2}$ " for the tenons, and cut the rails to that length (C).

**3** Set your tablesaw blade height to  $\frac{1}{8}$ " and position the fence to center a test piece on edge over the blade. Then cut a groove the length of the scrap. To ensure the groove is centered, turn the scrap end for end, and make a second cut [Photo F]. Gradually move the fence away from the blade until you've cut a centered groove to match the plywood panel thickness. Cut grooves in both stiles and rails.

**4** A dado blade speeds cutting tenons on the rails, but multiple passes with a general-purpose blade will do just as well. Set the blade height to  $\frac{1}{8}$ ", then double-face-tape an extension to your miter gauge and a spacer block to the fence about 4" back from the blade [Photo G]. Adjust the fence until you cut a  $\frac{1}{8}$ " tenon on test scrap that just bottoms out in the stile grooves.

**5** Cut the panel width (A) and length (E) a hair smaller than the space between the stile and rail groove bottoms. If you'll stain the doors, stain the panels before assembling the frame.

**6** Apply glue to the tenons plus a dab centered in each frame part groove to keep the panel from rattling. Assemble and clamp the frame and panel, measuring between diagonal corners to check for square.

### NO ROUTER REQUIRED FOR JOINTS

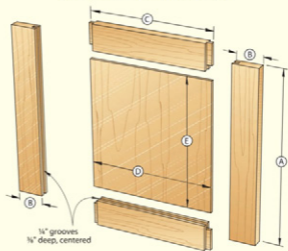

Edge-grooves in the stiles and rails can be sized to fit your panel thickness.

### TEST GROOVE WIDTH IN SCRAP



Set the fence position and blade height using scrap the thickness of your workpiece.

### CUT TENONS THE SAME LENGTH



A spacer moves the fence away from the blade for cutting tenons.



## Now mount the doors on your cabinet

Thanks to their adjustability, European-style hinges make mounting doors as easy as assembling them. Begin by drilling  $1\frac{1}{2}$ " holes  $\frac{1}{2}$ " deep with a Forstner bit [Photo H]. We positioned the holes  $4\frac{1}{4}$ " from the top and bottom of the door for plenty of clearance, with the center of the hole  $\frac{1}{8}$ " from the stile edge.

Place a hinge cup in a hole with the straight hinge edge parallel to the stile edge [Photo I], and mark the center of the mounting screw slots. Then drill screw pilot holes and install the hinge. Repeat for the other hinge.

Hold the door in position centered vertically in the opening, and mark each hinge screw mounting location (at the center of each oblong hinge screw hole)

along the frame edge. Drill pilot holes and screw the door to the frame. Refer to

the hinge instructions for details on adjusting the door position.

### DRILL HINGE CUP HOLES



**H** European-style hinges require 35mm holes in the door, but a  $1\frac{1}{2}$ " Forstner bit also works.

### INSTALL AND ADJUST HINGES



**I** Fine-tune the door position after installation using hinge adjustment screws.

## How to take the horrors out of drawers

Imagine all the potential pitfalls about making drawers. Then imagine they don't exist—because for this drawer, they don't:

- No router joints required. Cut both halves of the joint on your table saw.
- No fussy alignments. The false drawer front aligns separately from the box.
- No tricky drawer-glide installations. The hardware we recommend allows many ways to fine-tune the position.

From  $\frac{1}{2}$ " $\times$ 4" blanks, cut the sides to the drawer-box length—18" for the cabinet shown on page 51. Then subtract  $\frac{1}{2}$ " from the drawer opening width in the frame, and cut the front and back to that size ( $12\frac{1}{2}$ " for this example).

On the bottom inside edge of each piece, cut a groove  $\frac{1}{8}$ " from the edge to accept the drawer bottom. (Our drawer bottom sheets measured  $\frac{1}{8}$ " thick.)

Set your table saw fence  $\frac{1}{8}$ " from the edge of a  $\frac{1}{8}$ " dado blade set  $\frac{1}{8}$ " high, as shown in Step 1 below left. Test the saw

settings in scrap; then cut dadoes at both ends of the two sides.

Attach a  $\frac{1}{4}$ " spacer to the rip fence, as shown in Step 2 below right. It should just touch the teeth of the blade. Next, rabbet both ends of the drawer front and back to create a tenon that fits the side dadoes [Photo J]. Glue each tenon, assemble and clamp the drawer, and then check for square.

To buy a video of this drawer-making technique, go to [woodmagazine.com/simplerdrawer](http://woodmagazine.com/simplerdrawer).

Assemble a frame-and-panel drawer front as you would a small version of a cabinet door. Then mount the glides [Photo K] on the case and on the lower

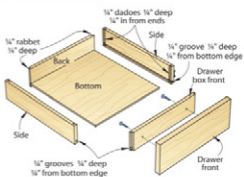

edge of the drawer box side according to the product instructions. Make the front of the drawer box flush with the frame.

### USE ONE JOINT FRONT AND BACK



Tenons should fit dadoes snugly, with the outside faces of the front and back flush with the ends of the sides.

### ONE SHIM ALLOWS A SINGLE SETUP TO CUT BOTH JOINT HALVES

Cut  $\frac{1}{8}$ " dadoes  $\frac{1}{8}$ " deep into both ends of the drawer-box sides.

STEP 1

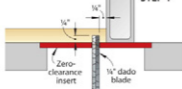

Cut a  $\frac{1}{4}$ " rabbet  $\frac{1}{8}$ " deep into both ends of the drawer-box front and back.

STEP 2

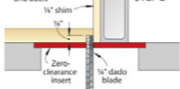

### INSTALL SUPER-SIMPLE GLIDES



**K** The plastic mounting bracket lets you adjust these slides up and down and side-to-side for smooth-opening drawers.

### ATTACH THE DRAWER FRONT



**L** A spacer on the door precisely positions the drawer front as you press it against the drawer box.

### DRILL DRAWER-PULL HOLES



**M** A template ensures centered, precise holes for your drawer-pull hardware, no matter how many drawers you make.

With the doors installed and aligned with each other, lay a spacer the width of the space between the doors and drawer fronts atop the door [Photo L]. Apply double-faced tape to the inside face of the drawer front, align it with the

door, and press it against the drawer box. Then drill pilot holes from the inside front of the drawer box to the drawer front frame, and screw on the front.

Make a template the size of the exposed panel on the drawer front, and

center two mounting holes to suit your hardware. Place the template on the drawer front panel [Photo M], and drill the hardware mounting holes. Then install the drawer pulls. Use longer screws as needed for your hardware.

## Put your finished cabinets to work

Remove the doors, drawers, and all hardware, and apply a finish. Move the cases into position where they'll be installed. Shim the bottom edges to level the cabinets and make the face frame edges parallel with each other.

Clamp the cabinet face frames together while you screw them to the wall and each other. (Specialty clamps made for installing cabinets, see Sources, ensure the faces also will be flush.) To compensate for the frame overlap, add a  $\frac{1}{8}$ " spacer between the cases toward their backs and between the clamps [Photo N]. Then drill pilot holes and screw the frames together [Photo O] and the cabinets where you inserted the  $\frac{1}{8}$ " spacers.

Next you'll need a countertop sized to overlap the front or both the front and sides about  $\frac{1}{2}$ "–2". We made ours from two sheets of MDF edged with maple—a practical choice for shop use. In a kitchen or bath, though, countertop options include a butcherblock, plastic laminate, solid-surface, granite, and tile.

To hold the upper cabinet in place while you screw it to the wall, make two 18"-tall temporary supports from scrap. Place them on  $\frac{1}{2}$ " spacers, and rest the upper cabinet on the supports [Photo P]. After you screw the cabinet in place, slide out the  $\frac{1}{2}$ " spacers to allow enough room for the temporary supports to tilt out from under the cabinet.

Remount the doors and drawers, fill up your new cabinets, and start scouting other locations in your shop, garage, kitchen, or bathroom for new cabinet-making opportunities. 📌

Written by **Bob Wilson** with **Kevin Boyle**  
Illustrations: **Roxanne LeMoines**; **Lorna Johnson**

### SPECIAL CLAMPS SPEED INSTALLATION WORK



**N** Any clamps will hold cases together, but this clamp also holds the faces flush and provides a pilot-hole drilling guide.



**O** To join cabinets, flip down the drilling guide and drive a panhead screw into both frames. Use at least two screws to connect frames.

### SCREW UPPER CABINETS IN PLACE



**P** Supports hold upper cabinets 18" above the countertop while you drive mounting screws. Spacers make the supports easy to remove.

# The fully adjustable Universal Clamp Rack



Two 48" double-slot wall standards and six mating 12" shelf brackets form the core of this all-encompassing clamp storage system.

**B**ecause you can never have too many clamps, woodworkers tend to accumulate a lot of them. And because clamps come in a variety of sizes and shapes, storing them can be tricky. Here's a simple solution based on commonly available adjustable shelf hardware. We'll show you how to build six outside supports and three center supports to make three clamp racks.

## EXPLODED VIEW (Viewed from the back)

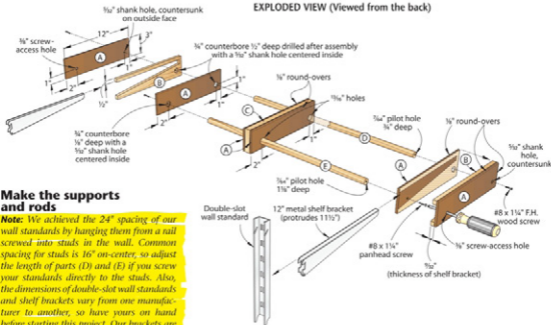

## Make the supports and rods

**Note:** We achieved the 24" spacing of our wall standards by hanging them from a nail screwed into studs in the wall. Common spacing for studs is 16" on-center, so adjust the length of parts (D) and (E) if you screw your standards directly to the studs. Also, the dimensions of double-slot wall standards and shelf brackets vary from one manufacturer to another, so have yours on hand before starting this project. Our brackets are 2" wide at the base and protrude 1 1/2" from the standards. Measure your brackets and adjust the width and length of parts (A), (B), and (C) as needed.

**1** To make the bracket cutouts in the support covers (A) to size [Materials List, page 58]. Then from 3/4"-thick stock, cut the end cores (B) and center cores (C). (We used poplar. Any hardwood or softwood will work.) Now measure the exact thickness of your shelf brackets, and plane the cores to this dimension. (Our brackets measured slightly less than 3/8" thick.)

**2** To make the bracket cutouts in the end cores (B), where shown on the drawing, first draw a line on one face of an end core parallel to and 1/2" down from the top edge. Place a shelf bracket on the end core, aligning the top edge of the bracket with the line and letting the prongs that engage the wall standard protrude beyond the rear end. Trace the outline of the standard onto the core with a pencil. Then bandsaw the cutout. Test the fit of the bracket and make any necessary adjustments. Now use this core to trace the bracket cutout onto the other end cores. Bandsaw the cutouts.

**3** Spread glue on the faces of the end cores (B) and center cores (C) and clamp each of them between two support covers (A), keeping the ends and edges flush.

**4** To set up your drill press to bore perfectly aligned holes and counterbores

in the supports (A/B, A/C), chuck a 13/16" Forstner bit and position the fence 1" from the center of the bit. Then, for boring the front holes and counterbores, clamp one stopblock to the fence 11" to the right of the bit center and another stopblock 11" to the left of the bit center. (To accommodate the 12"-long supports, you may need to attach a long auxiliary fence to your drill-press fence.) Now for boring the rear holes and counterbores, cut a 1"-wide spacer.

**5** Retrieve the three center supports (A/C) and bore two 13/16" holes through each one to accept the rods (D, E) [Photos A and B].

**6** Retrieve the end supports (A/B) and mark the inside face of each support near the front end with a piece of masking tape. You'll have three right-hand end supports and three left-hand end supports that are mirror images. Mark an R or L on the masking tape according to the position.

## STOPBLOCKS AND A SPACER ENSURE QUICK AND ACCURATE BORING



**A** With the center support (A/C) bottom edge against the fence and the rear end against the right stopblock, bore the front hole.



**B** Slide the center support (A/C) to the left, inserting a 1"-wide spacer between the part and stopblock. Bore the rear hole.

## ASSEMBLE THE CLAMP RACKS

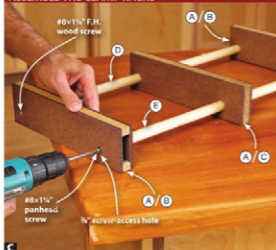

**C** With the rods (D, E) inserted in the center support (A/C), position the end supports (A/B), drill pilot holes, and drive the screws.

**7** Chuck a  $\frac{3}{8}$ " Forstner bit into your drill press, and set the drill-press depth stop to bore  $\frac{1}{2}$ " deep into the end supports (A/B). Then, with the bottom edges against the fence and the inside faces up, position the rear ends of the right-hand end supports against the right-hand stopblock and drill the front counterbores. Now position the rear ends of the left-hand end supports against the left-hand stopblock and drill the front counterbores. Switch to a  $\frac{1}{2}$ " bit and drill shank holes centered in the counterbores. Countersink the shank holes on the support's outside faces.

**8** Switch to a  $\frac{3}{8}$ " Forstner bit and set the drill-press depth stop to drill  $\frac{1}{4}$ " into the end supports (A/B). Then, using

the 1" spacer between the end support and the stopblocks in the same manner shown in **Photo B**, bore the  $\frac{3}{8}$ " counterbores  $\frac{1}{8}$ " deep in the inside faces of the end supports, where shown on the drawing. Then switch to a  $\frac{1}{2}$ " bit and drill shank holes centered in the counterbores. Now switch to a  $\frac{3}{8}$ " bit, flip the supports over, and drill screw-access holes through the outside faces.

**9** Chuck a  $\frac{3}{8}$ " round-over bit into your table-mounted router and rout all ends and edges of the end supports (A/B) and center supports (A/C). Then, from  $\frac{3}{8}$ " dowels, cut the front rods (D) and rear rods (E) to length. Finish-sand the supports and rods to 150 grit.

## Finish and assemble

**1** Apply a clear finish to all the parts. (To avoid scuffs and scratches but still provide some protection, we applied two coats of Minwax Antique Oil Finish.)

**2** Insert the front rods (D) and rear rods (E) into the  $\frac{13}{16}$ " holes in the center supports (A/C). Then, inserting the rods into the end support (A/B) counterbores, use the shank holes in the inside support covers (A) as guides and drill pilot holes into the ends of the dowels. Drive the screws (**Photo C**).

**3** Screw the hanging bracket to the top plate of the wall; then hang two

## MOUNT THE RACKS ON THE WALL



**D** With the standards and brackets in place, slide the outside supports (A/B) of each clamp rack over each pair of shelf brackets.

double-slot wall standards from the bracket, positioned 24" center-to-center. Next, install three shelf brackets on each standard. (We located ours 16" apart vertically.) Then mount the clamp racks on the brackets (**Photo D**). To store bar clamps of less than 24" clamping capacity, slide the center supports (A/C) to the appropriate position between the end supports (A/B). Rest the clamp bars on the center support and one end support. You can store more clamps by hanging them on the rods (D, E) or clamping them to the supports (A/B, A/C). Now round up all your clamps, and organize them in one handy place.

Written by **Jan Svec** with **Chuck Hedlund**

Project design: **Mark Lea**, Seattle, Wash.

Illustrations: **Roxanne LeMoine**; **Lorna Johnson**

## Cutting Diagram

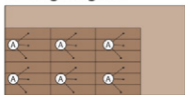

$\frac{1}{4}$  x 24 x 48" Hardboard

$\frac{1}{4}$  x 3 1/2 x 36" Hardwood or softwood (1 bd. ft.)

$\frac{1}{4}$ "-diam. Hardwood dowel 48" long (3 needed)

$\frac{1}{4}$  x 3 1/2 x 96" Hardwood or softwood (2.7 bd. ft.)

\*Plane or resaw to the thickness listed in the Materials List.

## Materials List

Part	FINISHED SIZE			Matl.	Qty.	
	T	W	L			
A	support covers	3"	12"	H	18	
B	end cores	9"	3"	12"	C	6
C	center cores	9"	3"	12"	C	3
D	front rods	1/4" diam.	24"	D	3	
E	rear rods	1/4" diam.	23 1/4"	D	3	

**Materials key:** H—tempered hardboard, C—choice of hardwood or softwood, D—hardwood dowel.

**Supplies:** 48" double-slotted wall standards (2), 40" horizontal hanging bracket (1), 12" shelf brackets for double-slot standards (6), #8x1 1/4" flathead wood screws, #8x1 1/4" panhead screws.

**Bits:** 1/4", 1/2" Forstner bits, 1/4" round-over router bit.

Fun-in-the-sun

# Picnic Table

Solid seating for summertime entertaining



**BASIC-BUILT**

GREAT PROJECTS MADE SIMPLE.

## WHAT YOU'LL NEED



Feel free to load up this table with eight people, food, fixin's, and refreshments. The notched frame pieces lock together like Lincoln Logs, making the table solid as a rock. Cutting the notches requires only a circular saw.

By choosing the right materials, this table will serve you well for many summers to come. We used dimensional ("2-by") cedar from a home center for its resistance to weather and insects. (See the **Skill Builder** on the opposite page for more about preparing dimensional lumber.) Other suitable choices would be redwood, cypress, and treated Southern yellow pine.

## Set up the seats

**1** Cut the bench rails (A) and legs (B) to size [Materials List, page 65], miter-cutting the ends of the bench rails and legs [Drawings 1, 1a].

**2** Clamp the bench rails (A) together with their edges and ends flush, and cut a notch centered on their length [Drawing 1]. See the article on page 28 for tips on cutting joints with a circular saw.

**3** Use a fairing stick to lay out the arch on the bottom of each rail (A) [Drawing 1, Photo A]. (See **More Resources** on page 65 to find a free plan for a fairing stick.) Cut the arches with a jigsaw, and sand them smooth.

## SKILL BUILDER

### Tips for working with dimensional lumber

Compared with hardwoods, dimensional lumber (such as 2x4s and 2x6s) has a high moisture content, so it requires some special preparation before you start cutting.

The first step: Simply let it dry further. Stack it in your shop with 1/4"-thick scrap spacers between each layer to allow air circulation.

After at least a week of "seasoning," prepare the stock for a particular assembly, such as the benches, at one time. Crosscut each piece to rough length with a circular saw. To square up the rounded edges, rip the piece on the table saw to 1/8" wider than finished width. Place the freshly ripped edge against the rip fence, and cut the piece to its finished width. Then crosscut the pieces to finished length with the circular saw.



#### 1 SEAT ASSEMBLY

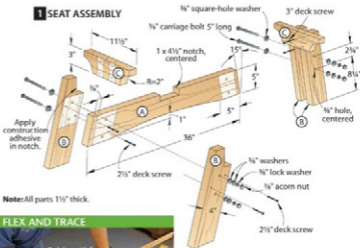

Note: All parts 1 1/2" thick.

#### FLEX AND TRACE



A thin piece of scrap serves as a fairing stick. Clamp a cutoff near each end of the rail (A), and flex the scrap to lay out the arch.

#### 1a LEG AND TABLE RISER

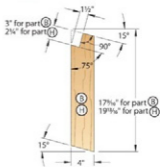

#### 1b OPTIONAL END DETAIL



**4** Cut the cleats (C) to size. (Save a short piece of the cutoff from the cleats for use later.) Lay out and cut a curve on each end of the cleats [Drawing 1]. **Option:** Instead of curves, you could cut a miter [Drawing 1b]. Sand away any saw-blade marks. Set the cleats aside for the moment.

**5** To lay out the notches for the cleats (C) in the legs (B), draw a line 3" from the mitered top of one leg, parallel with the end. Align the scrap cutoff from a cleat with the end of the leg and the line [Photo B]. Trace around the cutoff. Clamp the legs together, and set the saw blade as shown in Photos C and D. Make a cut

#### SCRAP YOUR LAYOUT



Prevent errors that can creep in with measurements by tracing around a cutoff from a cleat (C) to lay out the leg notches.

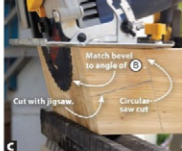

**C USE LAYOUT FOR SAW SETUP**

The ends of the legs make a perfect gauge for setting the bevel angle of the saw blade (left photo). Set the blade depth so the lowest tooth just touches the intersection of the layout lines (right photo). Make the cut to just leave the pencil mark.



**D**



**E SECURE THE LEGS TO THE RAILS**

Screw the legs and rails together. They will be secured permanently with bolts after the cleats are added.

across the legs to establish the bottom of the notch. Unclamp the legs. Switch to a jigsaw to make the intersecting cut on each leg. Sand with 150-grit sandpaper to smooth all pieces.

**6** Draw a line around each end of the bench rails (A)  $\frac{3}{8}$ " from the end. Lay the rail on a leg (B) flush with the line [Photo E], and screw the rail to the leg [Drawing 1]. Position another leg on the top face of the rail, and screw it in place. Repeat for the remaining legs and rails.

**7 Quick Tip! Stick with a weather-proof adhesive.** Wherever glue was required on the picnic table, we applied construction adhesive. It holds up in wet conditions, and the thick consistency fills small gaps. Apply construction adhesive to the notches in the legs (B), center the cleats (C) on the leg assembly (A/B), and secure the cleats with 3" deck screws. Then drill  $\frac{3}{8}$ " holes for the carriage bolts through each set of legs, and install the bolts [Drawing 1]. See the Shop Tip below.

## SHOP TIP

### Get a better bite with square-hole washers

The square shoulders under a carriage-bolt head are meant to bite into the surrounding wood to prevent the bolt from turning while the nut is tightened. In softer woods, such as cedar or redwood, the shoulders may instead just tear away the fibers. The solution: square-hole washers, below, with teeth that bite into the wood and a square hole that captures the bolt's shoulders.

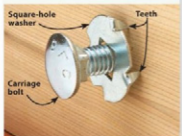

## 2 FRAME ASSEMBLY

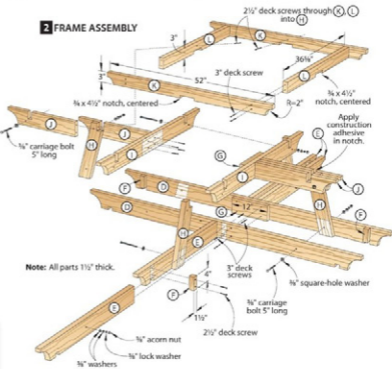

Note: All parts 1 1/2" thick.

## 2a BEAMS SIDE VIEW

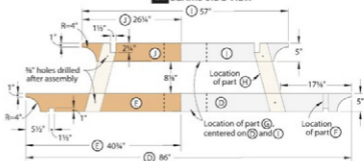

Note: All parts 1 1/2" thick.





**F MAKE HALF A FRAME**

Screw the bench beam (D) to the short bench beam assembly (E/F), then attach the long spacer (G) to this assembly.



**G JOIN THE HALVES**

Align the ends of the bench beams (D), and screw the two frame halves together. Screw into the short spacers (F) and long spacer (G).



**H SECURE THE RISERS**

Position the riser (H) flush with the bottom edge of the beams (D, E). A mitered scrap piece establishes the correct angle.

## Start at the bottom

**1** Cut the bench beams (D) and short bench beams (E) to size. As before, gang the pieces together to cut the  $1\frac{1}{2}$ " notches on the bottom edges [Drawing 2a]. Then create the arc (or miter) on each end of the bench beams and on one end of the short bench beams.

**2** Cut the short spacers (F) and long spacers (G) to size. **Option:** If you intend to use an umbrella with the table, cut four long spacers to a length of 6" instead. Set one long spacer (or two 6" spacers) aside for now. Using construction adhesive, glue and screw a short spacer above the notch in a short bench beam (E) [Drawing 2]. Glue another short bench beam to this assembly. Repeat this procedure for the remaining short bench beams. Glue the other two short spacers above the notches in a bench beam (D).

**3** Now create two halves of the bench frame. First, center a short bench beam assembly (E/F) on the length of a bench beam (D) [Photo F]. Place a  $1\frac{1}{2}$ "-thick temporary spacer between the short bench beams. Drive 3" deck screws through the bench beam into the ends of the short bench beams. Then screw a long spacer (G) to one of these assemblies [Photo F]. **Note:** To accommodate an umbrella, use two 6"-long long spacers. Leave between them a  $1\frac{1}{2}$ " gap that aligns with the gap in the short bench beams. Finally, clamp and screw the two frame halves together [Photo G].

**4** Cut the risers (H) to size. Miter each end, and cut a notch at the top in the same way as the legs (B) [Drawing 1a]. Miter the end of a piece of scrap to  $15^\circ$  as well. Place the base assembly (D/E/F/G) on a flat surface. Make a mark on the top edge of each beam (D, E)  $17\frac{1}{2}^\circ$  from the end [Drawing 2a]. Position a riser using the mark, the floor, and the scrap [Photo H]. Drill a pilot hole, and secure the riser with one screw. Attach the remaining risers in the same manner.

## Get on the beam

**1** Cut the table beams (I) and short table beams (J) to size. Lay out and cut the arcs (or miters) on each end of the table beams and on one end of the short table beams.

**2** Assembly of the table frame is similar to that of the lower frame. Instead of screwing spacers between the short table beams (J), temporarily clamp two  $1\frac{1}{2}$ "-thick scraps between them. Center this assembly on the length of a table beam (I), and screw through the table beam into the short beam [Drawing 2]. Do the same for the remaining beams. Retrieve the long spacer (G) (or the two remaining 6" spacers) set aside earlier. Screw the long spacer to a beam assembly (I/J), and screw the other beam assembly to the spacer.

**3 Quick Tip! Establish a support system.** Before proceeding, measure and cut temporary spacers to hold the table frame flush with the top of the risers [Photo I]. With help from a friend, place the table frame (G/I/J) onto the risers (H), with the spacers under the table frame. Pivot the risers so that the distance from the ends of the table beams (I, J) to the edge of each riser is the same. Clamp the table frame in place, and drive one screw into each riser.

**4** Lay out and cut notches in the table beams (I, J) next to the risers (H) [Photo J, Drawing 2a].

**5** Now cut the top cleats (K) to size and the top braces (L) to rough length of  $37\frac{1}{2}$ " [Drawing 2]. Draw a line on one edge of each piece centered on its length. Clamp the cleats and braces together with the edges flush and the centerlines aligned. Lay out and cut a notch to fit over the table frame (G/I/J). Then cut the arcs (or miters) on the ends of the top cleats.

**6** Glue and screw the top cleats (K) in place [Photo K]. Position the notches in the top braces (L) above the table

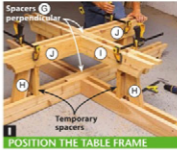

**I POSITION THE TABLE FRAME**

Support the table frame with temporary spacers, then position the risers (H) the same distance from the ends of the beams (I, J).



**J ALIGN NOTCHES WITH A NOTCH**

Cut the notch in the table beams (I) and short table beams (J) so the shoulder aligns with the notch in the riser (H).

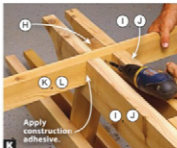

**K LOCK AND LOAD**

Apply construction adhesive to the notches in the table beams (I, J) before screwing the top cleats (K) and top braces (L) to the risers (H).



### L MARK LENGTH OF TOP BRACES

Align the notches in the top braces (L) with the short table beams (J). Mark each end, and cut the top braces to finished length.



### M SET THE SEAT SLATS

Fasten the seat slats (M) to the cleats (C) and bench beams (D, E) using construction adhesive and 2 1/2" deck screws.

frame. Mark the ends of the braces [Photo L], cut them to finished length, and glue and screw them into the notches in the short table beams (J). Drive screws through the top cleats into the top braces [Drawing 2].

7 Drill 3/8" holes for carriage bolts through the bench beams (D), short bench beams (E), table beams (I), and short table beams (J), and bolt the risers (H) in place [Drawing 2].

### Top it off

1 Have a friend help lift the table assembly (D-L) onto the four bench assemblies (A/B/C) [Drawing 3]. The notches in the bench beams (D, E) interlock with the notches in the bench rails (A). Cut the seat slats (M) to size. Lay out the arcs on the slats using a fairing stick [Drawing 4]. Lay out the corner curves as shown in the Shop Tip at right. Cut the seat slats to shape, rout round-overs

## SHOP TIP

### Found templates

Use a template to quickly lay out perfect curves at each corner of the seat slats. A 5" diameter sanding disc does the job. Lay out the shape of a slat, then align the disc so it touches both lines, and trace around the disc.

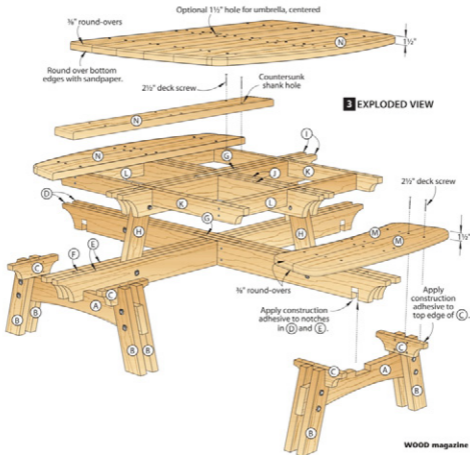

### 3 EXPLODED VIEW

around the curved top and bottom edges and ends (don't rout the straight edge), and sand them to 150 grit.

**2** Center an inner seat slat (M) on the length of each bench assembly (A/B/C), with the slat's straight edge centered on the length of the cleats (C). Screw the slats to the cleats and bench beams (D, E) [Photo M]. Mount the mating seat slats against the first.

**3** Cut the table slats (N) to size. Center one slat on the length and width of the table beams (I) [Drawing 4], and screw it down. **Note:** If you built your table to accept an umbrella, mark and drill the hole for the umbrella before securing the center slat. Secure the remaining table slats on either side of the center slat.

**4** Lay out the curve on each side of the tabletop, and cut the tabletop to shape [Drawings 4, 4a]. Rout a  $\frac{3}{8}$ " round-over around the top edge [Drawing 3]. Round over the sharp edges and ends on the bottom face with sandpaper.

**5** Sand all parts to 150 grit. Apply a finish. We used Behr deck stain (Cedartone No. 3-533, Semi-Transparent Deck, Fence & Siding Wood Stain). When the stain dries, invite friends over, chill the beverages, fire up the grill, and let the summer fun begin. 🍷

## Cutting Diagram

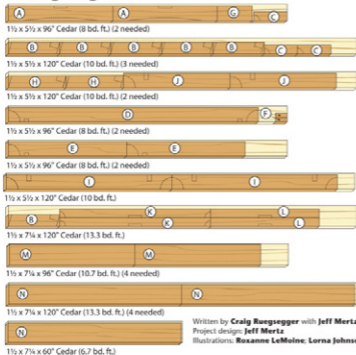

Written by **Craig Rueggesser** with **Jeff Mertz**  
Project design: **Jeff Mertz**  
Illustrations: **Roxanne LeMoine, Lorna Johnson**

## 4 SEAT/TABLE LAYOUTS

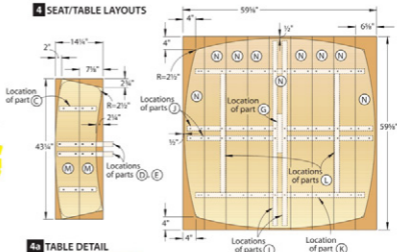

## 4a TABLE DETAIL

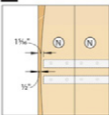

## MORE RESOURCES

### FREE PLAN

■ Instructions for making a fairing stick at [woodmagazine.com/fairing](http://woodmagazine.com/fairing)

### FREE VIDEO

■ Learn how to use a fairing stick at [woodmagazine.com/fairingvideo](http://woodmagazine.com/fairingvideo)

## Materials List

Part	FINISHED SIZE			Matl.	Qty.	
	T	W	L			
A	bench rails	1 1/2"	5"	96"	C	4
B	legs	1 1/2"	4"	17 1/4"	C	16
C	cleats	1 1/2"	3"	11 1/2"	C	8
D	bench beams	1 1/2"	5"	86"	C	2
E	short bench beams	1 1/2"	5"	40 1/4"	C	4
F	short spacers	1 1/2"	1 1/2"	4"	C	4
G	long spacers	1 1/2"	5"	12"	C	2
H	risers	1 1/2"	4"	19 1/4"	C	4
I	table beams	1 1/2"	5"	57"	C	2
J	short table beams	1 1/2"	5"	26 1/4"	C	4
K	top cleats	1 1/2"	3"	52"	C	2
L*	top braces	1 1/2"	3"	36 1/4"	C	2
M	seat slats	1 1/2"	7 1/4"	43 1/2"	C	8
N	table slats	1 1/2"	6 1/4"	59 1/2"	C	9

\*Part initially cut oversize. See the instructions.

### Materials key: C-cedar.

**Supplies:** 2 1/2" and 3" deck screws; 1/2" carriage bolts; 1/2" washers; 1/2" lock washers; 1/2" square-hole washers; 3/8" acorn nuts; construction adhesive.

**Bits:** 1/2" round-over router bit; 1 1/2" spade or holesaw drill bit (for optional umbrella hole).

### Source

Square-hole washers, box of 25, item no. 97449A103, 99.24, McMaster-Carr, 609-223-4200, [mcmaster.com](http://mcmaster.com).



It's a  
Jointer!

WOOD MAGAZINE  
**TOP  
VALUE  
APPROVED**  
Grizzly G0634

Face-joint stock  
up to 12" wide...

...lift the tables to  
switch to planer mode...

# 12" Jointer/Planers

Combination machines aren't just for the pros anymore. With two Asian-made models selling for half the price of European makes, even a hobby woodworker can joint and plane wide stock with one space-saving unit.



Watch a FREE video  
on using jointer/planers at:  
[woodmagazine.com/videos](http://woodmagazine.com/videos)

Jointers and planers work together in your shop like hot dogs and buns. One tool complements the other. But just as with hot dogs, typically sold in packages of 10, and buns, sold in 8-packs, the math doesn't add up: Jointers commonly come in 6" and 8" widths, while planers start at 12". European-style jointer/planers perform both tasks with equal ease—and 12" capacity—but have

never quite caught on in the United States thanks in part to price tags well north of \$3,000.

But in the last two years, some manufacturers have started selling Asian-made versions for about half that price. Curious if these models could hold their own against pricey European makes, we pitted the Grizzly G0634 (\$2,400) and Jet JJP-12 (\$2,000) against a \$4,600 Italian-made Mini-Max FS30 head-to-head.

Why should you buy one of these machines? First, you'll love being able to face-joint stock as wide as you can plane. And second, the prices of the Jet and Grizzly models nearly equal the prices of stand-alone 12" jointers, so it's like getting the planer for free. Plus, with a jointer/planer you gain a beefy 3-

hp induction motor and precious floor space that would otherwise be devoted to the second machine.

And changing from jointer to planer mode and back again proves easier than we expected. We found we could transform each machine (see the photo sequence, *above*) in less than a minute. And the more we used them the more efficient we got at making the change.

## Performance never lies

Despite the price difference, all three machines turned out smooth, precise, snipe-free workpieces that needed only

### QUICK-CHANGE KNIVES



To change Mini-Max's knives, tap the wedges to release pressure, then slide the knife through a hole in the bearing holder.



Jet JJP-12

Mini-Max  
FS30



...rotate the dust hood to cover the cutterhead...

...and thickness-plane stock up to 9" thick.

light sanding. Power was never an issue, even when we hogged away  $\frac{1}{8}$ " from 12"-wide hard maple. The differences between the machines lie in the details.

■ **Cutterhead.** Each tested machine sports a different type of cutterhead. The Grizzly features four spiral rows of 14 square carbide cutter inserts. (Grizzly also offers a straight-knife machine, model G0633, for \$1,900.) Each disposable insert rotates 90° to expose a new cutting edge should it become nicked. Replacement inserts cost \$40 per 10-pack. We prefer this style because the inserts are easy to change and their carbide edges stay sharp much longer than steel knives.

The Jet features a conventional-style cutterhead with three single-edged steel knives that can be resharpened. (Jet also offers a spiral carbide cutterhead model, JJP-12H11, for \$2,500.) Jet's bridge-style

cutterhead guard, shown *below right*, took some getting used to because we're more familiar with the traditional guards on the other two machines, but we grew to like it as well if not better.

Mini-Max's Tersa cutterhead holds its three dual-edged self-indexing, disposable straight knives in place with wedges and centrifugal force. That might sound scary at first, but when you turn on the machine with the knives in place, the wedges slip immediately into place tightly against the knives. Changes with this system proved easy, as shown *previous page*. Replacement knives, available in chrome (which we used), high-speed steel, and cobalt steel, cost from \$22 to \$50 per knife.

■ **Jointer fence.** All three aluminum fences, *below*, stand 6" tall with positive bevel stops at 0° and 45°. The 51½" Mini-Max fence—longest in the test—mounts

like a Biesemeyer-style tablesaw fence to a square rail at the end of the infeed table. It covers the entire infeed table and half of the outfeed. Grizzly's fence measures 39½" long and adjusts on a rack-and-pinion system that makes it 9" deeper (18" from the base to a wall) than the others. Two locking knobs stand above the fence and get in the way of your trailing hand when edge-jointing stock 8–12" wide. Jet's 43¾"-long fence mounts on a steel angled frame and secures with ratcheting handles. It proved the most difficult to use because it was not self-squaring with the cutterhead—adding another setup step when working with wide stock. We found the ratcheting handles troublesome because they sit so close to the frame.

■ **Changeover/dust collection.** Convenience in changing from jointing to planing and back proved about equal

#### MINI-MAX FENCE PROVES EASIEST TO USE

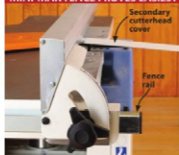

The Mini-Max fence mounts and moves like a T-square-style fence does on a tablesaw.



Grizzly's fence slides into a dovetailed block, secured by two locking bolts.



Jet's fence secures to the machine with two ratcheting-handled bolts.

## Do two jobs, save \$\$ with benchtop units

If the price of the 12" jointer/planners proves out of your reach, consider Jet's new lightweight benchtop models. The 8" unit (JJP-BBT, below) sells for \$330, and a 10" model (JJP-10BTOS) comes with a stand for \$420. Both feature a 13-amp universal motor and two-knife cutterhead. They arrived just before we sent this issue to the printer, so we were not able to do extensive testing. They displayed adequate power and cut quality, but the short tables made it tough to work with long stock. And because the jointer tables do not lift up, we found it difficult to feed stock less than 1½" thick into the planer because the tables get so close together. None of the tables can be adjusted to eliminate snipe or unparallel surfaces. Still, they seem a good option for someone on a limited budget getting started in woodworking.



on the three machines, with a slight edge to Mini-Max. All three machines require you to rotate a dust hood over the cutterhead when changing modes. (These hoods also act as cutterhead guards for planing.) To do this, you must first lower the planer table. With Jet's one-piece jointer table you don't have to remove the fence, but that advantage slips away once you raise the table: You must lower the planer table to the 6½" mark, about 3" more than the other two. And because that dust hood handles both operations, rotating it with the hose attached proves difficult.

Mini-Max and Grizzly have separate infeed and outfeed jointer tables, requiring you to first remove the fence, as well as separate dust hoods for jointing and planing. The jointer dust hoods mount under the infeed tables, so you have to change the hose from one hood to the other. Mini-Max's hoods have metric ports (about 4¾"); we simply inserted the 4" hose inside the ports with no clamps and got good results.

■ **Jointer tables.** Because these tables stand a few inches taller than the typical 32" of a stand-alone jointer (not including mobile base), jointing stock becomes more of an arm task and less about your entire body. Tables on the Grizzly and Mini-Max measure 59½" long to 55½" for the Jet. Because of these relatively short tables you'll need to add auxiliary support for boards longer than 6'.

The Grizzly is the only model with polished cast-iron tables. The other manufacturers say their grooved cast-

iron tables create less friction, but we found they *added* resistance—even when we used surface lubricants—compared to the smooth-sliding Grizzly.

■ **Planer.** All three units plane stock up to 9" thick and each has a heavy cast-iron table measuring about 23" long. Although each machine has a single feed speed, the Jet (20 fpm) and Mini-Max (23 fpm) produce slightly better finished surfaces than the Grizzly (22 fpm). This echoes results we've found in past tests: Straight knives leave cleaner surfaces than spiral carbide heads, which leave shallow linear grooves that need a little more sanding.

■ **Power switch.** All three machines sport magnetic switches, but only Grizzly provides a second "off" switch on the jointer outfeed side of the base. (In planer mode stock is fed from left to right.) Mini-Max has separate switches: a two-button twist-on to power the unit on the right, and an "off" button on the left. Jet's switch is located on the left and has a large, easy-to-locate "off" paddle.

## Our recommendation

Although we think you'd be happy with any of these machines, the Grizzly G0634 delivers very good results. It has an easy-to-change and long-wearing carbide cutterhead, smooth tables, a powerful 5-hp motor, and quirks we could live with. Although Mini-Max tested best overall, we can't say it's \$2,200 better. 🌲

Written by **Bob Hunter** with **Jeff Hall**

## GET TWICE THE WORK FROM A COMBINATION MACHINE

BRAND	MODEL	DIMENSIONS				CUTTERHEAD		PLANNER FEED RATE, FPM	PERFORMANCE RATINGS (2)				WEIGHT, LBS	WARRANTY, YEARS	COUNTRY OF ASSEMBLY (3)	SELLING PRICE (4)					
		OVERALL (WxDxH), INCHES	PLANNER TABLE LENGTH, INCHES	JOINTER TABLE LENGTH, INCHES	JOINTER FENCE LENGTH, INCHES	TYPE (1)	SPEED, RPM		PERFORMANCE RATINGS (2)												
									PRIMARY	SECONDARY	THIRDARY	FOURTHARY									
GRIZZLY	G0634	60x43x45	23½	59½	39½	C	5,035	22	A	B+	A	A	A	b	a	a-	a-	675	1	T	\$2,400
JET	JJP-12	55x31x40	21½	55½	43½	S	5,500	20	A	A	A	B	b	a	c	a	a	500	5	C	\$2,000
MINI-MAX	FS30	67x25x41	23	59½	51½	T	5,200	23	A	A	A	A	A	a	a	a-	a-	650	1	I	\$4,600

1. (C) Carbide inserts  
(S) Straight knives with jackscrews and gibs  
(T) Tersa insert knives

2. **A** Excellent  
**B** Good  
**C** Fair

3. (C) China  
(I) Italy  
(T) Taiwan

4. Prices current at time of article production and do not include shipping, where applicable.

# A gem of a Jewelry Chest

With elegance befitting its shimmering contents, this spacious case will become a treasured dressing-table accessory.







## SKILL BUILDER

### Book-match 'em, Danno

Create distinctive mirror-image grain patterns with book-matching. The process involves resawing a board, laying the pieces open like the pages of a book, then edge-joining the two halves to create a panel with a symmetrical pattern, *for right*.

When selecting material for a book-matched panel, look for distinctive grain that will make an interesting pattern. Also, the blank must be more than twice as thick as the glued-up panel, to allow for the saw kerf and planing of the completed panel. Joint the edge that will be the joint line; then resaw the blank down the center, *near right*. Glue the two halves together with the sawn faces up, aligning the grain patterns at the joint line, *for right*.

After the glue dries, plane the panel to thickness, and trim it to finished size if needed, keeping the joint line centered on the panel's width.



Mark a line down the center of one edge. Cut carefully to minimize cleanup of the sawn faces that could change the pattern match.



Open the resawn blank like a book. Align the grain pattern across the joint line, and glue the two halves together.

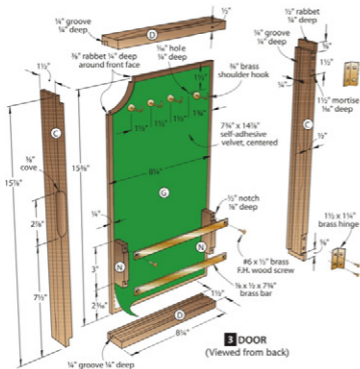

### 4 RING HOLDER SIDE SECTION VIEW

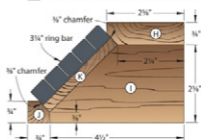

8 Apply glue to the rabbets on the door sides (C) and to the middle 3" only along the top and bottom of the door panel (G). Then assemble and clamp the panel, door sides, and door top and bottom (D) [Drawing 3, Photo A]. Finish-sand the case and door, using progressively finer grits from 120 to 320.

### Make the ring thing next

1 Cut a  $3/4 \times 3 1/2 \times 7 3/4$ " blank for the ring holder top (H) and front (J). **Quick Tip!** Rout one wide piece to make narrow parts. Starting with a blank  $3 1/2$ " wide allows safer routing for parts H and J. (The  $3 1/2$ " width assumes a  $1/8$ " kerf. If

## CLAMP DOWN TO SQUARE IT UP



**B** When gluing the top (H) to the ring-holder sides (I), clamp the pieces to your bench. Check both sides for square to the benchtop.

## AVOID SHOWING SUPPORT

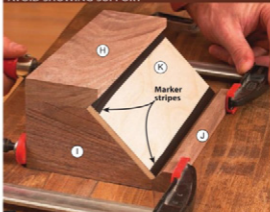

**C** Draw black marker stripes about  $\frac{1}{8}$ " wide on the front of the support (K) to keep the plywood from showing behind the ring bar.

your tablesaw blade cuts a different-width kerf, adjust the width of the blank accordingly.) To make the parts, rout  $\frac{3}{8}$ " chamfers along both long edges of the blank, and then rip the blank to width for part H. The cut-off piece becomes part J [Drawing 4].

**2** Cut the ring-holder sides (I) to shape [Drawing 4]. Dry-fit the ring-holder sides, top (H), and front (J) together, and cut the support (K) to width to fit between the top and front.

**3** Apply glue to the top edges of the ring-holder sides (I), and clamp the top (H) in place [Photo B].

**4** Glue and clamp the ring-holder front (J) to the H/I assembly, and glue the support (K) in place [Photo C]. Finish-sand the ring-holder assembly (H-K), except for the face of K.

## Add the top, bottom, and feet

**1** Cut the trim top and bottom (L) and feet (M) to size.

**2** Using a table-mounted router, form a  $\frac{3}{8}$ " cove along both ends and the front edge of the top and bottom (L) [Drawing 1].

**3** Change to a  $\frac{1}{4}$ " cove bit, and rout a cove on the back and inside edges of each front foot (M) and on the the front edge of each rear foot [Drawings 5, 6].

**Quick Tip!** Check your footing. To ensure that you rout the correct edges of the feet, lay the bottom (L) facedown on your bench and position a foot at each corner. Then mark the inside and back edges of each foot.

**4** Change to a 45° chamfer bit in your router, and rout a  $\frac{1}{4}$ " chamfer on the front and outside edges of each front foot (M) and only the outside edge of each back foot (M) [Drawings 5, 6].

**5** Glue and clamp the feet (M) to the bottom (L) [Drawing 6], positioning the straight edge of the back feet flush with the back edge of the bottom.

**6** Finish-sand the top (L) and bottom assembly (L/M). Then glue and clamp the top and bottom assembly to the case (A/B/E/F), centered side-to-side and flush at the back [Drawing 1].

**7** Apply glue to the bottom edges of the ring-holder sides (I), and glue the ring-holder assembly (H-K) into the case [Drawing 1].

## Take care of door details

**1** Cut the spacer blocks (N) to size, and rout or chisel the notches in them for the brass bars [Drawing 3]. Mask the backs of the spacers and the area where they glue to the door sides (C) [Photo D].

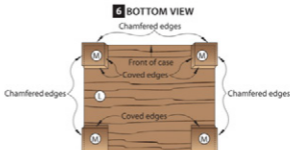
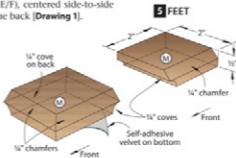

## SKILL BUILDER

### Dealing with the brass

Brass, a soft alloy of copper and zinc, works easily and polishes to a golden luster, making it an ideal metal to accent woodworking projects. You can buy brass at craft and hobby shops, many hardware stores, and from online metals dealers as thin sheets, bar stock, tubing, solid rods, and other shapes.

Here are some helpful tips for making the brass bars for the jewelry case:

■ **Prevent scratches.** Flat brass often comes with a plastic protective sheet.

Leave it in place for cutting and drilling. If your bar stock doesn't have protective covering, apply painter's tape. When gripping brass stock in a vise, wrap it with paper or rags for further protection.

■ **Cut with a hacksaw.** Brass cuts easily with a 32-tooth-per-inch hacksaw blade. Woodworking handsaws with hardened, fine teeth will cut brass, but they may dull quickly. After sawing, file or sand the cut end smooth.

■ **Centerpunch before drilling.** Lay out hole locations accurately, and punch-mark the centers so the drill won't skid around and mar the surface. Fluted or Weldon-style countersinks work well on brass.

■ **Polish and protect.** Polish the bars with progressively finer sanding sponges from 220 to 400 grit. For a shinier finish, continue polishing with 600-grit, 1200-grit, or finer, wet-or-dry sandpaper. Spray a light coat of clear lacquer onto the bars to protect them from tarnish and fingerprints. (We used satin lacquer.)



### SAVE SPOTS FOR THE SPACERS

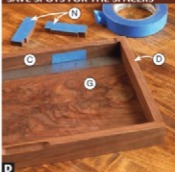

Mask off the glue surfaces for the spacer blocks (N); finishing the door and applying the velvet is easier with them unattached.

### ONE BLANK, TWO BLOCKS



For safer handling, mark the catch blocks on one blank. Bandsaw the blocks off the blank, cutting outside the line, and sand to the line.

**2** Cut two pieces of  $\frac{3}{8}$ " brass bar stock to length. Lay out, drill, and countersink a  $\frac{3}{8}$ " mounting hole centered  $\frac{3}{8}$ " from each end [Drawing 3]. See the **Skill Builder** above for tips on working with brass.

**3** Position the hinges in the mortises on the door side (C), and mark and drill the screw holes. Then, do the same on the case side (A) [Drawings 1, 3]. Attach the hinges to test the door fit, and then remove them.

**4** Cut a  $\frac{1}{2}$ "x2"x3" blank for the catch blocks (O). Lay out the two blocks on opposite corners of the blank [Drawing 7], and then drill the holes for the strike plate and catch [Photo E]. Cut the catch blocks from the blank, finish-sand them, and glue them to the door and case [Drawing 1]. The block for the magnetic catch glues to the case.

### Now you need two drawers

**1** Cut the drawer fronts and backs (P), sides (Q), and bottoms (R) to size [Drawing 8].

**2** With a tablesaw and dado set, or a table-mounted router, form the  $\frac{1}{4}$ " rabbets in the front and back (P) and sides (Q) [Drawing 8].

**3** Drill a  $\frac{3}{8}$ " hole centered on each drawer front (P) to accept a decorative brass knob.

**4** Glue and clamp the drawers (P-R), checking for square. After the glue dries, rout a  $\frac{1}{8}$ " rabbet  $\frac{1}{2}$ " deep along the front bottom edge of each drawer to make a shadow line [Drawing 8]. Finish-sand the drawers.

### Time for final assembly

**1** Finish-sand any parts as necessary. Apply a clear finish to the case assembly, door (C/D/G), drawers (P-R), and spacer blocks (N). (We applied three coats of satin polyurethane, buffing with 320-grit sandpaper between coats.)

**2** Cut and apply self-adhesive velvet to the inside of the door panel (G), the inside of the back (F) above the ring holder, and the inside of the drawer bottoms (R) [Drawings 1, 3, 8].

**3** Remove the masking tape, and glue the spacer blocks (N) to the inside of the door sides (C). Drill  $\frac{3}{8}$ " pilot holes into the spacer blocks, and attach the brass bars [Drawing 1]. Screw the strike plate to the catch block (O) on the door, and press the magnetic catch into the catch block on the case. Then reinstall the hinges on the door.

**4** Cut a piece of cardboard to  $1\frac{1}{2}$ "x7 $\frac{3}{4}$ ". Mark the spacing for the four hooks along one edge [Drawing 3]. Position the cardboard spacing guide inside the door along the top, and drill pilot holes for the hooks [Photo F]. Repeat this for the case hooks; then screw in the hooks.

## DRILL HANGER-HOOK HOLES



**F** When you drill pilot holes for the shoulder hooks, wrap a strip of painter's tape around the bit  $\frac{1}{8}$ " above the tip to serve as a depth stop.

## Cutting Diagram

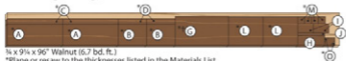

$\frac{1}{2}$  x  $9\frac{1}{4}$  x  $96"$  Walnut (6.7 bd. ft.)

\*Plane or resaw to the thicknesses listed in the Materials List.  
†If book-matching panel, resaw from  $1\frac{1}{4}$ "-thick material.

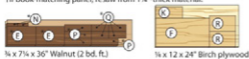

$\frac{1}{4}$  x  $7\frac{1}{8}$  x  $36"$  Walnut (2 bd. ft.)

$\frac{1}{4}$  x  $12$  x  $24"$  Birch plywood

## 7 CATCH BLOCKS

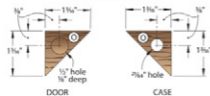

DOOR

CASE

**5** Cut the padded ring bar to length to fit in the case, spray adhesive on the back of it, and press it onto the ring-holder support (K).

**6** Attach a brass knob to each drawer front (P), and slide the drawers into the cabinet. Finally, attach the door hinges to the cabinet.

Written by **Larry Johnston** with **Kevin Boyle**  
Project design: **Jeff Metz**  
Illustrations: **Roxanne LeMoine; Lorna Johnson**

## Materials List

Part	FINISHED SIZE			Matl. Qty.
	T	W	L	
<b>Case and door</b>				
A* case sides	$\frac{1}{2}$ "	6"	16"	W 2
B* case top/bottom	$\frac{1}{2}$ "	6"	81 $\frac{1}{2}$ "	W 2
C* door sides	$\frac{1}{2}$ "	11 $\frac{1}{2}$ "	15 $\frac{1}{2}$ "	W 2
D* door top/bottom	$\frac{1}{2}$ "	11 $\frac{1}{2}$ "	81 $\frac{1}{2}$ "	W 2
E shelves	$\frac{1}{2}$ "	5 $\frac{1}{2}$ "	81 $\frac{1}{2}$ "	W 2
F case back	$\frac{1}{4}$ "	85 $\frac{1}{2}$ "	151 $\frac{1}{2}$ "	BP 1
G door panel	$\frac{1}{2}$ "	85 $\frac{1}{2}$ "	151 $\frac{1}{2}$ "	W 1
<b>Ring holder</b>				
H* top	$\frac{3}{8}$ "	2 $\frac{1}{2}$ "	7 $\frac{1}{2}$ "	W 1
I sides	$\frac{3}{8}$ "	2 $\frac{1}{2}$ "	4 $\frac{1}{2}$ "	W 2
J* front	$\frac{3}{8}$ "	$\frac{3}{4}$ "	7 $\frac{1}{2}$ "	W 1
K** support	$\frac{1}{4}$ "	3 $\frac{1}{4}$ "	7 $\frac{1}{2}$ "	BP 1
<b>Trim</b>				
L top/bottom	$\frac{1}{2}$ "	81 $\frac{1}{2}$ "	10"	W 2
M feet	$\frac{1}{2}$ "	2"	2"	W 4
N spacer blocks	$\frac{1}{8}$ "	$\frac{3}{4}$ "	3"	W 2
O* catch blocks	$\frac{1}{2}$ "	1 $\frac{1}{4}$ "	1 $\frac{1}{4}$ "	W 2
<b>Drawer</b>				
P fronts/back	$\frac{1}{2}$ "	17 $\frac{1}{2}$ "	7 $\frac{1}{2}$ "	W 4
Q sides	$\frac{1}{4}$ "	17 $\frac{1}{2}$ "	5"	W 4
R bottoms	$\frac{1}{4}$ "	41 $\frac{1}{2}$ "	7 $\frac{1}{2}$ "	BP 2

\*Parts initially cut oversize. See the instructions.  
\*\*Part width cut to fit. See the instructions.

**Materials key:** W—walnut, BP—birch plywood.  
**Supplies:** #6-1/2" brass flathead wood screws, 1x1/2" brass bar stock, 13x11/4" brass hinges (2), 1/2" brass shoulder hooks (8).  
**Blade and bits:** dado set; 1/4" and 3/8" chisel, 1/4" straight, 45° chamfer router bits.

## Source

**Velvet, ring bar, knobs, catch:** Black self-adhesive velvet, 12x24", item 34656, \$9.29 (also available in red, item 1047); green, item 10489; and blue, item 10497; black padded ring bar, 31/4x24", item 35248, \$22.49 (also available in red, item 32675; green, item 39860; and blue, item 32975); 1/4" brass knob, item 35451, \$3.59; 3/4" round magnetic catch, package of 4, item 29272, \$6.29. Rockler, 800-279-4441 or rockler.com.

## 8 DRAWER

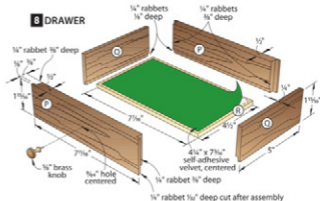

# Turn a Super Scooper



I scream! You scream! We all scream for fun, practical turning projects! Well, here's one: an ice cream scoop you can turn in an evening, and enjoy every sundae.



## 1 Prepare the template and blank

**Tools:** Crafts knife, drill press.  
**Speed:** 750 rpm

Photocopy the full-size template from the *WOOD Patterns* insert, and attach it to a piece of light cardboard with spray adhesive. Cut out the handle profile with a crafts knife.

Cut a 2x2x6" turning blank. (We used pink ivory in the photos throughout

this article. Any hard, tight-grained wood will do.) Draw diagonal lines across both ends of the blank, and punch the centers where the lines cross.

Using a brad-point bit, drill a 3/8" hole 1 1/4" deep centered on the scoop end of the handle, as shown at right. Drill a 1/2" hole about 3/8" deep centered on the other end—just enough to make a dimple to start the drive-center point.



## 2 Round the blank, lay out the profile

**Tools:** Lathe drive center, cone tail center, 3/8" spindle roughing gouge, outside calipers, template.  
**Speed:** 700 rpm

Install a spur drive center and a revolving cone tail center on your lathe. Mount the blank by hand to ensure it clears the cone center, and engaging the drive center in the shallow hole.

Position the tool rest so the gouge will contact the blank just above center. Turn the blank by hand to ensure it clears the tool rest. Then, start the lathe, and round the workpiece to 1 1/4" diameter.

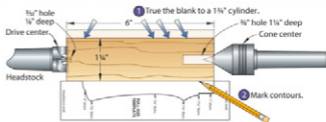

Lay the template on the tool rest against the rounded blank, aligning the end of the tenon on the template with the tailstock end of the blank. With the

lathe running at a slow speed, hold a pencil against the blank at each template arrow, and scribe a circle around the blank at each point.

### 3 Turn the tenon, fit the ferrule

**Tools:** Parting tool, outside calipers,  $\frac{1}{8}$ " skew or square-end scraper.

**Speed:** 1,000 rpm

At the second mark from the tailstock end, cut in with a parting tool on the tailstock side of the line to make a 1"-diameter gauging cut. See the **Shop Tip**, bottom.

Turn the tenon to size. Work toward the finished diameter in small increments, testing the ferrule's fit frequently, until the ferrule fits snugly over the tenon, as shown in the photo at right.

Apply five-minute epoxy or cyanoacrylate adhesive to the tenon, and slide on the ferrule. Clean off any squeeze-out, and allow the adhesive to cure.

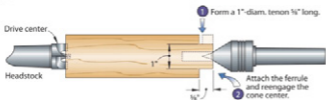
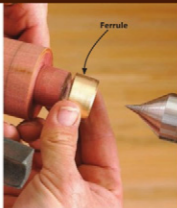

### 4 Shape the handle

**Tools:** Parting tool,  $\frac{1}{8}$ " spindle gouge, outside calipers.

**Speed:** 1,500 rpm

Make the two  $\frac{1}{8}$ "-diameter and one  $\frac{1}{16}$ "-diameter gauging cuts where indicated in the drawing.

With the spindle gouge, shape a smooth curve between the gauging cut nearest the ferrule and the ferrule, photo at top. Turn the surface of the blank flush with the ferrule surface.

Cutting from the headstock side, make a relief cut to the bottom of the  $\frac{1}{16}$ " gauging cut. This creates space to move

the gouge when shaping the sweeping curve of the handle.

Next, form a smooth curve between the major diameter at the tailstock end and the  $\frac{1}{16}$ " gauging cut, bottom photo.

Working from the  $\frac{1}{16}$ " gauging cut at the headstock end, shape the curve toward the  $\frac{1}{8}$ " gauging cut.

Blend the contours into each other to create a smooth, continuous curve between both major-diameter points.

**Quick Tip! Trust your feelings.** Stop the lathe and run your hand over the handle; you can feel high or low spots easier than you can see them.

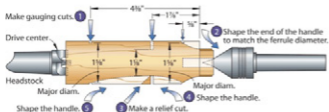
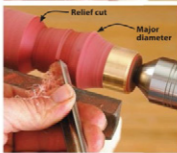

### SHOP TIP

#### Gauge diameters on the fly

A gauging cut, made by cutting in with a parting tool, helps you lay out a turning by establishing specified diameters at key points. To make gauging cuts for the tenon and other points along the scoop handle efficiently and accurately, open an outside calipers to the specified diameter. Use a calipers thinner than the width of your parting-tool kerf. Then, rest the open end of the calipers against the turning as you cut in. When you reach the correct diameter, the calipers will slip over the turning.

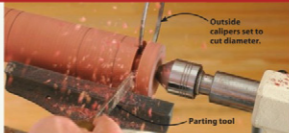

## 5 Go to the end

**Tools:** Parting tool,  $\frac{1}{8}$ " spindle gouge,  $\frac{1}{8}$ " skew, outside calipers.

**Speed:** 1,500 rpm

Make a gauging cut at the headstock end of the handle. Clear away waste between the gauging cut and the drive center.

Using the spindle gouge, form the handle end, as shown in **Steps 1-3**.

With the parting tool, cut in to form a tenon about  $\frac{1}{4}$ " in diameter. Begin to

shape the headstock-end bead on the tenon with the skew, leaving a connection of about  $\frac{1}{8}$ ".

Sand the handle with progressively finer grits of sandpaper, working from 100 to 400. As you sand the handle, keep the abrasive moving constantly along the turning axis to minimize circumferential scratches. **Quick Tip!** Go straight at the end. After sanding with the finest grit, turn off the lathe,

and sand in the direction of the grain. This eliminates any remaining sanding marks going around the handle.

At the tailstock end, cut straight in with the parting tool, flush with the end of the ferrule. Cut in as far as you can without hitting the cone center, as shown in the *bottom* photo.

Complete the bead at the headstock end with the skew chisel, parting the handle off the lathe.

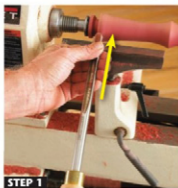

- 1 Make gauging cut, and remove waste.
  - 2 Roll the bottom of the handle.
  - 3 Make a cleaning cut.
  - 4 Form the bottom of the handle and part it from the blank.
- Headstock  
Drive center



## 6 Almost dessert time

Trim away the ridge around the hole at the end of the handle with a crafts knife, and sand the ends of the handle.

Mask off the ferrule with painter's tape. Drive a 3" screw into a piece of scrapwood, and place the hole in the handle over it. Apply a finish to completely seal the wood. (We used three coats of gloss polyurethane from a spray can, sanding to 320 grit between coats.)

Mix five-minute epoxy adhesive, and apply it in the handle hole with a toothpick. Press the scoop tang into the hole, and wipe away any adhesive squeeze-out. While the epoxy cures, go to the ice-cream shop, and stock up so you can try out your handwork. 🍦



### Source

**Ice cream scoop kit:** Brass scoop and ferrule, item 29848, \$10.99 plus shipping; chrome scoop and ferrule, item 22940, \$12.99 plus shipping, Rockler, 800-279-4441 or rockler.com

Written by **Larry Johnston** with **Jeff Mertz**  
Project design: **Jeff Mertz**  
Illustrations: **Roxanne LeMoine; Lorna Johnson**

# Shop-Proven Products

These woodworking wares passed our shop trials.

## About our product tests

We test hundreds of tools and accessories, but only those that earn at least three stars for performance make the final cut and appear in this section. Prices are current at the time of article production and do not include shipping, where applicable.

### SawStop safety available in a sub- $\$2,000$ saw

Nearly a decade after first demonstrating its innovative tablesaw blade-brake safety feature, SawStop has brought that technology to a lower-priced unit. Like the  $\$3,000$  cabinet-style saw, this contractor-style 10" saw with riving knife has the same skin-sensing blade brake that prevents serious injury. Its 110-volt, 1½-hp motor, heavy-duty cast-iron trunnions, and effective dust collection perform as well as any contractor saw we've tested. I tried both the aluminum (shown) and Biesemeyer-style rip fences and got good results with each; I recommend the cast-iron extension wings over the stamped steel.



—Tested by Doug Hicks  
Doug is a former shop teacher and woodworking magazine editor.

#### Contractor-Style Tablesaw

Performance ★★★★★  
Price \$1,599 – 1,999  
SawStop  
866-729-7867; sawstop.com



### Make quick Euro-hinge bores with this jig

The Easy Bore Hinge-Boring Jig takes all the guesswork out of aligning and drilling the holes for European-style cup hinges. I simply selected the adjustable spacing bumpers inside the jig for the correct offset from the stile edge, placed the jig onto the door, and locked it in place. Each of the hex-head bolts on the jig turns a drill bit inside: the center one bores the 35mm cup hole, and the others the 8mm holes for plastic screw bushings. Install the included socket driver in a drill and bore all three holes. Or, to drill holes for standard screws instead of bushings, simply tap the outer screw bits to indent the wood, remove the jig, and drill with the appropriate bit. It's remarkably simple and accurate.



—Tested by Matt Seier  
Matt builds custom furniture for a living.

#### Easy Bore Hinge-Boring Jig

Performance ★★★★★  
Price \$180  
Sommerfeld Tools For Wood  
888-228-9268; sommerfeldtools.com

### Up-front controls make this slider easy to use

I use a sliding miter saw every day, so I appreciate what Bosch has put into its new 10" slider. With the bevel lock up front, I no longer have to reach to the back of the saw to make those adjustments. The miter and bevel stops proved dead-on, even at its maximum 12" width, and the scales are adjustable should it lose its alignment. It has all the power I needed to cut thick hardwoods, and without the annoying start-up lurch so common to miter saws. Even though the dust bag is porous, I was impressed with how much sawdust it actually gathered.



—Tested by Dave Fish  
Dave is a trim carpenter and cabinetmaker.

#### 10" Sliding Compound Miter Saw, #4405

Performance ★★★★★  
Price \$480  
Bosch  
877-267-2499; boschtools.com







## Two bevels prove better than one on no-burn bits

Freud has solved one of the problems woodworkers have battled for years. Straight router bits—even new ones—tend to burn wood if they spin in one place for even a second or two, such as at the end of a stopped dado. These new double-bevel carbide bits never did that because a relief bevel ground on the back half of the carbide cutting edge helps clear chips quicker, reducing the heat buildup that causes burns. And a nice bonus is the cleaner, smoother edges they leave. I compared them to several new standard bits, all of which left rippled edges to varying degrees. The Freud Double-Grind bits left no ripples. Freud has replaced all its straight bits with this technology, in diameters from  $\frac{1}{8}$ " to  $1\frac{1}{4}$ ".



—Tested by Matt Spier  
Matt builds custom furniture for a living.

### Double-Grind Straight Router Bits

Performance ★★★★★  
Price \$18-\$46  
Freud  
800-334-4107; freudtools.com

# CHOOSE THE TOOL THAT WORKS FOR YOU

AND YOU'LL SAVE TIME AND MONEY.



## Material Estimator™

### Materials Estimating Calculator

With the Material Estimator you can quickly and easily calculate Yards, Feet, Inches, Fractions and Meters and material costs and allowances to get exactly the materials you need. Prevent estimating errors and save time and money. **Model 4019**

## Construction Master® Pro

### Advanced Feet-Inch-Fraction Construction-Math Calculator

It features more powerful built-in solutions, in addition to those found in the Measure Master Pro. The perfect tool if your woodworking passion includes projects such as remodeling or adding a room. It even provides Angles for compound miters. **Model 4065**

## Home ProjectCalc®

### Do It Yourself Project Calculator

Simplify your home improvement projects with this easy-to-use calculator. Built-in function keys let you quickly and accurately find material requirements for paint, concrete, tiles, wallpaper and carpet. **Model 8510**

To see how these tools can help you today, go to

[www.calculated.com](http://www.calculated.com)

WD 609

For a dealer near you call 1-800-854-8075

4840 Hytech Drive, Carson City, NV 89706 • 1-775-885-4900 Fax: 1-775-885-4949



Pinnacle is defined by Webster's as *the highest point of development or achievement*. The latest offering of marking and measuring tools that bear the Pinnacle® name have certainly lived up to this definition. Every detail of these Pinnacle® tools was engineered with one thing in mind: to provide woodworkers with tools that empower them. Pinnacle® tools are available exclusively at Woodcraft.

Made in The USA



### Pinnacle® Woodworking Rules

148975 (A) 6"  
148976 (B) 12"  
148977 (C) 24"  
148978 (D) 36"



### Pinnacle® Precision Square - 147630

Craft higher quality, more professional cabinetry and furniture with the Pinnacle® Precision Square. Accuracy of this machined aluminum square is better than .001" over the entire 8" x 12" size. Includes a custom fitted MDF case that not only holds the square, but also protects it when not in use. Wall mount the case to keep your square handy for easy access!

## PROFESSIONAL QUALITY TOOLS™

Available Exclusively At Woodcraft!

For A Free Catalog Or To Find Your Local Woodcraft Store, Visit [woodcraft.com](http://woodcraft.com)  
Or Call 800-225-1153. [www.woodcraft.com/pinnacle](http://www.woodcraft.com/pinnacle) WD.aspx

## Shop-Proven Products

### For \$30 you can make any miter gauge accurate

I've got several miter gauges in my shop, including a 40-year-old Rockwell that doesn't have a pointer anymore—long since lost—so I could never be certain of its accuracy. MiterSet has returned value to that gauge by allowing me to precisely set miter angles without using the gauge's scale.

This handy little 6" square of 3/4"-thick, laminate-topped Baltic birch plywood has a 3/16"x3/4" miter bar groove down the center. Precisely drilled, symmetrical holes on each side of the slot indicate 5° increments and accept two metal pins. To use the MiterSet, simply place one pin into the 0° hole on one side, and the other pin into the desired angle setting on the other side. Slide your loosened miter-gauge head against both pins, and then tighten the knob. To obtain angles not divisible by five—22 1/2°, for example—insert the stepped fine-adjusting bar between the head and the pins. The notches on the bar help you set any angle to within 1/4°.

How accurate is the MiterSet? I used it set to 22 1/2° angles in my pointerless Rockwell gauge (below), and then cut an octagonal frame (eight pieces with 22 1/2° miters on each end). They fit together without the slightest gap.

—Tested by Dean Fiene  
Dean has been a woodworker for more than 40 years.



#### MiterSet

Performance ★★★★★  
Price \$30  
Richard L. Pattee  
209-835-1626; miteraset.com



## "THE INVISIBLE FASTENER"

GREX 23 GAUGE HEADLESS PINNERS. UP TO 2" PINS INTO RED OAK.  
IN THE SHOP AND ON-SITE. FROM FINE WORK TO CROWN AND BASE.

SERIOUS ABOUT  
YOUR WORK ?

SERIOUS ABOUT  
YOUR TOOLS ?

MAKE SURE  
IT'S A GREX



GREX  
23 GA. HEADLESS PINNERS

Changing ideas into solutions.

Alhambra, CA • 888-4GREXCO • info@grexusa.com  
Chesham, ON • 905-638-4887 • info@grexcanada.com  
www.grexusa.com



## DON'T LET FUNGUS EMBARRASS YOU!



Nail it! with

FUNGI-NAIL BRAND

#1 Anti-fungal Available Without a Prescription

- ✓ Guaranteed Effective
- ✓ Trusted for over 25 Years
- ✓ Maximum Strength Formula
- ✓ No Side Effects

#1  
Pharmacist  
Recommended

FREE!

Nail Care set and  
brochure on how to NAIL  
your fungus!  
Call 1-800-824-4894  
or visit [www.funginail.com](http://www.funginail.com)

