

**TOP
NEW TOOLS
FOR 2010**
p.68

WOOD

The World's Leading
Woodworking Resource

Build this Classic Barrister's Bookcase

73
Time-saving
Tips Inside!



Plus

Great Last-minute Gifts

- Jewelry Box p.58
- Chip & Dip Server p.50
- Kid's Puzzle p.64

11
Router Secrets
Revealed!

Display until January 19, 2010



\$6.99 U.S.



Grizzly Industrial®

PURVEYORS OF FINE MACHINERY®, SINCE 1983!

16" x 43" SWIVEL-HEAD WOOD LATHE with Digital Readout

- Motor: 2 HP, 110V, single-phase
- Precision ground cast iron bed & cast iron legs
- Swing over bed: 16"
- 1" x 8 TPI RH headstock spindle
- MT#2 spindle & tailstock tapers
- 10 speeds, 600-2400 RPM
- Approx. shipping weight: 308 lbs.

SPINDLE TACHOMETER w/DIGITAL READOUT



G0462
REG. \$495⁰⁰
Sale \$445⁰⁰

FREE SHIPPING
REG. \$89

10" WET SHARPENING SYSTEM

- Wheel speed: 90 RPM
- 220 grit grinding wheel
- Grinding wheel size: 10" dia. x 2" wide
- Leather stropping wheel size: 8" dia. x 1 1/4" wide
- Includes universal jig, angle guide & polishing/honing paste
- Approx. shipping weight: 42 lbs.

MADE IN GERMANY!



T10010
REG. \$189⁰⁰
Sale \$159⁹⁵

10" JOINTER/PLANER COMBO

- Motor: 2 1/2 HP, 220V, single-phase, 3400 RPM
- Jointer table size: 12 1/2" x 40 3/8"
- Cutterhead knives: 2 HSS
- Cutterhead speed: 6500 RPM
- Planer table size: 9 3/4" x 23 1/4"
- Planer feed rate: 16 FPM
- Approx. shipping weight: 378 lbs.
- Max depth of cut: Jointer - 1/8" Planer - 3/16"
- Max width of cut: Jointer - 10 1/4" Planer - 9 7/32"

FREE SAFETY PUSH BLOCKS



G0675
REG. \$1195⁰⁰
Sale \$995⁰⁰

FREE SHIPPING
REG. \$89

THE ULTIMATE 10" LEFT-TILT CONTRACTOR STYLE TABLE SAW

- Motor: 2 HP, 110V/220V, single-phase
- Precision ground cast iron table & wings
- Table size: 27" x 39 3/4"
- Arbor: 5/8"
- Cutting capacity: 3 1/2" @ 90°, 2 1/2" @ 45°
- Rip capacity: 30"
- Approx. shipping weight: 317 lbs.

MADE IN ISO 9001 FACTORY

SHOP FOX® ALUMA-CLASSIC FENCE



G0576 ONLY \$775⁰⁰

FREE SHIPPING
REG. \$89

10" TILTING ARBOR SUPER HEAVY-DUTY TABLE SAW

- Motor: 3 HP, 220V, single-phase, TEFC
- Precision ground cast iron table
- 2 solid cast iron extension wings
- Table size w/wings attached: 27" x 40"
- Arbor: 5/8"
- Cutting capacity: 8" L, 26" R
- Standard & dado table inserts
- Approx. shipping weight: 420 lbs.

SHOP FOX® CLASSIC FENCE



G1023S REG. \$1075⁰⁰
Sale \$895⁰⁰

FREE SHIPPING
REG. \$89

10" LEFT-TILT CABINET TABLE SAW with Riving Knife & Extension Rails

- Motor: 3 HP, 220V, single-phase, TEFC
- Precision ground cast iron table & cast iron trunnions
- Table size w/extension: 27" x 63"
- Arbor size: 5/8"
- Arbor speed: 4300 RPM
- Rip capacity: 50"
- Approx. shipping weight: 644 lbs.

QUICK RELEASE SEE-THRU GUARD & RIVING KNIFE



G0691 REG. \$1350⁰⁰
Sale \$1215⁰⁰

FREE SHIPPING
REG. \$139

14" INDUSTRIAL RESAW BANDSAW

MADE IN ISO 9001 FACTORY

- Motor: 2 HP, 110V/220V, single-phase, TEFC
- Precision ground cast iron table size: 19 1/4" x 14 1/8"
- Table tilt: 8" L, 45" R
- Max. cutting height: 10"
- Blade size: 106" L x 3/8" - 3/4" W
- Blade speed: 3000 FPM
- Approx. shipping weight: 284 lbs.



G0457
REG. \$895⁰⁰
Sale \$795⁰⁰

FREE SHIPPING
REG. \$89

17" HEAVY-DUTY BANDSAW

- Motor: 2 HP, 110V/220V, single-phase, TEFC
- Precision ground cast iron table size: 17" square x 1 1/2" thick
- Table tilt: 10" L, 45" R
- Max. cutting height: 12"
- Blade size: 131" L x 1/2" - 1" W
- Blade speeds: 1700 & 3500 FPM
- Approx. shipping weight: 342 lbs.

MADE IN ISO 9001 FACTORY



G0513
REG. \$795⁰⁰
Sale \$715⁰⁰



\$89
ANYWHERE IN THE U.S. IN 2 WEEKS

1 1/2 HP 2 STAGE CYCLONE DUST COLLECTOR

Check It Out!

- Motor: 1 1/2 HP, 110/220V, single-phase, TEFC, 3450 RPM
- Air suction capacity: 866 CFM
- Static pressure: 2.08"
- Intake port: 6" • Impeller: 13 1/2"
- Fully mobile w/built-in casters
- Overall dimensions: 38" W x 26" D x 68-1/2" H
- Approx. shipping weight: 193 lbs.



G0703
INTRODUCTORY PRICE \$825⁰⁰

New! BIG FEATURES IN A COMPACT SIZE!

\$89
ANYWHERE IN THE U.S. IN 2 WEEKS

11978



1-800-523-4777

TECHNICAL SERVICE: 570-546-9663 • FAX: 800-438-5901

3 GREAT SHOWROOMS!
BELLINGHAM, WA
MUNCY, PA
SPRINGFIELD, MO

Holiday Sale

GET REDUCED PRICES ON MANY ITEMS &
FREE SHIPPING ON OVER 200 MACHINES

NOVEMBER 2nd UNTIL DECEMBER 31st, 2009



GRIZZLY GIFT
CERTIFICATES TAKE
THE GUESSWORK
OUT OF GIVING!

6" PARALLELOGRAM JOINTER with Spiral Cutterhead

- Motor: 1½ HP, 110V/220V, single-phase
- Precision ground cast iron table size: 6" x 55½"
- Rabbeting capacity: ½" • Max. depth of cut: ½"
- Cutterhead speed: 4850 RPM
- Center mounted fence system: positive stops @ ±45° & 90°
- Built-in mobile base
- Approx. shipping weight: 362 lbs.

FREE SAFETY
PUSH BLOCKS



G0604X
ONLY \$650⁰⁰

FREE
SHIPPING
REG. \$89

8" JOINTER with 2 HP MOTOR

- Motor: 2 HP, 110V/220V, single-phase, TEFC
- Precision ground cast iron table size: 9¾" x 75"
- Rabbeting capacity: ½" • Max. depth of cut: ½"
- Cutterhead knives: 4 HSS
- Cutterhead speed: 5500 RPM
- Deluxe cast iron fence size: 38"L x 1¼"W x 4"H
- Approx. shipping weight: 558 lbs.



G0586
REG. \$695⁰⁰
Sale
\$575⁰⁰

\$139
ANYWHERE IN
THE U.S. FREE

FREE
SAFETY
PUSH
BLOCKS

8" JOINTER with Built-In Mobile Base

- Motor: 3 HP, 220V, single-phase, TEFC, 3450 RPM
- Precision ground cast iron tables size: 9" x 72½"
- Rabbeting capacity: ½" • Max. depth of cut: ½"
- Cutterhead speed: 5000 RPM
- Deluxe cast iron fence size: 35"L x 5"H
- Built-in mobile base
- Approx. shipping weight: 556 lbs.



G0656
REG. \$795⁰⁰
Sale \$715⁰⁰

\$139
ANYWHERE IN
THE U.S. FREE

FREE
SAFETY
PUSH
BLOCKS

12½" LEAN & MEAN PLANER

- Motor: 2 HP, 110V, single-phase
- Max. cutting height: 6"
- Feed rate: 32 FPM
- Knives: 2 double edged HSS
- Cutterhead speed: 10,000 RPM
- Top mounted return rollers
- Cuts per inch: 52
- Approx. shipping weight: 78 lbs.

INCLUDES
KNIFE SETTING
JIG & WRENCH

Hot!



G0505
REG. \$295⁰⁰
Sale
\$245⁰⁰

\$39
ANYWHERE IN
THE U.S. FREE

15" PLANER with Built-In Mobile Base

- Motor: 3 HP, 220V, single-phase
- Precision ground cast iron tables & wings
- Table size: 15" x 20"
- Max. cutting height: 8"
- Max. cutting depth: ½"
- Feed rate: 16 & 30 FPM
- Cutterhead speed: 5000 RPM
- Built-in mobile base
- Approx. shipping weight: 675 lbs.



HEAVY-DUTY CAST IRON CONSTRUCTION

G0453 REG. \$950⁰⁰
Sale \$850⁰⁰

FREE
SHIPPING
REG. \$139

20" EXTREME SERIES® PLANER with Spiral Cutterhead

- Motor: 5 HP, 220V, single-phase
- Precision ground cast iron table
- Table size with extensions: 20" x 55½"
- Max. cutting height: 8¾"
- Max. cutting depth: ½"
- Cutterhead speed: 5000 RPM
- Feed rate: 16 & 20 FPM
- Approx. shipping weight: 909 lbs.



MADE IN
ISO 9001
FACTORY

ADJUSTABLE BED ROLLERS

G1033X REG. \$2495⁰⁰
Sale \$2245⁰⁰

FREE
SHIPPING
REG. \$169

¾ HP SHAPER

with Router Bit Adapter

- Motor: ¾ HP, 110V, single-phase w/reversing switch
- Precision ground cast iron table size: 15¾" x 17¾"
- Spindle cap. under nut: 2¾"
- Spindle speed: 8900 RPM
- Spindle travel: ¾"
- Spindle dia.: ½"
- Spindle length: 3"
- Split fence design w/ sliding wood faces
- Approx. shipping weight: 172 lbs.



G0510Z REG. \$325⁰⁰
Sale \$295⁰⁰

Z-SERIES \$69
ANYWHERE IN
THE U.S. FREE

PROFESSIONAL SPINDLE SHAPER

- Motor: 5 HP, 220V, single-phase, TEFC
- Precision ground cast iron table size: 35½"W x 28"D
- Table counterbore: 7" x ½"D
- Spindle travel: 3¼"
- Spindle sizes: ¾", 1" & 1½" x 7 ½"L
- Max. cutter dia: 5¾"
- Spindle speeds: 3600, 5100, 8000 & 10,000 RPM
- Approx. shipping weight: 602 lbs.



Z-SERIES

G5912Z REG. \$2295⁰⁰
Sale \$1995⁰⁰

FREE
SHIPPING
REG. \$139

18" OPEN END DRUM SANDER

- Sanding motor: 1½ HP, 110V, single-phase
- Drum surface speed: 4000 FPM
- Conveyor feed rate: variable, 2-12 FPM
- Max. stock dimensions: 36" W x 4½" thick
- Min. board length: 6"
- Min. board thickness: ½"
- Sanding drum size: 4"
- Dust collection port: 2¼"
- Approx. shipping weight: 354 lbs.



STAND ALONE DUST
COLLECTION W/DUST BAG

G0458
ONLY \$950⁰⁰

FREE
SHIPPING
REG. \$89



grizzly.com®

24 HOUR ORDERING • OVER 12,000 PRODUCTS ONLINE!

RECEIVE A
FREE GIFT
WITH EVERY ONLINE
ORDER!
LIMITED
TIME OFFER

in this issue



28



64



20



54

PROJECTS

- 18 Shop Project: Shelf-pin Drilling Jig
- 28 Barrister's Bookcase
- 38 Flat-panel TV or Game Cabinet
- 50 Chip 'N' Dip Tray
- 58 Curvy Jewelry Box
- 64 Scrollsawn Barnyard Puzzle

SKILL BUILDERS

- 20 How to Install a Mortised Lock
- 54 Get the Max from Your Plunge Router

TOOLS & MATERIALS

- 24 Wise Buys: Spindle Sanders
- 68 10 Top New Tools for 2010
- 78 Shop-Proven Products

DEPARTMENTS

- 6 Sounding Board
- 8 Shop Tips
- 16 Shop Monkey
- 45 Annual Article Index
- 72 Ask WOOD
- 92 What's Ahead



38





68



50

This seal is your assurance that we build every project, verify every fact, and test every reviewed tool in our workshop to guarantee your success and complete satisfaction.



58



16

SHOW OFF THE GIFTS YOU BUILT

Before you wrap that handmade gift, take a few snaps of it and post them to the "Holiday Gifts 2009" photo gallery at woodmagazine.com/holiday2009.

Last year, Vilas and Cheryl Schroeder of Marinette, Wis., crafted this gorgeous 14' shuffleboard table as a present to their daughter, Sarah, and her husband, Chad.



LEARN TO BUILD CABINETS

Why pay big bucks for flimsy shop cabinets when you can build rock-solid ones for less? We'll even help. Go to woodmagazine.com/betterwoodworking, then search for "cabinet." There, you'll find nearly a dozen downloadable videos about cabinetmaking.



WHADDAYA KNOW ABOUT WALNUT?

Before you build the Barrister Bookcase project on page 28, learn all about walnut—and how to work with it—at woodmagazine.com. Just type "walnut" into the search box and click "Search."



HOME-THEATER WIRING, SIMPLIFIED

Whether you build the Flat-panel TV Cabinet project on page 38 or one of your own design, you'll need to connect it all and learn how to hide the wires. We've hooked up with the electronics experts at Crutchfield to teach you everything you need to know.

- Tips for Home A/V Cable Management woodmagazine.com/cables
- A Guide to Wall-mounting Your Flat-panel TV woodmagazine.com/flatpanel
- In-wall Wiring Guide woodmagazine.com/inwallwiring
- TV Connections woodmagazine.com/connect

Let your good taste show



ZAR® ULTRA MAX OIL MODIFIED WOOD STAIN interior formula applies easily and penetrates evenly to achieve a rich, uniform color. It is ideal for furniture, hardwood floors, woodwork and wood, metal or fiberglass doors.

Core/Shell Technology provides the deep tones of an oil-based stain with the low odor, fast drying and easy clean-up of a water-based stain.

In addition, the **Advanced Green Phase Resin Dispersion Technology** utilizes environmentally friendly resins that result in a VOC compliant product.

With its delicious new colors, Ultra Max Wood Stain gives you a great look that is also good for the environment.



For more information or a dealer near you visit www.ugl.com or call 1-800-272-3235.



We asked our staff:
What's your favorite hand tool?



Bevel-edged bench chisel. Nothing beats the feel of a super-sharp chisel slicing through wood and yielding just the result I'm looking for.



My Pfeil chisels. I can hone a razor's edge that doesn't disappear after the first cut into white oak.



Stanley utility knife. Besides cutting, it's a great finesse tool for applying minute amounts of glue to a repair, scraping small areas, and doing general clean-up.



Lee Valley Apron Plane. It's a small low-angle block plane that fits in an apron pocket so it's always handy.



The shop plane I built. It feels good in my hand, and works well for smoothing parts.

EDITOR-IN-CHIEF
BILL KRIER

Managing Editor
MARLEN KEMMET
Art Director
KARL EHLERS

Techniques Editor
BOB WILSON
Multimedia Editor
LUCAS PETERS

Design Editor
JEFF MERTZ

Production/Office Manager
MARGARET CLOSNER

Deputy Editor
DAVE CAMPBELL
Senior Design Editor
KEVIN BOYLE

Tool & Techniques Editor
BOB HUNTER

Multimedia Editor
CRAIG RUEGSEGER

Associate Art Director
GREG SELLERS

Administrative Assistant
SHERYL MUNYON

Photographers

JASON DONNELLY, SCOTT LITTLE, JAY WILDE

Contributing Illustrators **TIM CAHILL, LORNA JOHNSON, ROXANNE LeMOINE**

Technical Consultants **BOB BAKER, DOUG HICKS**

Contributing Craftsman **JIM HEAVEY**

Contributing Proofreaders **BABS KLEIN, IRA LACHER, JIM SANDERS**

SUBSCRIBER SERVICE

Go to woodmagazine.com/help or write to
WOOD magazine, P.O. Box 37439, Boone, IA 50037-0439

Publisher **MARK L. HAGEN**

ADVERTISING AND MARKETING

CHICAGO: 333 N. Michigan Ave., Suite 1500, Chicago, IL 60601

Marketing Manager **AMANDA SALHOOT**

Advertising Manager **JACK CHRISTIANSEN**

Direct Response Advertising Representative **LISA GREENWOOD**

Assistant **TIM BAARDA**

ATLANTA: Navigate Media

DETROIT: RPM Associates

Business Manager **JEFF STILES**

Consumer Marketing Director **TODD BIERLE**

Associate Director of Marketing-Newsstand **TOM DEERING**

Production Manager **SANDY WILLIAMS**

Advertising Operations Manager **JIM NELSON**

E-Commerce Manager **MATT SNYDER**

Vice President/Group Publisher **TOM DAVIS**

MEREDITH PUBLISHING GROUP

President **JACK GRIFFIN**

Executive Vice President **DOUG OLSON**

President of Consumer Magazines and

Chief Revenue Officer **TOM HARTY**

Finance & Administration **MIKE RIGGS**

Manufacturing **BRUCE HESTON**

Consumer Marketing **DAVID BALL**

Corporate Sales **MICHAEL BROWNSTEIN**

Meredith 360° **JEANNINE SHAO COLLINS**

Interactive Media **LAUREN WIENER**

Corporate Marketing **NANCY WEBER**

Research **BRITTA WARE**

Chief Technology Officer **TINA STEIL**

New Media Marketing Services **ANDY WILSON**

Direct Response and Travel **PATTI FOLLO**



President and Chief Executive Officer **STEPHEN M. LACY**

Chairman of the Board **WILLIAM T. KERR**

In Memoriam — **E.T. Meredith III (1933-2003)**

Our subscribers list is occasionally made available to carefully selected firms whose products may be of interest to you. If you prefer not to receive information from these companies by mail or by phone, please let us know. Send your request along with your mailing label to Magazine Customer Service, P.O. Box 37452, Boone, IA 50037-0452.

© Copyright Meredith Corporation 2009. All rights reserved. Printed in the U.S.A.

Retail Sales

Retailers can order copies of WOOD for resale
by e-mailing jennifer.buser@meredith.com



The facts are hard to ignore.

Titebond® III outperforms polyurethane glues.

Reference Guide

Glue comparison

What woodworkers need to know!

	Titebond III	Polyurethane Glues
Higher Bond Strength	✓	✓
Exterior Use - Waterproof	✓	
Easy Water Cleanup	✓	
Much Safer To Use	✓	
Shorter Clamp Time	✓	
No Foam - Less Mess	✓	
Shorter Open Time	✓	
Doesn't Stain Skin	✓	✓
Bonds Most Materials	✓	
Bonds Oily / Exotic Woods	✓	
Lower Cost - Better Value	✓	
Longer Usable Shelf Life	✓	

Woodworking Handbook 2008
p. 223



As the leader in wood glues, we want you to know the truth about polyurethane glue and woodworking. A straightforward comparison between Titebond® III Ultimate Wood Glue and polyurethane glue tells the story.

Titebond® III is THE ultimate choice for bonding wood to wood. Period.

For more information and a detailed comparison, please visit www.titebond.com/TBIIIvsPolyurethane

Made in the USA

Proud Sponsor Of

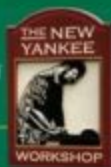

Sounding Board

Our bulletin board for letters, comments, and timely updates

Part of the bench, all the appreciation

My wife enjoys gardening and has turned our backyard into a beautiful park-like setting with several places to sit and enjoy the fruits of her labors. So when my son and I saw the tree bench in issue 190 (May 2009), we built it as a Mother's Day gift for her. Because we don't have a large tree in our yard, we built half the bench, added arm rests on the ends for stability, and placed it around a flowering crab-apple tree. She loves it.

—Scott Tibbels, Omaha, Neb.



Half-size rockers for half-pint youngsters

I wanted to make a child-size rocking chair for my niece's first child, born this past year, so I built a smaller version of the rocker in issue 183 (May 2008). I made each part exactly half the size of those in the original plan, with a few exceptions: I made the seat slats wider, beefed up the rail and slat tenons to about three-quarter scale, and gave the curved rockers a T-shape for a wider footprint. So far, I've made four chairs, two each in cherry and oak. Thanks for the inspiration.

—Mark Wroblewski, LaSalle, Ill.

How about the random-orbit sander as an innovation?

Might I suggest another tool for your list of woodworking innovations in the past 25 years: the random-orbit sander. About 21 years ago, I saw a dual-action pneumatic sander at my brother-in-law's autobody shop, and I said someone should invent a sander like that for woodworking. A few months later, I saw my first electric random-orbit sander made for wood. Now a regular user, I most likely would not be a cabinetmaker if it weren't for this tool because it turned the worst part of cabinet building into an acceptable, reasonably pleasant task.

—Tom Kurth, Alma, Mo.

Upon further reflection, Tom, we should have included these sanders. Although German-based Festool invented the electric random-orbit sander more than 25 years ago, ROSs weren't widely available in the U.S. until the late '80s. And we're with you about its time-saving performance: We won't work without one, either.

—WOOD magazine editors

I made the switch on my machines

Reading your review of router-table power switches (issue 189, March 2009) inspired me to replace the push-button switches on my stationary machines because they were all different and often hard to push the "off" buttons. So I replaced them with Grizzly's Safety Paddle Switch (#G8988, \$4; 800-523-4777, grizzly.com).



—Bill Tarleton, Lafayette, Calif.

HOW TO REACH US

For woodworking advice:

Post your woodworking questions (joinery, finishing, tools, turning, dust collection, etc.) on one of our online forums at woodmagazine.com/forums.

To contact our editors:

Send your comments via e-mail to woodmail@woodmagazine.com; or write to WOOD magazine, 1716 Locust St., LS-221, Des Moines, IA 50309.

Subscription assistance:

To notify us of an address change or to get help with your subscription, visit woodmagazine.com/service. Or write to WOOD magazine, P.O. Box 37439, Boone, IA 50037-0439. Please enclose your address label from a recent magazine issue.

To find past articles:

See our index at woodmagazine.com/index.

To order past issues and articles:

For past issues of WOOD magazine, special newsstand-only issues, or downloadable articles, go to woodmagazine.com/store. Some issues are sold out.

Updates to previously published projects:

For an up-to-date listing of changes in dimensions and buying-guide sources from issue 1 through today, go to woodmagazine.com/editorial.

INNOVATION XB

Introducing 3 New
JET® Tools Designed
Specifically for the
Serious Woodworker

- >> 20", 18" and 16" TSC™ Bandsaws
- >> 22-44 ODH™ Oscillating Drum Sander
- >> 17" XACTA-X™ Drill Press



**STRENGTH
REBORN.**

TRIANGULAR STABILITY CONTROL



The ALL-NEW JET® TSC™ Bandsaws are designed with a Triangular Frame to provide superior column rigidity that enables precision sawing.

**FINEST
FINISH.**



The ALL-NEW JET® 22-44 ODH™ Oscillating Drum Sander features a Drum Head that oscillates from left to right to eliminate workpiece streaking left by linear drum sanders.

**INSTANTLY
EXACT.**



The ALL-NEW JET® 17" XACTA-X™ Drill Press features an X-Shaped head mounted dual AC powered laser guide system for accurate cross point drilling.

THE AFTER THANKSGIVING

ALL TOOL 4 DAY SALE

OFFER GOOD:
Friday through Monday,
November 27-30, 2009

DON'T MISS YOUR
CHANCE TO SAVE!

SAVE
15%
ON HUNDREDS OF
TOOLS

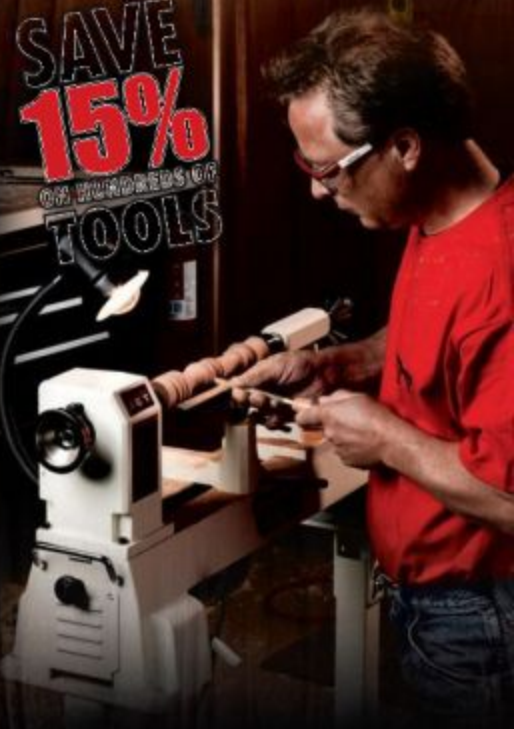

VISIT ANY QUALITY
JET OR POWERMATIC DEALER.

JETTOOLS.COM • POWERMATIC.COM

JET®

Visit Us Online At: www.jettools.com

©2009 WMH Tool Group, Inc. The color WHITE is a registered trademark of WMH Tool Group, Inc.

QUALITY | INNOVATION | SERVICE

Shop Tips

Helping you work faster, smarter, and safer

Poor man's bench vise

I wanted a vise on my secondary workbench, but didn't want to pony up the cash for another heavy-duty one like on my main workbench. So I built this low-dough bench clamping system to hold oversized boards. After installing T-track near the edge of my bench, I

drilled holes through 10" handscrew clamps, as shown below, to accommodate $\frac{1}{4} \times 2\frac{1}{2}$ " T-bolts. The star knobs lock the clamps along the T-track to accommodate different board widths and lengths.

—Ken Minnaert, Olympia, Wash.

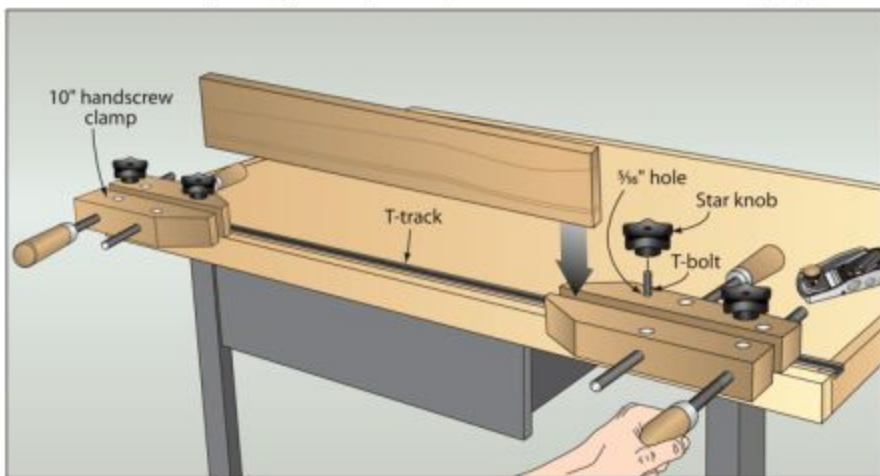

Speedy spindle gauge

While manually duplicating spindles on my lathe recently, I grew tired of constantly setting and resetting my calipers to check the various diameters along the workpiece. So I made this simple hardwood story board to speed up the process.

I drew a centerline on a scrap of hardboard and drilled holes of dimin-

ishing sizes with my Forstner bits. At the tablesaw, I cut to one side of the centerline, ripping the board in two and discarding the waste side. On the remaining board, I marked each half-circle with its diameter. By placing the desired-size hole over the spindle, I quickly check my progress at critical diameters.

—Byron Manthey, Hutchinson, Minn.

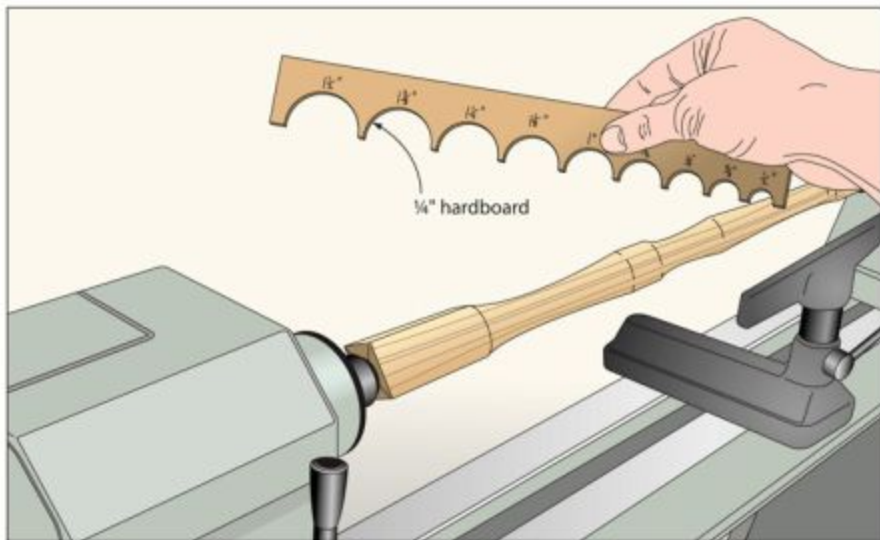

continued on page 10

The Top Tipster



Photo: Derek Pearson

Most of us would be honored to have a child named after us. But Dr. Ken Minnaert's 26-year tenure as president of South Puget Sound Community College culminated in the dedication of the college's *Kenneth J. Minnaert Center for the Arts*. Ken's roots, however, remain in the high school industrial arts classes he taught early in his career.



For sending a honey of a tip, Ken receives four Stanley Sweetheart hand planes. Great job, Doc!

Top tips earn tools!

Tell us how you've solved a workshop stumper. If we print it, you'll get \$100 and a copy of *450+ Best-Ever Shop Tips* (woodmagazine.com/450tips). And, if your idea garners Top Shop Tip honors, we'll also reward you with a tool prize worth at least \$300.

Send your best ideas, along with photos or drawings and your daytime phone number, to: **Shop Tips, WOOD Magazine, 1716 Locust St., LS-221, Des Moines, IA 50309-3023**. Or, by e-mail: shoptips@woodmagazine.com. Include your contact info in the e-mail.

Because we try to publish original tips, please send your tips only to WOOD® magazine. Sorry, submitted materials can't be returned.



THE POWER
AND VERSATILITY
OF SIX TOOLS.
PACKED INTO ONE.

INTRODUCING THE 12-VOLT CRAFTSMAN CORDLESS MULTI-TOOL

With the ability to sand, scrape, saw, and smooth, this portable tool puts the power to complete any job right in the palm of your hand. With innovation and better value, trust that Craftsman has the tool to get the job done right. Find it at craftsman.com

Sears THE HEADQUARTERS OF CRAFTSMAN

CRAFTSMAN

TRUST IN YOUR HANDS.

STRONG BOND

WITH LESS CLAMP TIME.



High strength with a shorter clamp time along with no dyes for a natural finish makes Gorilla Wood Glue ideal for your woodworking and building projects.

FOR THE TOUGHEST JOBS ON PLANET EARTH.®

GORILLA TOUGH .COM

1-800-966-3458 Made in U.S.A.

© 2009 Santa Fe Company

Shop Tips

No-fuss mortise setup

I like to cut mortises and stopped grooves using the router table. Here's my method for skipping the hassle of a time-consuming trial-and-error set-up process.

After laying out the mortise or stopped groove, use a Forstner bit to

drill a hole at each end of the mortise or groove. Then at your router table, drop one of the holes over the router bit to set bit height, the fence position, and your first stopblock. Use the other hole to set the opposite stopblock, and you're set up to make the cut.

—Philip Exance, Bridgewater, Conn.

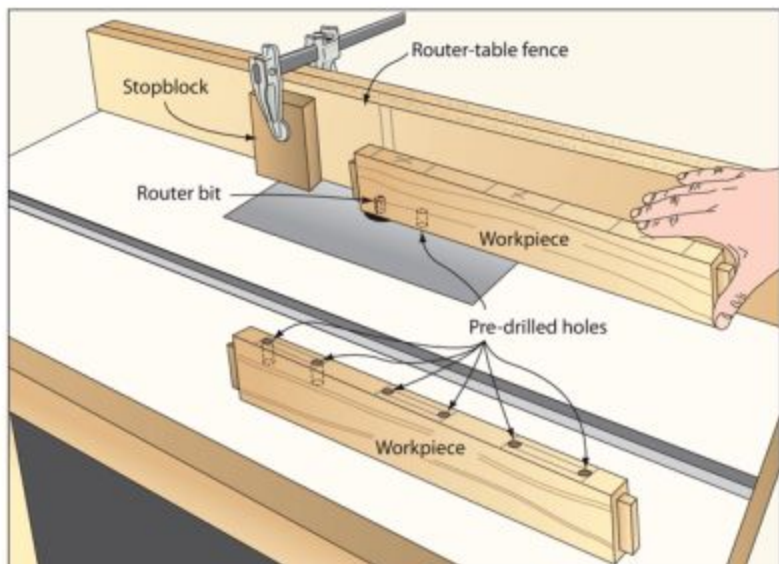

Two-in-one insert for extended life

I use a zero-clearance insert for making nearly all tablesaw cuts, so I go through a lot of inserts. To extend the life of your inserts, simply rotate them. First use one side with your thin-kerf blade.

When it gets chewed up enough to start losing effectiveness, designate that slot as the full-kerf side, and turn the insert around. The fresh side becomes zero-clearance for the thin-kerf blade once again.

—Craig Richardson, Ottumwa, Iowa

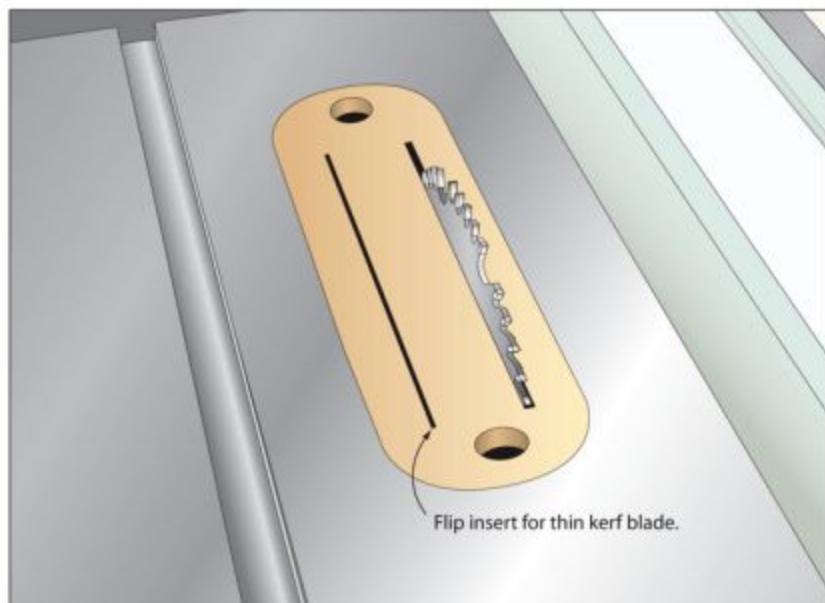

Shop Tips

Go-anywhere mini spraybooth

I like to finish my small turned projects with aerosol spray lacquer, but don't like the fumes in my shop. So I made this portable spray booth from scrap plywood. The simple 12×16×16" box features two lazy-Susan bearings—one inside the top that holds a cup hook for hanging small parts, and one in the bottom for larger vessels. When it comes time to spray finish, I carry the box outside using the drawer-pull handle. The lazy-Susan bearings let me rotate the parts as I spray, for full coverage. Then, I just carry the box back into the shop for drying.

—Del Kramersmeier, Eagle Grove, Iowa

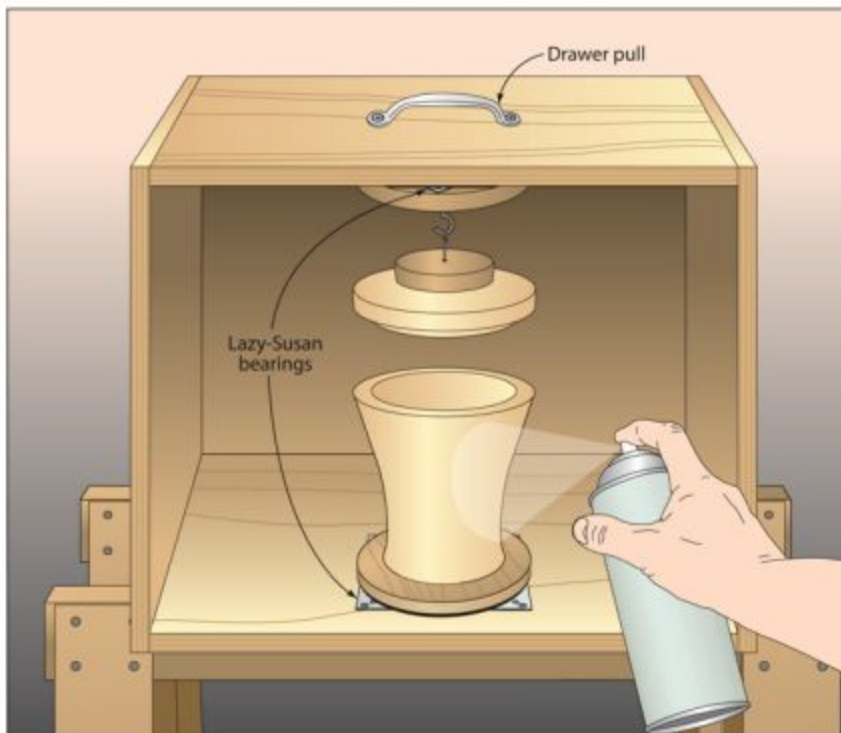

continued on page 12

Discover the hobby that becomes a passion

Call or go online for a FREE catalog
and FREE pen making DVD

GET STARTED

making spectacular pens this winter



HUGE LATHE SALE!

on our compact, powerful Turncrafter Pro
midi lathes



shown: #TCLPROVS

Turncrafter Pro
1/2HP Multi Speed
Midi Lathe
Item: #TCLPRO
Reg. \$189.95
Save \$30 \$159.95

Turncrafter Pro
1/2HP Variable Speed
Midi Lathe
Item: #TCLPROVS
Reg. \$279.95
Save \$50 \$229.95

Plus, save up to \$150 on 6 Turncrafter Pro
Pen Making Starter Sets.

Call or visit www.pennstateind.com/lathesale to learn more.

*Limited time only, so act fast!

Penn State Industries

1-800-377-7297 • www.pennstateind.com



Kreg Jig®

Micro Pocket™ Drill Guide

With a 25% smaller hole diameter, the Micro Pocket™ Drill Guide lets you create a more compact, low-profile, Pocket-Hole in thinner stock than our standard Drill Guide. Perfect for 1/2" material.

KJMCRDGB \$49⁹⁹



NEW

Compatible with K3, 7 & 8 heads

Quick-Change Kit

Switch from drilling Pocket-Holes to driving Pocket-Screws in just seconds! The Complete Quick-Change Kit includes everything you need to get started!

QUK-KIT \$29⁹⁹



NEW

The Innovation Continues...

Beaded Face-Frames are a great way to add detail and richness to your cabinetry work. Problem is... they're difficult to build and take a lot of time and effort! Until now. Thanks to our all new Precision Beaded Face-Frame System, anyone can build beautiful face-frames quickly, easily, and more affordably than ever before!

Visit www.kregtool.com/beaded today to watch the video and learn more!

Kreg

800.447.8638

www.kregtool.com

Shop Tips

Corner clamp converters

These corner clamping blocks help me squarely glue up mitered frames of almost any size. Each block consists of two pieces of 2 1/4" laminated hardwood. In the top piece, I drilled a 3/8" hole in the center to allow for glue squeeze-out. Then, backing the piece with an auxiliary fence on my miter gauge, I cut

the squared notches by running it through the tablesaw on edge. Finally, I glue the top and bottom blocks together, and cut slots in the sides and bottoms sized to corral my bar clamps. (Cut on the sides shown *bottom*.) Scraps of acrylic epoxied to the notches ensure that any glue squeeze-out comes off.

—Max Young, Albion, Ind.

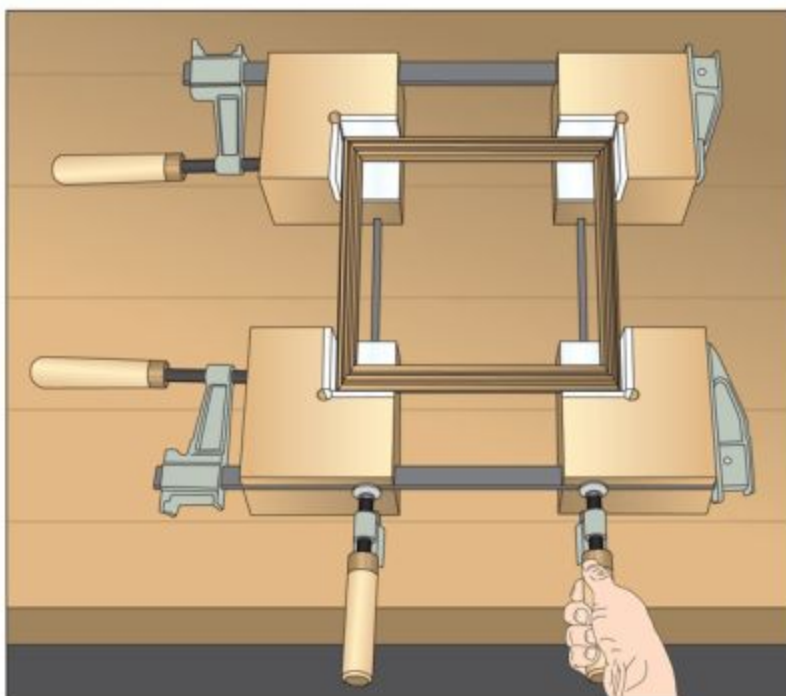
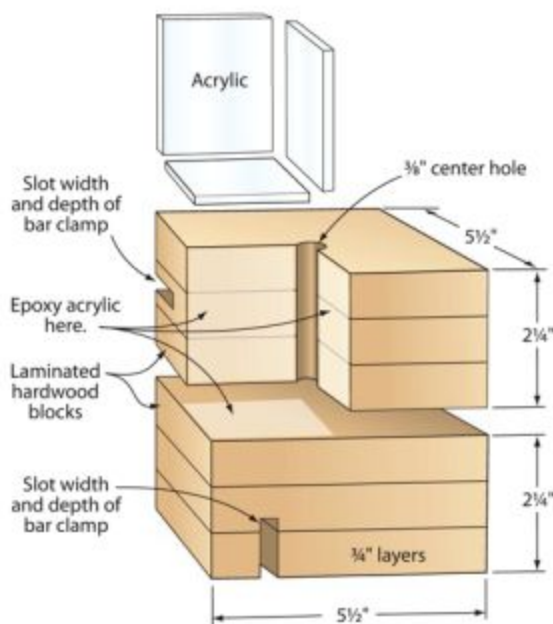

Plan easel is a step up

The plans for a recent project came printed on a 2x3' sheet of paper and were accompanied by about 10 pages of instructions. I wanted to keep everything handy for reference, but there is nowhere near the amount of vertical or horizontal space in my shop to display the plans. The solution: this temporary easel quickly constructed from an aluminum stepladder, a couple 2x3' pieces of plywood, and a few machine screws. I taped up the plans in easy view. The ladder still folds to get it out of the way. Or if I need to use it as a ladder, it's no problem to quickly remove the screws.

—Joel Simmons, McDonough, Ga.

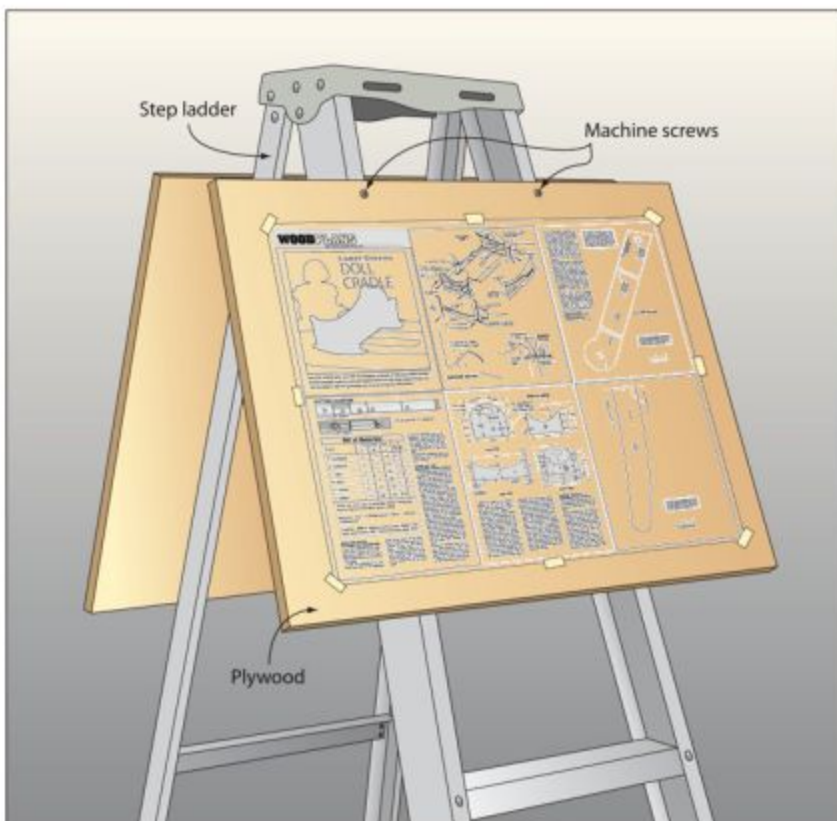

continued on page 14

Breathe Easier with a One Stop Dust Collection Solution

With 20 years experience and a superior product line, the experts at Penn State Industries will provide you effective solutions for a cleaner shop.



**BEST IN CLASS
Cyclone Filtration**
452-700 sq. ft.
at 1/2-micron capturing
99.9% of particles.

TEMPEST™ S-series Cyclones

- ▲ 2.5HP - 1450CFM - \$995
- ▲ 3.5HP - 1700CFM - \$1125
- ▲ 5.0HP - 1800CFM - \$1395

Premium Ductwork

- ▲ Pipe for maximum airflow
- ▲ Fittings and hoods for most applications

Ductwork Planning Service

- ▲ An accurate layout of your shop to save you hours of planning

More Collection Solutions

- ▲ High performance bag-style collectors, air cleaners and portable collectors ideal for any size home shop

**2 GREAT WAYS
TO SAVE**

FREE DUCTWORK PLAN



& \$100 OFF

S-series TEMPEST™ cyclones.
Call for details and mention code: **WOOD5**
Offer expires 2/1/10

Call Bill for your free consultation at 1-800-377-7297 x16 to help you plan the best solution for your shop or CNC application.

Penn State Industries

1-800-377-7297 • www.pennstateind.com/nodustwm

Ready for the next level?

Berea Brand Pen Kits!

- High Quality
- Original Designs
- Reasonably Priced

Visit us at www.bereahardwoods.com or call us at 1-877-736-5487 or e-mail us at bereahard@aol.com



BereaHardWoods CO., Inc.
18745 Sheldon Rd • Middleburg Hts., OH 44130

CMT ORANGE TOOLS

BUY THE QUALITY AND SAVE!

MADE IN ITALY

Here is a chance that doesn't come along every day. A chance to put CMT Quality in your workshop at wholesale prices!

Now available through acetoolonline.com, routerbitworld.com, www.hardware.com, woodwerks.com and participating dealers.

Offer expires December 31, 2009

#800.513.11 3 pc Kitchen Set Reg \$248.00 PROMO \$129.00	#800.517.11 3 pc Kitchen Set w/Backcutter Reg \$285.70 PROMO \$139.90	#800.527.11 Entry & Interior Door Router Bit Set Reg \$399.00 PROMO \$199.00	#800.627.11 Tenon Cutting Router Bit Reg \$158.00 PROMO \$79.90
--	---	--	---

Call or email us at - 888-268-2487 info@cmtusa.com www.cmtusa.com
© C.M.T. UTENSILI S.P.A. TM, CMT, the CMT logo and the orange color applied to tool surfaces are trademarks of C.M.T. UTENSILI S.P.A.

CHOOSE THE TOOL THAT WORKS FOR YOU

AND YOU'LL SAVE TIME AND MONEY.

Material Estimator™

Materials Estimating Calculator

With the Material Estimator you can quickly and easily calculate Yards, Feet, Inches, Fractions and Meters and material costs and allowances to get exactly the materials you need. Prevent estimating errors and save time and money. **Model 4019**

Construction Master® Pro

Advanced Feet-Inch-Fraction Construction-Math Calculator

It features more powerful built-in solutions, in addition to those found in the Measure Master Pro. The perfect tool if your woodworking passion includes projects such as remodeling or adding a room. It even provides Angles for compound miters. **Model 4065**

Home ProjectCalc®

Do-It-Yourself Project Calculator

Simplify your home improvement projects with this easy-to-use calculator. Built-in function keys let you quickly and accurately find material requirements for paint, concrete, tiles, wallpaper and carpet. **Model 8510**

To see how these tools can help you today, go to

www.calculated.com

WD-1209

Shop Tips

Sure-fire center finder for firewood

I've found some of the most beautiful turning blanks in the firewood pile. The good news: It's free. Bad news: It's hard to find the center of odd-shaped pieces. So I've come up with this trick to solve that dilemma.

Mount a piece of scrap wood to your lathe's faceplate. Then attach a piece of acrylic using double-faced tape and chuck it in your lathe. Turn the acrylic to a disc. Use a $\frac{3}{32}$ " bit in a tail-stock chuck to drill a hole through the centerpoint, and then scribe concentric circles on the disc at $\frac{1}{2}$ " intervals with a skew chisel.

To use the centerfinder, position it over the end of the stock, adjusting it until one of the circles is completely inscribed in the solid, usable portion of the wood. Then use a nail set or an awl to mark the center through the hole in the disc.

—Dick Ayers, Barron, Wis.

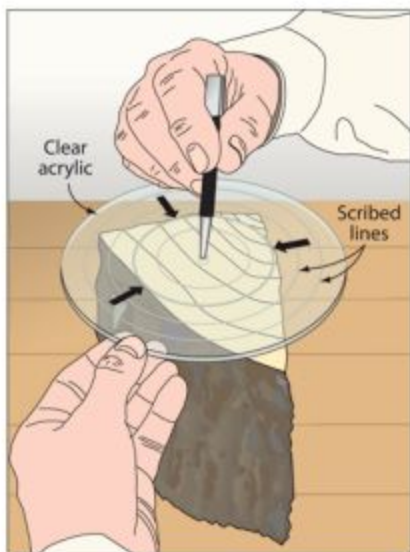

Get 25 years of
WOOD Magazine on DVD:
woodmagazine.com/dvdlibrary



For a dealer near you call 1-800-854-8075

4840 Hytech Drive, Carson City, NV 89706 • 1-775-885-4900 Fax: 1-775-885-4949

Always reveal your butt hinges evenly

Installing butt hinges for inset doors while ensuring a consistent hinge exposure on flush-mounted doors has always given me grief. This simple jig makes it easy, though. I made it out of a 1x2" strip of wood with a 1/4x1/4" stop strip glued to the edge, as shown. The location of the stop determines the reveal, or how much the hinge sticks out from the face frame. (I use 1/4".)

To put it to use, simply clamp the guide to the face frame and butt the hinge against the fence to position it for drilling. Once finished, do the same on the door. When you attach the doors to the frame, they will come out flush every time.

—Charles Paukert, Cedar Creek, Neb.

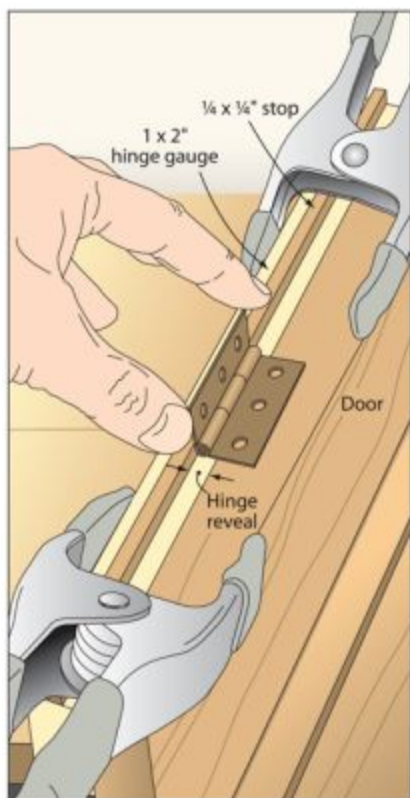

Find more shoptips at:
woodmagazine.com/freeplans



Running tight on clamps? Add pegs

With clamps running short on a cabinet job, I needed a good way to secure face frames. So I improvised, making a pegged block that fit into the shelf-pin holes in the case side. Then, the pressure from a c-clamp forced a tight glue joint between the frame and the case side.

—Daryl Sullivan, Cedar Falls, Iowa

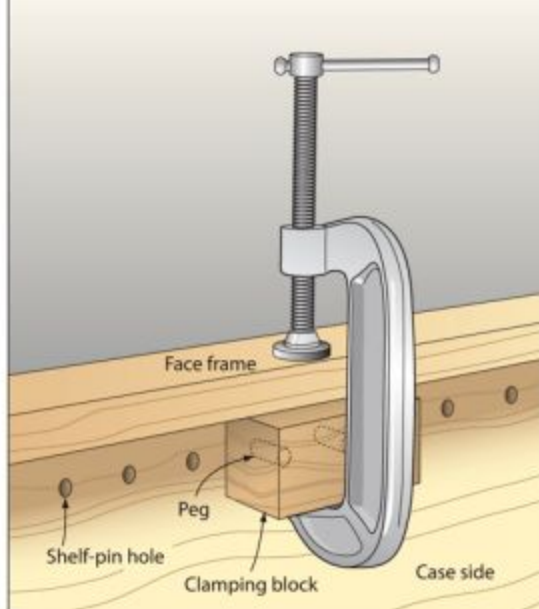

CAUTION: FAST, SIMPLE SHARPENING WILL LEAD TO MORE PROJECTS



Drill Doctor
 The Drill Bit Sharpener

Sharpens your dull and broken drill bits

- E-Z Align System — assures correct sharpening alignment
- Patented dual-cam sharpening system — professionally sharpen your bits
- Diamond sharpening wheel — long lasting

WORK SHARP
 The Wood Tool Sharpener

Sharpens your woodworking tools

- Fast, precise, repeatable results every time
- Air-cooled dry sharpening system — no mess
- Complete sharpening system, no jigs needed

DRILL DOCTOR and WORK SHARP created & assembled in the USA



See our video demos at
www.DrillDoctor.com



See our video demos at
www.WorkSharpTools.com

The Shop Monkey

Don't be afraid... he's trained.



Precisely how precise?

During a visit to a woodworking friend's home, my pal asked me to check out his tablesaw. He was having "issues" with the set-up and wanted a second opinion.

There in his garage shop was a nice contractor's saw, complete with a shiny top, perfectly lubricated handwheel threads, and not a speck of dust on it. While I admired the gleaming saw, my friend passed me a board he had ripped on it. I sighted down the cut edge and noticed the smallest amount of roughness on the cut. Trust me; you really had to squint to see anything.

Next, he removed the saw's throat plate and blade, and went to a special drawer where he stored his precision measuring devices. Armed with his machinists dial indicator, he mounted it to the saw top, and gingerly pushed the instrument to the arbor flange.

"There," he said, his voice heavy with disappointment, "The arbor's off by .002", and I'm having a bear of a time getting it perfect."

I looked at the board, noted the measurement, and studied the board again. "Looks good to me," I said.

He sighed, reassembled the saw, made another test cut and held the result up close to my face. "You see?!?" I looked again, and if I squinted just right, turned my head to the side, and positioned the board in the proper raking light, I could barely make out some roughness.

"I dunno... Still looks good to me."

He turned, shook his head and said, "You just don't get it, do you?" It was then that I remembered what he does for a living: My friend is an engineer.

Wood is pretty amazing stuff. It seems so substantial, yet it constantly moves in response to changes in temperature and humidity. Woodworkers for centuries have understood this and adapted their methods of work to account for it.

I get a kick out of woodworkers who routinely turn to machinist's tools to perfect the thickness of a tenon or the fit of a set of dovetails. If you cut the joint on a rainy day and assemble on a

sunny one, you'll see the magic—and feel the frustration—of our preferred medium of work. Hey, we aren't machining parts for the Space Shuttle.

And, getting back to my buddy's beef: Trying to get a perfect "glue-line rip" right off

a tablesaw is an act of magic you don't need to attempt. Many experienced woodworkers will joint a board, rip it an extra 1/32" wide, then joint the ripped edge to smooth it and bring the board down to size.

Remember, when wood is involved, "close enough" is usually close enough. It's more fun to build projects than to worry about thousandths of an inch. 🌲

The Shop Monkey (aka Tom Iovino of Tampa, Fla.) blogs prolifically at woodmagazine.com/shopmonkey.



WIFE APPROVED

THE NEW SAWSTOP PROFESSIONAL CABINET SAW: AFFORDABLE SAFETY AND PERFORMANCE

Listen up guys, your wife is going to love this saw — maybe even more than you do. First, it stops on contact with skin and prevents serious injuries. Second, it's an awesome saw — powerful, well-built, durable. Finally, it's priced about the same as other cabinet saws, so why not choose the one that also comes with peace of mind?



Get the gift you REALLY
want this year!

Don't wait — visit sawstop.com/wifeapproved
We'll send her all the information she'll need to
make your holiday wish come true.



Quick & Easy Jig

Shelf-Pin Jig

Use a plunge router to bore dead-on holes for shelf pins.

Rather than spend \$30 or more for a commercial shelf-pin jig, make your own from scrap material. This simple jig, made from perforated hardboard, has a fence to reference against your workpiece edge. Add an auxiliary subbase—with an indexing pin—to your plunge router, and then simply bore perfectly spaced holes as needed. Make your jig long enough to bore all the holes in a particular workpiece without moving it. Or make a shorter one that you move down by indexing off holes you just made.

Begin by building the jig, as shown in the drawing below. For the auxiliary subbase, we used $\frac{3}{8}$ "-thick clear acrylic for best visibility, but you also can make it from medium-density fiberboard (MDF).

Scribe a straight line down the center of the subbase's longest axis. Bore a $\frac{1}{4}$ " hole on the line centered with the row of holes closest to the fence and a $\frac{3}{8}$ " hole where the centerline intersects the fourth row of holes. Remove your router's regular subbase and center it on the $\frac{3}{8}$ " hole of the auxiliary base. Mark and bore holes for the mounting screws, including a counterbore or countersink to recess the screwheads. Sand a slight chamfer on one end of a $\frac{1}{4}$ " dowel and then cut it to $\frac{3}{16}$ " long. Using super glue or epoxy, install this dowel into the first hole to serve as a registration pin. Now, mount this subbase to your router.

For those times when you need to reposition the jig, make a registration guide from a scrap of solid wood. Bore three $\frac{1}{4}$ " holes and glue in the dowels as shown. The longer center dowel pins the jig into a previously routed hole.

To use the jig, clamp it to your workpiece. In your router, install an upcut spiral router bit the same diameter as the studs of your shelf pins. Set the depth-of-cut stop so it's slightly more than the length of the shelf-pin studs. This jig is set up to bore holes 4" from the fence; if you want holes closer to the edge of your workpiece, use double-faced tape to adhere a spacer, as shown above. Hold the jig alongside the part you're drilling, insert the subbase indexing pin into a hole, power up the router, and bore a hole. Insert the subbase pin into the next hole in the jig and bore again, stepping and repeating as needed. 🌲

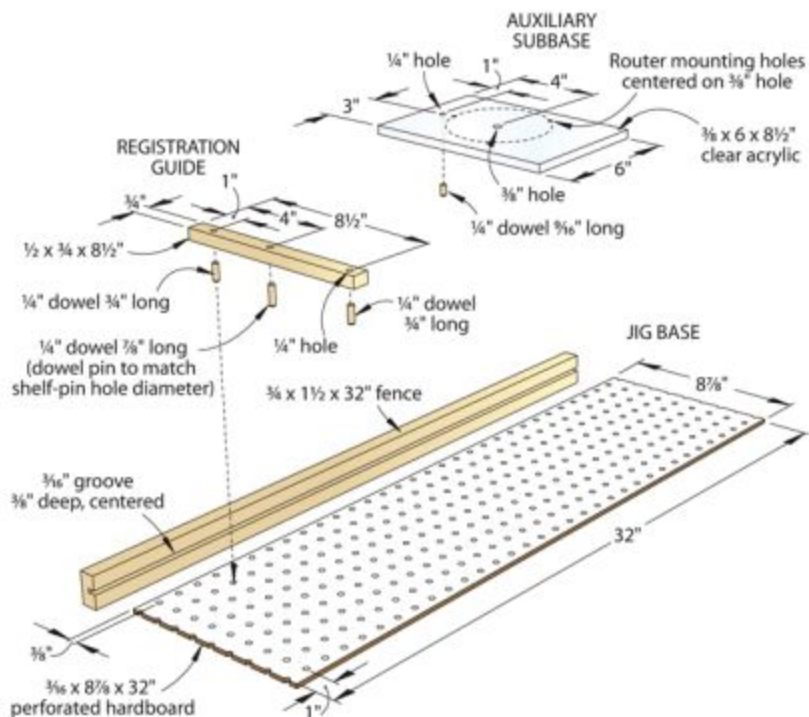

Project design: **Jeff Mertz**
Illustration: **Roxanne LeMoine**

How Do You Turn Your Home's Interior From Ordinary To *Extraordinary?*

With Freud's Architectural Millwork Router Bits!

Turn your home's interior from ordinary to **EXTRAORDINARY** by customizing your trim with Freud's new Architectural Millwork Router Bits! With Freud's new router bits, you will be able to completely customize any room in your house with unique trim in your choice of high quality, stain-grade wood for *a truly exceptional, one-of-a-kind look!*

Now anyone with a 2-1/4 HP router and router table can make *casing, wainscoting, chair rails, baseboards, crown molding, entry & interior doors, French doors and more* from any wood species. Finally, you are able to achieve the design profiles you want for a fraction of the cost of molding from a custom millwork shop.

Don't settle for MDF moldings – Get the natural, beautiful stain-grade wood you've always wanted with the profile that matches your style.



1-800-334-4107
www.freudtools.com/architectural

freud[®]
Precisely the best.

Challenge Skill

Installing a Mortised Lock

With just a few simple tools, you can add security to your projects' lids, drawers, or doors.

Embellishing your project with a mortised lock adds to both its functionality and appearance. Of course, it adds a little more complexity as well. Follow these simple steps to master the mortised lock.

Security starts with a shallow mortise

Nearly all the steps of installing a mortised lock remain the same regardless of its application. We'll use the drawer lock in the Barrister's Bookcase project on page 28 to demonstrate this technique.

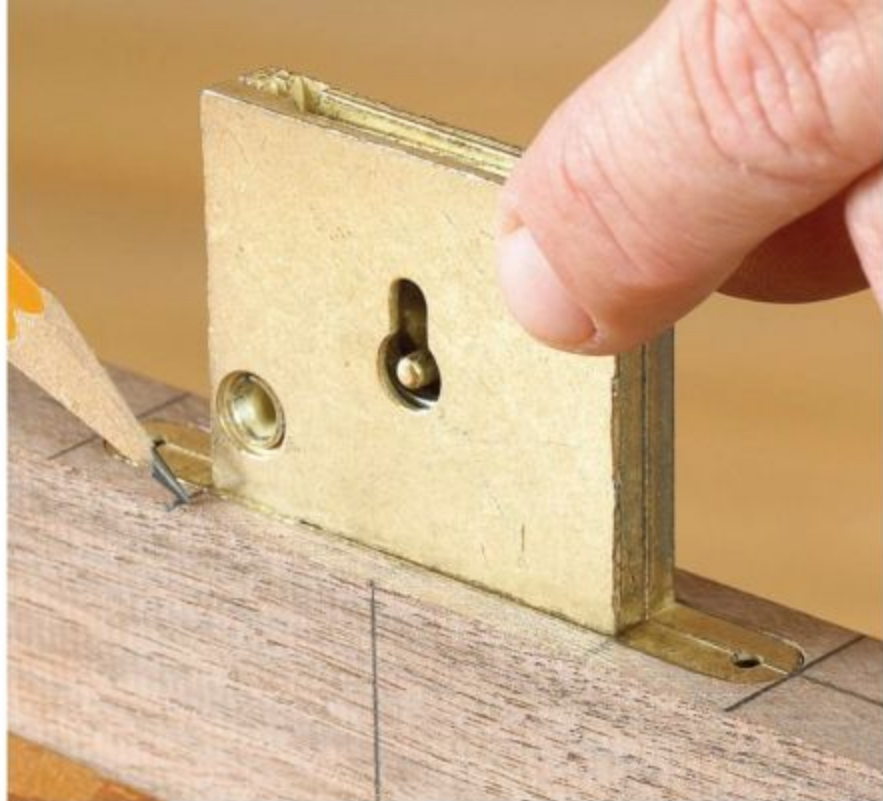

Start by marking a centerline on the top edge and face of the drawer front. Holding the lock against the face, center the lock pin (see drawing) and mark both ends of the lock faceplate on the drawer front's top. (Centering the lock body instead of the pin may place the keyhole off-center if the pin is not centered in the lock.)

In your drill press, install a bit that matches the width of the lock faceplate. (See "Which bit to use?" on page 22.) Set your drill press depth stop so the lock faceplate will sit flush with the top edge of the drawer front, and drill both ends of the marked mortise, with the circumference of the bit just reaching the marked lines [Photo A]. By drilling the ends first, you ensure they will drill out cleanly. If an end is left until last, the overlapping bit may chatter, leaving an imprecise or ragged hole. Don't move your drill press fence—you'll need that setting for the next mortise.

Make a scoring cut on the edges of your mortise with a straightedge and craft knife. Clean up the shallow mortise with the largest chisel that will

continued on page 22

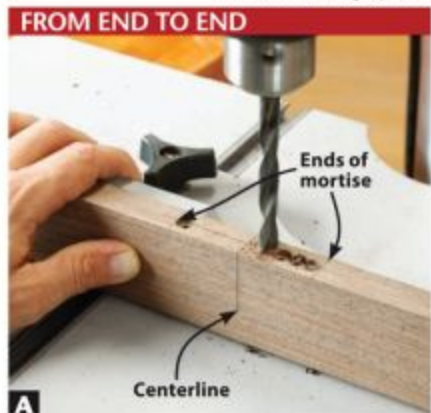
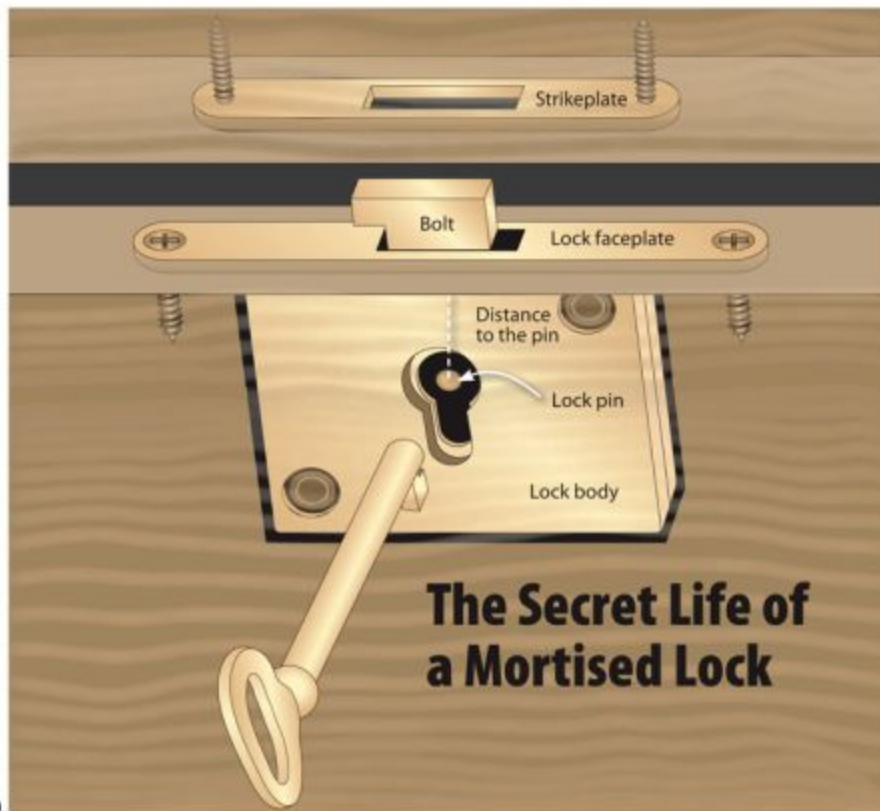

A Drill along the length of the mortise and overlap each hole to remove the most waste.

Free "Online Videos" show you how to join it, rout it, and clamp it, at... **MLCSwoodworking.com**



"Spin Control"

Our Router Speed Control reduces speed without reducing torque! Work at the best speed for your bit and wood. Adjust from 0 RPM to full speed.

#9410 • 20 AMP.....\$34.95

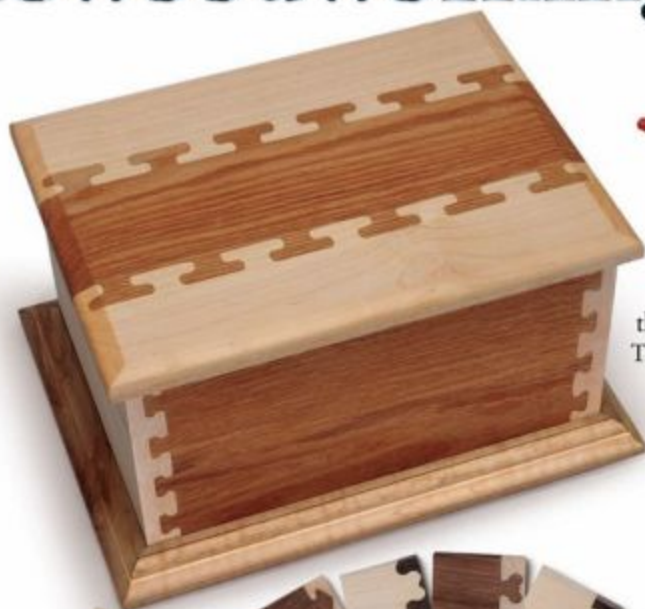

"Hot New Joints"

The Fast Joint System creates unique joints quickly and easily. Includes everything you need to make exquisite joinery: The jig, joint templates, clamps, bushings and router bits. Two Sets available.

#9411 • 4 Template Set.....\$169.95

#9422 • 11 Template Set.....\$269.95



"45 Different Cuts"

Our 45 piece, carbide tipped Router Bit Set includes straight, round over, chamfer, cove... 20 profiles in all! FREE lube!

1/4" shank • #6074.....\$119.95

1/2" shank • #8374.....\$119.95



"Band Together"

The Merle Band Clamp features dual-pivoting jaws that align to any angle! Features 23' steel banding and four corners. The Shopmaster Set includes 4 clamps and 8 extra corners.

#9012 • Merle Clamp\$27.95

#9007 • ShopMaster Set\$114.95



"Routing Heavyweight"

Our 120 lb. Heavyweight Router Table and Fence features a large cast-iron top, universal clamping system, tilt-up access, split fence with dust port, sturdy stand and miter gauge.

#2387 • ON SALE! Save \$70.....\$299.95

1-800-533-9298
PROFESSIONAL ROUTER BITS & WOODWORKING PRODUCTS

MLCS

FREE SHIPPING!
IN CONTIGUOUS USA • P.O. BOX 165 DL, HV, PA, 19006 *2010

Challenge Skill

IT'S OKAY TO BE SHALLOW

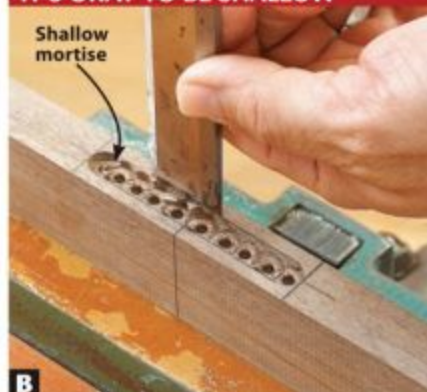

Taking care to keep the chisel perpendicular to the drawer edge ensures a tight fit.

GIVE IT A TWIST



Twist the key to transfer the marker ink on the bolt to where the strike plate should go.

fit [Photo B]. Invert the lock to check the faceplate depth—if the mortise isn't deep enough, use a narrow chisel.

With the lock inverted in the shallow mortise, transfer both ends of the lock body to the rail edge [see opener]. After setting your drill press and bit to the same depth as the lock body, prepare to drill the deep mortise. Unlike the shallow mortise, begin drilling both ends of the deep mortise by *centering* your drill bit over the end lines rather

Which bit to use?

While drilling a mortise, a Forstner bit drills cleanly, without chatter, and the overlapping holes leave less waste to remove later with a chisel. For our project, however, we needed to use a hand drill to mortise the strike plate inside the drawer opening—and a Forstner bit won't accept a stop collar. So our second-best option was a brad point bit, which still allows for some overlap and can be marked for consistent depth with an ordinary stop collar. If you don't have a brad-point bit to match the plate's width, you can make it work by separating each hole by $\frac{1}{4}$ ", and chiseling away the remainder.



KNOW YOUR VERTICAL LIMITS



Be sure to drill your keyholes just slightly larger than the tip of the key to allow for fit.

SCORE ONE FOR THE CRAFT KNIFE

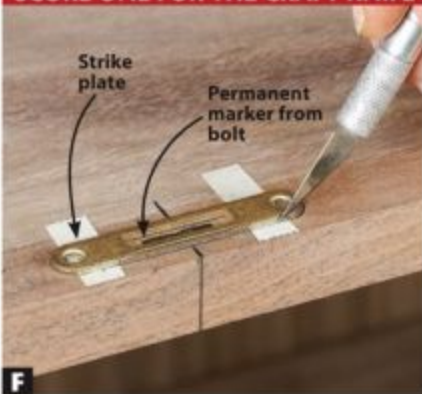

Scoring the outline of the strikeplate will help to keep your chisel on track.

than abutting the circumference of the bit to the edge. This allows the mortise to accommodate the squared edges of the lock body. Chisel and clean up the deep mortise to fit the lock body.

Eyeball the keyhole

Using the centerline on the face of the drawer front, center the tip of the key and mark its vertical limits [Photo C]. Insert a filler shim in place of your lock while drilling the keyhole [Photo D].

FILLER AND DRILL'ER



Inserting a shim into the mortise while drilling the keyhole prevents blowout.

STRIKE PLATE PLACE



Clean the edge of the shallow mortise with a chisel; then check the fit of the strikeplate.

Insert the lock, drill the appropriate pilot holes, and secure with screws.

Coordinate the plate

To quickly and accurately mark the location of your strike plate mortise, generously coat the end of the bolt with a permanent marker, close the drawer, and turn the key to engage the bolt against the corresponding rail [Photo E]. With double-faced tape, center the strike plate over the mark and score the outline with a craft knife [Photo F].

Using the same procedure as with the lock faceplate, drill a shallow mortise [Photo G]. Mark and drill the deep mortise to allow for the bolt to fully engage when turned. If the bolt operates with a hooking motion rather than strictly vertical, you'll have to lengthen the deep mortise to accommodate the bolt's movement. Secure the strike plate with screws. 🌲

Written by **Nate Granzow** with **Jeff Mertz**
Illustration: **Tim Cahill**

Leave it to Bosch to Reinvent

Pneumatic Fastening.



**FULL FORCE
TECHNOLOGY**

Best Power to Size Ratio in the Industry.* Bosch continues its legacy of innovation with its first-ever full line of pneumatic nailers and compressors. Packing 10% more power into the industry's most compact tools, Bosch takes full advantage of superior design to give you precise control and maneuverability. More compact, more powerful and more durable. Full Force Technology – groundbreaking innovation that consistently delivers 100% power.

Get a **FREE TOOL BELT** when you purchase any new Bosch fastening gun or compressor**



BOSCH

Invented for life

* Excludes high pressure systems. Test conducted at Robert Bosch Tool Corp.
** While supplies last. See boschtools.com/guns-n-hoses for details.

boschtools.com/guns-n-hoses

Wise Buys

Our Editors Test

Benchtop Spindle Sanders

Why buy?

Nothing beats a spindle sander for smoothing curved edges. Because the spindle oscillates up and down as it spins, it sands efficiently with greater stock removal, less burning, and longer abrasive life than you get with a non-oscillating drum. These benchtop models will handle nearly any curve-sanding task, for a fraction of the cost of a heavier floor model. We tested seven models and recommend the four below. All have sufficient power, come with at least four sanding drums, and include onboard storage for all parts.

GRIZZLY #G0538, \$150



6 sanding drums: 1/2", 3/4", 1", 1 1/2", 2", and 3" in diameter
Includes: 6 insert rings, wrenches
Weight: 34 lbs

Editor test-drive:

The Grizzly G0538 features a 14x20" laminate-covered MDF top with the spindle offset. I like that, because most of the time I'm working on the right side of the spindle. Despite its small size, it sands with gusto while still being easy to finesse. My shop-vacuum hose

connected easily to the 2 1/2" port below the table and sucked up all the dust. I had to anchor it to my workbench, though, because the lightweight unit scooted around when unsecured.

—Tested by Jeff Mertz, Design Editor



To learn more:

800-523-4777; grizzly.com

RIDGID #EB4424, \$200



5 sanding drums: 1/2", 3/4", 1", 1 1/2", and 2" in diameter
Includes: 4 insert rings, drum washers, belt-sanding attachment, workpiece stop, hex wrenches
Weight: 40 lbs

Editor test-drive:

Not only is this machine nearly unstoppable as an oscillating spindle sander, it's also a 4x24" oscillating edge sander. The belt drive fits into the same drive shaft as the drums, and provides about 8" of working belt length. It takes about 30 seconds to

make the change to spindle sanding. The front of the aluminum table tilts down to 48°. My shop vacuum hooked up easily to the 2 1/2" dust port and gathered in all but a little dust behind the drums.

—Tested by Dave Campbell, Deputy Editor



To learn more:

866-539-1710; ridgid.com

CRAFTSMAN 21500, \$280



6 sanding drums: 1/2", 3/4", 1", 1 1/2", 2", and 3" in diameter
Includes: 6 insert rings, drum washers
Weight: 58 lbs

Editor test-drive:

There's nothing fancy about this unit, but it does everything I need a spindle sander to do. The 18" diameter cast-iron table provides plenty of work surface, and beefs up the vibration-eliminating weight to 58 lbs. The Craftsman 21500 has a 3"-diameter spindle,

something Ridgid and General International don't offer. I force-fed hard maple and cherry against the spindles and could not bog it down. The 2 1/2" dust port fit my shop vacuum hose precisely for good dust collection.

—Tested by Lucas Peters, Multimedia Editor



To learn more:

800-383-4814; craftsman.com

GENERAL INTERNATIONAL 15-220-M1, \$430



5 sanding drums: 1/2", 3/4", 1", 1 1/2", and 2" in diameter
Includes: 4 insert rings, wrenches
Weight: 81 lbs

Editor test-drive:

Why pay this much for a benchtop spindle sander? Because the 81-lb heft of a rugged cast-iron top and heavy steel base eliminates vibration, and the 1/2-hp motor—twice as big as the competitors—powers through wood without a hint of stalling. I like the test-tallest

5 1/2" sanding drums (other makes are 4 1/2") for those rare occasions when I need to sand a workpiece that large. The table tilts to 45° for angled work. And there's an adapter included to hook up a 4" dust hose to the 2" port.

—Tested by Craig Ruegsegger, Multimedia Editor



To learn more:

888-949-1161; general.ca



Lift, grip and protect your projects



26357
Four cookies,
just \$11.99

Our new Bench Cookies are revolutionizing the workshop, allowing for stable routing, sanding, carving and other tasks without traditional clamps. The secret? Non-marring rubber pads that solidly grip both the bench and your workpiece. They also elevate your projects for complete access to every edge, making finishing and edge work easy. Sturdy and simple to set up, Bench Cookies are guaranteed to help you **Create with Confidence.**



Start to FINISH...

The Finishing Store.com

- TRADE SECRETS
- EXPERT VIDEOS
- PRECISION PRODUCTS
- SUPER SAVINGS

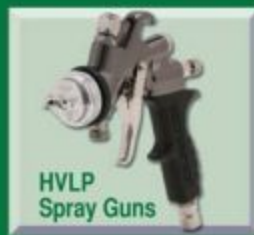

BROWSE OVER 400 EXPERT PRODUCTS, TIPS AND TRICKS, PLUS SUPER SAVINGS.

Call or Click today 1-888-900-4857 or www.TheFinishingStore.com

Dept. w1209

SOMMERFELD'S TOOLS

For Wood

Creative Solutions To Every Woodworking Challenge

The One and Only place for high quality, innovative woodworking tools!

Plus, we offer **FREE Shipping!**



02003 Tongue & Groove Cabinetmaking Set
Sale \$99.⁹⁰



SHB Easy Bore Hinge Boring Jig
Sale \$159.⁹⁰

Cabinetmaker Blade

31003 Cabinetmaker Blade

SALE: \$49.⁹⁰



	EXCELLENT	GOOD	FAIR
Plywood			
Crosscut Wood			
Rip Wood			
Melamine			



For a **FREE 80 page catalog** call today...

Source Code WM0110



Learn the innovative Sommerfeld methods from these eight DVD's. Over 7 Hours of HOW-TO Instruction

8 DVD's Sale \$49.⁹⁰

Toll Free 888-228-9268 • Visit us on the web... www.SOMMERFELDTOOLS.com

The Wood Working Shows DIY

The Hands-on Show for Woodworkers and DIY'ers

GOOD TO KNOW *all new education programs*



- Ship Shape Shop with Jim Heavey
- Finishing Clinic
- Hand Tool Rodeo
- Cabinet Restoration
- Complete Schedule Online

GOOD TO BUY *show exclusive discounts*



- Where woodworkers and DIY'ers in the know stock up
- The best buys of the year
- Find coupons on our website

GOOD TO TRY *test-drive before you buy*



- Put the latest tools to the test before you buy

BE A SHOW-OFF!

Enter your best work in our Show-Off Contest for a chance to win a Delta Unisaw!

Register Online



To register and learn more go to www.thewoodworkingshows.com

Barrister's Bookcase



AT A GLANCE

- Glass doors pivot up and into the case quickly.
- Drawer holds hanging file folders.
- A dado blade, rail-and-stile router bits, and raised-panel bit with back cutter take care of the joinery.



Our twist on this classic project includes a drawer at the bottom to keep files close at hand. Even fully loaded, it rolls in and out easily on heavy-duty drawer slides. The drawer-box joinery requires just a single setup on the tablesaw explained in this article and demonstrated in a free online video at woodmagazine.com/simplifiedrawer.

Every case has two sides

1 Begin by gluing up stock for the panels (A) [Materials List, page 36]. While the panels dry, rip $\frac{3}{4}$ " stock for the top/bottom rails (B), center rails (C), front stiles (D), rear stiles (E), and facing (F) [Drawing 1]. Set up a stopblock and auxiliary fence on your miter gauge and cut the top/bottom rails and center rails to

length. Reset the stopblock and cut the front stiles, rear stiles, and facing to length. Set the facing aside for now.

2 In your table-mounted router, set up the rail router bit with the bearing

flush to the fence face [Photos A, B]. Cut the cope profile on the ends of the top/bottom rails (B) and center rails (C), backing up each workpiece with a pushblock [Photo C].

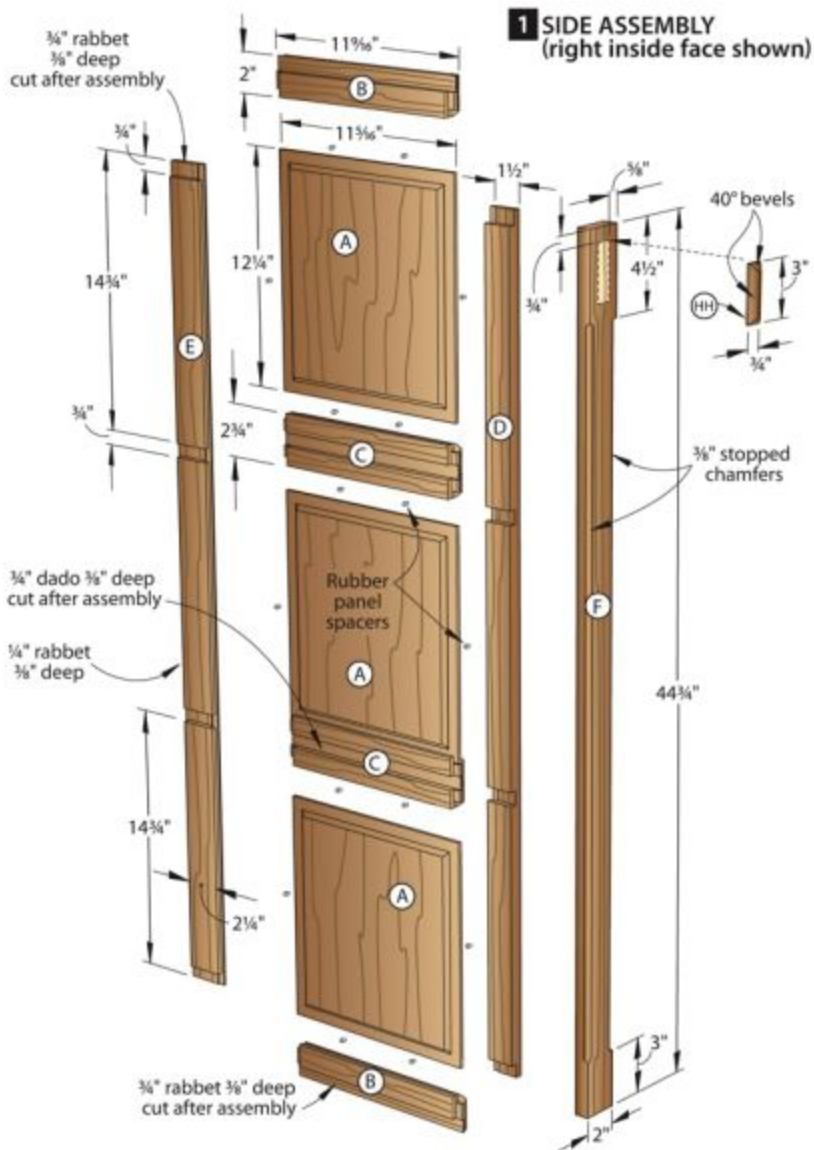

1 SIDE ASSEMBLY (right inside face shown)

COPING WITH COPING THE RAIL ENDS

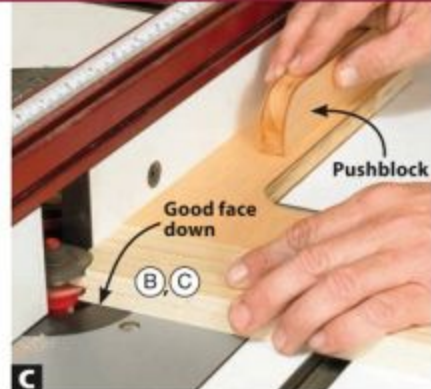
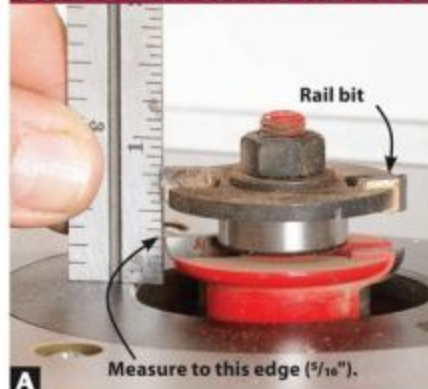

Set the upper edge of the rail bit's lower cutter $\frac{5}{16}$ " above the tabletop (Photo A). Then adjust the fence so it aligns with the bearing of the bit (Photo B). Using a pushblock to steady the rails and prevent tear-out on the back edge (Photo C), rout the rails with the good face down on the tabletop.

SHOP TIP

Sticking the setup

Get perfectly flush faces on the rails (B, C) and stiles (D, E) without measuring. Simply set the height of the stile bit by using a coped rail as a guide. Adjust the bit so the slot cutter aligns with the tongue on the end of the rail.



2 EXPLODED VIEW

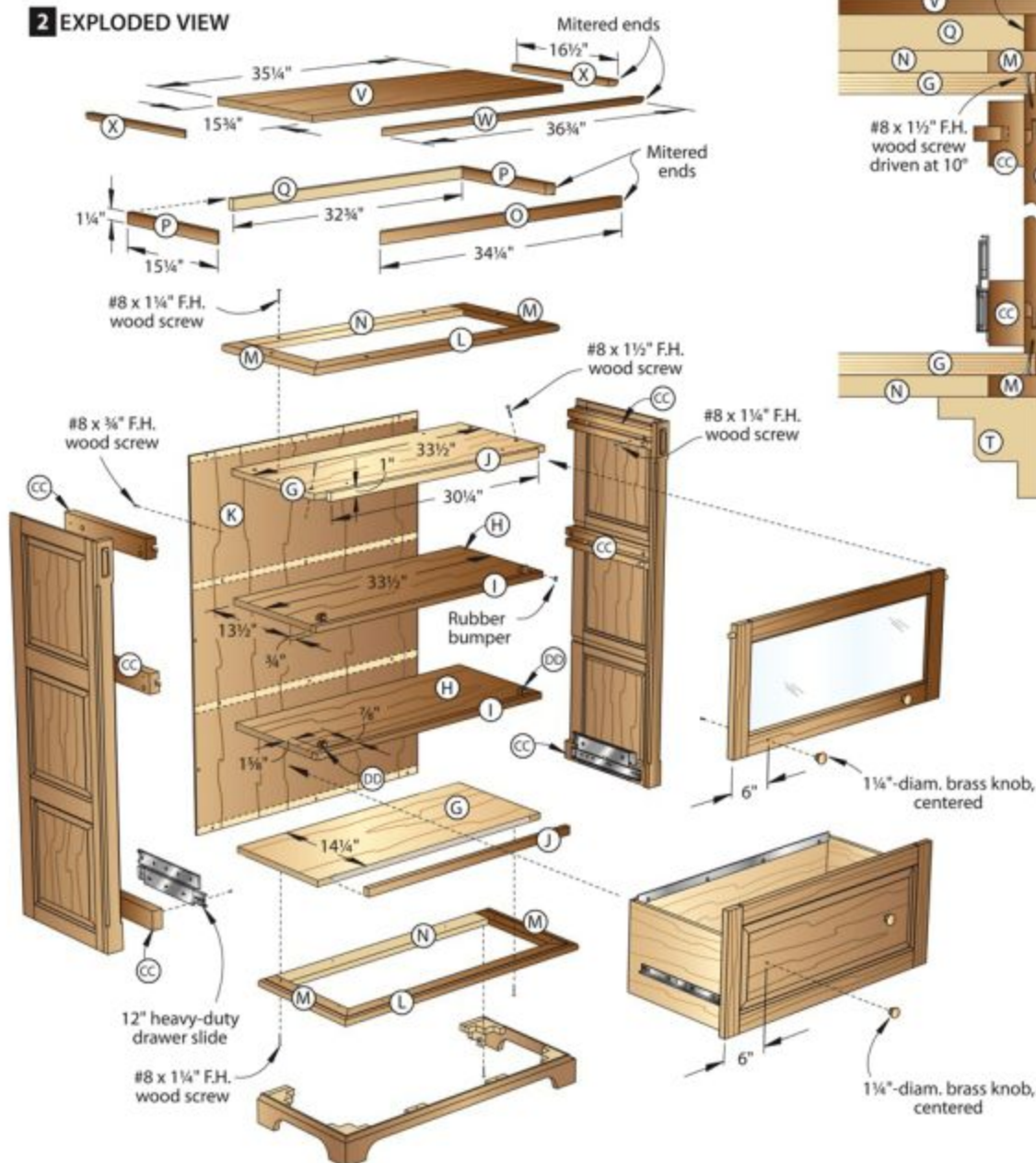

2a FRONT SECTION VIEW

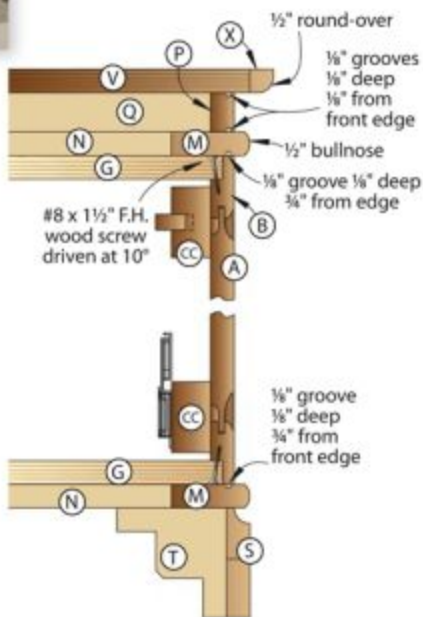

3 Install the stile bit in the router, adjust the bit height [**Shop Tip**, above], and set the fence flush with the bearing. With the good face down, rout the inside edges of the top/bottom rails (B), front stiles (D), and rear stiles (E), and both edges of the center rails (C).

4 Dry-fit the rails (B, C) and stiles (D, E). Position the center rails (C) to create three openings of equal length. **Quick Tip! Marks that stick with it.** To help realign pieces quickly during glue-up, place painter's tape across the joint of each center rail and stile. Mea-

sure the width and height of an opening and add $\frac{1}{16}$ " to each dimension. Retrieve the panels (A) and cut them to these dimensions.

5 Set up a raised-panel bit with back cutter in your table-mounted router and cut the profile around each panel

3 TOP/BOTTOM TRIM FRAME (bottom frame shown)

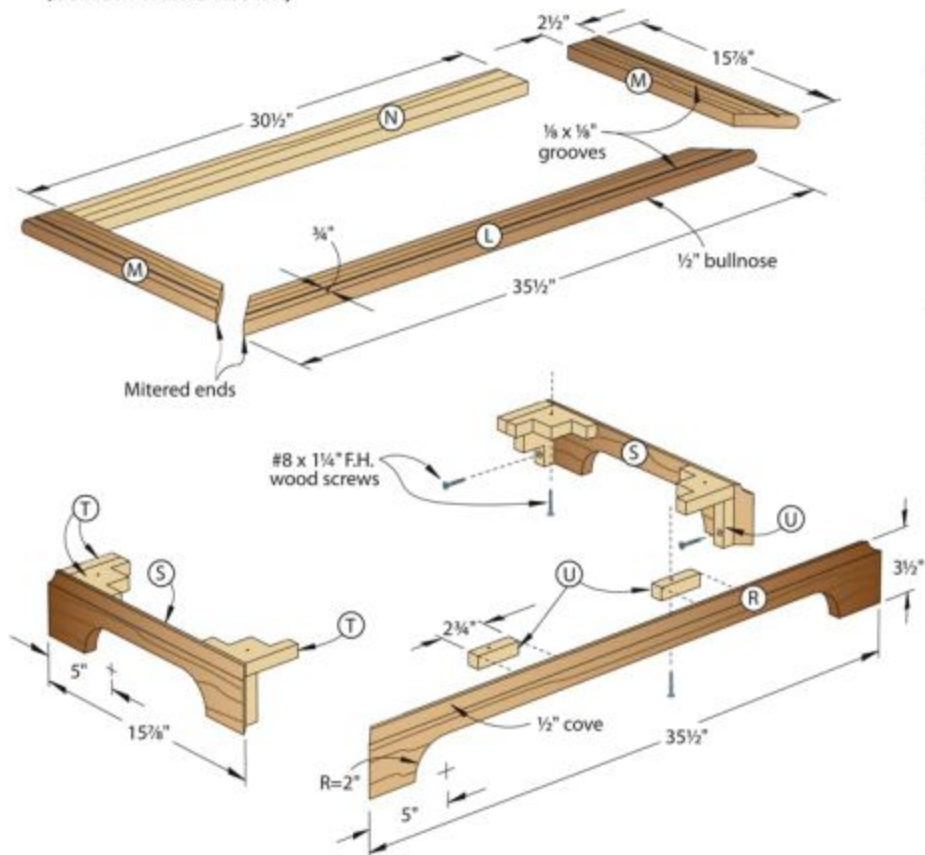

3a FRAME PROFILE DETAIL

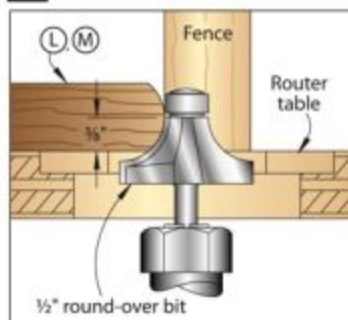

3b CORNER CLEAT

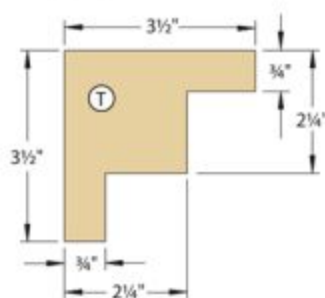

(A). Dry-fit the panels, rails (B, C), and stiles (D, E) and check the fit.

6 Disassemble the parts, sand the panels to 220 grit, and apply a finish to them. (We wiped on one coat of boiled linseed oil topped with a satin-finish polyurethane. A second coat of poly will be added after the cabinet is completed.) Sand the stile profiles, then assemble the sides (A–E) [Photo D], inserting rubber panel spacers in the grooves in the frames [Drawing 1].

Tie the sides together

1 Mount in your tablesaw a dado blade matching the thickness of the shelves (H), and attach an auxiliary fence to the rip fence. With part of the blade housed in the auxiliary fence, cut a rabbet along the back edge of each rear stile (E) [Photo E, Drawing 1].

2 Readjust the fence so the exposed blade width equals the thickness of the top/bottom panels (G). Rabbet the inside top and bottom of each side assembly (A–E). Remove the auxiliary fence, reset the rip fence 14 3/4" from the blade, and cut two dados across each side assembly [Photo F, Drawing 1].

SHOP TIP

Routing perfect stopped chamfers

This simple setup guarantees matching chamfers on each edge of the facing (F). Start by using double-faced tape to attach a T-shaped block to the router-table fence. The width of the vertical stop equals the diameter of the bit bearing plus two times the size of the chamfer. With a 1/2" bearing and a 3/8" chamfer, make the stop 1 1/4" wide. Center the stop over the bit. Next, tape a 3"-long stopblock to one end of the facing and a 4 1/2"-long stopblock to the other, flush with the ends. To rout the chamfers, move the facing into the bit so the left stopblock touches the left side of the T (photo) and push it along the fence



until the right stopblock contacts the T. Flip the facing around and rout the opposite edge. Attach the stopblocks to the other facing and repeat the procedure for four perfectly matched chamfers.



D Line up the pieces of painter's tape to position the rails (C) quickly during glue-up. Cauls protect the edges of the stiles (D, E).

RABBET THE BACK STILE



Cut a $\frac{1}{4}$ " rabbet $\frac{3}{8}$ " deep along the rear edge of the rear stile (E) on each side assembly. The rabbet accepts the back (K).

ONE SETUP FOR TWO DADOES



With each end of each side assembly (A–E) against the rip fence, cut a dado using a long miter-gauge fence to steady the work.

ASSEMBLE THE SIDES AND SHELVES

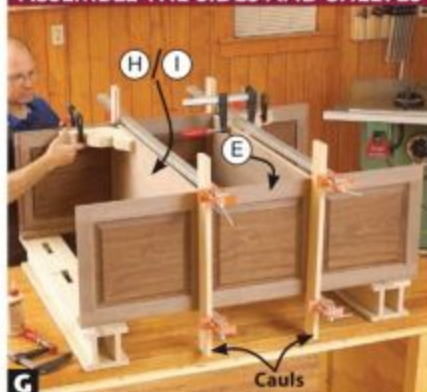

Using cauls and squaring braces, glue and clamp the shelves (H/I) between the side assemblies (A–F).

3 Retrieve the facing (F) and rout stopped chamfers on each front edge [Drawing 1; Shop Tip on page 31].

4 Glue the facing (F) to the front of each side assembly (A–E) with the ends and outside edges flush. **Note:** Make sure the $4\frac{1}{2}$ " unchamfered end is at the top and that the assemblies are mirror images [Drawing 1]. Finish-sand to 220 grit.

5 Cut the top and bottom (G) and shelves (H) to size. Cut the shelf edging (I) to size and glue and clamp it in place [Drawing 2]. Finish-sand the shelves (H/I) through 220 grit, then assemble the sides (A–F) with the shelves [Photo G]. Add the top and bottom [Shop Tip, below right; Drawing 2a].

6 Cut the top/bottom trim (J) to fit between the facings (F). Glue the trim in place, flush with the top face of the top panel and the bottom face of the bottom panel [Drawing 2].

7 From $\frac{1}{4}$ " plywood, cut the back (K) to fit between the rabbets in the side assemblies (A–F), and flush with the top face of the top (G) and bottom face of the bottom (G) [Drawing 2]. Drill holes and screw the back in place to check the fit, then remove it to allow easier access during the rest of construction.

A top and bottom add appeal

1 From $\frac{3}{4}$ " stock, cut the top/bottom trim fronts (L), sides (M), and backs (N), and the extension frame front (O), sides (P), and back (Q) to width, and $\frac{1}{2}$ " longer than listed. Rout a bullnose on one edge of the top/bottom trim front and sides [Drawing 3a]. Then cut $\frac{1}{8}$ " glue-relief grooves on one face of these pieces [Drawings 2a and 3] and on both edges of the extension frame front and sides.

2 Miter-cut both ends of the top trim front (L) so it is $1\frac{1}{4}$ " longer than the

case width. Miter one end of each top trim side (M). Clamp the trim front to the top of the carcass centered side-to-side and with a $\frac{3}{8}$ " overhang in front. Place the trim sides against it. Mark the trim sides' final length [Photo H], cross-cut them to length, and glue and screw the trim front and sides to the carcass. Cut the top trim back (N) to length to fit between the trim sides [Drawing 3] and glue and screw it in place. Repeat this process for the bottom trim frame. Sand the frames to 220 grit.

3 Measure the distance the top frame (L–N) overhangs the top rails (B) and facing (F) [Drawing 2a]. Transfer this dimension to the top faces of the top trim front and sides, parallel with their outside edges. As with the top and bottom frames, miter the extension frame front (O) and sides (P) to fit along the lines [Drawing 2a]. Sand the front and sides to 220 grit, then glue them in place. Cut the extension frame back (Q) to length to fit between the sides, finish-sand it, and glue it in place.

4 Miter-cut the base front (R) to length, then miter-cut and crosscut the base sides (S) to length [Drawing 3]. Rout the $\frac{1}{2}$ " cove along the upper edge of these

pieces, then lay out the profile. Bandsaw the profile and sand it smooth.

5 Bandsaw six corner cleats (T) to size and shape [Drawing 3b]. Glue up the base front (R) and sides (S) using a cleat in each corner [Photo I]. Glue the remaining cleats to the back end of the sides [Drawing 3], then glue and screw a support cleat (U) behind each miter joint [Drawing 3]. Drill countersunk shank holes in two more support cleats and glue them in place, evenly spaced on the back face of the base front.

6 Turn the case upside down and attach the base to the case, flush at the back and centered side-to-side. Drill countersunk shank holes through the corner cleats (T) and drive screws through them and the front support cleats (U) [Drawing 3].

7 Cut the cap panel (V) to size, and the cap front trim (W) and side trim (X) to width and $\frac{1}{2}$ " longer than listed. Then miter the trim pieces to fit around the cap panel [Drawing 2]. Rout a $\frac{1}{2}$ " round-over on the bottom edge of the trim [Drawing 2a]. Then finish-sand the cap assembly and glue it to the extension frame (O–Q) flush at the back and centered side-to-side.

SHOP TIP

Know the angles

Driving a screw straight down into the $\frac{3}{8}$ "-deep rabbet in the top and bottom rails (B) risks blowing out the inside face of the rail. Instead, angle the screw slightly to the outside of the rail to prevent this [Drawing 2a]. Use a scrap block mitered at 10° to help guide your bit at the proper angle while drilling the pilot holes [right].

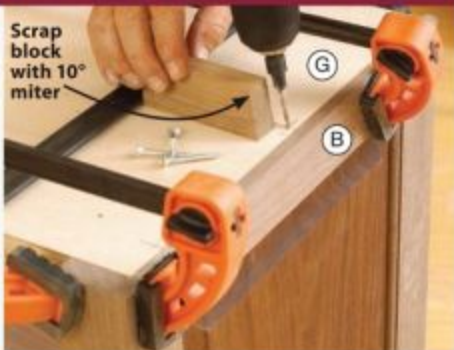



H With the trim front (L) clamped to the case, place the mitered end of a side (M) against it and mark the final length of the side.

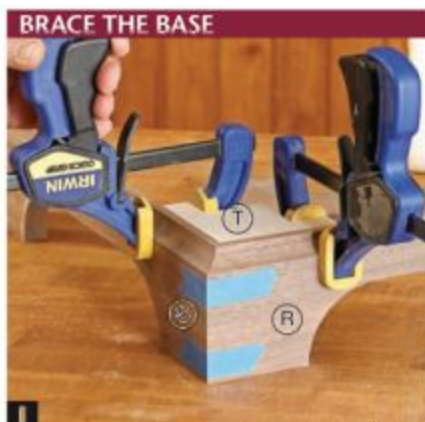

I Glue corner cleats (T) to the base front (R) and sides (S) to reinforce the miter joint and to hold the assembly square.



J Secure the middle door supports (CC) against the bottom of the shelf (H). Use $\frac{1}{4}$ " spacers to position the upper door supports.

4 DOOR (rear view)

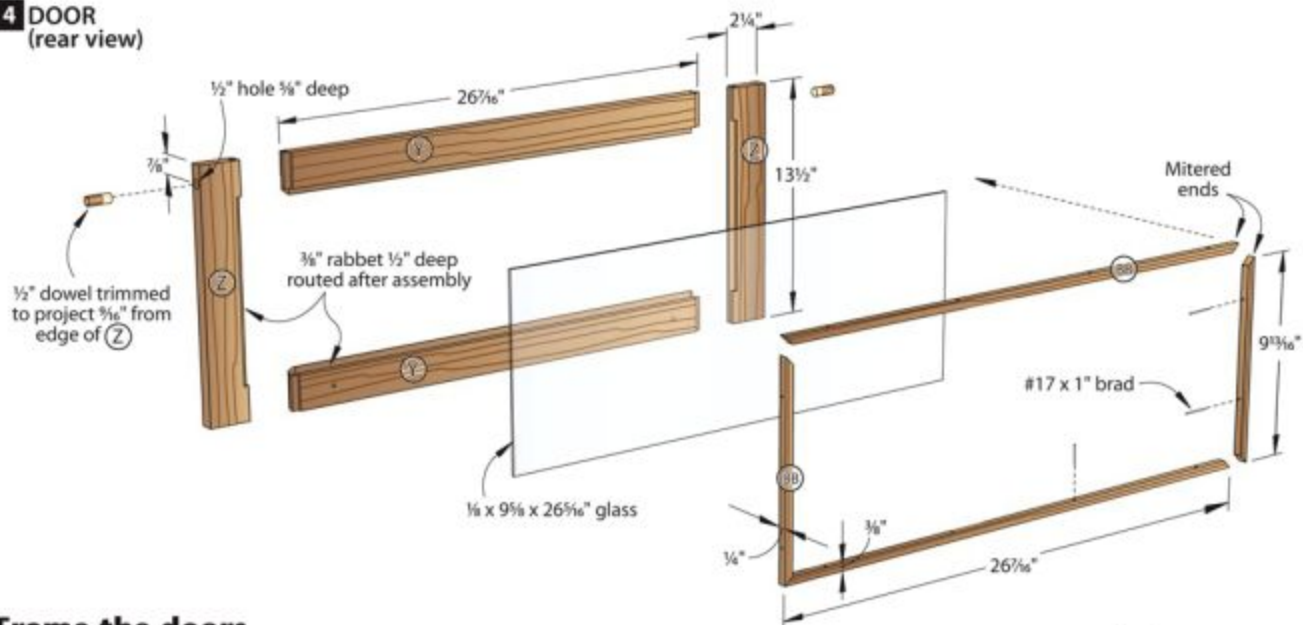

Frame the doors and a false front

1 Measure the openings for the doors and drawer. Crosscut the rails (Y) $3\frac{1}{8}$ " shorter than each opening's width, and the stiles (Z) $\frac{1}{4}$ " shorter than each opening's height. **Note:** Each pair of stiles may not be the same length. If this is the case, mark them to indicate which opening they fit. Drill $\frac{1}{2}$ " holes $\frac{3}{8}$ " deep in the door stiles [Drawing 4]. Glue up stock for the drawer panel (AA) and set it aside for the moment.

2 As you did with the side assemblies (A–F), use your rail-and-stile router bits to cut the joinery on the rails (Y) and stiles (Z). Cut the drawer panel (AA) to size, then rout the profile around it [Drawing 5]. Finish-sand the panel to 220 grit, then apply a finish.

3 Glue up the doors, checking that the frames are square and flat. Then glue dowels in the stiles (Z) and cut them to

length [Drawing 4]. Glue up the drawer frame with the panel (AA), placing rubber spacers in the grooves [Drawing 5].

4 After the glue dries, mount a $\frac{3}{8}$ " rabbeting bit in a handheld router and rabbet the back face of the door frames to accept the glass and stops. Chisel the corners square, then finish-sand the doors and drawer false front (Y/Z/AA). Cut four 38" lengths of glass stop (BB), sand it through 220 grit and set it aside.

5 Glue up stock for the door/drawer supports (CC) and cut them to size. Set two of them aside for use with the drawer later. In the four remaining door supports, cut a $\frac{1}{16}$ " groove and drill two $\frac{1}{2}$ " holes and two $\frac{3}{8}$ " countersunk shank holes [Drawing 6], making sure you end up with two mirrored pairs. Sand the supports to 220 grit, then cut two lengths of $\frac{1}{2}$ " dowel for each door support [Draw-

4a DOOR STOP

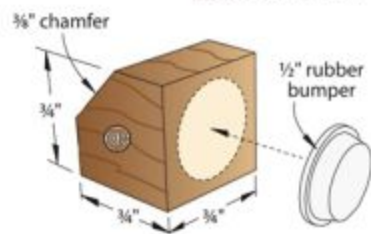

ing 6. Glue the 2"-long dowels in place below the grooves. Set aside the $\frac{1}{4}$ "-long dowels until the doors are installed.

6 Screw the door supports (CC) in the case [Photo J]. Slide the door in from the back of the case [Photo K], then insert (don't glue) a $\frac{1}{4}$ "-long dowel in each door support. Mount the knobs [Drawing 2]. **Quick Tip! Make (and see) your mark.** Put painter's tape on the bottom stiles to make the knob location marks more visible.



K Slide the doors in from the back of the case, bottom edge first, so the door passes above the dowel in the door support (CC).

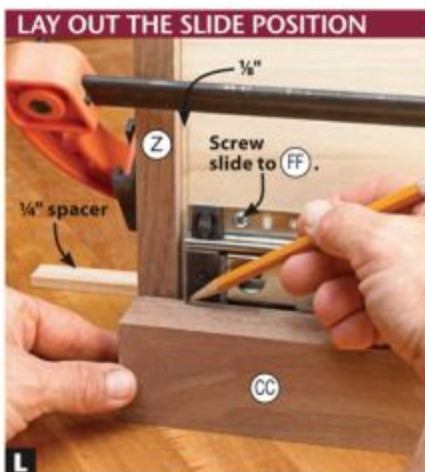

L Placing the drawer and front on a spacer and the slide on the bench creates clearance when the drawer is mounted in the carcass.



M Using a scrap and the mark on the drawer support (CC) for alignment, screw the drawer slide to the drawer support.

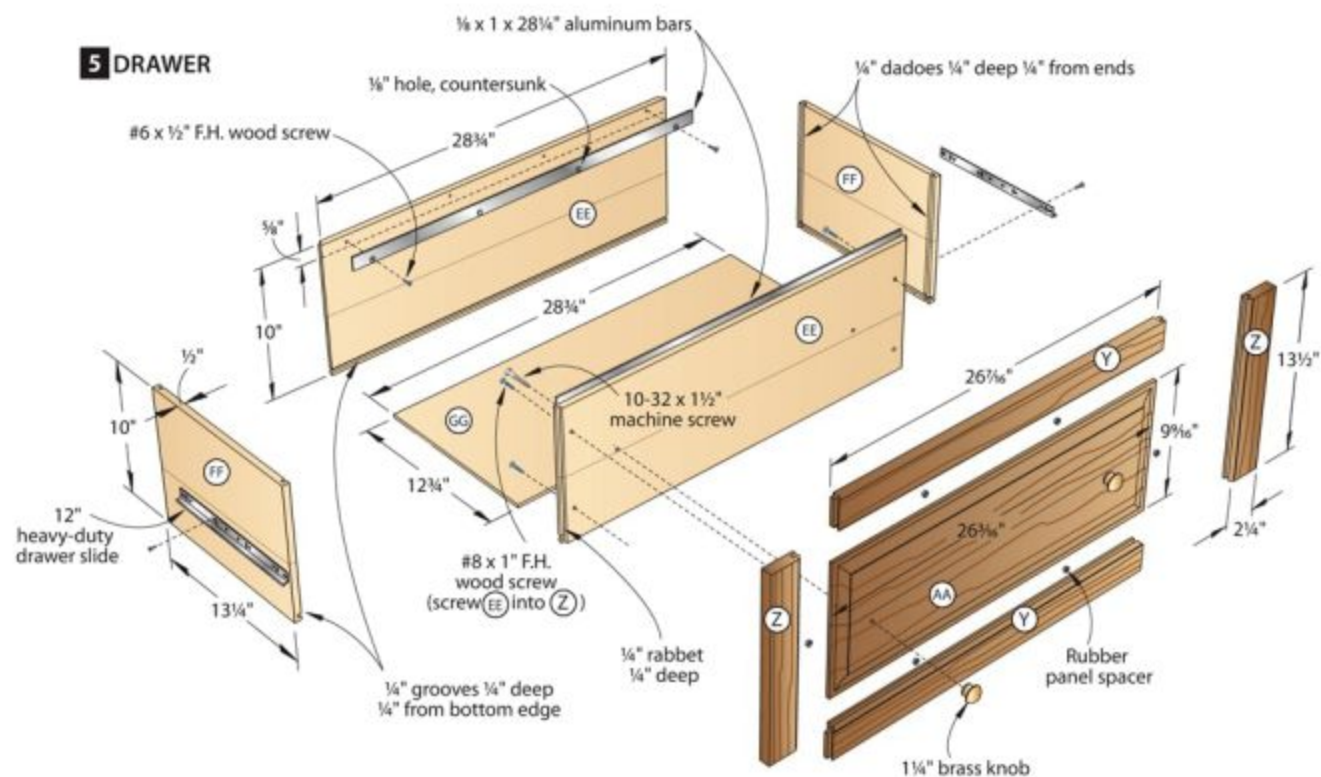

7 Cut the door stops (DD) to size [Drawing 4a]. Temporarily attach a rubber bumper to each door stop using double-faced tape. Glue the stops to the shelves (H) so the front of the door rests flush with the front of the shelf edging (I). Reinstall the back (K).

Build and install a drawer

1 Glue up 1/2" stock for the drawer front/back (EE) and sides (FF). Trim the pieces to size after the glue dries.

2 In your table saw, set up a 1/4" dado blade and raise it 1/4" above the table. With the rip fence 1/4" from the blade,

5a LOCK RABBET JOINT

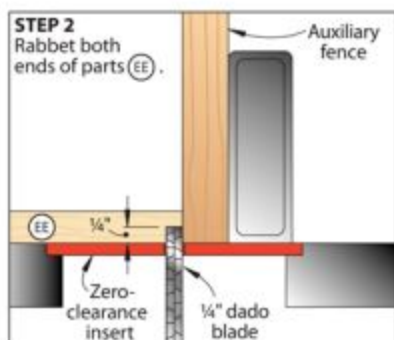
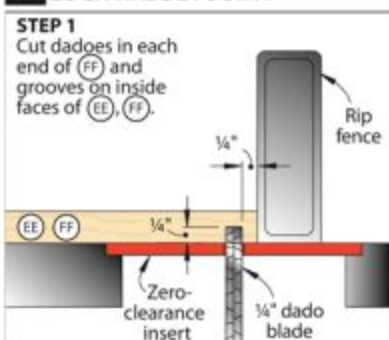



N Place $\frac{1}{4}$ " spacers below the drawer supports (CC) to bring them flush with the top face of the bottom trim (J).

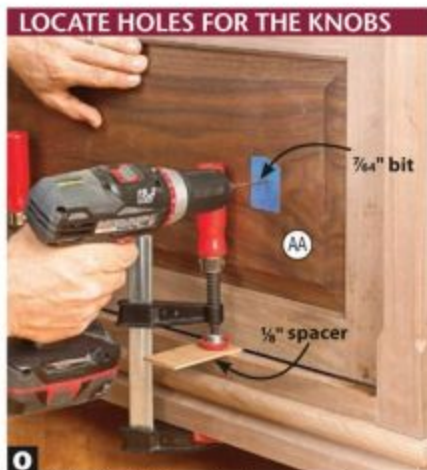

O Drill $\frac{3}{4}$ " pilot holes at the knob locations, and temporarily attach the front to the drawer with $\#8 \times 1\frac{1}{4}$ " flathead wood screws.

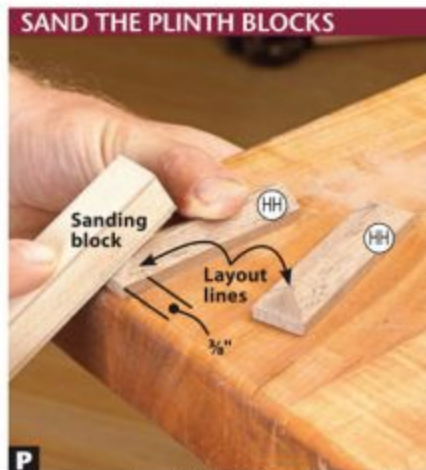

P Draw layout lines $\frac{3}{8}$ " from the ends to guide your sanding as you complete the ends of the plinth blocks (HH).

plow a dado across each end of the drawer sides (FF), and a groove to accept the drawer bottom (GG) across the inside faces of the sides and drawer front/back (EE) [Drawing 5a, Step 1]. Add an auxiliary fence to the rip fence and rabbet the ends of the front/back (EE) to create a tongue that fits the dados in the sides (FF) [Drawing 5a, Step 2]. (We demonstrate this process in a free video at woodmagazine.com/simplifiedrawer.)

3 Cut the drawer bottom (GG) to size and glue up the drawer, checking for identical diagonal measurements to ensure that the box is square.

4 Rest the drawer (EE–GG) on $\frac{1}{4}$ "-thick spacers and clamp the false front (Y/Z/AA) to the drawer, with the false front also resting on the spacers [Photo L]. Place a drawer slide along each drawer side (FF) $\frac{1}{8}$ " behind the drawer stile (Z) and resting on the bench. Use two screws to secure the slides to the drawer sides. Retrieve the drawer supports (CC) and align them flush with the false front. Transfer the location of the fronts of the drawer slides onto the drawer supports. Remove the slides from the drawer and mount them to the drawer supports [Photo M].

5 Remove the drawer slides and mount the drawer supports (CC) in the carcass [Photo N]. Then, using the screw holes in the support and drawer sides (FF), remount the drawer slides and install the drawer into the carcass.

6 Lay out the locations of the knobs on the drawer panel (AA) [Drawing 2]. (They should align with the door knobs.) Clamp $\frac{1}{8}$ "-thick spacers to the bottom trim (J) and rest the false front (Y/Z/AA) on them, centered in the opening. Drill pilot holes for $\#8 \times 1\frac{1}{4}$ " flathead wood screws [Photo O]. Drive screws through the drawer panel and into the

6 DOOR SUPPORT (left side shown, right side mirrored)

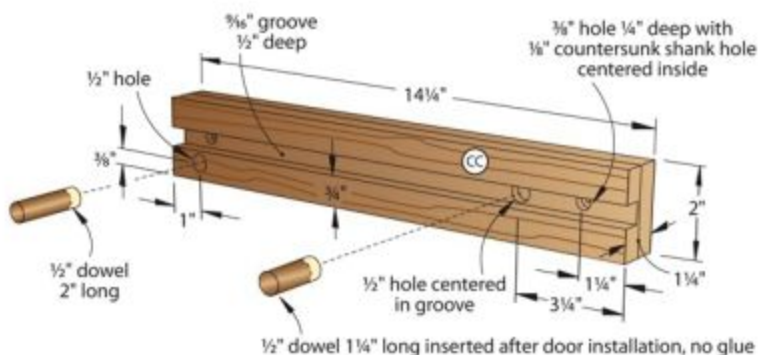

drawer front (EE). Remove the drawer and false front from the carcass, drill four countersunk pilot holes from inside the drawer into the drawer stiles (Z) [Drawing 5], and screw the false front in place. Remove the screws from the knob holes, enlarge the holes to accept $\#10$ machine screws and install the knobs.

Closing arguments

1 Cut a $\frac{3}{4} \times 4 \times 8$ " blank for the plinth blocks (HH). Rip intersecting 40° bevels along one edge, then rip a $\frac{3}{8}$ "-wide strip from the beveled edge. Cut the plinth blocks to length from this strip. Sand bevels on the ends to complete the blocks [Photo P]. Glue the plinth blocks to the facing (F) [Drawing 1].

2 Remove the back (K), doors, and drawer, and remove the false front (Y/Z/AA) from the drawer case (EE–GG). Remove the hardware, including the bumpers, from the door stops (DD). Brush a walnut stain on the carcass top/bottom (G) to blend it in with the carcass. Allow it to dry, then apply a coat of

boiled linseed oil to all unfinished pieces. After the oil cures, apply a coat of polyurethane. After the topcoat dries, buff all pieces with 320-grit sandpaper and add a second coat of polyurethane.

3 Have glass cut to size to fit in the doors. Retrieve the glass stop blanks (BB) and miter-cut pieces to fit in the rabbets [Drawing 4]. Drill $\frac{1}{16}$ " holes for the brads, place the glass in the doors, and nail the stops in place. Reinstall the doors and case back (K).

4 To accept hanging file folders, cut two pieces of $\frac{1}{8} \times 1$ " aluminum bar to fit between the drawer sides (FF) and drill countersunk $\frac{1}{8}$ " holes [Drawing 5]. Screw the aluminum to the drawer front/back (EE) with $\frac{3}{8}$ " projecting above the edge of the front and back.

5 Reattach the false front (Y/Z/AA) to the drawer and slide the drawer into the carcass.

6 If there are no objections, stock your case, then hold court to show off its features and your handiwork. 🌱

continued on page 36

Materials List

Part	FINISHED SIZE			Matl.	Qty.
	T	W	L		
carcase					
A panels	¾"	11½"	12¼"	EW	6
B top/bottom rails	¾"	2"	11½"	W	4
C center rails	¾"	2¾"	11½"	W	4
D front stiles	¾"	1½"	44¾"	W	2
E rear stiles	¾"	2¼"	44¾"	W	2
F facing	¾"	2"	44¾"	W	2
G top/bottom	¾"	14¼"	33½"	BP	2
H shelves	¾"	13½"	33½"	WP	2
I shelf edging	¾"	¾"	33½"	W	2
J top/bottom trim	¾"	1"	30¼"	W	2
K back	¾"	33½"	44¾"	WP	1
top/bottom trim frames					
L* fronts	¾"	2½"	35½"	W	2
M* sides	¾"	2½"	15½"	W	4
N* backs	¾"	2½"	30½"	P	2
extension frame					
O* front	¾"	1¼"	34¼"	W	1
P* sides	¾"	1¼"	15½"	W	2
Q* back	¾"	1¼"	32¼"	P	1
base					
R front	¾"	3½"	35½"	W	1
S sides	¾"	3½"	15½"	W	2
T corner cleats	¾"	3½"	3½"	P	6
U support cleats	¾"	¾"	2¾"	P	4
cap					
V panel	¾"	15¾"	35½"	WP	1
W* front trim	¾"	¾"	36¾"	W	1
X* side trim	¾"	¾"	16½"	W	2
door and drawer frames					
Y rails	¾"	2¼"	26½"	W	6
Z stiles	¾"	2¼"	13½"	W	6
AA drawer panel	¾"	9¾"	26½"	EW	1
BB glass stop blanks	¾"	¾"	38"	W	4
CC supports	1¼"	2"	14¼"	W	6
DD door stops	¾"	¾"	¾"	W	4
drawer					
EE front/back	½"	10"	28¾"	EP	2
FF sides	½"	10"	13¼"	EP	2
GG bottom	¾"	12¾"	28¾"	BP	1
HH* plinth blocks	¾"	¾"	3"	W	2

*Parts initially cut oversize. See the instructions.

MORE RESOURCES

FREE VIDEOS

- "Making Super-Simple Drawers" at woodmagazine.com/simplifiedrawer
- "Perfect-Fitting Dadoes" at woodmagazine.com/deadondado

FREE PLAN

- Squaring braces at woodmagazine.com/brace
- RELATED ARTICLE
- "Arts & Crafts Barrister's Bookcase" issue 149 (June/July 2003) A modular, stackable design. [S](#)

(S=Download this article from woodstore.net for a small fee. Type "barrister" in the Search box.)

Materials key: EW—edge-glued walnut; W—walnut; BP—birch plywood; WP—walnut plywood; P—poplar; EP—edge-glued poplar.

Supplies: Double-faced tape, #8x1½" flathead wood screws (8), #8x1¼" flathead wood screws (36), #8x1" flathead wood screws (4), #8x¾" flathead wood screws (18), #6x½" flathead wood screws (8), #17x1" brads (24), ½x9¾x26½" single-strength glass (2), ½x12" dowel, ½x1x36" aluminum bars (2).

Blade and bits: Dado blade; rail-and-stile set, raised panel with back cutter, ½" round-over, 45° chamfer, ½" Cove, and ¾" rabbeting router bits.

Sources

Hardware: 1¼" brass knobs (6) no. A53012 EB, \$1.69; 12" heavy-duty drawer slides (2) no. KV8505 P12, \$23.62 [pair]; ½" rubber bumpers (4) no. 3MSJ5312, \$5.60 [pack of 56]; rubber panel spacers (42) no. RCR1885, \$3.00 [pack of 100]; Woodworker's Hardware, 800-383-0130, www.hardware.com

Router bits: Rail-and-stile set (Freud no. 99-260, Woodcraft no. 828792) \$99.99; raised panel with back cutter (Freud no. 99-569, Woodcraft no. 828803) \$99.99; Woodcraft, 800-225-1153, woodcraft.com

Written by **Craig Ruegsegger** with **Jeff Mertz**
Project design: **Kevin Boyle**
Illustrations: **Roxanne LeMoine; Lorna Johnson**

Cutting Diagram

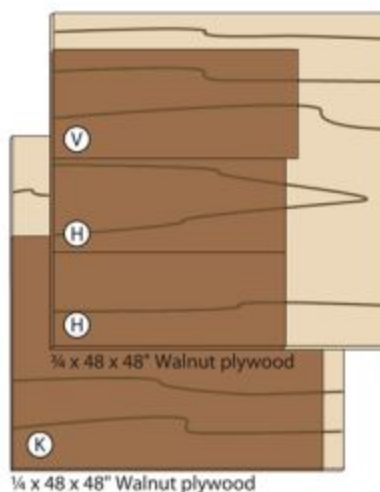
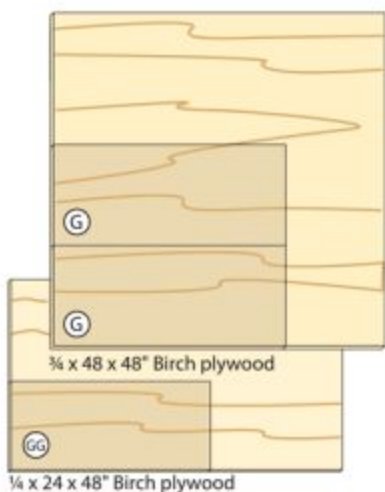
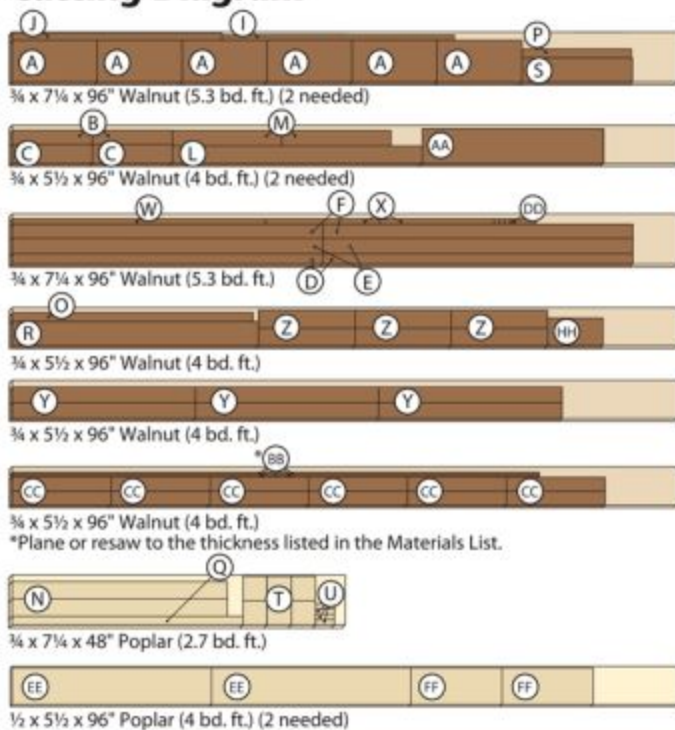

How to get the perfect Holiday gift ...

Every issue of **WOOD** Magazine on DVD-ROM!

Step 1: Fold magazine back on itself, this page up, as shown.



Step 2: Position magazine where your significant other can't miss it.



Step 3: Act surprised about receiving your ultimate Holiday gift!



25 years of **WOOD** on **5** BIG volumes —
every issue, every project, every tip,
technique, and tool review.

Get one—get 'em all—for as little as \$29.95 each!



5 Years
of issues
on each
DVD!

Hurry—quantities are limited ...
go to www.woodmagazine.com/DVDlibrary
or call 1-888-636-4478 before it's too late!



Slim-Profile TV/Game Cabinet

Give your flat-panel television or dartboard a wall-mounted hideaway that's a breeze to build.

WHAT YOU'LL NEED



■ **Materials:** 3/4" oak, 1/4" and 3/4" oak plywood, 5/16x3/4" oak molding.

PROJECT HIGHLIGHTS

- Overall dimensions: 52 3/4" wide x 8 1/2" deep x 36 1/4" high.
- The interior dimensions accept most 42" flat-screen televisions up to 49 1/2" wide x 5 1/2" deep x 32" high.
- Make a half-size version to conceal a standard-size dartboard.
- Build the doors without the expense of cope-and-stick router bits.

As bulky tube-style TVs gradually disappear, so go the old-style armoires and entertainment centers that held them. Today's televisions require smaller, sleeker storage—the kind you can build yourself using basic tools and home-center materials.

In this article, we'll first take you through the steps to build the TV cabinet. Then, on *page 43*, you'll learn about the minor modifications necessary to construct a matching dartboard case.

Assemble the case

1 Cut the top and bottom (A), sides (B), and hanging cleats (C) to size [**Materials List**, *page 42*]. **Quick Tip!** *A hang-up without hang-ups.* To make the hanging cleat fit snugly within the case, cut the cleat with the table saw setup used to cut the top and bottom to length.

2 From the outside face, drill and pocket-screw the bottom (A) 1/2" from the bottom ends of the sides (B) [**Drawing 1**]. Then pocket-screw the top (A) to



BASIC-BUILT

GREAT PROJECTS MADE SIMPLE.



Build the cabinet with two or four doors, depending on what's inside. Chalkboard-painted panels inside the dartboard cabinet doors provide a place to keep score.

with the stiles overlapping the sides by $\frac{1}{8}$ " [Drawing 1a, Photo B].

6 Cut two 54"-long blanks for the top/bottom front trim (F), a 38"-long blank for the top/bottom end trim (G), one 56"-long blank for the front cap trim (H), and a 22"-long blank for end-cap trim (I). **Quick Tip! Rout, then cut to size.** You can machine long parts easier and safer than short ones, so rout profiles on the end trim and end-cap trim before cutting them to length. Rout $\frac{1}{2}$ " coves on the top/bottom front trim and top/bottom end trim. Rout $\frac{3}{8}$ " beads on the front cap and end-cap trim [Drawing 1a]. Sand trim parts to 180 grit.

7 Miter the top and bottom front trim (F) to length. Center, drill, and screw the front trim pieces on the case (A-E) with a $\frac{1}{4}$ " front overhang.

8 Cut the top/bottom end trim (G) about 1" oversize and miter one end to make two left and right parts. Mark and cut one top/bottom end trim [Draw-

CLAMP CASE PARTS IN POSITION



Clamps keep the top and bottom (A) from moving while drilling and driving pocket-hole screws into the sides (B).

ing 1, Photo C]. Then glue and screw it to the case (A-F) [Photo D]. Repeat for the other end trim and the front-cap trim (H) and end-cap trim (I).

the sides, keeping the ends and edges flush [Photo A].

3 Screw the cleats (C) to the top and bottom (A) and drive pocket screws from the cleats into the sides (B). (For the #8 screws in this project, drill $\frac{1}{8}$ " pilot holes.)

4 Cut the face-frame stiles (D) and rails (E) to size. Pocket-screw the rails to the stiles.

5 Glue and clamp the frame (D/E) flush with the top of the case (A/B/C),

ATTACH THE FRAME TO THE CASE



Raise the case (A-E) on riser blocks to provide clearance for the clamps. This also makes it easier to use an assortment of clamps.

1 TV CABINET EXPLODED VIEW

1a CABINET FRONT VIEW

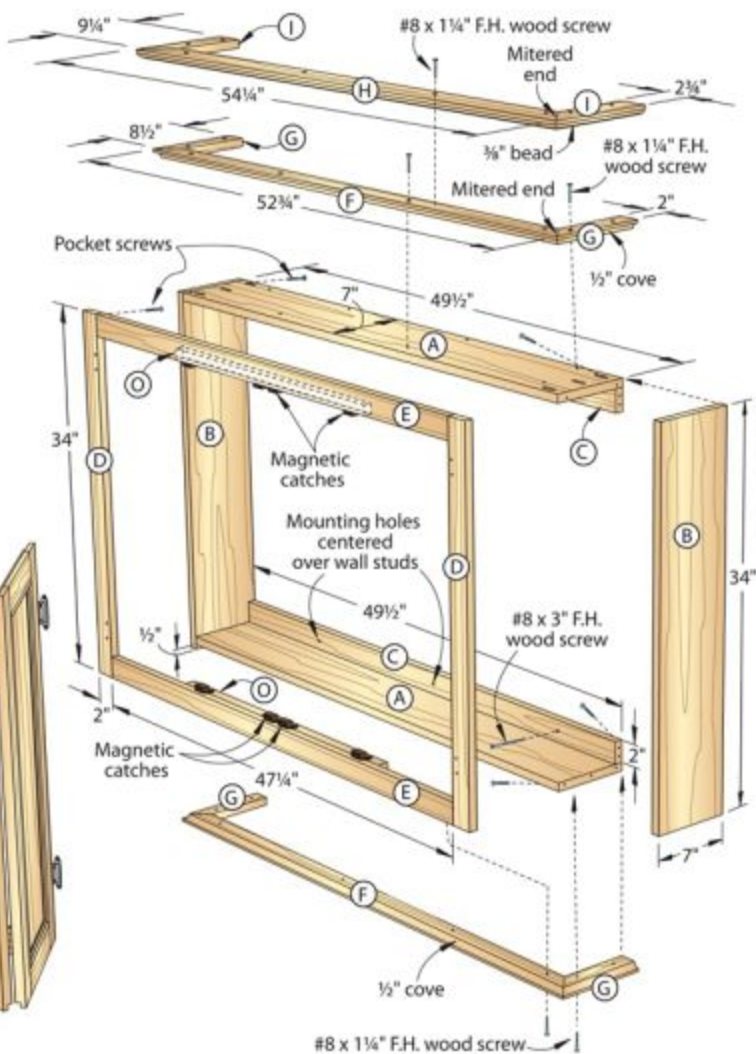
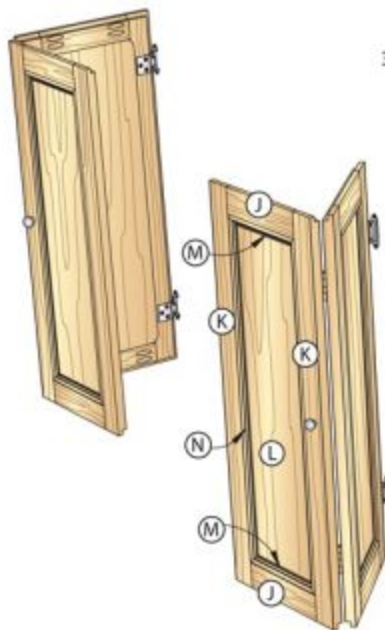
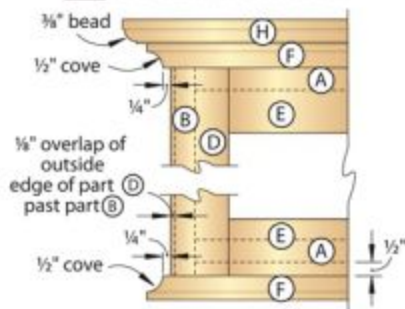

Make two pairs of doors

1 Cut the door rails (J) and stiles (K) to size. Attach the rails to the stiles by drilling and driving two pocket-hole

screws [Drawing 2]. **Note:** Place pocket-hole screws at least $\frac{11}{16}$ " from the edges of the rails to keep them clear of rabbets to be routed later [Drawing 2a].

2 Install a $\frac{1}{4}$ " rabbeting bit and make several progressively deeper passes to rout a rabbet $\frac{1}{4}$ " deep around the inside edges of the door frame (J/K).

CUT THE TRIM TO LENGTH



C With the top/bottom end trim (G) miter against the front trim (F), mark the end trim at the edge of the top/bottom (A).

ATTACH END TRIM TO THE CASE



D Drill countersunk $\frac{1}{8}$ " pilot holes in the top/bottom end trim (G) and pilot holes in the sides (B) before gluing and screwing them.

ROUND OFF PANEL CORNERS



E Use a template from an art or office supply store to mark corner radii on the door panels (L) to match the door-frame (J/K) rabbets.

2 DOUBLE-DOOR ASSEMBLY

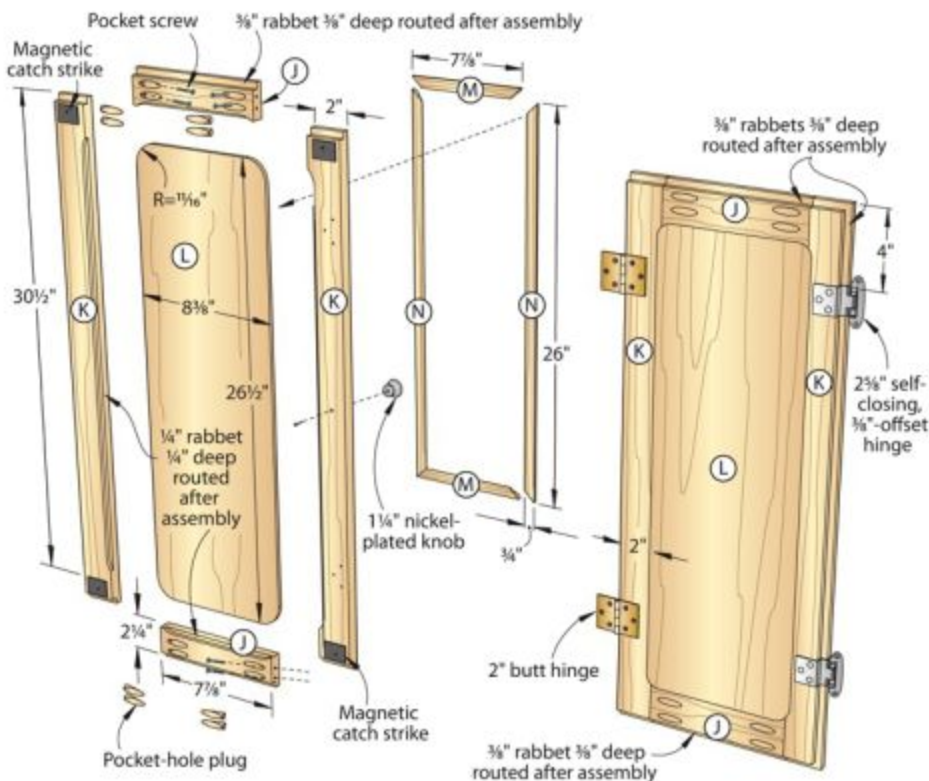

2a DOOR DETAIL

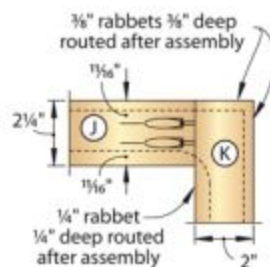

2b DOOR TRIM PROFILE

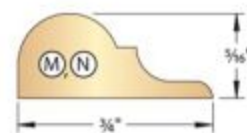

3 Cut four door panels (L) to size. Mark an $1\frac{1}{16}$ " radius at each corner [Photo E] and sand to the lines until they fit between the rabbets [Photo F]. Finish-sand the panel faces to 180 grit, then apply a thin bead of glue to the frame rabbet and clamp the panels in place or use two $\frac{3}{8}$ " brads to secure each panel.

4 After the glue dries, cut the door horizontal trim (M) and vertical trim (N) 1" oversize from molding like that in Drawing 2b. (We bought ours at a local home center.) Miter one end of

each trim part, then miter each trim part to fit the door frame [Photo G]. Glue and clamp the trim in place.

5 Rout $\frac{3}{8}$ " rabbets on the ends of all doors. On the two doors that will receive hinges, rout an additional rabbet along the door edge that hinges to the frame stiles (D) [Drawing 2].

Assemble the cabinet

1 Lay one outside door (J-M) side by side with one inside door and space them apart using folded business cards.

Center a 2" butt hinge over the gap, then drill and fasten the hinge in place [Photo H]. Repeat for the other hinge, and again for the other double door.

2 Drill and screw the $\frac{3}{8}$ "-offset hinges to the rabbeted door stile (K) of an outside door (J-M). Center the double doors between the frame rails (E). Then drill and screw the hinges to a frame stile (D) [Photo I]. Repeat for the other double door. **Quick Tip! Shrink doors to fit.** If the two inner doors bump when closed, cut them some slack on

INSERT THE DOOR PANELS



F Sanding the panels (L) before they're glued in place eliminates the problem of sanding in tight corners.

MARK MITER LOCATIONS ON TRIM



G By scribing the outside edge of the door trim (N) with a crafts knife instead of a pencil, you can miter the end for an exact fit.

MOUNT HINGES TO THE DOORS



H Center and screw on the hinges between two doors separated by a folded business card that acts as a spacer.

your tablesaw. Note the amount of door overlap, then remove the hinges from both doors. Adjust your tablesaw to remove half the overlap from the adjoining door stiles. Then reassemble the double doors and recheck the fit.

3 Cut the magnet blocks (O) to size; then glue and clamp them to the frame rails (E), centered from side to side and flush with the rail edges [Drawing 1]. Drill and screw magnetic catches to the blocks; then drill and screw knobs and strike plates to the doors (J-M).

4 Remove the hardware, fill the pocket holes in the doors with plugs, and sand smooth. Then sand all parts to 180 grit and finish. We applied Varathane no. 209 Golden Pecan stain and two coats of Old Masters water-based finish.

5 Reattach the hardware and mount the cabinet on a wall where you'll hang the television by screwing through the hanging cleats (C) into wall studs. Mount the television using tips in the sidebar *Wire Your TV Like an Expert*, and close the doors on a successful project.

FASTEN HINGES TO THE CASE



1 With rabbets on the centered double doors resting on the frame stile (D) and rails (E), drill and drive hinge screws.

Cutting Diagram



1/4 x 48 x 96" Oak-veneer plywood



3/4 x 7 1/4 x 96" Red oak (5.3 bd. ft.)



3/4 x 7 1/4 x 96" Red oak (5.3 bd. ft.)



3/4 x 7 1/4 x 96" Red oak (5.3 bd. ft.)

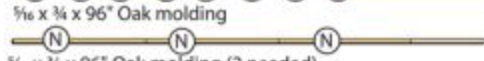

1/16 x 3/4 x 96" Oak molding (2 needed)

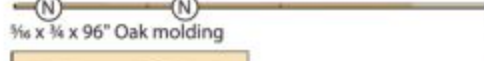

1/16 x 3/4 x 96" Oak molding



1/4 x 48 x 48" Oak-veneer plywood

Materials List (TV Cabinet)

Part	FINISHED SIZE			Matl.	Qty.	
	T	W	L			
Case						
A	top/bottom	3/4"	7"	49 1/2"	OP	2
B	sides	3/4"	7"	34"	OP	2
C	hanging cleats	3/4"	2"	49 1/2"	O	2
D	frame stiles	3/4"	2"	34"	O	2
E	frame rails	3/4"	2"	47 1/4"	O	2
F*	top/bottom front trim	3/4"	2"	52 3/4"	O	2
G*	top/bottom end trim	3/4"	2"	8 1/2"	O	4
H*	front-cap trim	3/8"	2 3/4"	54 1/4"	O	1
I*	end-cap trim	3/8"	2 3/4"	9 1/4"	O	2
Doors (4)						
J	rails	3/4"	2 1/4"	7 3/8"	O	8
K	stiles	3/4"	2"	30 1/2"	O	8
L	panels	3/4"	8 3/8"	26 1/2"	OP	4
M*	horizontal trim	1/16"	3/4"	7 3/8"	O	8
N*	vertical trim	1/16"	3/4"	26"	O	8
O	magnet blocks	3/4"	3/4"	30"	O	2

*Parts initially cut oversize. See the instructions.

Sources

Materials key: OP—oak-veneer plywood, O—red oak.
Supplies: Pocket screws, #8x1 1/4" flathead wood screws, #8x3" flathead wood screws, knobs (2), 2" butt hinges (4), 3/8"-offset hinges (4), magnetic catches (8), pocket-hole plugs, 1 1/4" nickel-plated knobs (2).

Bits: 1/4" rabbeting bit, 3/8" rabbeting bit, 3/8" round-over bit, 1/2" cove bit, pocket-hole drill bit and jig.

Wire Your TV Like an Expert

Before you mount your television cabinet, plan how you'll wire it for electricity, antenna, cable, speakers, and add-ons such as a DVD player. This can be as simple as installing a wiring chase from the TV cabinet to the baseboard or as sophisticated as running in-wall wiring.

For help with this, we turned to the online Learning Center at Crutchfield, a mail-order and retail electronics specialist. Learning Center topics include everything from audio/video basics to installing home-theater systems. To get you started, we worked with Crutchfield to bring you these Learning Center tutorials:

• **Tips and Techniques for Home A/V Cable Management** covers how to conceal wires behind raceway channels without in-wall wiring. Visit woodmagazine.com/cables

• **A Guide to Wall-Mounting Your Flat-Panel TV** explains in detail how to safely attach a flat-panel television to the wall behind your new cabinet. Visit woodmagazine.com/flatpanel

• **In-Wall Wiring Guide** explains how to run wires and cables within walls. Visit woodmagazine.com/inwallwiring

• **TV Connections** helps you make sense of ports on the back of today's televisions and describes which types of cables give you the highest quality picture and sound. Visit woodmagazine.com/connect

• To explore topics ranging from how to shop for a high-definition TV to creating a home theater, visit the Crutchfield Learning Center at crutchfield.com

Build a dartboard cabinet that scores a bull's-eye

Make an open-back dartboard cabinet using most of the same techniques and parts as the television cabinet.

1 Cut the parts to size where noted [Materials List], as with the television cabinet. Note that you'll make only two single doors this time and no magnet block [Drawing 3]. Instead, you'll add two chalkboard panels (P).

2 Assemble the cabinet (A/B/C) and frame (D/E) as before. Attach the front and end trim (F, G) to the top and bottom, followed by the front and end-cap trim (H, I).

3 Make two single doors (J–N) like the outside doors on the TV cabinet. Cut the chalkboard panels (P) to size and cover the front face with two coats of chalkboard paint [Sources]. Then center, glue, and clamp a chalkboard panel to the inside panel of each door.

4 Mount hinges on the doors and fasten them to the stiles (D). Sand where needed up to 180 grit and finish as desired. Hang a dartboard with its bull's-eye the regulation 5'8" above the floor and center the cabinet over the dartboard. Screw it through the hanging cleats (C) and into the wall studs. 🌲

3 DARTBOARD CABINET EXPLODED VIEW

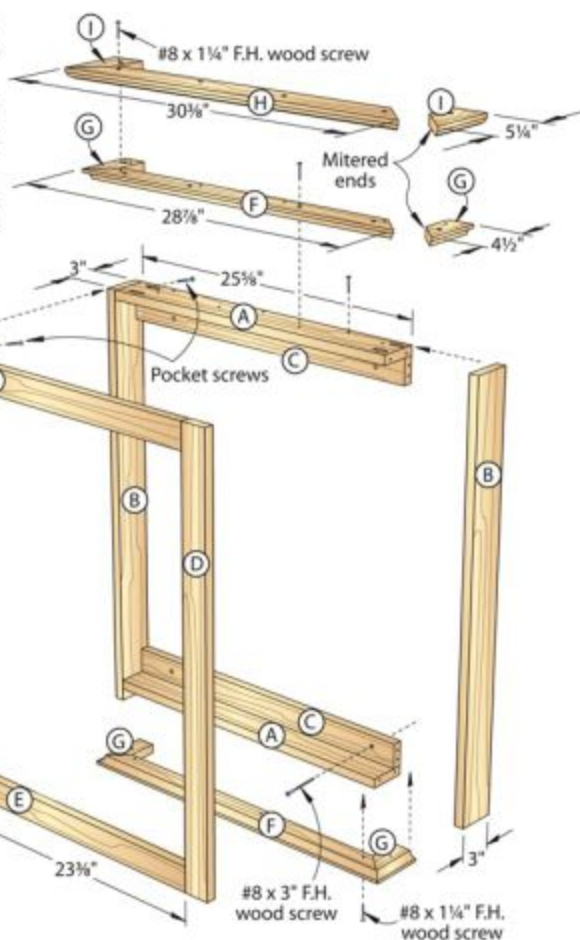

MORE RESOURCES

RELATED VIDEO

■ "Digital TV Antennas and Installation" at [\\$">woodmagazine.com/DigitalTV. \\$](http://woodmagazine.com/DigitalTV) (\$=Download this video for a small fee.)

Cutting Diagram

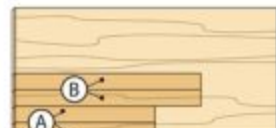

1/4 x 24 x 48" Oak-veneer plywood



1/4 x 24 x 48" Oak-veneer plywood



3/4 x 24 x 48" Hardboard



3/4 x 5 1/2 x 96" Red oak (4 bd. ft.)

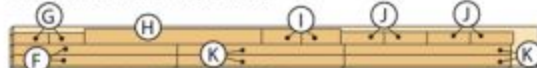

3/4 x 7 1/4 x 96" Red oak (5.3 bd. ft.)



3/8 x 3/4 x 96" Oak molding



3/8 x 3/4 x 96" Oak molding

Written by **Bob Wilson** with **Kevin Boyle**
Project design: **Jeff Mertz**
Illustrations: **Roxanne LeMoine; Lorna Johnson**

Sources

Materials key: OP—oak-veneer plywood, O—red oak, HB—hardboard.
Supplies: Pocket screws, #8x1 1/4" flathead wood screws, #8x3" flathead wood screws, knobs (2), 3/8"-offset hinges (4), pocket-hole plugs, 1 1/4" nickel-plated knobs.
Bits: 1/4" rabbeting bit, 3/8" rabbeting bit, 3/8" round-over bit, 1/2" cove bit, pocket-hole drill bit and jig.
Sources: Blackboard paint no. 203261, \$12 per quart, available at Lowe's stores. Or use Rust-Oleum no. 206540 chalkboard paint, \$15 for 30 oz., from Amazon.com.

Materials List (Dartboard Cabinet)

Part	FINISHED SIZE			Matl.	Qty.	
	T	W	L			
Case						
A	top/bottom	3/4"	3"	25 1/2"	OP	2
B	sides	3/4"	3"	34"	OP	2
C	hanging cleats	3/4"	2"	25 1/2"	O	2
D	frame stiles	3/4"	2"	34"	O	2
E	frame rails	3/4"	2"	23 3/8"	O	2
F*	top/bottom front trim	3/4"	2"	28 7/8"	O	2
G*	top/bottom end trim	3/4"	2"	4 1/2"	O	4
H*	front cap trim	3/4"	2 3/4"	30 3/8"	O	1
I*	end cap trim	3/4"	2 3/4"	5 1/4"	O	2
Doors (2)						
J	rails	3/4"	2 1/4"	7 7/8"	O	4
K	stiles	3/4"	2"	30 1/2"	O	4
L	panels	1/4"	8 3/8"	26 1/2"	OP	2
M*	horizontal trim	3/8"	3/4"	7 7/8"	O	4
N*	vertical trim	3/8"	3/4"	26"	O	4
P	chalkboard panels	1/4"	8 3/8"	27"	HB	2

*Parts initially cut oversize. See the instructions.

AWARD-WINNING DESIGN

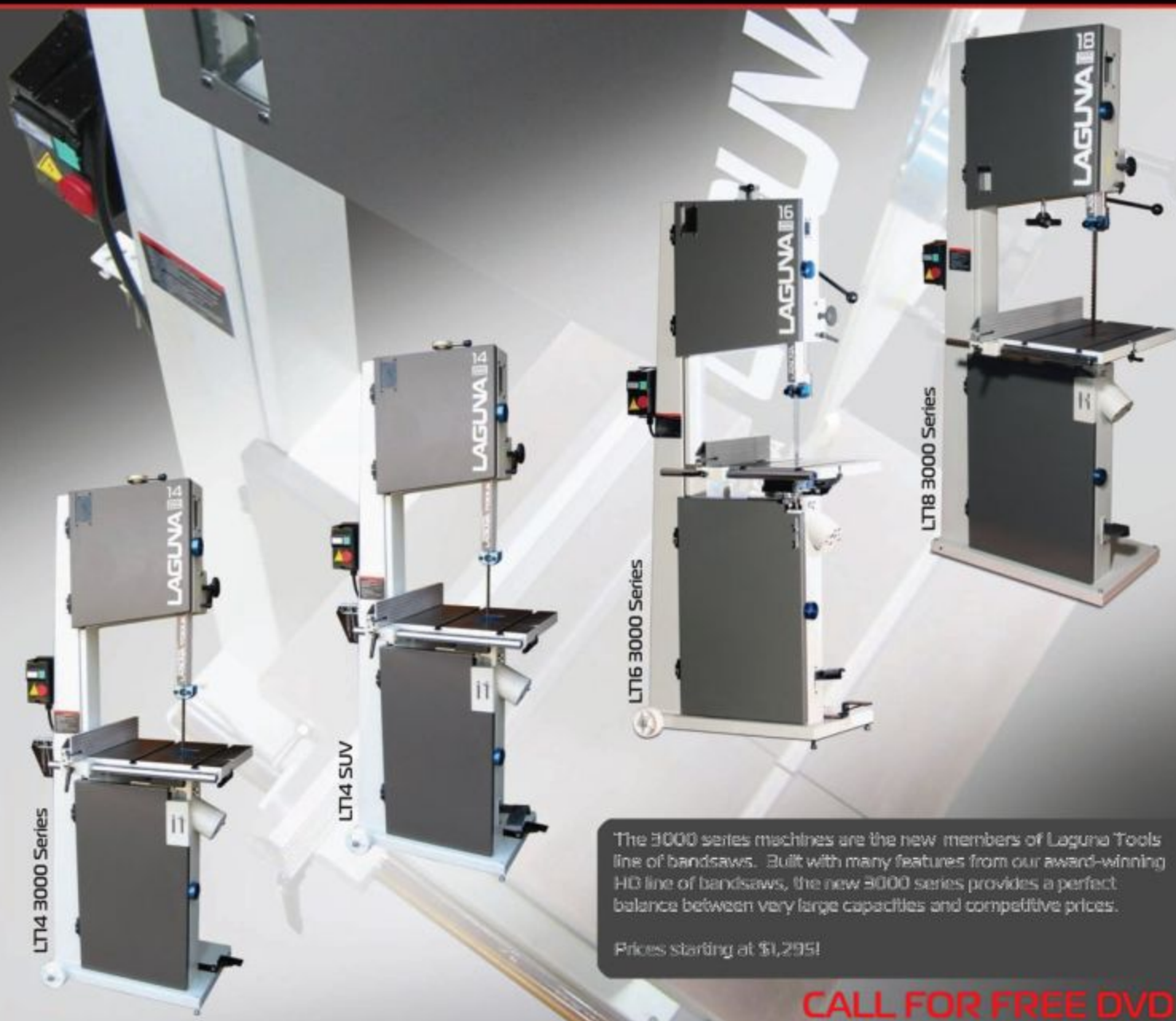

The 3000 series machines are the new members of Laguna Tools line of bandsaws. Built with many features from our award-winning HD line of bandsaws, the new 3000 series provides a perfect balance between very large capacities and competitive prices.

Prices starting at \$1,295!

CALL FOR FREE DVD

TABLESAW

Platinum Series Dovetail



3-hp TEFC Leeson Motor
10-in. Blade Capacity
50-in. Rip Capacity
Triple V-Belt Drive System

JOINTER

Platinum Series 8-in.



2-hp TEFC Motor
1/8-in. Cut Capacity
Shear-Tec Spiral Cutterhead

PLANER

Platinum Series 20-in.



5hp TEFC Motor
25-in. x 20-in. Table
Shear-Tec Spiral Cutterhead

PANELSAW

Pro Series 6 Sliding Table



4-hp TEFC Motor
1/2-hp Scoring Motor
67-in. Gross Cut Capacity
10-in. or 12-in. Blade Capacity

THRIVING ON INNOVATION
LAGUNA TOOLS
1701 Murphy Avenue, Irvine, CA, 92614

www.lagunatools.com

Se Habla Español
800.234.1976
949.474.1200



PROJECTS

Article, Issue: Page

Air compressor caddy, 190:52-55
 Bedroom set, Shaker-style, 187:24-39
 Benchtop risers, 193:24, 26
 Blanket chest, 194:30-36
 Bookcase, glass-door, 191:34-40
 Bud vase, 194:28-29
 Cabinets, basic, 191:50-55
 Candleholder, 191:20-21
 Circular saw cutting guide, 191:26
 Clamp racks:
 Adjustable, 191:56-58
 Hold by handles, 194:18
 Shelf-style, 193:75
 Clock, mantel, 194:54-56
 Cope-cutting sled, 191:32
 Desk, drop-front, 193:32-38
 Dowel drilling jig, 189:72

Article, Issue: Page

Dresser, Shaker-style, 188:34-40
 Dust collection floor chute, 188:10
 Excavator, toy, 194:62-65
 Ice cream scoop, turned-handle, 191:76-78
 Jewelry chest, 191:70-75
 Lingerie chest, Shaker-style, 189:34-40
 Magazine file, 193:66-68
 Mirror, Shaker-style, 188:66-68
 Music box, 192:47-51
 Napkin holder, 189:20
 Organizer, wall-hung, 189:49-53
 Picnic table, 191:60-65
 Printer stand, 192:66-69
 Quilt ladder, update, 189:6
 Rocking horse, 193:50-53
 Router table, 192:56-61
 Saddle jig, for cutting tall pieces on tablesaw, 192:70

Article, Issue: Page

Sanding-disc caddy, 189:32
 Sandpaper cutter, 190:85
 Shelf and towel rack, 192:34-37
 Shelf-pin drilling jig, 191:24
 Shelves, stacking, 189:70-74
 Table, Arts & Crafts, Limbert, 192:30-33
 Table set: coffee, end, sofa, 188:54-60
 Table-leg trimming jig, 189:30
 Tapering jig, 188:12
 Telephone stand, 190:62-65
 Tool tote, toy, 190:76-77
 Towel rack and wall shelf, 192:34-37
 Tree bench, 190:38-44
 Valet, dresser-top, Shaker-style, 188:41-43
 Wine rack, 188:62-64
 Work table, folding, 190:32
 Workbench, 194:42-44

TOOLS & MATERIALS

Article, Issue: Page

Air-filtration system, Powermatic, test, 192:77
 Bandsaw, adjustable height, General International, 188:30
 Bandsaw, Steel City, test, 189:16
 Bandsaw, update, cutting steel, 188:8
 Bandsaw blade, how to coil, 191:18-19
 Bandsaw blade oscillation, 193:84
 Basic power tools, best, 190:34-37
 Circular saws: Makita, Skil, 190:34
 Circular saws, rail-guided, test, 192:62-65
 Clamps, parallel-jaw, Bessey, 188:30
 Clamps, parallel-jaw, Irwin, test, 194:74
 Contour sanders, Style-Line Corp., test, 194:76
 Coping sleds for router table, test, 191:30
 Dado sets, test, 188:50-53
 Doweling joiner, Freud, 188:29
 Drill/drivers: Hitachi, Makita, 190:36
 Drill/drivers: Ridgid, Ryobi, 188:30
 Drum sander, oscillating, Jet, 188:30; test, 193:78
 Drum sanders, test, 190:49-51
 Dust collector, portable cyclone, Oneida, test, 190:82

Article, Issue: Page

Dust collectors, portable cyclone: JDS, Oneida, 188:32
 Forstner bit sets, test, 194:20
 Gator Micro Zip Sander, Ali Industries, test, 193:80
 Glues, best for outdoor, test, 190:72
 Granite-enhanced machines, 189:16
 Hinge-boring Jig, Sommerfeld, test, 191:80
 Innovations of the past 25 years, 193:58-62
 Jigsaw blades, Bosch, 188:32
 Jigsaw blades, Starrett, test, 192:78
 Jigsaws: Black & Decker, Bosch, 190:37
 Jointer, Steel City, test, 189:16
 Jointer knives, Dispozablade, test, 193:82
 Jointer/planer combos, test, 191:66-68
 Jointers, test, 189:54-59
 Lathe, Laguna Tools, test, 194:72
 Magswitch, 188:32
 Mittersaw, dual compound/sliding, Milwaukee, 188:30
 Mittersaw, dual-bevel, Milwaukee, test, 193:80
 Mittersaw, sliding compound, Bosch, test, 191:80
 MiterSet, Richard L. Pattee, test, 191:83
 Mortise Mill, JessEm, 188:32

Article, Issue: Page

Nailer/compressor combo kits, test, 190:30
 Nail-puller, Extractor, test, 189:19
 Outlet, rotating, 360Electrical, test, 190:84
 Painter's Pyramids, test, 192:77
 Planer/jointer combos, test, 191:66-68
 Random-orbit sander, Milwaukee, 190:37
 Right-angle assembly squares, test, 193:22
 Router bit, Double-grind straight, Freud, test, 191:81
 Router bit, tambour door set, Amana, test, 194:73
 Router-bit setup tips, 194:50-53
 Router dado jig, Infinity Cutting Tools, test, 194:76
 Router mortising jig, Mortise Pal, test, 190:82
 Router table accessories, test, 192:24:
 Featherboard, Milescraft
 Fence, Woodpeckers
 Safety switch, Rockler
 T-track/miter track, MLCS
 Router-table power switches, test, 189:28
 Routers: Bosch, Craftsman, 190:36
 Routers for table mounting, 192:26

continued on page 46

TOOLS & MATERIALS (CONT.)

Article, Issue: Page

Setup tools for machinery, 189:22, 24
Tablesaw, Craftsman, 190:35
Tablesaw, Delta Unisaw, 188:29; test, 192:76
Tablesaw, Grizzly, 190:35
Tablesaw, hybrid, Ridgid, test, 194:72

Article, Issue: Page

Tablesaw, SawStop, test, 191:80
Tablesaw, splitter vs. riving knife, 188:74, 192:6
Tablesaw blade, damaged, 194:78
Tablesaw blades less than \$50, test, 194:58-60
Tenon-Lok joinery system, Rockler, test, 193:78

Article, Issue: Page

Tenoning jigs, test, 193:69-71
Tools for fine-tuning joints, 194:24, 26
WorkSharp, update, 189:6

TECHNIQUES AND FEATURES

Article, Issue: Page

Abbreviations on Internet, 189:78
Abram, Norm, 192:38-42
Acrylic, cutting, 189:78
Baseboards and chair rails, making and installing, 194:66-70
Bevel large tabletops, 191:17
Beveled tapers, 192:22-23
Biscuit joint mistakes, 193:28, 30
Cabinet door, making and mounting, 191:53-54
Cabinetmaking basics, 191:50-55
Casters, on picnic table, 188:78
Chair rails and baseboards, making and installing, 194:66-70
Chatoyance, defined, 189:80
Consumer Product Safety Improvement Act, 191:14
Coping molding, 194:69
Dadoes, cutting on tablesaw, 188:16
Deadblow mallet, using, 190:78
Digital subscription, 190:6
Door and window trim, make and install, 193:40-44
Door contest winner, 191:12
Dovetailing wide panels, 194:38-39
Dowels, making, 194:81
Drawer, making, 191:54-55
Drawer, out of square, 194:22
Earlywood and latewood, defined, 193:83
Finishing:
 Film finish, fixes, 190:18-19, 21
 Lacquer, repair damage, 188:81
 Pine, staining, 189:81
 Shellac, all about, 192:18, 20
 Staining plywood, to match solid stock, 188:14
 Walnut, faux, 189:74
Frame and panel construction, 190:56-60
Furniture labeling, 192:74
Gloves for solvents, 190:81
Glue-up, no clamps, 188:78
Going pro, 188:70-73
Habits for shop success, 190:66-69

Card scraper, 192:55



Article, Issue: Page

Hand tools, problem solving:
 Bench chisels, 192:54
 Block plane, 192:55
 Card scraper, 192:55
 Flush-trim/dovetail saw, 192:55
 Sanding grips, 192:55
Index, issues 181 thru 187, 188:6, 45-48
Joinery:
 Bevel joints, how to, 190:22
 Beveled tapers, 192:22-23
 Biscuit joint mistakes, 193:28, 30
 Dadoes, how-to, 188:16
 Dovetailing wide panels, 194:38-39
 Dovetails, how-to tips, 188:24, 26-27
 In large parts, with circular saw, 191:26-28
 Metal fasteners, or not?, 193:18
 Mortise-and-tenon, hints, 188:63; sizing 189:76
 Outdoor adhesives, joint test, 190:72-74
 Pocket-hole, 188:57; face frame, 191:52-53
 Tools and methods for fine-tuning, 194:24, 26
Jointer, save money with, 194:40-41
Jointing and planing, how to, 189:60-63
Knots, working with, 190:28; 194:6
Lamination springback, 192:73
Lighting, shop, placement, 194:80
Metal, hidden inside trees, 191:14
Moisture content, 189:83
Norm Abram, 192:38-42
Planer, save money with, 194:40-41
Presidential gifts, 189:86
Pressure-treated lumber, safety, 189:82
Raised-panel door, how to, 190:24-26
Raised panels, movement, 194:82
Router burn marks, remove, 191:22; 194:13
Router-bit setup tips, 194:50-53
Routing small parts, 190:78
Salvaged lumber, finding and using, 193:72-74
Scrapers and parting tools, how to use, 189:42-44
Screw, removing broken, 194:78

Habits for shop success, 190:66-69



Article, Issue: Page

Screws, choosing, 191:41-43
Securing the shop, 192:72
Shellac, 192:18, 20
Shop Monkey, metal vs. wood fasteners, 193:18
SketchUp, design tips, 189:64-68
Smoke smell, removing from furniture, 192:75
Spalted maple food safety, 191:16
Splitter/riving knife, 188:74; 192:6
Staining, matching plywood and solid stock, 188:14
Story stick, 190:70-71
T-track, installing, 188:83
Table legs, fixing uneven, 189:30
Templates preserving, 189:76
Trim, make quarter round, 190:78
Turning, Doug Magrath, 188:70-73
Turning: How to use scrapers and parting tools, 189:42-44
Underwriters Laboratories, 190:79
Veneering made easy, 193:54-56
Video sources, 190:6
Window and door trim, build and install, 193:40-44
Wood grain selection, 192:72
WOOD magazine's first 25 years, 193:64-65
Wood toy regulations, 191:14
Woodworking woods:
 Bamboo, 192:53
 Cedar, aromatic, 194:16
 Combination-core plywood, 192:52
 Cypress, 194:6
 Earlywood and latewood, defined, 193:83
 Ipe, 192:53
 Lyptus, 192:52
 MDF, differences in quality, 189:80
 Padauk, 190:80
 Pine, pitch bleeding, 190:81
 Pressure-treated lumber, safety, 189:82
 Spalted maple, 191:16
 Wood grain selection, 192:72
 Wood substitutes, 192:52-53

Scrapers and parting tools, 189:42-44



Article, Issue: Page

Bandsaw blade labeling, 194:8
 Bandsaw quick-release fence, 193:15
 Bandsawing small parts, 193:83
 Baseboard moldings, miterless corners, 194:68
 Bending steel, 190:42
 Bookmatching:
 Solid stock, 191:72
 Veneer, 193:55
 Brass, working with, 191:74
 Burn marks, removing, 194:13
 Carriage bolt, prevent slipping, 192:10
 Carriage bolts, square-hole washers, 191:62
 Centerline on tapered legs, 189:10
 Chalk, keep from breaking, 194:15
 Chamfer on drawer, 192:69
 Chisel holder, magnetic, 190:16
 Circular saw, zero-clearance plate, 188:21
 Clamp without a vise, 192:32
 Clamping curved parts, 188:63
 Clamping deep, using metalworking clamps, 188:20
 Clamping flat for gluing, 188:68
 Clamps, pins through handles for leverage, 192:17
 Corner brace, 190:64
 Curved leg, cutting on tablesaw, 190:65
 Dado blade, resharpen, 188:51
 Dado width adjustment, 191:9
 Detail-sander storage, 190:17
 Dovetail, patching pin, 194:34
 Dovetail angle ratio, 194:31
 Dovetail saws, 194:33
 Dowel center-finder, 192:16
 Dowels and dowel holes, align, 189:72
 Downdraft sanding on tablesaw, 191:6
 Drill press, ratcheting handle, 192:17
 Drill press keyless chuck, 192:14
 Drill-press crank extension, 188:18
 Drill-press table realignment, 189:11
 Drilling extra-deep holes, 193:83

Article, Issue: Page

Drum sander adapter, 194:10
 Duplicating parts, 193:52
 Dust collector, hand-held router, 189: 8
 Dye, faux walnut, 189:74
 Featherboards, 193:14
 Finish, vacuum pump air out of cans, 189:15
 Finishing table, 191:6
 Fluting jig for router, 192:8
 Gauging cuts, turning, 191:77
 Glue, drive screws after, 189:52
 Glue brush and magnet, 194:11
 Glue joint, soften glue with heat, 190:17
 Glue squeeze-out, avoid, 188:35
 Grooves, centered, 189:72
 Half-lap, setup, 191:38
 Hand plane, protect sole, 194:13
 Hinge mortise template for routers, 192:50; 193:34
 Hinge mortises, routing, 189:14; 192:6
 Jigsaw blade for cleanest cutting, 192:35; 193:51
 Kerfs with flat bottoms, 192:49
 Laminate plans to preserve, 189:11
 Lathe shavings control, 190:15
 Lumber, dimensional, working with, 191:61
 Marking machined stock, 189:62
 Measurement error by multiplication, 189:12
 Miter sled for picture frames, 194:8
 Mitered corners clamp, 188:23
 Miter saw hold-down clamp, 190:14
 Miter saw safety, cutting small pieces, 191:9
 Mortise-and-tenon hints, 188:63
 Nail blowout, avoiding, 191:11
 Nail removal, 194:67
 Organizer hangs on back of door, 188:21
 Paint-roller saver, 188:23
 Panel clamps, 191:10
 Patterns, self-adhesive, 191:8
 Permanent marker on bit cases, 189:12
 Plywood thickness, 189:37

Article, Issue: Page

Pocket-hole joinery, 188:57
 Precision without a ruler, 189:51
 Pushstick for belt sander, 188:18
 Rabbets, cutting on tablesaw, 188:57
 Rabbets, using table-mounted router, 188:67
 Rabbets with handheld router, 192:36
 Rag-box holder, 193:12
 Raised-panel squeeze-out, 193:13
 Redrilling large holes, 193:13
 Repeat tasks, spacers and guides, 190:39
 Rip thin strips, 189:71; 194:12
 Rout small parts safely, 191:21
 Sander, pushstick holder, 188:18
 Sanding thin pieces, 191:8
 Sawhorse lifts sheet goods, 189:13
 Screw organizer, 192:10
 Scrollsaw blade keeper, 188:20
 Scrollsaw, changing blades, 190:14
 Setup gauge, tablesaw, 190:71
 Shelving as door on shop shelves, 194:11
 Shop tip organization, 193:12
 Splines provide support, 190:16
 Storage using jack posts, 192:12
 Story stick, 188:41; 189:10
 Stub tenons, sizing, 188:37
 Tablesaw fence, microadjuster, 190:12
 Tablesaw hold down, 194:15
 Tablesaw sawdust solution, 190:15
 Tablesaw sleds:
 For odd-shaped pieces: 193:17
 With replaceable inserts, 192:15
 Templates from plastic cutting boards, 193:10
 Threaded inserts, installing, 193:10
 Threaded rod, cutting, 194:63
 Trimming overhang edges, 189:36
 Voids, patching with epoxy, 194:44
 Zero-clearance plate, for circular saw, 188:21

Installing threaded inserts, 193:10

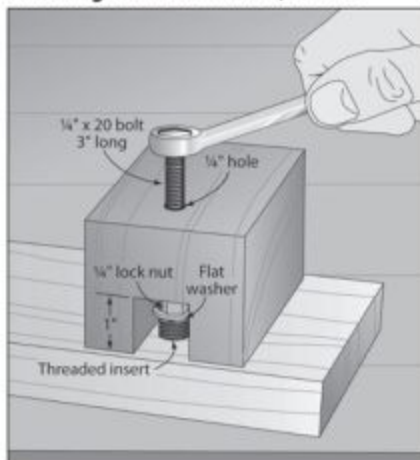

Changing scrollsaw blades, 190:14

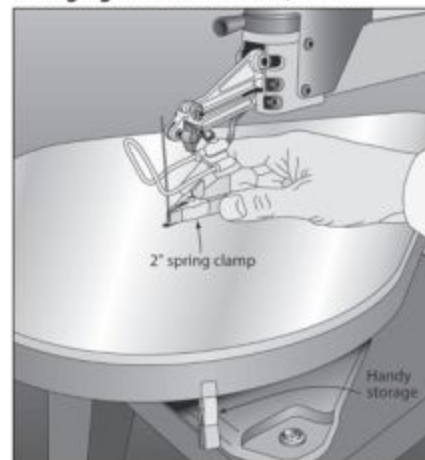

Miter saw safety, cutting small pieces, 191:9

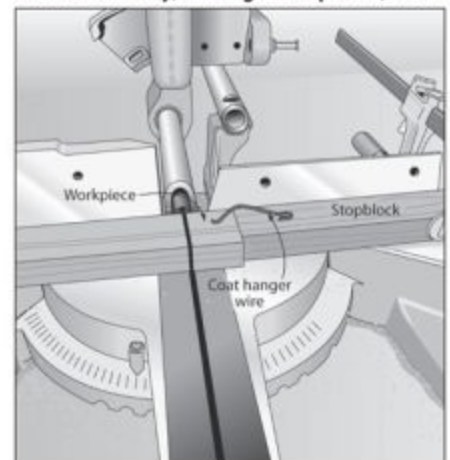

HOW TO USE THIS INDEX

This annual index includes every article and Shop Tip that appeared in *WOOD*® magazine from the December/January 2008/2009 issue through the November 2009 issue. To quickly find the article you're looking for, first identify the major index category most likely to contain the article:

- Projects (plans with step-by-step instructions)
- Tools & Materials (product reviews and guidance on using tools, accessories, hardware, and wood products)
- Techniques and Features (specific skills and articles of general interest, such as craftsman profiles)

- Shop Tips/Skill Builders (quick ideas you can put to use in your shop today)
- Then look for the one word that best describes the project, technique, tool, or shop tip. Articles with two strong descriptors, such as a mission table, may be found under both descriptors—"mission" and "table."

Three steps to find any article, from issue 1 to present, using the online index

1 You also can quickly search the comprehensive online index of all *WOOD* magazine articles in one of two ways. First, to get directly to the index, type woodmagazine.com/index in your Web browser. Or, click on the **Article Index** button, shown below, in the left column of any woodmagazine.com page.

2 In the Keyword Search box, type the *one word* that best describes the article subject, avoiding plurals. For example, to locate a tablesaw review, type "tablesaw," (or simply "table") but not "review." Click on the button marked **Search**. If you want to narrow the search to tablesaw jigs, type "tablesaw" in the box, then click on the button next to the words: **Jigs, Fixtures, & Organizers** under Category Search. Next, scroll down and click on **Search** under Keyword and Category Search.

3 The Web page now displays a list of articles related to your search term, including the cover date of the issue, issue number, and the page numbers. If you don't have the issue, most articles published in *WOOD* magazine can be downloaded for a minimal cost. This list indicates downloadable articles with the blue words **WOOD STORE**, which, when clicked on, give you more details about buying the article. Otherwise, some back issues are available for \$7.95 (plus s&h) by calling 888-636-4478.



Keyword Search 'tablesaw' and Category Search 'Jigs, fixtures & organizers'
41 articles from WOOD magazine matched the search criteria you entered.

Article	Month	Year	Issue No.	Page
Fine-furniture accuracy from any tablesaw	Nov	2008	187	40
This article available at the WOOD STORE				
Quick, clean rabbets on the tablesaw	May	2008	183	34
Tablesaw Blade Locker	May	2008	183	80
Plans available at the WOOD STORE				
Zero (Chip-Out) Tolerance	Mar	2008	182	28

Not sure exactly what project plan you're looking for? Go window shopping!

So, you've had a request from a family member to build a project—say, a piece of mission-style furniture. Where do you start? Go to the *WOOD* Store® at woodstore.net and click on the tab that best describes the article you want (**Plans**, **Techniques and Features**, or **Tool Reviews**). Staying with the mission furniture example, you next click on **Projects**, and on the next page **Indoor Furniture and Accessories**, and then **Arts and Crafts Furniture, Mission Style** on the next page. There, you'll find more than 30 mission-style projects.





*Put Some **Metal** In Your Wood*

The PlasmaCAM® machine makes it easy for you to cut intricate metal shapes that really enhance your wood projects.



Call today for your FREE demo video to see what you can do with this amazing machine.

(719) 676-2700 • www.plasmacam.com
PO Box 19818 • Colorado City, CO 81019

Plasma
CAM

Chip & Dip Tray



Learn new router skills as you build this fun, useful snack server.

Passing the snacks at your next party might be a problem as guests pause to admire the contrasting woods and flowing lines of this chip and dip holder. When guests ask for snack trays of their own, make copies in no time using templates.

Assemble a tray blank

1 Starting with stock about $\frac{1}{4}$ " thicker than shown in the **Materials List**, page 52, edge-glue three panels to create blanks for the tray top and bottom (A) and middle (B). After the glue dries, plane the blanks to thickness.

2 To distribute clamping pressure to the center of your lamination, cut six 2×12 " clamping cauls and lay out a curve on one edge of each with the center of the faces $\frac{1}{8}$ " wider than the ends [Drawing 1]. Cut or sand each caul to the layout line.

3 Stand three pairs of clamps on your bench with cauls spanning the lower jaws, curved edge up [Photo A]. Glue and sandwich the tray middle (B) between the tray top and bottom (A) with the ends and edges flush. Place the remaining cauls curved side down on top of the

tray parts between the pairs of upper clamp jaws. Tighten the clamps until the ends of the cauls touch the blank.

Templates for success

1 Cut two $\frac{1}{2} \times 11 \times 17$ " pieces of MDF or Baltic birch plywood for the templates. Enlarge the tray pattern [Drawing 2] 400 percent to make two full-size photocopies. Or if you prefer to trace the

layout on the template blanks, first make a beam compass using $\frac{1}{2}$ " MDF or plywood [Drawing 3].

2 Lay out centerlines on each template and mark each radius where shown [Drawing 2]. Use the beam compass to trace arcs [Photo B]. Label one template as "inside" and the other as "outside."

3 On the inside template, cut out the openings about $\frac{1}{16}$ " from the lines

LAMINATE THE TRAY PANELS



A Cauls evenly distribute clamping pressure from the edges to the center of the glue-up. Arrows on the cauls mark the curved edges.

TRACE CURVES FOR THE TRAY



B After marking centerlines on the templates, mark the centers of curves. Use the beam compass to draw connected arcs.

EXTEND YOUR BIT'S REACH



F A collet extension adds 2½" to the shank of this tray bit, allowing it to reach past the template and 2½" into the tray openings.

ROUT A FLAT-BOTTOMED TRAY



G After a series of ¼"-deep cuts, the final pass reveals the contrasting walnut portion of the tray blank (A/B).

ROUT THE INSIDE ROUND-OVERS



H Place the tray upside down over your round-over bit and rout the inside edges of each tray opening.

depth so the bearing will ride against the template edges and the bit cuts only the blank. Rout around each tray opening and remove the chips.

2 Reset the router plunge depth so that the bearing rides against the edge of the previous cut. Then make a second pass. Repeat until the bit cuts 2½" deep [Photo G]. (Center the lamination line on the bit radius.) Now rout the centers to flatten the bottoms of the openings.

3 Remove the inside template, place the outside template in position and trace the tray shape on the blank (A/B). Bandsaw the tray and sand to 320 grit.

4 Install a ¼" round-over bit in a table-mounted router and set it to round

over the inside edges of each tray opening [Photo H, Drawing 4]. Then round over the top and bottom outside edges [Photo I]. **Quick Tip! No table needed.**

If you don't have a router table, use the auxiliary router subbase to stabilize the router as you round over the edges freehand.

5 Sand the edges and insides of the compartments up to 320 grit using sanding sponges. Apply three coats of satin polyurethane, sanding with a 320-grit sanding sponge between coats. Then invite some friends over, stock the tray with chips and let the party begin. 🍷

ROUND OVER THE OUTSIDE EDGES



I Turn the tray counterclockwise as you run the edges against the ¼" round-over bit bearing.

4 ASSEMBLED TRAY

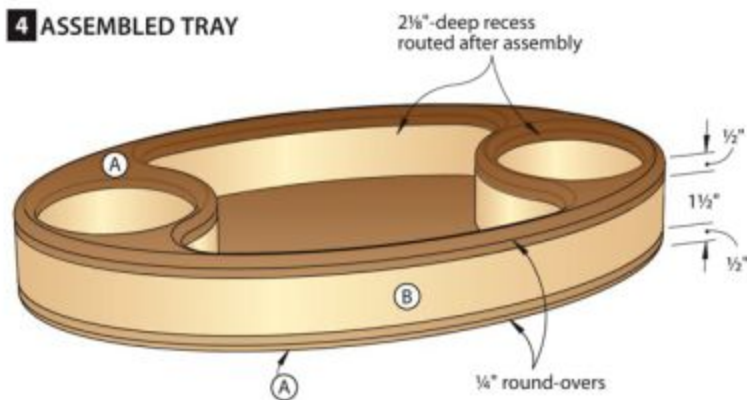

Materials List

Part	FINISHED SIZE			Matl.	Qty.
	T	W	L		
A* tray top/bottom	½"	11"	19"	W	2
B tray middle	1½"	11"	19"	M	1

*Parts initially cut oversize. See the instructions.

Materials key: W—edge-glued walnut, M—edge-glued maple.

Bits: 1¼"-diameter bowl/tray bit, ½" collet extension, ¼" round-over bit, 1" to 1¼" Forstner bit.

Sources

Tray router bit: CMT 1¼"-diameter bit no. 851.502.11B, \$37.68 from Amazon.com. For an alternate, use 1¼"-diameter bit no. 144-2005B, \$40, Eagle America, 800-872-2511 or eagleamerica.com.

Collet extension: CMT ½" collet extension no. 796.001.00, \$33.01 from Amazon.com. For an alternate, use extension no. 415-0660, \$25.88, Eagle America.

MORE RESOURCES

DOWNLOADABLE PLANS

Buy templates and instructions to build a snack tote that complements this tray at woodmagazine.com/snacktote.



From Hobbyist to Industrial Oneida Air Systems is #1 in Dust Collection.

- Top Award Winner in **All** Independent Tests Since 1993.

Some of Our Industry Awards:



-  Invented and Made in the USA.

- Built to Last A Lifetime.

- **FREE** Design Consultation

-  **Oneida HEPA Filters**
GE Certified H12 HEPA Media. Third Party Tested. For the Best Possible Filtration.

- Talk Directly to Our Technical Staff and Engineers

- 1.5hp and Larger Systems

- One Stop Shopping for All of Your Dust Collection Needs.

**The Dust Deputy.
A Cyclone for
Shop Vacuums.**

D.I.Y. Dust Deputy Starts at \$59.00
Deluxe Kit Shown Here \$99.00

Makes the Perfect Gift!

Call Today for **FREE** Catalog!
1.800.732.4065



Oneida
Air Systems

Dust Collection Since 1993.

Order Online!
See Our Complete Product Line & Videos
www.oneida-air.com

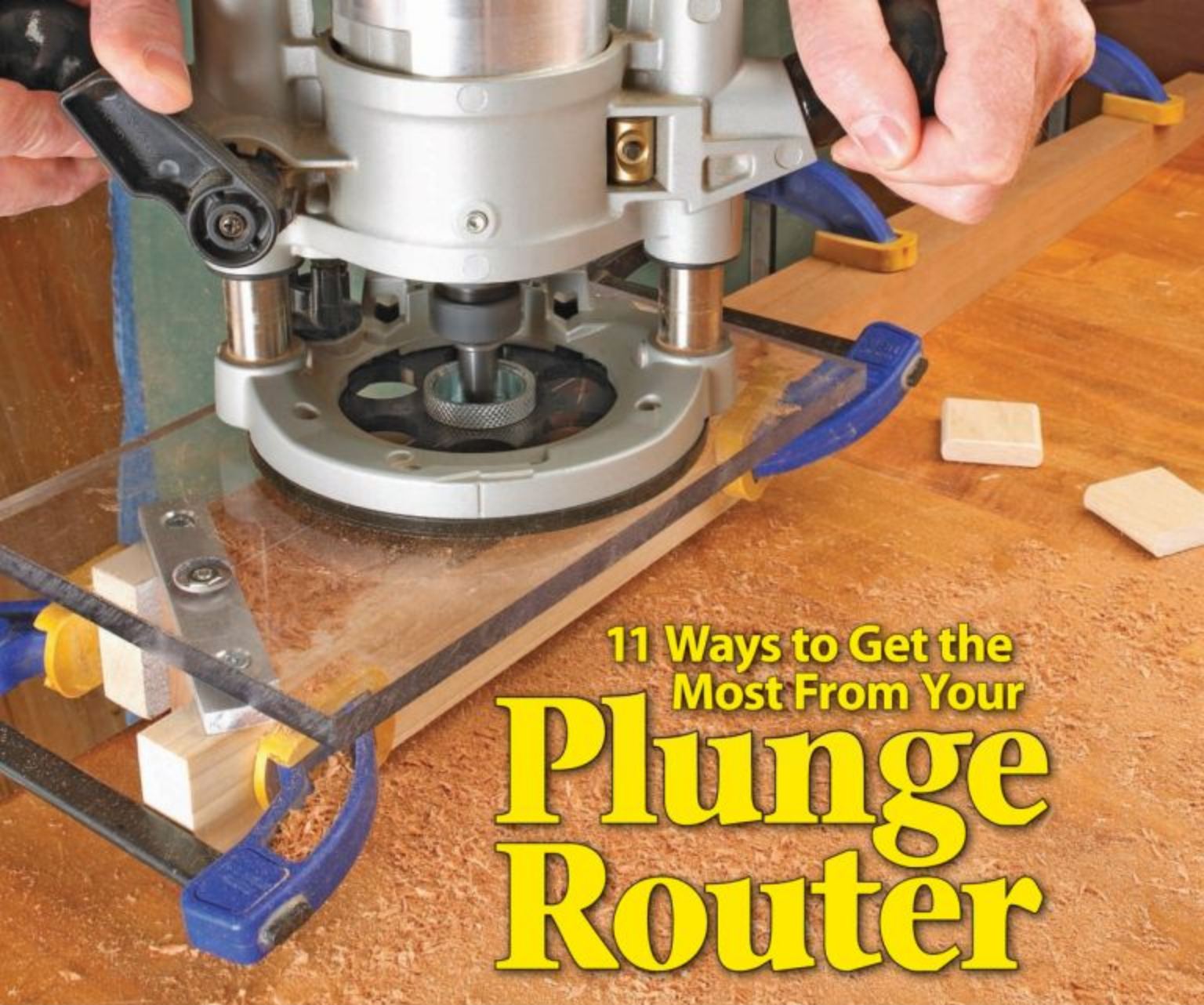

11 Ways to Get the Most From Your Plunge Router

To many woodworkers, a plunge router is like one of those deluxe TV remote controls that has lots of buttons and functions: Most people only use a few of them because they don't understand their full capabilities. Welcome to the plight of the plunge router. Too often this versatile tool gets pushed to the side in favor of its simpler sibling, the fixed-base router. But here are 11 ways a plunge router beats its brother.

1. Mortising

Store-bought or shop-made jigs increase the accuracy of a router as well as its ability to make identical, repeated plunge-router tasks. For example, you don't need to own a hollow-chisel mortiser to make mortises quickly and easily. Simply build the jig shown on the *next page*, grab your plunge router and an upcut spiral bit, and you're in business. Install a $\frac{5}{8}$ " guide bushing in your router's subbase and a bit that matches the width of your mortise. Center the scribed lines on the jig to your mortise layout lines, and then rout in $\frac{1}{4}$ "-deep increments. Depending on the position of your mortises, sometimes only one of the jig's aluminum cross bars will rest on the

workpiece. To keep the jig parallel to the workpiece in these instances, add a $\frac{1}{4}$ " spacer, as shown in **Photo 1**.

For the tenons, you have three options, all of which work equally well. First, you can rout mortises in both of the mating workpieces and make a loose tenon to fit. To do this, dimension stock to the thickness and width you'll need, and then round over the edges on your router table. Second, machine a tenon onto the mating workpiece as you'd do for a rectangular mortise, and then simply round the edges with a knife or rasp. Or third, square the mortise corners with a chisel to fit a matching tenon.

2. Doweling

Make the same jig as for mortising, but rather than slotting the acrylic top, simply bore two $\frac{5}{8}$ " holes, as shown in **Photo 2**. Make multiple tops with different spacing between the holes for different dowel setups. To use this jig, set it up as you would for mortising, and then plunge the holes to your desired depth. Repeat for the mating workpiece, and assemble the joint with glue and dowels.

MORTISING/DOWELING JIG

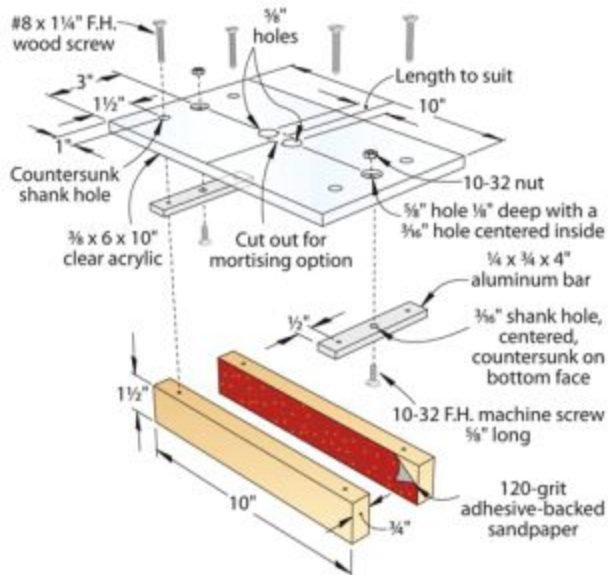

TWO TYPES OF JOINTS WITH THE SAME BASIC JIG



Insert a spacer in the mortising jig where this leg's taper begins. That keeps the jig parallel to the mortised surface.



Because the holes on this doweling jig are near the board's end, use a same-thickness scrap for a spacer.

ANATOMY OF A PLUNGE ROUTER

As the name suggests, a plunge router's bread and butter is its ability to lower a bit onto a workpiece and make any number of cuts, such as stopped dados or mortises, without needing an entry or exit point along an edge or end. Internal springs make it snap straight up after you finish the cut. You control the depth of cut with a stop rod that contacts a multi-position, rotating turret stop. Using multiple stops, you can rout deeply in small increments before getting to the final depth, avoiding grain tear-out and saving wear on the motor and bit.

In addition to handheld use, a plunge router also excels mounted in a router table. Many models now include built-in lift mechanisms, including some that raise the collet high enough for above-the-table bit changing. Dedicated plunge routers, such as the one shown below, do not fit into aftermarket router lifts, but the motors from multibase models (ones that interchange between plunge and fixed bases) fit most lifts and can be easily removed for handheld use in their bases.

Plunge routers range in size from the 1.1-hp Trend T4 (essentially a trim router in a plunge base) to midsize models with 1 1/2 to 2 1/4 hp to monster routers with 3-plus hp. Most midsize and larger routers come with variable-speed motors and 1/4" and 1/2" collets.





3 PLUNGE DEEP FOR FOOD SERVERS

Using a wide auxiliary subbase for stability and bit extension for extra depth, you can rout deep bowls and trays.

3. Interior pattern routing

When you need to rout any type of closed pattern in the interior of a workpiece, such as the chip/dip tray [Photo 3] and on page 50, choose a plunge router. With a fixed-base router you have to tip the router into the cut—risky because you can damage the workpiece or template or possibly injure yourself.

Whether you use commercial templates or make your own, you'll need to use either a guide bushing or a top-bearing pattern bit to register against the template. For cuts deeper than your bit can reach, use a collet extension, which fits into your router collet and has another collet for your bit.

Collet extension: MLCS Woodworking, part #9464 (½" shank), \$25, 800-533-9298, mlcswoodworking.com.

4. Stopped dados, grooves, and flutes

When you need to make field cuts like these, tilting a fixed-base router into the workpiece might cause it to veer off track and damage your workpiece. With a plunge router you simply use a clamp-on straightedge or an edge guide [Photo 4] made by your router's manufacturer. Add stops at each end, and it's almost goof-proof.

5. Circle routing

To create perfect circles, mount your router to a trammel arm that rotates around a fixed point [Photo 5]. With a plunge router you can quickly cut out the workpiece from a larger blank, without need of a saw. Build a trammel arm from our downloadable plan at: woodmagazine.com/routertrammel.

6. Sign-making

You've got two options here. First, you can sketch the lettering onto your workpiece, and then freehand rout along the lines. But that requires a steady hand—one slip-up and you'll have to start over. Or, use a commercial sign-making system [Photo 6] with a guide bushing in the plunge base.

SignPro sign-making kit: MilesCraft, part #1212, \$60, 847-683-9200, milescraft.com.

7. Inlay

As with sign-making, it takes a steady hand to rout inlay recesses freehand. Mess up and you're forced to mend the goof. By using templates with bearing-guided bits or guide bushings, you eliminate the chances of veering off course. And

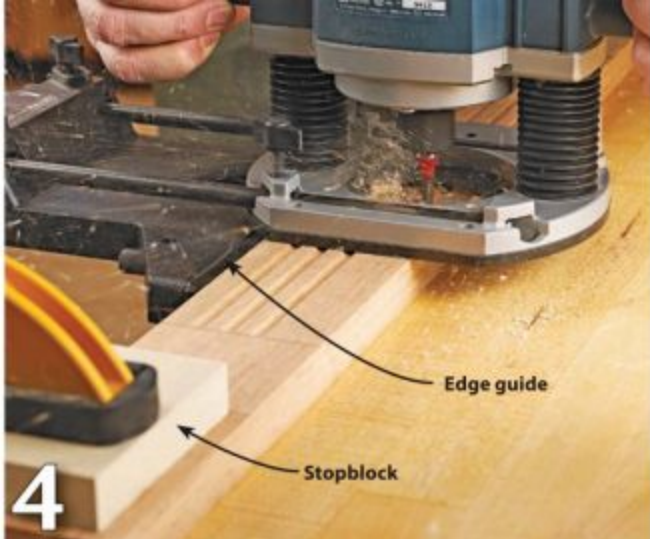

4 CAN'T-MISS STOPPED GROOVES

Make flawless stopped grooves or flutes by using an edge guide to keep them straight and stopblocks for matching ends.



5 HOW TO MAKE A PERFECT CIRCLE

This trammel arm adjusts to rout various-sized, dead-on circles every time. Rout in ¼"-deep increments.

whether the inlay serves for decoration or to patch a flaw in the wood, store-bought kits [Photo 7] provide everything you need to rout the recess as well as exact-fitting inlays.

Inlay products: Eagle America, brass inlay kit, part #400-1321, \$40; butterfly template, part #400-1914; 800-872-2511, eagleamerica.com.

8. Keyholes

Hanging something on a wall but don't want to use a hanger bracket or wire? A slotted keyhole [Photo 8] does the job nicely and won't be seen, because the screw head and shank slip into the slot. Many manufacturers make router bits specifically for making these keyhole slots in several sizes; choose the one that best fits the screws you'll use. You can use one keyhole slot for small projects or two or three for larger ones. It's always best to drive the screws into wall studs, so lay out your keyholes accordingly. Whether you place the keyholes on vertical or horizontal elements of your project, the technique is the same. Plunge into the back to the preset depth, and then rout



6

ROUT SIGNS QUICKLY AND EASILY

With this adjustable jig and two sizes of letter templates you can make block-letter signs in just a few minutes.

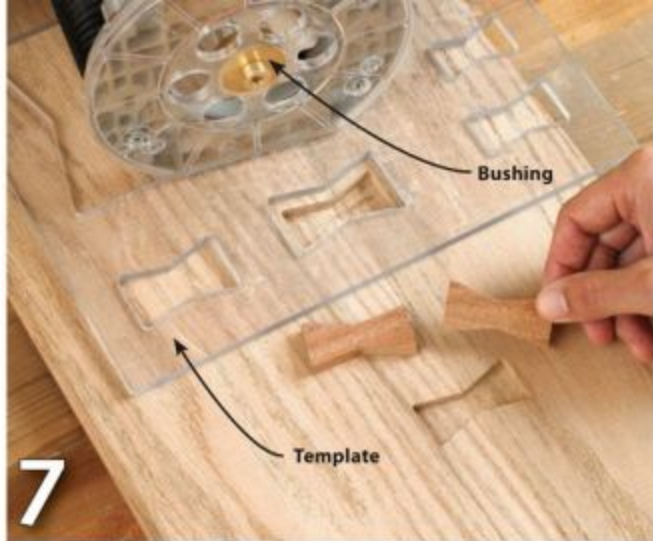

7

TIE IT OFF

Using this jig, bit, and bushing set, we added decorative butterfly bow ties centered along the glue line of this oak panel.



8

JUST FOR HANGING AROUND

Run your router against a straightedge to keep the keyhole slot parallel to the workpiece.



9

"X" REALLY DOES MARK THE SPOT

Plunge when the crossed lasers hit your mark. Apply self-adhesive sandpaper to the bottom of the acrylic subbase so it won't slip.

about an inch or two of slot. Turn off the router and return to the spot where you plunged in before lifting the router.

9. Dual-light offset subbase

Laser locators and LED lights make this subbase from MLCS ideal for many plunge-routing tasks even if you never hold it by its offset knob. The crosshair lasers prove especially useful for lining up a plunge cut, such as the marble holes in the Chinese-checkers board shown [Photo 9]. Flip the switch the other way, and bright LED lights illuminate hard-to-see tasks. On-Point Dual-Light Subbase: MLCS, part #9098, \$60, 800-533-9298, mlcswoodworking.com.

10. Shelf-pin holes

By making the Quick & Easy Jig on page 18, you can use your plunge router to bore any number of perfectly aligned shelf-pin holes.

11. Dust hoods

Some router manufacturers include dust hoods with their routers, but many also come as accessories. Typically made of clear plastic, these prove helpful in gobbling up chips and dust when hooked to a shop vacuum. 🌳

MORE RESOURCES

- **Router techniques:** View more than two dozen FREE router technique articles at woodmagazine.com/routertechniques.
- **Router reviews:** View seven pay-per-download router and accessory reviews at woodmagazine.com/routerreviews.
- **Chinese checkers game board:** Buy the downloadable plan and pattern at woodmagazine.com/chinesecheckers.

Written by **Bob Hunter** with **Kevin Boyle** and **Jeff Mertz**
Illustrations: **Roxanne LeMoine**; **Lorna Johnson**

Jewelry Box

Behind those sinuous curves lies straightforward construction.



Overall dimensions: 14" wide x 8¼" deep x 7⅞" high.



Spend just a few evenings in the shop crafting this box, then let its curves bedazzle its recipient. Joinery for the carcass and drawers requires only a router table with a couple of straight bits; your bandsaw makes easy work of the flowing lines on the front.

Construct the case

1 Glue up a ½"-thick blank for the sides (A) and cut them to size [Materials

List, page 62]. Glue up two 8¾×14" blanks for the top and bottom (B) and edging (C). After the glue has dried, rip a 7"-wide top/bottom from each blank. Save the cutoff for the edging. Mark the top, bottom, and the mating cutoffs so you can reorient them properly after cutting the edging to shape.

2 Using a ¼" straight bit in your router table, rout the dados across the top (B) and bottom (B) [Drawing 1]. Use a

REATTACH THE EDGING



A Align the marks you made on the edging (C) and the top or bottom (B). The matching grain pattern makes the joint line disappear.

GLUE UP THE BOX



B Apply glue to the rabbets in the sides (A) and clamp them to the top and bottom (B), snug against the edging (C).

OUTLINE YOUR WORK



C Trace the shape of the edging (C) onto the front feet (E). Cut away most of the waste on the bandsaw, then sand to the line.

backer board to prevent tear-out as the bit exits the workpiece. Reset the fence flush with the back edge of the bit. Cut the rabbets along the top, bottom, and back inside edges of the sides (A), sneaking up on the final depth until the tongues on each end fit the dados in the top and bottom (B).

3 To rout the stopped rabbet along the back edges of the top and bottom (B) [Drawing 1], clamp stopblocks to the fence $13\frac{1}{2}$ " on either side of the bit. With the right end of the top against the right stopblock, pivot the workpiece into the bit and move it along the fence until reaching the left stopblock. Quickly swing the top's right end away from the bit. Repeat this process on the bottom (B).

4 Switch to a $\frac{3}{8}$ " straight bit and cut the dados across the inside faces of the sides (A) [Drawing 1]. Make sure you end up with mirrored sides.

5 Make four copies of the **Edging, Upper/Lower Drawer Pull Pattern** on pages 60–61 and set two aside for later. Use spray adhesive to attach a copy to each edging (C), aligning the straight back edge of the pattern with the edge that mates with the top/bottom (B). **Note:** Flip the pattern over so the curve is reversed on the top edging [Drawing 1]. At the bandsaw, cut just outside the curved line, then sand up to the line by hand or with a drum sander [More Resources, page 62]. Use mineral spirits to remove the pattern, then glue each edging (C) to its mating top or bottom (B), keeping the faces and ends flush [Photo A].

1 EXPLODED VIEW

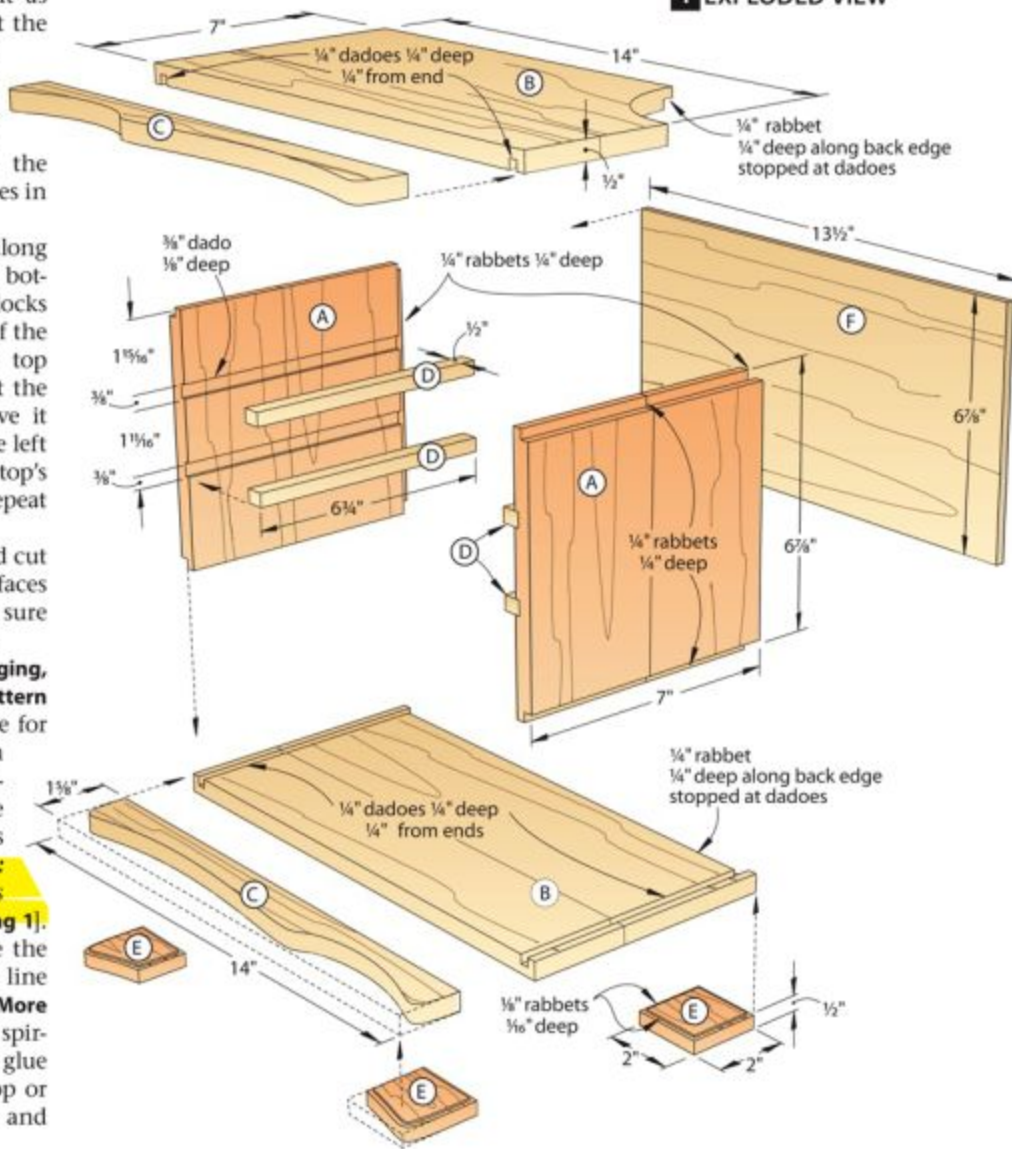

CUT THE FACES TO ROUGH SHAPE



D On the bandsaw, cut just outside the pattern line on each drawer face (L, M, N); then sand up to the line on a drum sander.

MAKE THREE IDENTICAL PROFILES

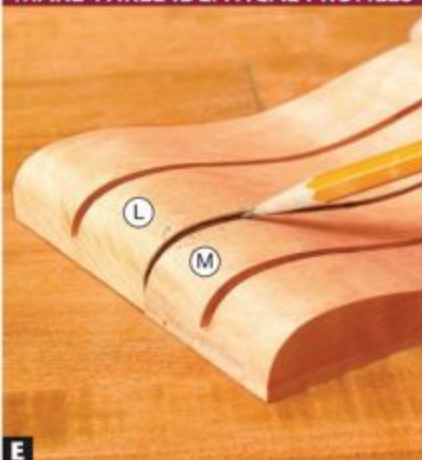

E Compare the three drawer faces (L, M, N); then trace the lowest profile among them onto the other two. Sand to the lines.

6 Mill the drawer runners (D) to fit in the dadoes in the sides (A), then glue and clamp them in place [Drawing 1]. After the glue dries, glue the side assemblies (A/D) and top/bottom (B/C) together [Photo B].

7 Cut four feet (E) and place one under each corner of the case with the front feet flush to the side of the case and pro-

truding $\frac{1}{16}$ " in front. Make sure the grain runs side-to-side, then trace the edging (C) onto the front feet [Photo C]. Cut and sand them to shape, then rout rabbets around all four edges of each foot [Drawing 1]. **Quick Tip! Keep your fingers away from your feet.** Grip the feet in a handscrew or use a push pad to guide them past the router bit.

Sand the feet to 220 grit, then glue them to the bottom of the case flush with the edges, front, and back.

8 Cut the back (F) to fit in the rabbets in the sides (A) and top/bottom (B) and glue it in place.

Make a set of drawers

The two upper drawer boxes are identical; the lower drawer is taller [Drawing 2].

1 Cut the drawer fronts/back (G, I) and sides (H, J) to size. With a $\frac{1}{4}$ " straight bit in your router table, rout the $\frac{1}{8}$ "-deep rabbets on the ends of the drawer sides and along the bottom edges of the sides and fronts/back. Dry-fit the drawer parts and measure for the bottoms (K). Cut the bottoms to size, then glue and clamp the drawers together, making sure that they are flat and square. After the glue dries, check the fit of the drawers in the carcass. Plane or sand the drawers as needed for a smooth-sliding fit.

2 From $\frac{3}{4}$ "-thick stock, cut the drawer faces (L, M, N) to size. **Quick Tip! Go with the (grain) flow.** Cut all three faces from a 7"-wide board to get a continuous grain flow across the

COPY BOTH HALVES OF EACH PATTERN AND REALIGN AT REGISTRATION MARKS TO FORM ONE PATTERN.

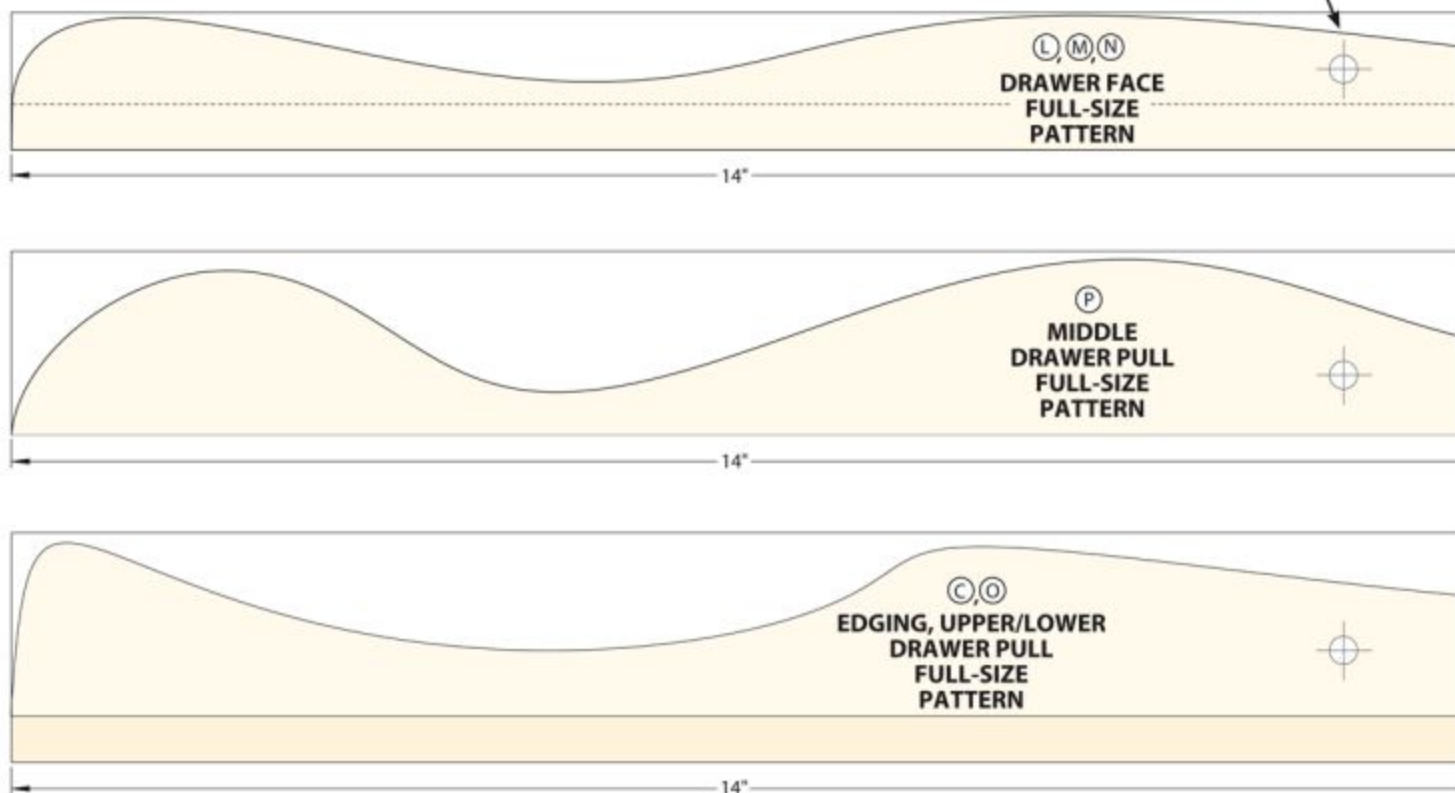

SHOP TIP

Planing thin parts

Workpieces thinner than $\frac{3}{16}$ " may break apart when fed through a planer. To reduce that likelihood, use double-faced tape to fasten each piece to a sled, then run the sled through. Use $\frac{1}{2}$ " or $\frac{3}{4}$ " MDF or melamine for the sled, or plywood if it's flat. Taking light cuts and using your planer's fastest cutter speed and slowest feed rate also helps to reduce chip-out.



faces. Note that the curve of the top pull should match that of the top edging (C), and the curve of the bottom pull should match the bottom edging.

6 Glue the middle and upper drawer faces (M, N) flush with the bottom of the drawer. Glue the bottom drawer face (L) $\frac{1}{16}$ " above the bottom of the drawer to create a gap below the drawer face when it is slid into the case.

7 Sand all parts to 220 grit, then apply a finish. We wiped on a coat of boiled linseed oil followed by three coats of aerosol lacquer, sanding lightly between coats with a 320-grit sanding sponge.

8 After the finish dries, apply self-adhesive felt to the inside of the drawer bottoms (K), and slippery tape to the bottom edge of the bottom drawer sides (H). 🌱

Written by **Craig Ruegsegger** with **Kevin Boyle**
Project design: **Jeff Mertz**

Illustrations: **Roxanne LeMoine; Lorna Johnson**

Cutting Diagram

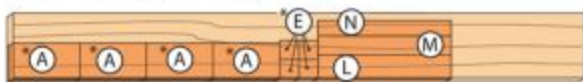

$\frac{3}{4}$ x $7\frac{1}{4}$ x 60" Cherry (3.3 bd. ft.)

*Plane or resaw to the thicknesses listed in the Materials List.

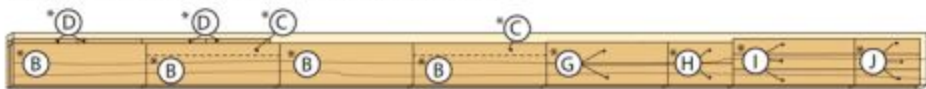

$\frac{3}{4}$ x $5\frac{1}{2}$ x 96" Bird's-eye maple (4 bd. ft.)

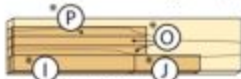

$\frac{3}{4}$ x $5\frac{1}{2}$ x 24" Bird's-eye maple (1 bd. ft.)

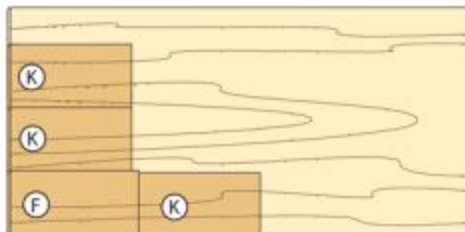

$\frac{1}{4}$ x 24 x 48" Birch plywood

Materials List

Case	FINISHED SIZE			Matl.	Qty.
	T	W	L		
A sides	$\frac{1}{2}$ "	7"	6 $\frac{3}{4}$ "	EC	2
B* top/bottom	$\frac{1}{2}$ "	7"	14"	EM	2
C* edging	$\frac{1}{2}$ "	1 $\frac{1}{2}$ "	14"	EM	2
D drawer runners	$\frac{3}{8}$ "	$\frac{1}{2}$ "	6 $\frac{3}{4}$ "	M	4
E feet	$\frac{1}{2}$ "	2"	2"	C	4
F back	$\frac{1}{4}$ "	6 $\frac{3}{4}$ "	13 $\frac{1}{2}$ "	BP	1

Drawers

G lower front/back	$\frac{1}{4}$ "	2 $\frac{3}{16}$ "	12 $\frac{1}{16}$ "	M	2
H lower sides	$\frac{1}{4}$ "	2 $\frac{3}{16}$ "	6 $\frac{3}{16}$ "	M	2
I upper fronts/back	$\frac{1}{4}$ "	1 $\frac{1}{8}$ "	12 $\frac{1}{16}$ "	M	4
J upper sides	$\frac{1}{4}$ "	1 $\frac{1}{8}$ "	6 $\frac{3}{16}$ "	M	4
K bottoms	$\frac{1}{4}$ "	6 $\frac{3}{16}$ "	12 $\frac{1}{16}$ "	BP	3
L lower face	$\frac{3}{4}$ "	2 $\frac{1}{2}$ "	14"	C	1
M middle face	$\frac{3}{4}$ "	2"	14"	C	1
N upper face	$\frac{3}{4}$ "	1 $\frac{1}{8}$ "	14"	C	1
O upper/lower pulls	$\frac{1}{8}$ "	1"	14"	M	2
P middle pull	$\frac{1}{8}$ "	1"	14"	M	1

*Parts cut from same blank. See the instructions.

Materials key: EC—edge-glued cherry; EM—edge-glued bird's eye maple; C—cherry; BP—birch plywood.

Supplies: Spray adhesive.

Bits: $\frac{1}{4}$ ", $\frac{3}{8}$ " straight router bits.

Sources

Self-adhesive felt: Red self-adhesive felt 17x24" (1) item 76K04.05, \$13.80, Lee Valley, 800-871-8158, leevalley.com.

Slippery tape: 1"x18" (1) item 25U04.01, \$11.50, Lee Valley.

Kit: For a lumber kit for the jewelry box, call Heritage Building Specialties, 800-524-4184, heritagewood.com. Order kit W195.

MORE RESOURCES

FREE VIDEO

Turn your electric drill into a portable drum sander at woodmagazine.com/drillsanding



RELATED ARTICLE

"Portable Drum Sander," issue 185 (September 2008) \$

(\$=download this article for a small fee from woodmagazine.com/plans. Type "drum-sander" in the Search box.)

Bob Vila endorses and recommends the famous EdenPURE® portable heater

Millions of Americans now saving up to 50% on their heating bills and raving about the "heavenly heat"

Does not get hot, cannot start a fire and will not reduce humidity or oxygen

Never be cold again

The famous infrared portable heater, the EdenPURE®, which can cut your heating bills by up to 50%, has been greatly improved.

The new EdenPURE® GEN3 heater heats better, faster, saves more on heating bills and runs almost silent.

The EdenPURE® can pay for itself in a matter of weeks and then start putting a great deal of extra money in your pocket after that.

A major cause of residential fires in the United States is portable heaters. But the EdenPURE® cannot cause a fire. That is because the advanced infrared heating element never gets to a temperature that can ignite anything.

The outside of the EdenPURE® only gets warm to the touch so that it will not burn children or pets.

The EdenPURE® will also keep you healthy. That is because, unlike other heating sources, it will not reduce humidity or oxygen in the room.

The advanced space-age EdenPURE® Infrared Portable Heater also heats the room evenly, wall-to-wall and floor-to-ceiling. And, as you know, most other portable heaters only heat an area a few feet around the heater.

Unlike other heating sources, the EdenPURE® cannot put poisonous carbon monoxide, any type of fumes or any type of harmful radiation into a room.

Q. What is the origin of this amazing heating element in the EdenPURE®?

A. This advanced heating element was discovered accidentally by a man named John Jones.

Q. What advantages does this advanced infrared heating process have over other heating source products?



Cannot start a fire; a child or animal can touch or sit on it without harm

Pictured above is Bob Vila demonstrating the famous EdenPURE® GEN3 Model 1000 heater with a family. It saves big money on your heating bill while keeping you toasty warm with "heavenly heat".

A. This infrared heating process was designed around the three most important consumer benefits: economy, comfort, and safety.

In the EdenPURE® process, electricity is used to generate a type of infrared heat which, in turn, creates a very safe heat.

Q. How can a person cut their heating bill by up to 50% with the EdenPURE®?

A. The EdenPURE® will heat a room in minutes. Therefore, you can turn the heat down in your house to as low as 50 degrees, but the room you are occupying, which has the EdenPURE®, will be warm and comfortable. The EdenPURE® is portable. When you move to another room, it will quickly heat that room also. This can drastically cut heating bills, in some instances, by up to 50%.

End of interview.

The EdenPURE® will pay for itself in weeks. It will keep a great deal of extra money in a users pocket. Because of today's spiraling gas, oil, propane, and other energy costs, the EdenPURE® will provide even greater savings as the time goes by.

The EdenPURE® heater is now greatly improved. With no increase in price, the new EdenPURE® has been updated with the latest technology, safety, and comfort features to provide you with even greater comfort, more savings, and years of reliability. The EdenPURE® comes with a comprehensive three year warranty along with a 60-day no questions asked satisfaction guarantee - we pay the return shipping.

This product has been listed by Underwriters Laboratories.

Testimonials from a few of the millions of satisfied EdenPURE® customers

The EdenPURE® has cut my gas bill to a third of what it was last year. *Leslie Wilson, Vancouver, WA*

The EdenPURE® really puts out the heat like a little solar furnace. It's below freezing outside and cozy warm in the rather over large living room area where I'm using it. I have already noticed a 40 to 60% drop in the cost of my heating bills. *George B., Triangle, N.Y.*

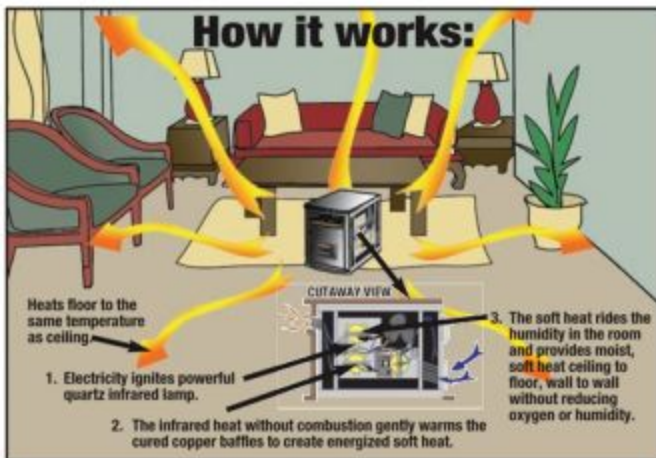

SPECIAL READER'S DISCOUNT COUPON

The price of the EdenPURE® GEN3 Model 500 is \$372 plus \$17 shipping for a total of \$389 delivered. The GEN3 Model 1000 is \$472 plus \$27 shipping and handling for a total of \$499 delivered. People reading this publication get a \$75 discount plus free shipping and handling and pay only \$297 delivered for the GEN3 Model 500 and \$397 delivered for the GEN3 Model 1000 if you order within 10 days. The EdenPURE® GEN3 comes in the decorator color of black with burled wood accent which goes with any decor. There is a strict limit of 3 units at the discount price - no exceptions please.

- Check below which model and number you want:
 GEN3 Model 500, number _____ GEN3 Model 1000, number _____
- To order by phone, call TOLL FREE 1-800-588-5608 Authorization Code EHS1247. Place your order by using your credit card. Operators are on duty Monday - Friday 6am - 3am, Saturday 7am - 12 Midnight and Sunday 7am - 11pm, EST.
 - To order online, visit www.edenpure.com enter Authorization Code: EHS1247
 - To order by mail, by check or credit card, fill out and mail in this coupon. This product carries a 60-day satisfaction guarantee. If you are not totally satisfied return at our expense, and your purchase price will be refunded - no questions asked. There is also a three year warranty.

NAME _____
ADDRESS _____
CITY _____ STATE _____ ZIP CODE _____

- Check below to get discount:
- I am ordering within 10 days of the date of this publication, therefore I get a \$75 discount plus free shipping and handling and my price is only \$297 for GEN3 Model 500 and \$397 for GEN3 Model 1000 delivered.
 - I am ordering past 10 days of the date of this publication, therefore I pay shipping and handling and full price totaling \$389 for GEN3 Model 500 and \$499 for GEN3 Model 1000.

Enclosed is \$ _____ in: Cash Check Money Order
(Make check payable to BioTech Research) or charge my:
 VISA MasterCard Am. Exp./Optima Discover/Novus
Account No. _____ Exp. Date ____/____/____
Signature _____

MAIL TO:
BioTech Research
Authorization Code EHS1247
7800 Whipple Ave. N.W.
Canton, OH 44767

PROJECT HIGHLIGHTS

- Overall dimensions are 22" wide x 5½" deep x 8¾" high.
- Learn how to scrollsaw perfectly fitted parts from two different wood species at the same time.



A little horsing around with your scrollsaw and you'll have these farm friends finished before you can say E-I-E-I-O. Not ba-a-a-d.

Scrollsawn Barnyard Puzzle

This herd of happy animals is a puzzle within a puzzle, where each one can be assembled and repositioned on the slotted base for hours of play.

Animal hows

1 Edge-glue a panel for the barn (A) blank. Then cut blanks for parts B-I and cut the base (J) to size [Materials List, page 65]. Sand the blanks to 180 grit.

2 Download [see More Resources] or photocopy patterns for the barn (A), horse (B), cow (C), goat (D), pig (E), tractor (F), wagon (G), sheep body (H), and sheep legs (I). Apply the patterns to blanks using spray adhesive, noting the grain orientation shown. Using a #2 scrollsaw blade, cut the outlines of parts A-G. For the sheep, attach the leg (I) blank to the underside of the body (H) blank with double-faced tape [Photo A], and cut the legs.

CUT TWO BLANKS AT ONCE



A Adhere a blank for the sheep legs (I) to the body (H), and saw out waste between both pairs of legs. Then saw away waste along the outsides of the legs.

CUT THE LEGS FROM THE BODY



B Saw the curves of the puzzle parts to separate the sheep legs (I) from the body (H). Remove the waste still taped to the body before sawing the rest of the sheep body.

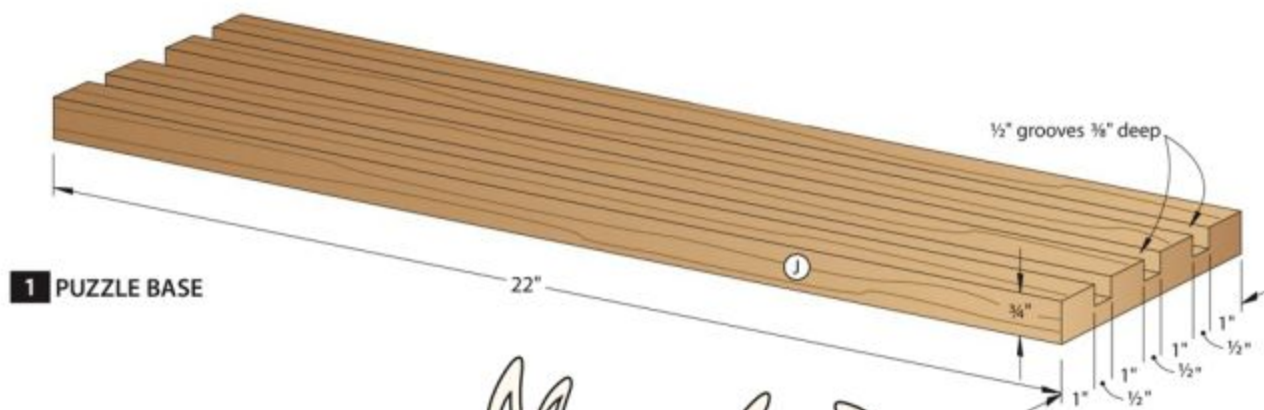

1 PUZZLE BASE

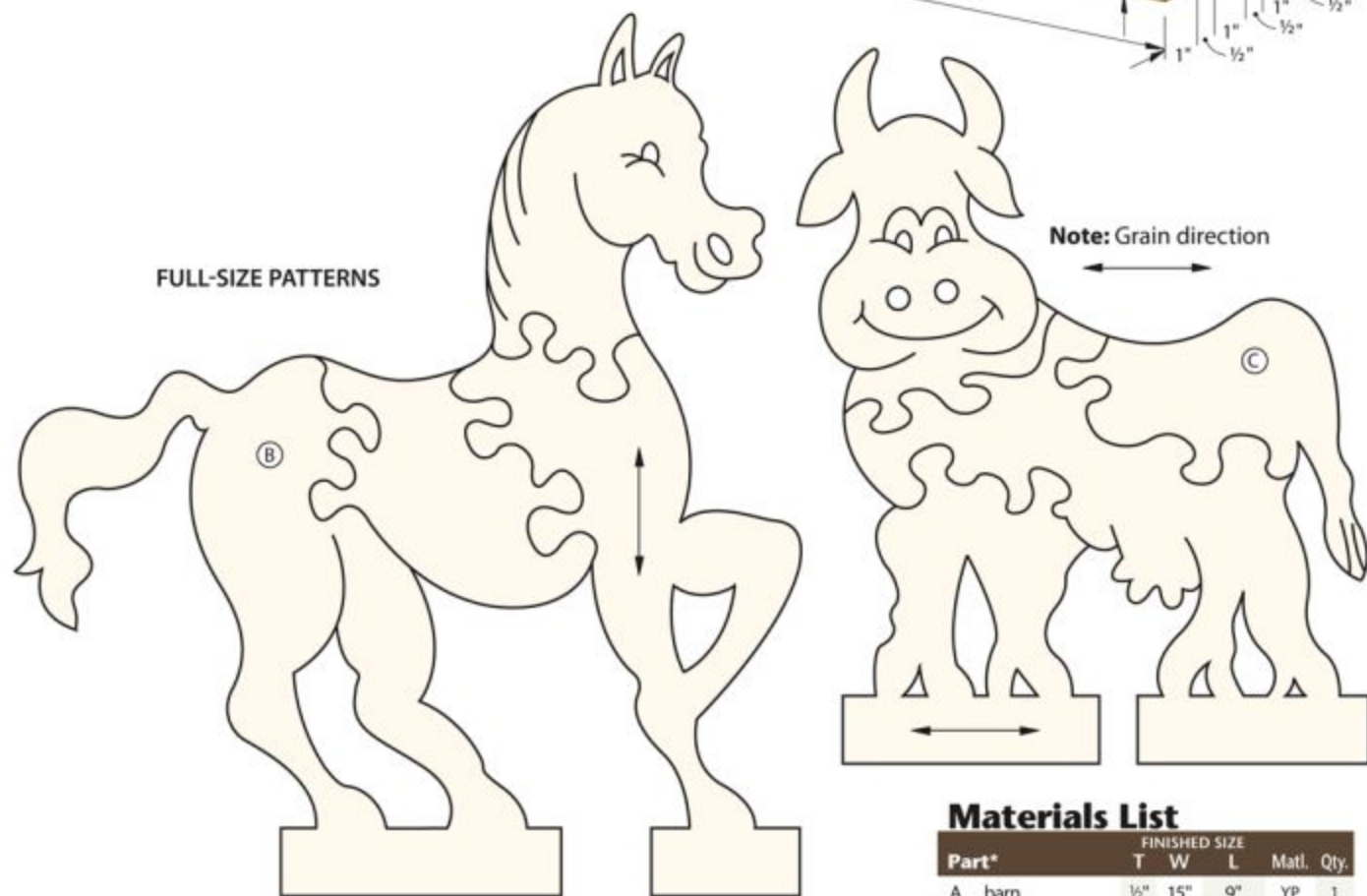

3 Switch to a #2/0 blade for a close fit between the puzzle pieces. Drill and cut the animal faces. Then cut the individual puzzle parts where shown on the patterns [Photo B].

4 Cut $\frac{1}{2}$ " grooves $\frac{3}{8}$ " deep in the base (J) where shown [Drawing 1]. Sand the base to 180 grit, touch-up-sand the figures as needed and apply three coats of clear finish. (We used spray lacquer, sanding between coats with 320-grit sandpaper.)

MORE RESOURCES

DOWNLOADABLE PATTERNS

■ Don't want to cut up this magazine? You'll find free downloadable patterns of all the animals and figures at woodmagazine.com/barnyard.

ADDITIONAL PUZZLE PLANS

■ Go wild with our safari scrollsaw puzzle at woodmagazine.com/safari.
 ■ Reel in a big one—our fish scrollsaw puzzle—at woodmagazine.com/fishy.

While you're there, look at plans for our other games and puzzles.

([\\$](http://woodmagazine.com/plans)—Download this article from woodmagazine.com/plans for a small fee. Type "puzzle" in the Search box.)

Materials List

Part*	FINISHED SIZE			Matl.	Qty.
	T	W	L		
A barn	$\frac{1}{2}$ "	15"	9"	YP	1
B horse	$\frac{1}{2}$ "	5 $\frac{1}{4}$ "	5 $\frac{1}{4}$ "	W	1
C cow	$\frac{1}{2}$ "	4 $\frac{1}{4}$ "	3 $\frac{3}{4}$ "	C	1
D goat	$\frac{1}{2}$ "	4"	3 $\frac{1}{2}$ "	A	1
E pig	$\frac{1}{2}$ "	3 $\frac{1}{2}$ "	3"	L	1
F tractor	$\frac{1}{2}$ "	5"	5 $\frac{1}{2}$ "	R	1
G wagon	$\frac{1}{2}$ "	3"	5 $\frac{1}{4}$ "	R	1
H sheep body	$\frac{1}{2}$ "	3 $\frac{1}{4}$ "	3 $\frac{1}{2}$ "	AS	1
I sheep legs	$\frac{1}{2}$ "	2"	3 $\frac{1}{2}$ "	W	1
J base	$\frac{3}{4}$ "	5 $\frac{1}{2}$ "	22"	C	1

*All part dimensions, except for the base (J), are for blanks to be scrollsawn.

Materials key: YP—yellow pine, W—walnut, C—cherry, A—ash, L—Lyptus, R—redwood, AS—aspens.

Supplies: Double-faced tape.

Blades and bit: $\frac{1}{2}$ " dado set, #2 and #2/0 scrollsaw blades, $\frac{1}{16}$ " drill bit.

Written by **Bob Wilson** with **Kevin Boyle**
 Project design: **Kevin Boyle**
 Illustrations: **Roxanne LeMoine; Lorna Johnson**

FULL-SIZE PATTERNS

COPY BOTH SIDES OF BARN AND REALIGN TO FORM ONE PATTERN.

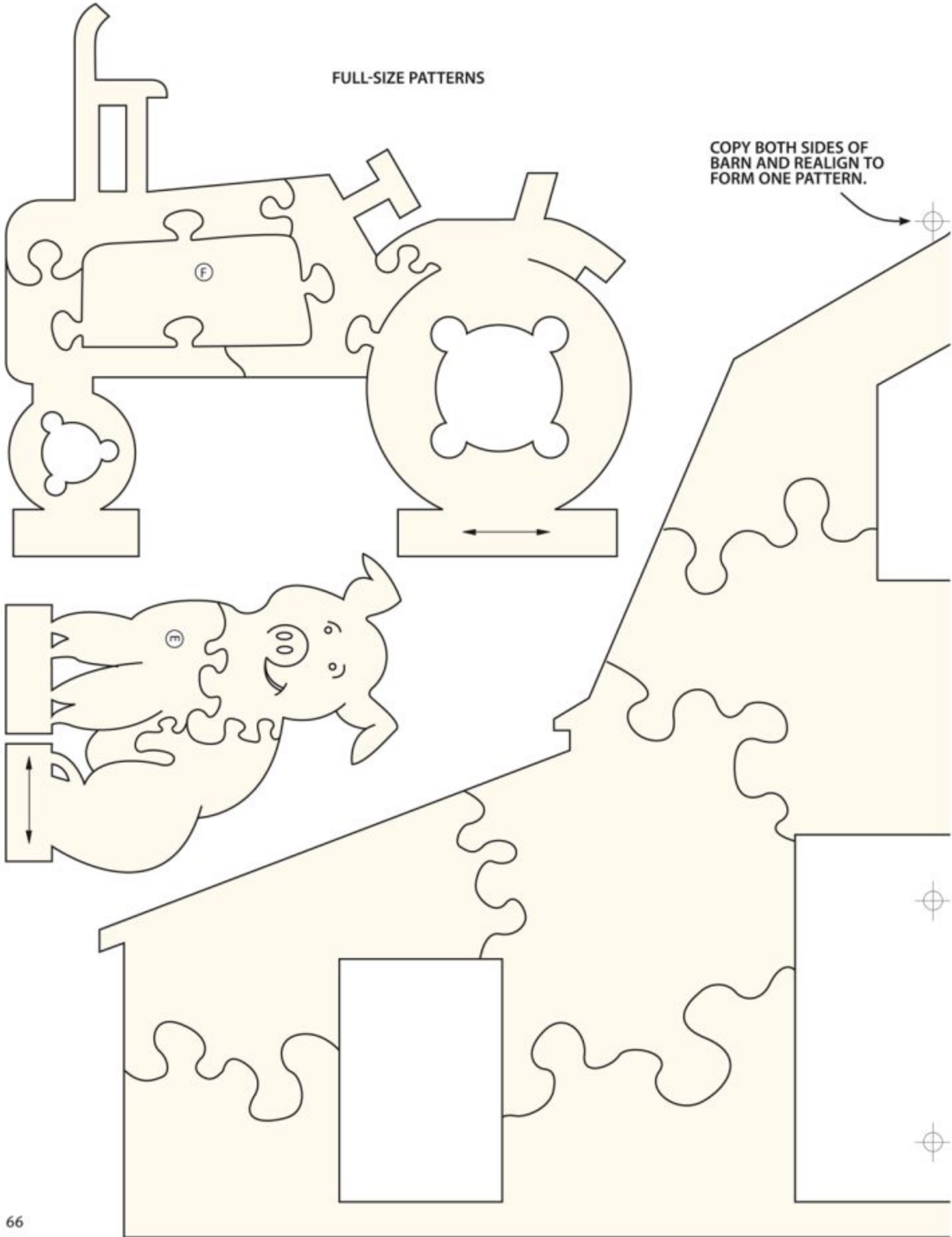

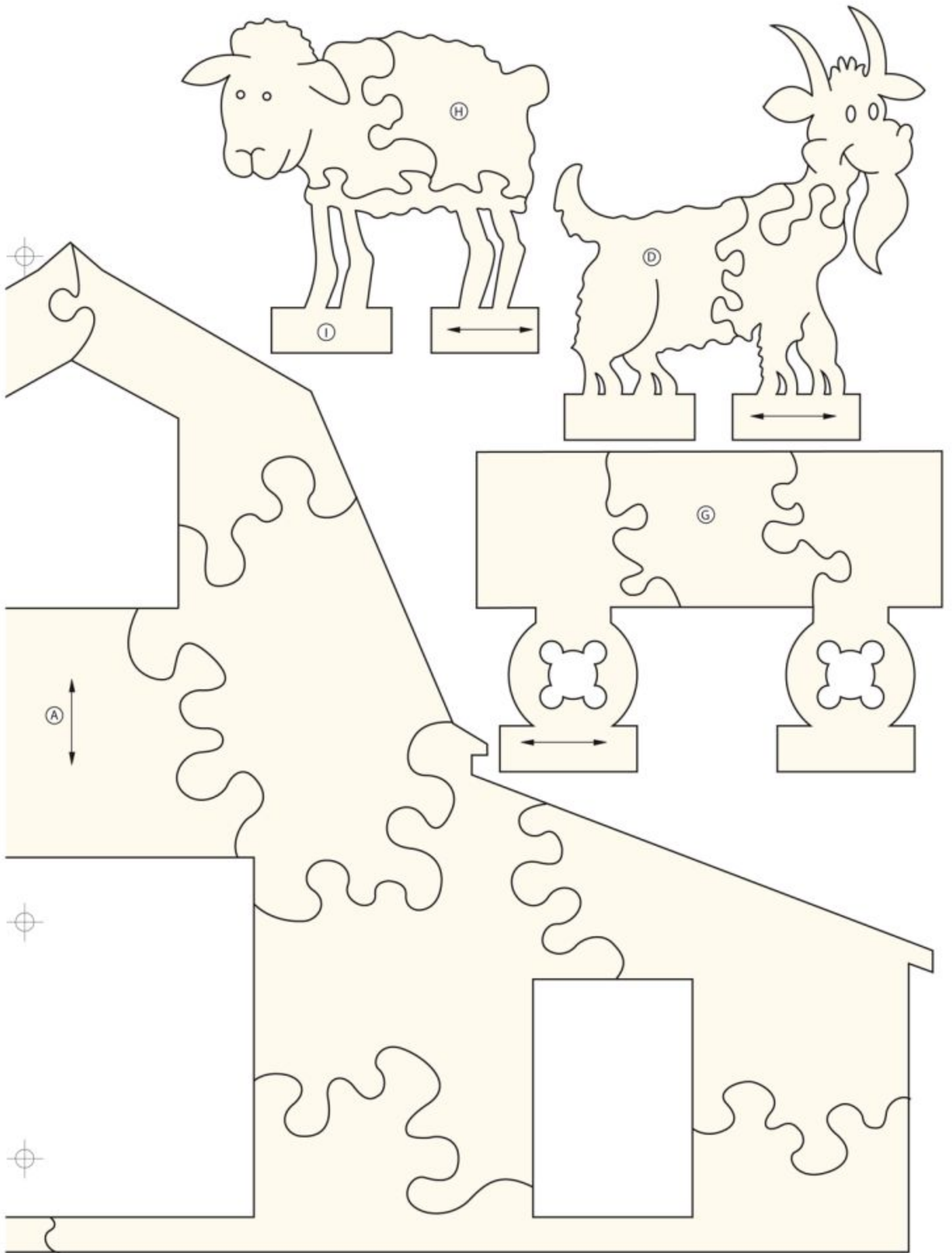

Top New Tools

We select the most promising woodworking tools and accessories for the coming year.



Transfer corner angles to this miter saw's movable fences

Craftsman's 10" MiterMate compound miter saw eliminates the middleman when it comes to cutting trim. Instead of making several test cuts to get the perfect fit for mating trim pieces, you use the included angle finder to duplicate the corner. Next, you transfer that angle to the saw by pivoting the fences—not the blade—to match. Then you simply cut both pieces on their respective sides for an exact fit. Each fence pivots 45° front and back so you can cut inside and outside corners. They also line up straight as on a standard miter saw. The saw bevels up to 45° to the left.

Craftsman
MiterMate MiterSaw, \$250
800-383-4814, craftsman.com

Enjoy cookies with your woodworking

Leave it to the guys in hockey-mad Minnesota to come up with the puck-like Bench Cookies. With a rubbery, textured pad on each face, these pads grip workpiece and workbench equally well, even when routing. And the 1" thickness elevates the workpiece to allow clearance for router-bit bearing screws, as well as access to edges for finishing tasks.

Rockler
Bench Cookies, \$12 per 4-pack
800-279-4441, rockler.com



Route endless cabinet door combos with one bit set

Freud's Premier Adjustable Rail and Stile set gives you the ability to create cope-and-stick doors from $\frac{5}{8}$ " to 1" thick with stub tenons, long tenons, and narrower grooves for undersized flat panels. Add optional cutters and you can rout profiles on both faces, cut glass-panel beads, or increase the door thickness to $1\frac{1}{4}$ ".

Freud
Premier Adjustable Rail and Stile Router Bit Set, \$120
800-334-4107, freudtools.com

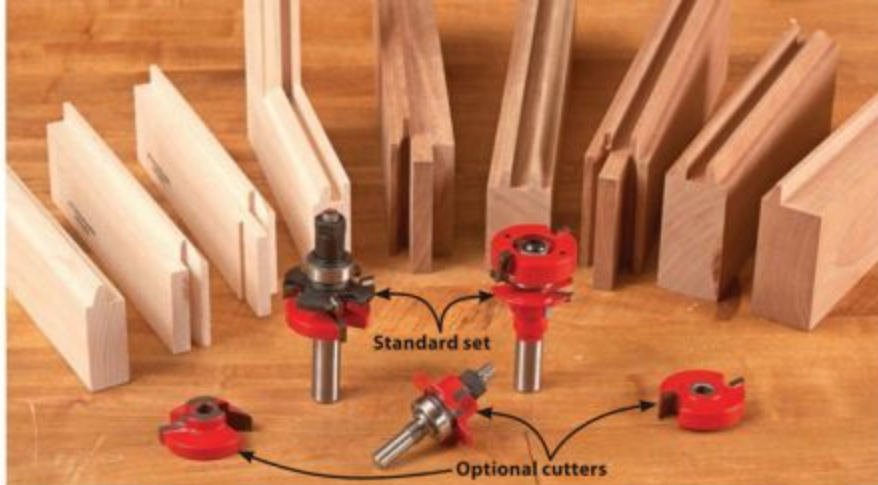

Jazz up cabinet face frames with decorative beaded details

Until now, to make a beaded face frame you had two choices: buy a specialty machine that costs thousands of dollars or mill and mount thin strips with rounded edges to your existing frames. Now Kreg's Precision Beaded Face-Frame System creates integral beads and mitered joints with a simple setup on your router table. (Use your favorite joinery method, such as pocket screws, biscuits, or loose tenons, to assemble the face frame.) The levered fence mechanism mounts in a standard miter slot and features a flip stop for repeatable measurements. With the standard kit you get a notching bit and $\frac{1}{4}$ " bead bit (both with $\frac{1}{2}$ " shanks) and two setup tools. Kreg offers optional bits and setup tools for other bead profiles.

Kreg Tool Company,
Precision Beaded Face-Frame System, \$500
800-447-8638, kregtool.com

Get the Greene & Greene look without the hassle

Ebony plugs with chamfered ends are a hallmark of Greene & Greene furniture. But these decorative details prove time-consuming to make and fit. FastCap's Artisan Accents plugs provide a shortcut: Simply make a partial mortise with a few mallet taps on the included chisel, and then glue in a synthetic-wood plug for an authentic look. FastCap's square plugs measure $\frac{3}{16}$ "; the company plans to offer other sizes in the future.

FastCap
Artisan Accents, \$20 kit, \$5 for 50 plugs
888-443-3748, fastcap.com



Bosch packs user-friendly features into router kit

Not content to simply sit on its award-winning 1617EVSPK two-base router kit—Top Tool in the July 2008 issue of *WOOD*® magazine—Bosch rolls out a premium combo kit as an upgrade. Most significant among the changes: finger-grip, lockable triggers on both bases' handles, an industry first for kits with interchangeable motors. The second major feature makes that possible. The motor and base sport electrical contact strips that, when coupled, channel electrical current from the motor to the switch. This kit also features bit-depth micro-adjustment even with the plunge base locked, LED lights around the spindle that remain on with the motor plugged in, and a ball-joint swiveling power-cord mount on the motor.

Bosch
Two-Base Router Combo Kit, #MRC23EVSK, \$320
877-267-2499, boschtools.com



SawStop stays competitive with mid-tier tablesaw

Nearly a decade after the first SawStop tablesaw hit the market, the company has added a third saw to its lineup to give consumers a wider range of choices. The Professional Cabinet Saw is a lighter-duty version of SawStop's Industrial Cabinet Saw, with a different trunnion assembly and dust-collection shroud around the blade. The Professional features a 3-hp motor, 10" blade, riving knife, 36"- and 52"-rip capacities, finger-release throat inserts (*inset*), blade guard with built-in dust port, and SawStop's patented safety blade brake. This table-saw sells for about \$3,000, midway between its Industrial (\$4,000-plus) and Contractor saw (\$2,000).

SawStop
Professional Cabinet Saw, \$3,000
866-729-7867, sawstop.com



There's nothing like a new, er, old sweetheart

Seeking to recapture its one-time dominance in the hand-plane market, Stanley is launching five new Sweetheart Planes, complete with the heart logo and "SW" insignia found on legendary planes of the early 20th century. Made of heavy ductile cast iron with thicker, more durable steel blades than modern Stanley planes and a one-piece frog and base, these recreations are easier to fine-tune. In this lineup: No. 60½ low-angle block plane (\$100), a No. 9½ block plane (\$100), No. 62 low-angle jack plane (\$180), No. 4 smoothing plane (\$180), and No. 92 shoulder plane (\$180). Additional models will follow.

Stanley Tools
Sweetheart Hand Planes, \$100-180
800-262-2161, stanleytools.com



3-speed impacter drives with greater precision

Impact drivers deliver greater torque than standard cordless drill/drivers, but not a lot of control over that power. Makita's lightweight, 18-volt, lithium-ion impact driver (model LTD144) features a category-leading 1,420 inch-lbs of torque, and also has a three-speed transmission. Set it in the low range for small screws that might twist off easily; go to the middle range for common woodworking screws; or switch into high range for demanding fasteners, such as lag screws. And with the variable-speed trigger you can still fine-tune the bit speed within each range.

Makita
18-Volt 3-Speed Impact Driver, \$350
800-462-5482, makitatools.com



Make mortises and tenons for half the price

We appreciate Leigh Industries' FMT Frame Mortise & Tenon Jig for its ease of routing perfectly matching mortises and tenons. But its \$900 price tag puts it out of reach for most home woodworkers. Now, Leigh's Super FMT does much of what its sibling can, but for half the price. The Super FMT is made of steel rather than aluminum and uses F-style clamps instead of built-in cam clamps. It comes with five ⅜" joint guides for making two dozen sizes of mortise and tenon joints. Leigh sells more snap-in guides as accessories. 🌲

Leigh Industries
Super FMT Frame Mortise & Tenon Jig, \$450
800-663-8932, leighjigs.com



4-WAY MONEY MAKER

MOLDS • PLANES • SANDS • SAWS



Now, turn a \$5.00 rough board into \$75.00 worth of high-dollar molding in just minutes. Make over 500 standard patterns, curved molding, tongue & groove, picture frame stock, any custom design. QUICKLY CONVERTS from Molder/Planer to Drum Sander or powerfeed Multi-Blade Ripsaw. Made in U.S.A. 5-Year Warranty. Choose from 12", 18" or 25" models.

NEW! SHAPE 3 SIDES IN 1 PASS!

NEW 3-Side Molding System turns your Woodmaster into a POWERFUL 3-SIDE MOLDER that efficiently & AFFORDABLY cuts T&G flooring, paneling, & more!

NEW!
3-Side Molding System

- Shape 3 sides per pass!
- Over 500+ Molding Patterns!
- RISK FREE 30-Day Trial Offer!
- Highest Profit: MAKE CURVED MOLDING!



Own a 4-in-1 MOLDING FACTORY!



Quick-Change Molding Head



Unconventional-Duty Table-Top Planer



Power-Feed Drum Sander



Gang Rip Saw Attachment

Get Your FREE DVD & BUSINESS STARTER KIT!
CALL TOLL FREE 1-800-821-6651

Woodmaster Tools, Inc. Dept. P347, 1431 N. Topping Ave., Kansas City, MO 64120 www.woodmastertools.com



Peachtree Woodworking Supply Inc.™

"Your One Stop Supply Shop"®

TIS' THE TO
SEASON SAVE



ptreeusa.com

Over 5000 woodworking items! Shop online 24 hours a day.

Clamps, Sawblades, Router Bits, Abrasives, Books, Videos and More.
Find the brand names you're looking for and More!



f Freud

IRWIN
QUICK-GRIP

NORTON

Fireboard III

Irce

MIRKA

WOODSTOCK

OLSON

OLSON

Peachtree
Woodworking

Ask WOOD

Answers to your questions from letters, e-mails, and WOOD Online

HAVE A QUESTION?

For an answer to your woodworking question, write to **ASK WOOD**, 1716 Locust St., L5-221, Des Moines, IA 50309-3023 or e-mail us at askwood@woodmagazine.com. For immediate feedback from your fellow woodworkers, post your questions on one of our woodworking forums at woodmagazine.com/forums.

Merit badge for a beginner

Q: I'm an absolute beginning woodworker. I bought a tablesaw because I heard that should be my first tool, but I don't know a rabbit from a box joint. Could you suggest some beginner resources?

—Jonathan Akers, Portland, Ore.

A: Welcome to woodworking, Jonathan. If you're just taking the first steps into this best of all crafts, check out the *Woodwork* merit badge booklet issued by the Boy Scouts of America (\$4.50, scoutstuff.org; search for "woodwork"). It's a good starting point that launches you into woodworking inexpensively.

The booklet starts with first aid before moving into the characteristics of trees and lumber, then basic hand tool use. The straightforward projects are designed to bolster your confidence in your tools and build your skillset incrementally.

Before you start up that tablesaw, learn to use it safely. Become thoroughly acquainted with the manual, and then take a look at the safety tips over at woodmagazine.com/tssafety.

Next, take a look at *WOOD*'s Basic Built information (woodmagazine.com/basicbuilt), our initiative to provide high-quality woodworking projects that require a minimum of tools and skills. (We include a Basic Built project in each issue of the magazine.)

Finally, for the inevitable questions and stumbling blocks, head over to woodmagazine.com/forums where you'll find a friendly and knowledgeable community of woodworkers and forum hosts ready to answer your questions.

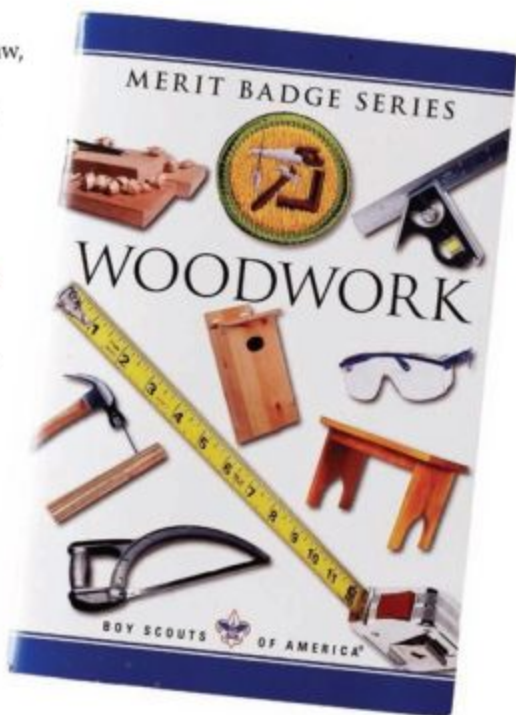

String stabilizes spindles

Q: As the long spindle I was turning became narrower, it began vibrating with a whipping motion. How do I eliminate the vibration?

—Roger Hastings, Escondido, Calif.

A: If sections of your spindle are still rough, Roger, first turn the entire spindle down to a cylinder. This ensures that the stock is centered and balanced on the lathe. Slow the turning speed down and keep your tools sharp to dampen any chatter.

If you find that the spindle still gets whippy, consider using one or more commercially-available spindle steady rests for added support on the spindle's narrower sections. For a low-cost solution, make your own simple steady-rest, like the one shown at right.

Begin by laying out the shape on plywood, centering the rest's opening on your lathe's chuck. Mark the positions of the four screws such that an X drawn between them crosses at the center point. Then, bandsaw the frame to shape and drive the screws. Screw a small office binder clip to the lower left of the rest's base. Next, attach a block of wood with a bolt and wingnut to clamp the rest to the ways of the lathe bed.

Tie a sturdy string to the bottom left screw. Then, with the spindle chucked in the lathe and centered in the rest, wrap the string around the screws in this sequence to capture the spindle: top right, bottom left, bottom right, top left, and

bottom right. Finally, clip the end of the string into the binder clip to hold it tight. Make as many string steadies as you need to support the narrow sections of the spindle.

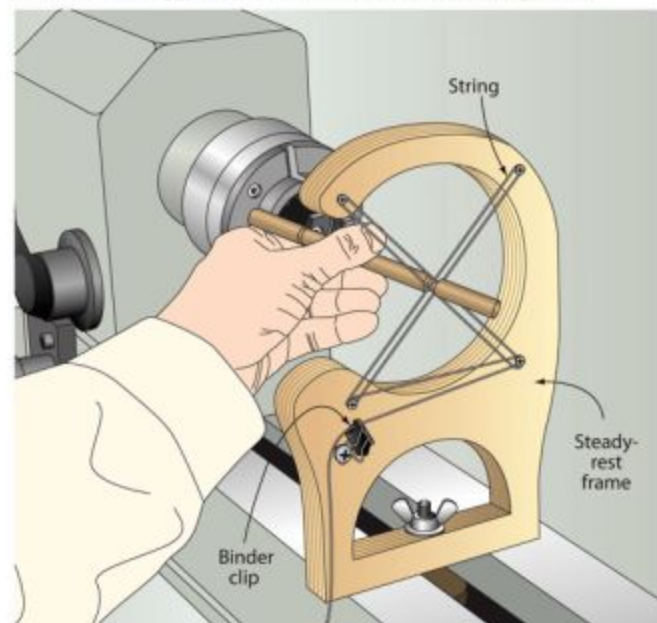

continued on page 74

The NEW **EAGLE** AMERICA WD 1001
 Since 1988

The World's Router Bit Source!

Over **2,000** Router Bits and Sets

Over **5,000** woodworking items!

Request your FREE color catalog

EagleAmerica.com
 1-800-872-2511

DEWALT **Irreg** froud PORTER-CABLE
 FESTOOL Jorgensen Inca

Special Offer **FREE Shipping**
 on your internet order of \$75, prior orders excluded
 - now through 2/28/10 -

To redeem visit: www.EagleAmerica.com/WD1001



GUIDE KITS | STABILIZERS | BLADES | TIRES | AND MORE

"CARTER GUIDES MADE MY BANDSAW FUN AGAIN!"

INCREASE CUTTING SPEED & ACCURACY.

FREE!
 "Bandsaw Tuning" DVD with purchase of Guide Kit or Stabilizer."

Carter products
 BANDSAW UPGRADES

See Carter Products at The Woodworking Shows in 23 cities. thewoodworkingshows.com

carterproducts.com/bandsawfun | 888.622.7837

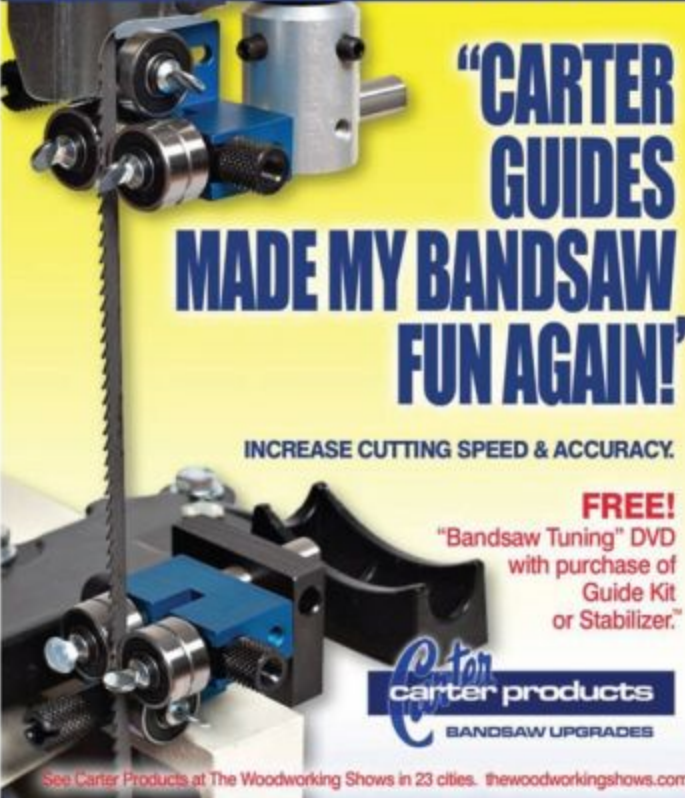

OSBORNE Wood Products, Inc.

*Elegance
 Quality
 Impeccable Designs*

866.849.8876
WWW.OSBORNEWOOD.COM



Forrest Blades

For building cabinets and fine furniture, nothing beats Forrest saw blades.

Craftsmen appreciate the way our blades deliver smooth, quiet cuts without splintering, scratching, or tearouts. They know our unique grade C-4 micrograin carbide, proprietary manufacturing process, and hand straightening produce exceptional results. In fact, independent tests rate us #1 for rip cuts and crosscuts.

"From the first cut on, I realized that this blade was a bargain at any price! Nothing else I have cuts comparably." Calvin Brodie, Spanaway, WA

Forrest Quality Shows

Woodworker II—Best rated, all-purpose blade for rips and crosscuts.

Chop Master—Perfect for tight, perfectly cut miter joints without splinters.

Duraline Hi-AT Woodshop News

Dado King Wood Magazine

FORREST
 The First Choice of Serious Woodworkers Since 1946

www.ForrestBlades.com
 1-800-733-7111
 (In NJ, call 973-473-5236)

Order from any Forrest dealer or retailer, online, or by calling directly. Our blades are manufactured in the U.S.A. and backed by our 30-day, money-back guarantee.

© 2009 Forrest Manufacturing Code WM







Raise your drooping wings

Q: The cast iron wings on my tablesaw droop approximately 1/16" to 1/8" at their ends. How do I correct this?

—Donald Zarate, Las Vegas, Nev.

A: Your first step, Donald, should be to remove the wings completely. With a fine file or 220-grit sandpaper, sand the mating edges of the wings to remove any sharp edges, burrs, or paint. Then, reattach the wings without tightening the bolts all the way; allowing the wings to sag a small amount.

Lay a 4' level across the front edge of one wing and the tablesaw, and clamp it to the outer edge of the sagging wing. As you tighten the front bolt, keep an eye on the bottom of the level. Ideally, when the bolt is tight, the bottom of the level should sit flush across the tablesaw and the wing.

If there is still a gap, the bottom edge between tablesaw and wing needs shimming. Cut strips of brass shim stock (or use cut-up beverage cans).



Loosen the bolt, slide in a shim, and retighten. If the gap doesn't close completely, repeat the process, adding a shim each time, until the tables are flush. Lastly, repeat the leveling process at the center and rear of the wing.

Cut out cupping

Q: I would like to make a box with a top that's 13" wide using a 14"-wide mahogany board. Will there be a problem using a single board for the top?

—Jim Curtis, Longboat Key, Fla.

A: A board that wide will most likely cup unless the grain is riftsawn or preferably quartersawn, Jim. Imagine the end grain's growth rings as curved bands under tension to straighten out. The wider the board and the more the grain runs parallel to the surface, the more likely that tension will be released with time or after you joint and plane the pieces. For a panel as wide as your box top, we prefer to glue-up boards no wider than 5" and preferably 4". If there's a riftsawn or quartersawn grain section at the edges of your 14" boards, cut away the flatsawn cathedral-grain section and edge-glue the straight-grained pieces.



Riftsawn grain Flatsawn cathedral grain Riftsawn grain

continued on page 76

The most popular pinners, voted best

Fine Woodworking Molding Trimming Finishing Intricate Assembly

GreX P6 Series
23 Ga. Headless Pinners

GREX introduced the first pinners with an "adjust-free" magazine design - the defining feature of their line of pinners capable of driving pins from 3/8" up to 2". These are feature-packed industrial tools for those serious about their work.



- | | | | |
|-------------|----------------|----------------|-----------------|
| P650 | P645 | P635 | P630 |
| upto
2" | upto
1-3/4" | upto
1-3/8" | upto
1-3/16" |



Changing ideas into solutions.

Alhambra, CA • 888-4GREXCO • info@grexusa.com
Cheltenham, ON • 905-838-4887 • info@grexcanada.com
www.grexusa.com



FREE SHIPPING**

16 PIECE SET

Bore clean, deep holes in soft or hard wood with virtually no effort!

COMMERCIAL QUALITY

For running electrical wires through floor joists, assembling 2x4 wood playsets for the kids & other tasks, these auger bits make the job a snap! Put some excitement into your next "boring" job with this tradesman's quality 16-pc. set. Each bit is forged from #45 carbon steel & has a heat-treated HRC47 hardness tip, flutes ground behind the lands to pull chips up for fast, clean cutting & a polished finish. Includes 3/8", 1/2", 5/8", 3/4", 7/8" & 1" bits in both 4-3/4" & 8" lengths & 1/2", 5/8" & 3/4" bits in 16" length. Bits come in protective case. Compare At: \$154.99

YOUR PRICE \$29.99 **SPECIAL \$29.99** **FREE SHIP \$2.50**

Every drill bit you will ever need — built to last a lifetime!

115-Pc. Set



EXTRA TITANIUM LIMITED QUANTITIES **LOWEST PRICE EVER!** **EASTERN STEEL**

115 pc. set includes bits ranging from 1/16" to 1/2" by 64ths, numbered sizes from 1-50 and lettered sizes A to Z. Each bit is coated with titanium to last up to six times longer than standard bits!

Titanium Coated! **WAS: \$70.00** **\$29.99** **SHIP \$2.50**

Item No. UB65-56389

Chop, slice, stab and slash with ferocity you won't get from other knives! Others charge hundreds more for quality like this!



ONLY \$29.99 **SHIP \$2.50 FREE**

Item No. UB65-42511 *Adult sig. req. Add'l. ship \$2.00.

Please consult federal, state & local laws before placing an order. Adult signature required on shipping receipt.

CA RESIDENTS WARNING: The products offered for sale in this ad may contain chemicals, including lead, known to the state of California to cause cancer & birth defects or other reproductive harm.

HEARTLAND AMERICA

VISA **MasterCard** **AMERICAN EXPRESS** **DISCOVER**

The Best Values Direct to you from the Heartland!

You'd pay hundreds more if you purchased these router bits separately!

A dream buy for wood workers... 35 high-quality router bits for just \$1.14 each! This incredible set has a huge assortment of bits that let you V-groove, flush trim, chamfer, dovetail and much more with professional results every time. Bits have 1/4" shank and are solid carbide or carbide tipped for years of dependable use and clean cuts with a working error of less than 0.2 mm. Bits come in a wooden storage case with labels to keep them clean and organized. Compare At: \$310.09



YOUR PRICE \$39.99 **FREE SHIP \$2.50**

Item No. UB65-56652

EXTRA TITANIUM LIMITED QUANTITIES

Great Gift Idea!

BIGGER & BETTER

35 PIECE SET



CONTRACTOR'S CHOICE

THE CHOICE OF CONTRACTORS AND TRADESMEN

IMPROVED MODEL

21.6V CORDLESS POWER

Tornado Tools™ 21.6V cordless drill — more features, more power & still the choice of contractors & tradesmen nationwide!

Now is the time to replace your under-powered drill with this contractor-grade drill! It has a high-torque 21.6V motor that drills into wood, metal & masonry with astounding speed & ease. Plus, it has a variable speed up to 650 RPM & 16+ screwdriver settings. And thanks to a 3/8" Jacobs keyless chuck, you can change bits in seconds - no key to fumble with or lose! Drill has on-board bit holder & comes with 15-pc. accessory set including: 6 drill bits, 2" extension bar, 2 double-ended screwdriver bits, 4 Phillips screwdriver bits & 2 straight screwdriver bits. Molded carrying case & AC adapter/charger incl. Extra batteries & charger available, ask operator for details.

Price reflects \$10.00 mail-in rebate. Price before rebate is \$49.99. Rebate expires 1/31/10. Compare At: \$249.95

YOUR PRICE \$39.99 **FREE SHIP \$2.50**

Item No. UB65-56384

Don't get left in the dark...put 2800 watts of reliable power at your fingertips!

When the power goes out or you're camping miles away from the nearest outlet, this generator delivers all the power you need to run lights, power tools, electric appliances & more. Features a 6-1/2" HP overhead valve air-cooled four-stroke engine that pumps out 2800W peak (2600W continuous) of portable power, two 120V AC outlets, 12V DC outlet, circuit breakers on all outlets, automatic voltage regulator, voltmeter & 4 gallon fuel tank for up to 7.8 hours of continuous operation. Also has a hushed design for reduced noise. EPA certified. 23" x 17" x 17.5". Not available in CA. Outdoor use only (see manual). Compare At: \$525.00

Price reflects \$20.00 mail-in rebate. Price before rebate is \$249.99. Offer expires 1/31/10. **WAS: \$249.99** **\$229.99** **SHIP \$2.50**

Item No. UB65-50558



Power on demand for:

- Blackouts
- Power problems
- Storm outages
- Camping
- Work sites
- Natural disasters
- More!

LOWEST PRICE EVER! **AC/DC Dual Power Output**

PUBLIC NOTICE: Natural disasters and power problems strike with little or no notice. So plan ahead and don't get caught in the dark this year. Our limited allocations of generators will sell out quickly, so reserve yours today to avoid disappointment!

HEARTLAND AMERICA

National Headquarters: 3655 Century Blvd, Omaha, NE 68130

Remember to use the code **UB65UB65**

Expires 1/31/10

This coupon cannot be redeemed for cash. One coupon per customer. Some limitations may apply.

\$10 OFF ANY ORDER

PLUS FREE SHIPPING**

Some limitations may apply. See your operator for details. **Someweight items have substantially reduced shipping.

1-800-229-2901
www.heartlandamerica.com

RADIANT

Floor Company

Green Technology
at Your Feet

1.866.WARM-TOES

Our radiant floor heating systems are
compatible with any fuel source:

GAS PROPANE SOLAR OIL WOOD ELECTRIC GEOTHERMAL

VISIT OUR WEBSITE
CALL FOR A FREE QUOTE
www.radiantcompany.com
Barton, Vermont

Ask WOOD

A sticky solution for securing patterns

Q: I'm a beginning woodworker with a basic question: For making templates out of medium-density fiberboard (MDF), what's the best way to secure paper patterns to MDF—double-faced tape, glue, or something else?

—Erick Olsen, Methuen, Mass.

A: Stick to spray adhesives (such as 3M Spray Mount) for securing paper patterns to wood, Erick. Spray the paper with adhesive. Take care to avoid overspray on your workbench, or consider a dedicated spraying surface, such as the one below from issue 111, page 20 (plans available for free at woodmagazine.com/adhesivedrawer).

For the strongest bond, place the paper on the MDF blank right away. If you'd like to remove the pattern later, wait about a minute for the adhesive to become tacky before pressing the pattern to the wood. Once you've cut your MDF template, simply peel the pattern away. If you have trouble removing the pattern, brush on paint thinner. The solvent will soak through the paper and soften the adhesive, making the pattern easier to remove. 🌲



WOOD Magazine's WOODWORKING SHOWDOWN

ONLINE PROJECT CONTEST

Hundreds of woodworkers have uploaded their project photos to this contest—now it is up to you! Cast your votes and determine the winners. There are six categories and over \$6,700 in prizes at stake!

Two months of voting begins Dec. 1, 2009.

You can still upload your project photos by Nov. 30 to be eligible to win!

To learn more about the Woodworking Showdown, cast your votes, and find great project ideas, visit:

www.woodmagazine.com/showdown

Sponsored by:



BEST FURNITURE PIECE



BEST SMALL PROJECT



BEST SHOP PROJECT



BEST SHOP



BEST OUTDOOR PROJECT



BEST HOME IMPROVEMENT PROJECT

CAST YOUR VOTES!
Everyone can vote
daily to determine
the winners.

Bonus Offer
\$50 Savings Card

The Bed Clinically Proven to Reduce Back Pain



FIRMNESS ADJUSTS ON EACH SIDE

YOU CUSTOMIZE THE FIRMNESS

The Sleep Number Bed by Select Comfort™ is unlike any other. It's the bed you adjust to your exact comfort and firmness preference, your SLEEP NUMBER® setting. Our easy-to-use handheld remote and advanced air-chamber technology allow you to quickly adjust the firmness on your side of the bed. **At the simple touch of a button, YOU can change the firmness** from extra firm to feather soft.

CLINICALLY PROVEN

It's the bed clinically proven to relieve back pain and improve sleep quality.*



sleep  number.
by SELECT COMFORT

EACH SIDE OF THE BED ADJUSTS INDEPENDENTLY

On a Sleep Number® bed, each of you can adjust the comfort and firmness to your exact preference—your Sleep Number® setting. Once you find your Sleep Number® setting, you can fall asleep faster, enjoy more deep sleep and wake up more refreshed.



GREAT VALUE

The Sleep Number® bed costs about the same as an innerspring mattress, yet it lasts twice as long.

Receive a Special Thank You Gift!



For a limited time, inquire about our revolutionary bed and we'll send you a special **\$50 Savings Card** to use toward the purchase of any Sleep Number® bed or accessory item of \$100 or more.†

Call Now! **1-800-831-1211** ext. 38533
sleepnumber50.com



YES! Please send me a FREE Brochure, DVD and Pricing.



Limited-Time Bonus!
\$50 Thank You Savings Card!

Name _____
Address _____
City _____ State _____ Zip _____
Phone _____

sleep  number.
by SELECT COMFORT

Mail to: Select Comfort Direct, 9800 59th Avenue North, Minneapolis, MN 55442-9971

*For a summary of independent clinical studies and their results, call 1-800-831-1211.

†Restrictions apply. See savings card for details and expiration date.

Shop-Proven Products

These woodworking wares passed our shop trials

About our product tests

We test hundreds of tools and accessories, but only those that earn at least three stars for performance make the final cut and appear in this section. Prices are current at the time of article production and do not include shipping, where applicable.

Make quick, clean mortises using your handheld drill

With JessEm's Zip Slot Mortise Mill, you simply install the special drill bit—a hybrid of a twist bit and a spiral router bit—in your drill, clamp your workpiece to the jig, and press the spinning bit down as you slide the carriage back and forth. Repeat on the mating piece and insert a loose tenon, or machine a tenon onto that piece.

I drilled mortises up to 3½" wide and 1½" deep in hardwoods and softwoods, end grain and edge grain, making every type of mortise-and-tenon joint I could think of, and always arrived at a perfect fit. Steep flutes on the bit clear chips quickly to avoid overheating and dulling the bit. Etched markings and dead-on scales on the mill and a depth-stop bit collar work so well the system's nearly foolproof.

The model 8100 Mortise Mill comes with a ¾" bit-and-bushing assembly and a handful of solid-wood tenons. You can also buy bit-and-bushing kits in ¼" (\$25) and ½" (\$33) for use with this model. Or, opt for the Pocket Zip Slot Mortise Mill (not shown), a smaller model that makes only ¼" mortises. Fifty ¼" tenons cost \$9, 40 ¾" tenons are \$13, and 30 ½" tenons are \$15.



(Editor's note: We tested two of each model. With the first units we had problems getting exact-fitting joints, a problem JessEm traced to faulty bushings. The second units we tested performed spot-on with no problems. JessEm's Patrick Curry said the company has resolved this issue, and that all units on the market have the new bushings.)

—Tested by Erv Roberts, a furniture builder for nearly 50 years



Zip Slot Mortise Mill

Performance	★★★★☆
Price	¾" standard model, #8100 \$250
	¼" pocket model, #8200 \$100
JessEm Tool Company	
866-272-7492; jessem.com	

This shop vacuum holds its own

Ridgid's Smart Cart shop vacuum solves many of the dilemmas common to tub-style vacuums, but it also creates a new problem. First, dust and chips don't build up on the filter—a nice 1-micron model that traps even fine dust—so I didn't have to stop and clean it as often, and it maintains good suction. Second, the two built-in drawers store the five accessory nozzles that always seem to fall off other vacuums, and the sturdy, flat lid works for temporary storage. Finally, this model is noticeably quieter than the screaming vacuum I've used for years. That's a relief for my ears.

But here's the problem: Smart Cart's 8'-long hose measures ½" smaller in diameter than Ridgid's old hose. That makes the 1¼"-diameter nozzle unusable in the more common 2½" ports on my router table and other tools without resorting to adapters or duct tape.

—Tested by Bob Hunter, Tools & Techniques Editor



Smart Cart wet-dry vacuum, #WD7000

Performance	★★★★☆
Price	\$200
Ridgid	
800-474-3443; ridgid.com	

continued on page 82



Truly Unique



Time travel at the speed of a 1935 Speedster?

The 1930s brought unprecedented innovation in machine-age technology and materials. Industrial designers from the auto industry translated the principles of aerodynamics and streamlining into everyday objects like radios and toasters. It was also a decade when an unequaled variety of watch cases and movements came into being. In lieu of hands to tell time, one such complication, called a jumping mechanism, utilized numerals on a disc viewed through a window. With its striking resemblance to the dashboard gauges and radio dials of the decade, the jump hour watch was indeed "in tune" with the times!

The Stauer 1930s Dashtronic deftly blends the modern functionality of a 21-jewel automatic movement and 3-ATM water resistance with the



True to Machine Art esthetics, the sleek brushed stainless steel case is clear on the back, allowing a peek at the inner workings.

distinctive, retro look of a jumping display (not an actual jumping complication). The stainless steel 1 1/2" case is complemented with a black alligator-embossed leather band. The band is 9 1/2" long and will fit a 7-8 1/2" wrist.

Try the Stauer 1930s Dashtronic Watch for 30 days and if you are not

receiving compliments, please return the watch for a full refund of the purchase price. If you have an appreciation for classic design with precision accuracy, the 1930s Dashtronic Watch is built for you. This watch is a limited edition, so please act quickly. Our last two limited edition watches are totally sold out!

Not Available in Stores

Stauer 1930s Dashtronic Watch \$99 +S&H or
3 easy credit card payments of \$33 +S&H
Call now to take advantage of this limited offer.

1-800-859-1602

Promotional Code DRW360-02
Please mention this code when you call.

Stauer 14101 Southcross Drive W.,
Dept. DRW360-02
Burnsville, Minnesota 55337
www.stauer.com

Amish mantle and miracle invention help home heat bills hit rock bottom

Miracle heaters being given away free with orders for real Amish fireplace mantles to announce the invention that helps slash heat bills, but Amish craftsmen under strain of Christmas rush force household limit of 2

Save money: only uses about 9¢ electric an hour; so turn down your thermostat and never be cold again

By MARK WOODS
Universal Media Syndicate

(UMS) Everyone hates high heat bills. But we're all sick and tired of simply turning down the thermostat and then being cold.

Well now, the popular HEAT SURGE® miracle heaters are actually being given away free to the general public for the next 7 days starting at precisely 8:00 a.m. today.

The only thing readers have to do is call the National Distribution Hotline before the 7-day deadline with their order for the handmade Amish Fireplace Mantle. Everyone who does is instantly being awarded the miracle heater absolutely free.

This is all happening to announce the HEAT SURGE Roll-n-Glow® Fireplace which actually rolls from room-to-room so you can turn down your thermostat and take the heat with you anywhere. That way, everyone who gets them first can immediately start saving on their heat bills.

Just in time for winter weather, portable Amish encased fireplaces are being delivered directly to the doors of all those who beat the deadline.

These remarkable fireplaces are being called a miracle because they have what's being called the *Fireless Flame*™ patented technology that gives you the peaceful flicker of a real fire but without any flames, fumes, smells, ashes or mess. Everyone is getting them because they require no chimney and no vent. You just plug them in.

The *Fireless Flame* looks



■ **GENUINE AMISH MANTLES MADE IN THE USA:** Everyone wants to save money on heat bills this winter, so entire Amish communities are working from the crack of dawn to finish. These fine real wood Amish made fireplace mantles are built to last forever. The oak mantle is a real steal at just two hundred ninety-eight dollars because all those who beat the order deadline by calling the National Hotline at 1-866-815-7004 to order the fireplace mantles are actually getting the imported hi-tech *Fireless Flame* HEAT SURGE miracle heaters for free.

so real it amazes everybody because it has no real fire. So what's the catch? Well, soft spoken Amish craftsmen who take their time hand building the mantles have a process that



■ **JUST ANNOUNCED:** The Heat Surge miracle fireplace has earned the prestigious Good Housekeeping Seal. The product has earned the Seal after evaluation by the Good Housekeeping Research Institute.

forces a strict household limit of 2 to keep up with orders.

"We can barely keep up ever since we started giving heaters away free. With winter just around the corner, everyone's trying to get them. Amish craftsmen are working their fingers to the bone to be sure everyone gets their delivery in time for Christmas," confirms Frederick Miller, National Shipping Director.

"These portable Roll-n-Glow Fireplaces are the latest home decorating sensation. They actually give you a beautifully redecorated room while they quickly heat from wall to wall. It's the best way to dress up every room, stay really warm and slash your heat bills all at the same

time," says Josette Holland, Home Makeover Expert.

And here's the best part. Readers who beat the 7-day order deadline are getting their imported hi-tech miracle heaters free when encased in the Amish built real wood fireplace mantles. The mantles are being handmade in the USA right in the heart of Amish country where they are beautifully hand-rubbed, stained and varnished.

You just can't find custom made Amish mantles like this in the national chain stores. That makes the oak mantle a real steal for just two hundred ninety-eight dollars since the entire cost of the miracle heater is free.

This free giveaway is the

HEAT SURGE™ Fireless Flame™

How It Works: The HEAT SURGE miracle heater is a work of engineering genius from the China coast so advanced, you simply plug it into any standard outlet. It uses only about 9¢ of electric an hour on the standard setting. Yet, it produces up to an amazing 5,119 BTU's on the high setting. So watch out, a powerful on board hi-tech heat turbine silently forces hot air out into the room from the vent so you feel the bone soothing heat instantly. It even has certification of Underwriters Laboratories coveted UL listing. It also comes with a limited full year replacement or money back warranty less shipping plus a 30-Day Satisfaction Guarantee. OH and FL resident transactions require the remittance of applicable sales tax. Sorry no shipments to MA residents.



LISTED: E322174



Hot air only comes out of the top vent

The hi-tech silent heat turbine takes in cold air

How to get 2 free heaters

The National Toll Free Hotlines are now open. All those who beat the 7-day order deadline to cover the cost of the Amish made Fireplace Mantle and shipping get the HEAT SURGE miracle heater free.

A strict limit of 2 per household has been imposed. Since some home woodworkers want to build their own mantle piece, they are letting people get the imported miracle heater alone for just \$249. Or, with the Amish made mantle you get the miracle heater free.

Use the map below to locate the weather zone you live in and call the Hotline number for your zone.



Claim Code: FP9661

EVERYONE LIVING IN THE

Frigid Zone: 1

START CALLING AT
8:00 A.M. TODAY
1-866-815-7004

EVERYONE LIVING IN THE

Cold Zone: 2

START CALLING AT
8:30 A.M. TODAY
1-866-815-7110

EVERYONE LIVING IN THE

Frost Zone: 3

START CALLING AT
9:00 A.M. TODAY
1-866-815-7112

FOR HEAT SURGE, LLC 8000 FREEDOM AVE., N. CANTON OH 44720

©2009 HEAT SURGE, LLC #4720A 09/08/09



■ **ON THEIR WAY:** Christmas orders have turned country roads into pipelines to the big city delivery system. Everybody wants a fireplace that comes fully assembled with a handmade Amish mantle in oak or cherry finish and gets delivered by truck right to your door. All you do is plug it in.

best way to slash heating bills and stay warm this fall and winter. The HEAT SURGE Roll-n-Glow Fireplace gives you zone heating and all the beauty and warmth of a built-in fireplace but rolls from room-to-room so it can also save you a ton of money on heating bills.

Even people in California and Florida are flocking to get them so they may never have to turn on their furnace all winter. And since it uses

only about 9 cents of electric an hour on the standard setting, the potential savings are absolutely incredible.

"We are making sure no one gets left out, but you better hurry because entire communities of Amish craftsmen are straining to keep up with demands. For now, we are staying out of the large national retail stores in order to let readers have two per household just as long as they call before the deadline," con-

firms Miller.

It's a really smart decision to get two right now because for only the next 7 days you get both miracle heaters free. That's like putting five hundred bucks right in your pocket and you can save even more money on your monthly heating bills.

"Everyone's calling to get one but those who are getting their Christmas shopping done are surprising the whole family by getting two. So when lines

are busy keep trying or log onto amishfireplaces.com. We promise to get to every call. Then we can have a delivery truck out to your door right away with your beautiful Heat Surge Roll-n-Glow Fireplace," Miller said.

"You'll instantly feel bone soothing heat in any room. You will never have to be cold again," he said. ■

On the worldwide web:
www.amishfireplaces.com

Rolls anywhere to throw an instant heat wave with no chimney, no vents, no wood and no smoke



■ **EASILY ROLLS ANYWHERE:** This is the portable Roll-n-Glow® Fireplace that easily rolls from bedroom to living room to keep you warm. No vents, no chimney and no tools. Just plug it in.



■ **SAVES ON BILLS:** Everyone can get low bills and stay warm and cozy. The Roll-n-Glow Fireplace saves a ton of money and makes your front room look like a million bucks.



■ **SAFE FLAME:** The Fireless Flame looks so real it fools everyone but there is no real fire. That makes the flame window safe to the touch under the watchful eye of a parent. It's where the kids will play and the cat and dog will sleep.



■ **FREE:** Get this \$249 miracle heater free. It is being given away free to all who beat the 7-day order deadline for your choice of the oak or cherry finish Amish Mantles. The free heater comes already encased.

Shop-Proven Products

continued from page 78

Long pins solve long-standing vessel-finishing problem

I turn mostly small hollow vessels in my shop, but I've always battled how best to secure them on the lathe while making the finishing cuts on the bottom side. The standard soft jaw pins—usually an inch or so long—on most flat-jaw chucks work great with platters and bowls because the largest diameter is typically on the open end against the chuck. But they're too short to grab vessels like the one shown at right.

So earlier this year I discussed this dilemma with Penn State's Ed Levy, who promptly made a set of 2½"-long jaw pins that fit into my chuck's jaws. Problem solved. Now I can shape and sand the bottoms and add finish knowing the rubber pins hold the vessels securely and without damaging the finished sides. These Soft Jaw Pins thread into the jaws of Penn State and Oneway chucks; check with Penn State for compatibility with other makes. 🌱

—Tested by Marlen Kemmet,
Managing Editor



Lathe Chuck Long Soft Jaw Pins, #LCJAWSJ

Performance	★★★★
Price	\$25
Penn State Industries	
800-377-7297; pennstateind.com	

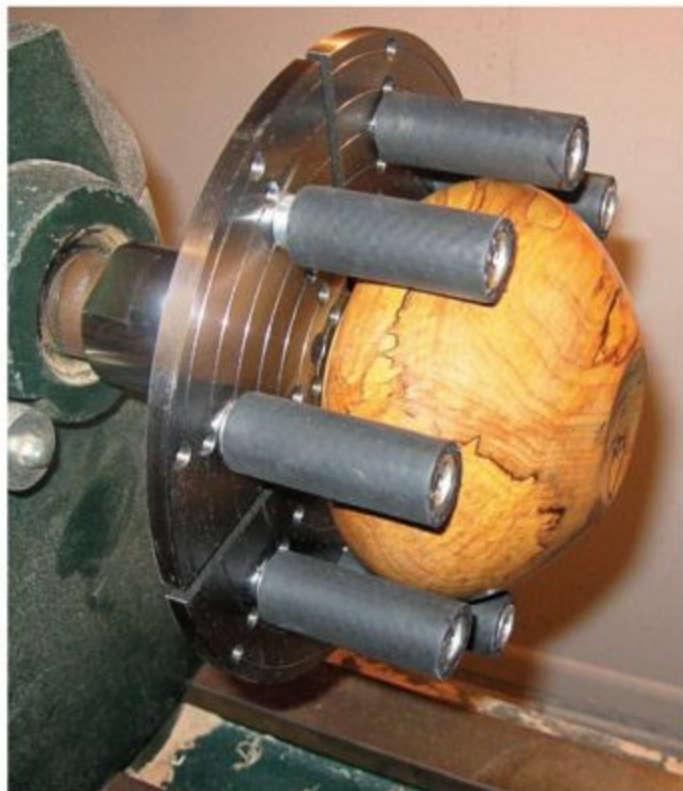

Air-Tech 750-ER
1050 MAX CFM
Remote Control
\$339.⁰⁰



**Award Winning
Air-Filtration and
Dust Collection**

www.jdstools.com

For more information call:
800.480.7269



HARBOR FREIGHT TOOLS

Quality Tools at the **LOWEST** Prices

FACTORY DIRECT TO YOU!

How does Harbor Freight Tools sell high quality tools at such ridiculously low prices? We buy direct from the factories who also supply the major brands and sell direct to you. It's just that simple! Come see for yourself at one of our 330 STORES NATIONWIDE and use this 20% OFF Coupon on any of our 7,000 products. We stock Automotive products, Shop Equipment, Hand Tools, Tarps, Compressors, Air & Power Tools, Material Handling, Woodworking Tools, Welders, Tool Boxes, Outdoor Equipment, Generators, and much more.

NOBODY BEATS OUR QUALITY, SERVICE AND PRICE!

WHY WE HAVE 10 MILLION SATISFIED CUSTOMERS:

- ✓ We Buy Factory Direct and Pass the SAVINGS on to YOU!
- ✓ Shop & Compare Our Quality Brands Against Other National Brands
- ✓ 7000 Tool Items In-Stock!
- ✓ NO HASSLE RETURN POLICY
- ✓ Family Owned & Operated

LIFETIME WARRANTY
ON ALL HAND TOOLS!

SUPER COUPON!

20% OFF

ANY SINGLE ITEM!

Bring this coupon and Save 20% on one single item purchased at Harbor Freight Tools. Cannot be used with any other discount or coupon. One coupon per purchase. One coupon per customer. Coupon not valid on prior purchases or purchase of gift cards or purchase of extended service plans. Offer good on in-stock merchandise only. Savings discount percentage off Harbor Freight Tools current prices, including sale prices. This coupon cannot be duplicated in any manner including photocopies and computer printouts. Original coupon must be presented in order to receive the discount. All Campbell Hausfeld products are excluded from this offer. This offer is not valid on food or beverage items sold in our retail stores. Valid only in Retail Stores through 3/17/10.



51915023

See HarborFreightusa.com/Wood for additional **SUPER COUPONS**

SUPER COUPON!

12" SLIDING COMPOUND MITER SAW WITH LASER GUIDE
CHICAGO
Electric Power Tools

LOT NO. 98194/96698/91852



SAW BLADE INCLUDED!

\$119.99

REGULAR PRICE \$199.99

Item 98194 shown

SAVE \$80



HARBOR FREIGHT TOOLS - LIMIT 1
These valuable coupons are only good when presented at your nearest Harbor Freight Tools store. Offer Ends 3/17/10. Coupons valid in Retail Store Only. Coupon not valid on prior purchases. Coupon cannot be bought, sold, or transferred. This coupon cannot be duplicated in any manner including photocopies and computer printouts. Original coupon must be presented in order to receive the discount.

SUPER COUPON!

CENTRAL MACHINERY
16" VARIABLE SPEED SCROLL SAW

LOT NO. 93012



\$49.99

REG. PRICE \$79.99

SAVE 37%



HARBOR FREIGHT TOOLS - LIMIT 1
These valuable coupons are only good when presented at your nearest Harbor Freight Tools store. Offer Ends 3/17/10. Coupons valid in Retail Store Only. Coupon not valid on prior purchases. Coupon cannot be bought, sold, or transferred. This coupon cannot be duplicated in any manner including photocopies and computer printouts. Original coupon must be presented in order to receive the discount.

SUPER COUPON!

LOT NO. 67256
MULTIFUNCTION POWER TOOL
CHICAGO
Electric Power Tools



\$29.99

REG. PRICE \$59.99

SAVE 50%



HARBOR FREIGHT TOOLS - LIMIT 1
These valuable coupons are only good when presented at your nearest Harbor Freight Tools store. Offer Ends 3/17/10. Coupons valid in Retail Store Only. Coupon not valid on prior purchases. Coupon cannot be bought, sold, or transferred. This coupon cannot be duplicated in any manner including photocopies and computer printouts. Original coupon must be presented in order to receive the discount.

SUPER COUPON!

CEN-TECH
12" COMBINATION SQUARE SET

LOT NO. 92471



\$5.99

REG. PRICE \$7.99

SAVE 25%



HARBOR FREIGHT TOOLS - LIMIT 1
These valuable coupons are only good when presented at your nearest Harbor Freight Tools store. Offer Ends 3/17/10. Coupons valid in Retail Store Only. Coupon not valid on prior purchases. Coupon cannot be bought, sold, or transferred. This coupon cannot be duplicated in any manner including photocopies and computer printouts. Original coupon must be presented in order to receive the discount.

SUPER COUPON!

ORBITAL HAND SANDER
DRILL MASTER

LOT NO. 40070



\$7.99

REG. PRICE \$17.99

SAVE 55%



HARBOR FREIGHT TOOLS - LIMIT 1
These valuable coupons are only good when presented at your nearest Harbor Freight Tools store. Offer Ends 3/17/10. Coupons valid in Retail Store Only. Coupon not valid on prior purchases. Coupon cannot be bought, sold, or transferred. This coupon cannot be duplicated in any manner including photocopies and computer printouts. Original coupon must be presented in order to receive the discount.

SUPER COUPON!

18 GAUGE COMBO NAILER/STAPLER KIT

CENTRAL PNEUMATIC
CONTRACTOR SERIES

Item 97525 shown

LOT NO. 97525/40115

WE CARRY A FULL LINE OF FASTENERS!



REG. PRICE \$34.99

\$14.99

SAVE 57%



HARBOR FREIGHT TOOLS - LIMIT 1
These valuable coupons are only good when presented at your nearest Harbor Freight Tools store. Offer Ends 3/17/10. Coupons valid in Retail Store Only. Coupon not valid on prior purchases. Coupon cannot be bought, sold, or transferred. This coupon cannot be duplicated in any manner including photocopies and computer printouts. Original coupon must be presented in order to receive the discount.

SUPER COUPON!

CENTRAL MACHINERY
OSCILLATING SPINDLE SANDER

LOT NO. 95088



REG. PRICE \$119.99

\$79.99

SAVE \$40



HARBOR FREIGHT TOOLS - LIMIT 1
These valuable coupons are only good when presented at your nearest Harbor Freight Tools store. Offer Ends 3/17/10. Coupons valid in Retail Store Only. Coupon not valid on prior purchases. Coupon cannot be bought, sold, or transferred. This coupon cannot be duplicated in any manner including photocopies and computer printouts. Original coupon must be presented in order to receive the discount.

SUPER COUPON!

12" RATCHET BAR CLAMP/SPREADER

LOT NO. 46807

REG. PRICE \$6.99

\$1.99

SAVE 71%



HARBOR FREIGHT TOOLS - LIMIT 4
These valuable coupons are only good when presented at your nearest Harbor Freight Tools store. Offer Ends 3/17/10. Coupons valid in Retail Store Only. Coupon not valid on prior purchases. Coupon cannot be bought, sold, or transferred. This coupon cannot be duplicated in any manner including photocopies and computer printouts. Original coupon must be presented in order to receive the discount.

We Will Beat Any Competitor's Price Within 1 Year Of Purchase!

330 STORES NATIONWIDE

TO FIND THE STORE NEAREST YOU CHECK:
1-800-657-8001
or HarborFreightusa.com/Wood

WOODCRAFT®

For A Free Catalog Or To Find Your Local Woodcraft Store, Visit www.woodcraft.com Or Call 800-225-1153.



WHITESIDE

"American Made for the American Woodworker"

- Made from solid alloy steel
- Precision ground for proper balance at high RPMs
- Uses the highest quality American made micrograin carbide
- High hook and relief angles make for better chip ejection
- Made with thick carbide for extra sharpenings
- Superior edge quality compared to other manufacturers
- Made with only high quality American made grinding wheels

108W010

QUALITY WOODWORKING TOOLS • SUPPLIES • ADVICE®

NEW INVENTION!

SPRING BOLT™

The Improved Wood Rail & Newel Post Fastener

Quickest, Easiest & Most Cost Effective

THREE REASONS TO QUALIFY SPRING BOLT AS THE BEST!

When it comes to attachment hardware you want to be "concealed". Meet the **SPRING BOLT!** A paddle bit, square drive and drill are the only tools you need to "Get It Done".

- Satisfy the architect, engineer, designer, customer and YOU
- No wood plugs or putty to detract from the finished product
- Has passed commercial load tests

Test result copies available upon request. Patent pending.



* SAVE 10 MIN OR MORE PER CONNECTION

* QUICK LEARN

* LOW UNIT COST

* LESS MAN MINUTES

* LOWER SKILL LEVEL

ROCK LOCK FASTENING SYSTEMS, INC.

877-577-BOLT | www.spring-bolt.com

High Quality Woodworking Tools at Low Prices

Air Locker

P630 23 Ga Micro

Pin Nailer Shoots

between 1/2" to 1 3/16"

23 Ga Pins. Also available as a kit

P630K including 1/2", 5/8", 3/4", 1",

1 3/16" 23 gauge pins for **\$59.99**



Air Locker

22 Ga Upholstery

Staplers U630 &

U630L (Extra Long Nose)

Uses 22 Ga 3/8" Crown

Senco & Porter Cable Staples

U630 \$39.99 U630L \$49.99



Maintenance Kits are also available

FACTORY RECONDITIONED TOOLS ARE ALSO AVAILABLE

Extensive Range of Woodworking Tools & Accessories by Best Brand Names
Amana Tool • Bosch • Dremel • Freud • Makita • Milwaukee • Templaco

Saws & Saw Blades



All types of Saws and Saw Blades

Routers & Bits



Routers, Router Bits & Accessories

Sanders



Widest selection of Sanders and Accessories by leading manufacturers

Jointers



Top of the line Jointers for home and professional woodworkers

Authorized Retailer for All Top Brands Including



www.ToolOrbit.com 888-722-8299

Largest selection of tools and accessories at unbeatable prices!

OSBORNE
Wood Products, Inc.

High Quality Wooden Components available in a variety of design styles.



866.849.8876

WWW.OSBORNEWOOD.COM

STATEMENT OF OWNERSHIP, MANAGEMENT, AND CIRCULATION

(Requester Publications Only) 1. Publication Title: Better Homes and Gardens WOOD
 2. Publication Number: 724-860. 3. Filing Date: 10/1/2009. 4. Issue Frequency: March, May, July, September, October, November, December/January. 5. Number of Issues Published Annually: 7. 6. Annual Subscription Price: \$20.00. 7. Complete Mailing Address of Known Office of Publication: 1716 Locust Street, Des Moines, IA 50309-3023.
 8. Complete Mailing Address of Headquarters or General Business Office of Publisher: 1716 Locust Street, Des Moines, IA 50309-3023. 9. Full Names and Complete Mailing Addresses of Publisher, Editor, and Managing Editor: Publisher: Mark Hagen, 333 North Michigan Avenue, Suite 1500, Chicago, IL 60601; Editor: Bill Krier, 1716 Locust Street, Des Moines, IA 50309-3023; Managing Editor: Marlon Kennert, 1716 Locust Street, Des Moines, IA 50309-3023. 10. Owner: Meredith Corporation, 1716 Locust Street, Des Moines, IA 50309-3023. The names and addresses of all stockholders owning or holding 1 percent or more of the total amount of stock: Banc of America Securities LLC, 100 W 33rd Street, 3rd Floor, New York, NY 10001; Bank of New York (The), One Wall Street, 6th Floor, New York, NY 10286; Brown Brothers Harriman & Co., 325 Washington Blvd, New Port Towers, Jersey City, NJ 07302; Charles Schwab & Co., Inc., Attn: Proxy Department, 211 Main Street, San Francisco, CA 94102; First Clearing, LLC, 10700 Highway First Drive, WS 1023, Glen Allen, VA 22060; Goldman, Sachs & Co., 30 Hudson Street, Proxy Department, Jersey City, NJ 07302; JP Morgan Chase Bank, 140 Wall Street, 8 Wing Floor 6, Mind Space, Malad (W), Mumbai 400 064, India; JP Morgan Chase Bank, National Association, Paradigm, B Wing, Floor 6, Mind Space, Malad (W), Mumbai 400 064, India; Mellon Trust of New England, National, 525 William Penn Place, Suite 3418, Pittsburgh PA 15259; Northern Trust Company (The), 801 S Canal Street, Attn: Capital Structures-C1N, Chicago IL 60607; PNC Bank, National Association, 8800 Trinum Blvd, MS F6-206-02-2, Philadelphia PA 19153; State Street Bank and Trust Company, Attn: Paul Deshaemais, 1770 Heritage Dr., Newbury Park, CA 91321; UMB Bank, National Association, Attn: Jai Guzman, 925 Grand Blvd, Kansas City, MO 64109; U.S. Bank, N.A., Attn: Securities Control, 1555 N. Riverside Dr., Ste 302, Milwaukee, WI 53212. Through some of the nominees listed above, the E. T. Meredith and Bohan families and family foundations own, directly or beneficially, approximately 20% of the issued and outstanding stock of the corporation. Each nominee listed above holds stock for one or more stockholders.
 11. Known Bondholders, Mortgagees, and Other Security Holders Owning or Holding 1 Percent or More of Total Amount of Bonds, Mortgages, or Other Securities: None. 12. Tax Status (For completion by nonprofit organizations authorized to mail at nonprofit rates) (check one): The purpose, function, and nonprofit status of this organization and the exempt status for federal income tax purposes: Has Not Changed During Preceding 12 Months. Has Changed During Preceding 12 Months (Publisher must submit explanation of change with this statement) Not applicable.
 13. Publication Title: Better Homes and Gardens WOOD
 14. Issue Date for Circulation Data Below: November 2009
 15. Extent and Nature of Circulation

Average No. Copies Each Issue During Preceding 12 Months:
 a. Total Number of Copies (Net Press Run): 605,846
 b. Legitimate Paid and/or Requested Distribution (By Mail and Outside the Mail):

- (1) Outside County Paid/Requested Mail Subscriptions Stated on PS Form 3541. (Include direct written request from recipient, telemarketing and internet requests from recipient, paid subscriptions including nominal rate subscriptions, employer requests, advertiser's proof copies, and exchange copies): 450,746
 (2) In-County Paid/Requested Mail Subscriptions Stated on PS Form 3541. (Include direct written request from recipient, telemarketing and internet requests from recipient, paid subscriptions including nominal rate subscriptions, employer requests, advertiser's proof copies, and exchange copies): 670
 (3) Sales Through Dealers and Carriers, Street Vendors, Counter Sales, and Other Paid or Requested Distribution Outside USPS: 30,000
 (4) Requested Copies Distributed by Other Mail Classes Through the USPS (e.g. First-Class Mail®): 0
 c. Total Paid and/or Requested Circulation (Sum of 15b (1), (2), (3), and (4)): 481,416
 d. Nonrequested Distribution (By Mail and Outside the Mail):
 (1) Outside County Nonrequested Copies Stated on PS Form 3541 (include Sample copies, Requests Over 3 years old, Requests induced by a Premium, Bulk Sales and Requests including Association Requests, Names obtained from Business Directories, Lists, and other sources): 32,740
 (2) In-County Nonrequested Copies Stated on PS Form 3541 (include Sample copies, Requests Over 3 years old, Requests induced by a Premium, Bulk Sales and Requests including Association Requests, Names obtained from Business Directories, Lists, and other sources): 0
 (3) Nonrequested Copies Distributed Through the USPS by Other Classes of Mail (e.g. First-Class Mail, Nonrequestor Copies mailed in excess of 10% Limit mailed at Standard Mail® or Package Services Rates): 0
 (4) Nonrequested Copies Distributed Outside the Mail (include Pickup Stands, Trade Shows, Showrooms and Other Sources): 0
 e. Total Nonrequested Distribution (Sum of 15d (1), (2), and (3)): 32,740
 f. Total Distribution (Sum of 15c and e): 514,156
 g. Copies not Distributed (See Instructions to Publishers #4 (page 93)): 91,690
 h. Total (Sum of 15f and g): 605,846
 i. Percent Paid and/or Requested Circulation (15c divided by 15f times 100): 8363

- No. Copies of Single Issue Published Nearest to Filing Date:
 a. Total Number of Copies (Net Press Run): 610,824
 b. Legitimate Paid and/or Requested Distribution (By Mail and Outside the Mail):
 (1) Outside County Paid/Requested Mail Subscriptions Stated on PS Form 3541. (Include direct written request from recipient, telemarketing and internet requests from recipient, paid subscriptions including nominal rate subscriptions, employer requests, advertiser's proof copies, and exchange copies): 456,378
 (2) In-County Paid/Requested Mail Subscriptions Stated on PS Form 3541. (Include direct written request from recipient, telemarketing and internet requests from recipient, paid subscriptions including nominal rate subscriptions, employer requests, advertiser's proof copies, and exchange copies): 673
 (3) Sales Through Dealers and Carriers, Street Vendors, Counter Sales, and Other Paid or Requested Distribution Outside USPS: 30,571
 (4) Requested Copies Distributed by Other Mail Classes Through the USPS (e.g. First-Class Mail®): 0
 c. Total Paid and/or Requested Circulation (Sum of 15b (1), (2), (3), and (4)): 487,622
 d. Nonrequested Distribution (By Mail and Outside the Mail):
 (1) Outside County Nonrequested Copies Stated on PS Form 3541 (include Sample copies, Requests Over 3 years old, Requests induced by a Premium, Bulk Sales and Requests including Association Requests, Names obtained from Business Directories, Lists, and other sources): 20,523
 (2) In-County Nonrequested Copies Stated on PS Form 3541 (include Sample copies, Requests Over 3 years old, Requests induced by a Premium, Bulk Sales and Requests including Association Requests, Names obtained from Business Directories, Lists, and other sources): 0
 (3) Nonrequested Copies Distributed Through the USPS by Other Classes of Mail (e.g. First-Class Mail, Nonrequestor Copies mailed in excess of 10% Limit mailed at Standard Mail® or Package Services Rates): 0
 (4) Nonrequested Copies Distributed Outside the Mail (include Pickup Stands, Trade Shows, Showrooms and Other Sources): 0
 e. Total Nonrequested Distribution (Sum of 15d (1), (2), and (3)): 20,523
 f. Total Distribution (Sum of 15c and e): 510,145
 g. Copies not Distributed (See Instructions to Publishers #4 (page 93)): 100,679
 h. Total (Sum of 15f and g): 610,824
 i. Percent Paid and/or Requested Circulation (15c divided by 15f times 100): 9598

16. Publication of Statement of Ownership for a Requester Publication is required and will be printed in the December/January 2010 issue of this publication.
 17. Signature and Title of Editor, Publisher, Business Manager, or Owner: Jeff Stiles, Business Manager. Date: 06/25/09. I certify that all information furnished on this form is true and complete. I understand that anyone who furnishes false or misleading information on this form or who omits material or information requested on the form may be subject to criminal sanctions (including fines and imprisonment) and/or civil sanctions (including civil penalties).

85



Industrial Blade Company

Presents: PINNACLE Replacement Plane Blades

Why is IBC the Best-Kept Secret in Woodworking?

The evidence of IBC's plane blade manufacturing expertise is extensive, but the name is still vastly unknown to woodworkers. IBC™ is proud to finally and formally introduce itself to the woodworking industry with an extensive product line of premium replacement blades. Instead of being the best-kept secret in the woodworking industry, the goal of the IBC™ brand is to become synonymous with "the best plane irons in woodworking."



Made in Canada



Replacement Plane Blades For Traditional STANLEY® Planes



Replacement Plane Blades For Lie-Nielsen® Planes



Replacement Plane Blades For Veritas® Planes

PROFESSIONAL QUALITY TOOLS™

Available Exclusively At Woodcraft® For A Free Catalog Or To Find Your Local Woodcraft Store, Visit woodcraft.com Or Call 800-225-1153. 10101010

Families Have Saved Up To 50% On Heating Costs

And never have to buy fuel — oil, gas, kerosene, wood — ever again!



Lifetime Warranty

Your Benefits with Hydro-Sil:

- Slash heating cost with Hydro-Sil
- Furnace free — duct free
- Lifetime warranty. No service contracts
- Safe, complete peace of mind
- Clean, no fumes, environmentally safe
- U.L. listed
- Preassembled — ready to use
- Portable (110V) or permanent (220V)
- Whole house heating or single room

Contact us today for info and FREE catalog!

Hydro-Sil is a high performance individual room heating system that can save you hundreds of dollars in home heating costs by replacing old and inefficient heating. It can replace or supplement your electric heat, gas or oil furnace and woodstoves.

Hydro-Sil represents economy in heating: inside the heater is a sealed copper chamber filled with a harmless silicone fluid designed for heat retention qualities. The fluid is quickly heated by a varying amount of micro-managed proportional power. This exclusive technology greatly increases energy savings.

220 VOLT PERMANENT	Approx. Area to Heat	S&H	Discount Price	Qty.
8' 2000 w	250-300 sf	\$25	\$319	
6' 1500 w	180-250 sf	\$25	\$289	
5' 1250 w	130-180 sf	\$25	\$259	
4' 1000 w	100-130 sf	\$18	\$239	
3' 750 w	75-100 sf	\$18	\$189	
2' 500 w	50-75 sf	\$18	\$169	
Thermostats — Call for options & exact heater needed.				
110 VOLT PORTABLES (Thermostat included.)		S&H	Discount Price	Qty.
5' Hydro-Max 750-1500 w		\$25	\$229	
3' 750 w — Silicone		\$18	\$179	
Heavy-Duty 240v		\$25	\$329	
Total Amount				

Check ■ MasterCard ■ Visa ■ Discover

1-800-627-9276

www.hydrosil.com

Hydro-Sil, P.O. Box 662, Fort Mill, SC 29715

Name _____
 Address _____
 City _____ St _____
 Zip _____ Phone _____
 MasterCard, Visa or Discover Account Information:
 Acct # _____
 Expiration Date _____

FREE Product Information from Advertisers in This Issue

Looking for FREE product information? Fill out the coupon in this section to receive FREE product info and catalogs. Or, for quicker service and instant access to information, visit us online at www.woodworkerscenter.com

Adhesives & Finishes

TITEBOND® III ULTIMATE WOOD GLUE

Superior bond strength, waterproof, longer open-assembly time. The Best Wood Glue Ever! **Circle No. 24.**

GORILLA WOOD GLUE High strength, shorter clamp time, and no dyes for a natural finish. Try it today on your next building project. **Circle No. 50.**

UNITED GILSONITE LABORATORIES

Finishing Touch Brochure — guide for best results using ZAR Wood Stain/Finishes. **Circle No. 128.**

Bits, Blades, Cutting Tools

CMT ORANGE TOOLS Top quality industrial saw blades and router bits at affordable pricing. **Circle No. 180.**

EAGLE AMERICA Largest selection of professional quality, American-made router bits + 100's of unique accessories. **Circle No. 193.**

FORREST MFG. CO., INC. Top quality blades and dados for an ultra smooth finish. **Circle No. 206.**

FREUD SAW BLADES This 48-page catalog illustrates the features and benefits for all Freud saw blades. **Circle No. 219.**

FREUD ROUTER BITS All Freud router bits are represented in this 84-page catalog, including more than 130 new bits and sets. **Circle No. 232.**

SAWSTOP SawStop table saws stop the blade upon contact with skin. **Circle No. 280.**

SOMMERFELD'S TOOLS FOR WOOD

Router Bits, Blades, Tools and Tips. FREE catalog & shipping! **Circle No. 284.**

Books, Plans and Videos

AMERICAN FURNITURE DESIGN CO. 150 of America's best furniture plans, comprehensive instruction guide. Catalog. **Circle No. 336.**

MEISEL HARDWARE SPECIALTIES

CATALOG 2,000+ full-size project plans and hard-to-find hardware. **Circle No. 401.**

U-BILD WOODWORKING PLANS

Since 1948! Hundreds of full-size plans, downloadable plans, low prices. **Circle No. 435.**

General Woodworking Catalogs

ARMOR CRAFTS Full-size plans to build cradles, rocking horses, clocks and more. Also hardware and wood craft supplies. **Circle No. 556.**

THE BEALL TOOL COMPANY Inventive solutions for shop problems: wood threading, buffing & more. **Circle No. 558.**

GRIZZLY INDUSTRIAL, INC. 12,000 woodworking and metalworking machines, tools and accessories — unbeatable prices! **Circle No. 583.**

PEACHTREE WOODWORKING SUPPLY "Your One Stop Supply Shop" — over 4,000 items. **Circle No. 654.**

ROCKLER WOODWORKING & HARDWARE Our premium tools make woodworking efficient and enjoyable. FREE Catalog. **Circle No. 661.**

WOODCRAFT SUPPLY CORP. Over 15,000 top quality woodworking tools, supplies, and accessories. **Circle No. 700.**

Hand Tools, Jigs & Clamps

AFFINITY TOOL WORKS Manufacturer of quality hand tools and products for cabinetmaking, carpentry, woodworking. **Circle No. 734.**

KREG TOOL CO. Your one stop shop for everything Pocket-Screw related. **Circle No. 802.**

MORTISE PAL Mortises made easy! **Circle No. 824.**

STANLEY SWEETHEART HAND PLANES New Sweetheart premium hand planes by Stanley. **Circle No. 829.**

Hardwood & Lumber

STEVE H. WALL LUMBER CO. Quality hardwoods, plywood, exotic lumber. Ship UPS/motor freight, wholesale prices. **Circle No. 856.**

WOODWORKERS SOURCE Hardwoods from around the world. **Circle No. 869.**

Income Opportunities & Education

MARC ADAMS SCHOOL OF WOODWORKING Over 125 summer hands-on workshops with the best instructors of modern time. **Circle No. 916.**

PROFURNITUREBUILDER.COM ProFurnitureBuilder.com from Meadowbrook Creations. Start your own made-to-order furniture business. **Circle No. 919.**

WOODCRAFT RETAIL FRANCHISE Own a Woodcraft Store — franchises offered for stores across the country. **Circle No. 924.**

Kits

KLOCKIT The leading supplier of clock-making supplies for over 35 years! **Circle No. 973.**

WOODEN-GEAR-CLOCKS.COM Create a wooden gear clock—kits and plans available. **Circle No. 1008.**

Miscellaneous

APOLLO SPRAYERS TURBINE SYSTEMS Quality control, engineering and durability. **Circle No. 1061.**

AZTEC STEEL CORP. Quality pre-engineered arch-style steel buildings at the lowest cost anywhere. **Circle No. 1064.**

CENTRAL BOILER Classic Wood Furnaces — clean, safe, efficient heat for your home. **Circle No. 1105.**

DAKOTA ALERT, INC. An alert sounds in the house when someone enters the drive. **Circle No. 1129.**

HYDRO-SIL Unique room-by-room heating system. **Circle No. 1190.**

RADIANT FLOOR COMPANY Radiant Heating Systems—design, manufacture and sale for the DIY. **Circle No. 1301.**

ROCK LOCK FASTENING SYSTEMS, INC. Post and railing attachment hardware that makes it easy. **Circle No. 1308.**

Power Tools

BOSCH POWER TOOLS Bosch Pneumatics Fastening System with Full Force Technology is 20% more compact. **Circle No. 1459.**

COOK'S SAW MFG., L.L.C. Portable sawmills, Edgers, Sharpeners, Band Blades... Free catalog. Video available. **Circle No. 1480.**

FREUD POWER TOOLS 16-page catalog illustrates dependable power tools with traditional Freud quality. **Circle No. 1532.**

GRANBERG INTERNATIONAL Alaskan Saw Mill, chain saw accessories. Made in USA. **Circle No. 1558.**

GREX POWER TOOLS Professional fastening systems and pneumatic powered hand tools. **Circle No. 1573.**

LAGUNA TOOLS Fine woodworking machines for professionals and hobbyists. Award-winning design bandsaws, European quality machines with over 25 years of experience. **Circle No. 1593.**

PLASMA CAM, INC. Put metal into your wood projects! Free Demo Video! **Circle No. 1641.**

WORK SHARP Sharpen your woodworking tools with the new WORK SHARP. **Circle No. 1665.**

RADARCARVE Manufacturer of specialized wood carving duplicators. **Circle No. 1673.**

STANLEY-BOSTITCH FINISH NAILERS & STAPLERS The preferred brand among professionals when it comes to finish nailers and staplers. **Circle No. 1768.**

TOOLMART INC. Woodworking tools and accessories by top brands: Delta, DeWalt, Porter Cable, Jet, Powermatic. **Circle No. 1770.**

WOOD-MIZER PRODUCTS Eight Portable Sawmills Available starting with the LT10 at \$3995. **Circle No. 1805.**

WOODMASTER TOOLS Multi-duty planers that mold, sand & saw. **Circle No. 1820.**

Project Parts & Materials

OSBORNE WOOD PRODUCTS, INC. A free catalog of table legs, corbels, and island legs. **Circle No. 1849.**

OSBORNE WOOD PRODUCTS, INC. WOOD CORBELS offer classic corbels in a broad range of styles. **Circle No. 1851.**

Shop Accessories

CARTER PRODUCTS COMPANY, INC. Bandsaw Guide kits, tires, stabilizer guides, and many other products. **Circle No. 1883.**

THE JDS COMPANY Specializing in the finest air filtration and dust collection equipment. **Circle No. 1974.**

LIGNOMAT USA, LTD. Affordable, reliable, pin and pinless moisture meters for wood. Free catalog. **Circle No. 2013.**

ONEIDA AIR SYSTEMS, INC. Free informative catalog contains dust collection systems and complete ductwork. **Circle No. 2039.**

PENN STATE INDUSTRIES Award-winning dust collection. Collectors, Cyclones, Ductwork and more. **Circle No. 2045.**

PHASE-A-MATIC, INC. Convert 1-phase electric power into 3-phase; run 3-phase equipment anywhere. **Circle No. 2052.**

RED HILL CORP. SUPERGRIT® ABRASIVES Industrial quality sanding belts, discs, rolls, sheets at wholesale prices to small consumers. **Circle No. 2065.**

Woodturning Supplies

BEREA HARDWOODS Quality pen kits and other turning kits. **Circle No. 2127.**

HUT PRODUCTS Woods, acrylics and supplies for pen and game call turning. **Circle No. 2133.**

PACKARD WOODWORKS Free Catalog for WOODTURNERS! — Quality Lathes, Tools and Supplies. **Circle No. 2143.**

PENN STATE INDUSTRIES Leading supplier of Turning Products. Pen kits, project, finishes and more. **Circle No. 2151.**

Log on to www.WOODWorkersCenter.com

Shape Up Your Workshop!



Plan, build, equip, light, and organize your home workspace to realize your dreams.

On Newsstands NOW!

\$6.99 U.S.
\$8.99 Canada

Order online at woodmagazine.com/publications

or call toll free **888-636-4478**

WD1209

WOODWorkersCenter.com

FREE Product Information

DEPT. W06E09

CIRCLE THE NUMBERS BELOW CORRESPONDING TO ITEMS IN THIS ISSUE.

24	280	654	869	1105	1558	1805	2045
50	284	661	916	1129	1573	1820	2052
128	336	700	919	1190	1593	1849	2065
180	401	734	924	1301	1641	1851	2127
193	435	802	973	1308	1665	1883	2133
206	556	824	1008	1459	1673	1974	2143
219	558	829	1061	1480	1768	2013	2151
232	583	856	1064	1532	1770	2039	4000

Discover how rewarding woodworking can be! Get one full year of WOOD® for just \$28.00 (7 issues). Simply circle No. 4000. You will be billed later.

NAME _____
ADDRESS _____
CITY _____ STATE _____ ZIP _____
E-MAIL ADDRESS _____
PHONE (OPTIONAL) _____

TO ENSURE PROMPT HANDLING OF YOUR ORDER, PLEASE:

- Circle Your Choice(s) in the box above
- Send card to WOOD® Magazine, Dept. W06E09, P.O. Box 5135, Buffalo, NY 14205-5135
- Allow 4-6 weeks for delivery
- This card expires May 18, 2010

LOGS TO LUMBER

MAKE YOUR OWN LUMBER & SAVE MONEY

Eight Sawmill Models Available

2 YEAR WARRANTY

Wood-Mizer
800.553.0182
www.SawBoards.com

Nancy's Rocker & Footstool

Most woodworkers' "want-a-do list" of projects includes building a "Maloo Inspired" rocking chair. Our 34 page instruction booklet with color photos, and two 36" x 48" full-size patterns provide you with all the knowledge and confidence you will need to build Nancy's Rocker and the matching footstool, also shown full size.....! Actually with our plan you get two great design projects...

FREE CATALOG

Plan #415

AMERICAN FURNITURE DESIGN
P.O. BOX 390100 ESCONCIDO, CA 92030
Nancy's Rocker & Footstool \$45.98 + \$7.00 S/H
www.americanfurnituredesign.com

CLAMP EDGE

TOOL GUIDE

22.5°

APPROX TOOL WORKS, LLC
(888) 508-0316
www.approxtoolworks.com

Best-Ever Mission Bedroom Suite Plans

Arts and Crafts Bed Plan
DP-00424 \$9.95



Dresser Plan
DP-00440 \$9.95

Supergrit® SANDPAPER

HOOK & LOOP DISCS

2"	\$18/100	3"	\$20/100
4" or 5"	5 or 8 Holes	\$15.00/50	
6"	6, 8, or 16 Holes	\$17.00/50	
9"	\$1.50 ea	12"	\$2.75 ea

ABRALON® 6" Polishing H&L Discs
Grits 300 to 4000

ABRANET® 3", 5" & 6" Mesh Discs
Grits 80 to 600

MIRKA
INDASA

BELTS—A.O. Resin		SHEETS—9" x 11" A.O.	
1 x 30	\$.85	500, 800	\$16/50
1 x 42	\$.90	120C, 150C	\$26/100
3 x 21	\$1.00	180A, 220A	\$23/100
3 x 24	\$.90		

ABRASIVE ROLLS

RED HILL CORP.
P.O. BOX 4234
GETTYSBURG, PA 17325
WWW.SUPERGRIT.COM

FREE 48 PAGE CATALOG
& incredible close-out sheets
(800) 822-4003

KLOCKIT

Leading Supplier To WoodWorkers For 37 Years!

Call Today
For Your
FREE
Catalog!

www.klockit.com



Blanket Chest Plan
DP-00446 \$8.95



Nighstand Plan
DP-00433 \$7.95

Your 4-Season Business

Build 30+ Products Proven to Sell
Get all you need to be successful

Marketing Know-how
40 Page Web Site
Catalogs
Brochures

Protected Territory

0% Financing

ProFurnitureBuilder.com

Klockit Offers The Largest Selection Of Clock:
Movements • Dials • Hands
• Kits • Plans • Hardware & Much More!

1-800-556-2548

Dept: WD1209

Download any of these woodworking plans for the prices listed, or view a larger image, at woodmagazine.com/plans
To have paper plans mailed directly to you (add \$3 per plan plus S+H), call toll-free 1-888-636-4478.
Please have your credit card available.

Great Investment



High Quality American Steel Span buildings make a great investment, perfect for a workshop, ideal for a garage.



Maintenance-Free • Savings Up to 60%



www.steelspan.com
800-891-6733 ext 018



Your Source for Wood

Lumber • Veneer • Turning Stock
 Domestic & Exotic

800.423.2450



Over 100 beautiful woods.
 Secure online ordering.

www.101woods.com

Mortise Pal™

PRECISION MORTISING JIG



MORTISES MADE EASY!

WWW.MORTISEPAL.COM
 RG Jig Co. Tel: 619-459-7951 Fax: 619-548-3511
 4580 ALVARADO CANYON RD. STE. E, SAN DIEGO, CA 92120

Saw Your Own Lumber!

With the Original 'Heavy Built' Mill

*10hp-30hp Models *19" Metal Bandwheels
 *12 or 120 Volt Options *32" Diameter Log Cut
 *Package Deals Available

FREE Catalog!



Cut Wood For:
 •Home •Barn •Fencing
 •Stables •Decking

1-800-473-4804

www.cookssaw.com

Create A Classic



Baby Cradle Build Plan # M62 These Classics With Our Full Size Plans
 Size 21x35x39
 \$15.95
 more info at armorplans.com



Cycle Rocker Plan # M82 \$18.50
 Size 44 L x 27 H
 Trim pack info at armorplans.com

VISA/MC 1-800-292-8296
 Armor Box 445 E. Northport NY 11731

WEEK LONG & WEEKEND WORKSHOPS
 RUNNING APRIL - OCTOBER



SCHOOL OF WOODWORKING
 marc ADAMS

2010 CLASSES

- Cabinet Making • Carving
- Chair Making • Design
- Finishing • Furniture Making
- Joinery • Turning
- Veneering • Marquetry
- And Much More!

www.marcadams.com

5504 E 500 N • FRANKLIN, IN 46131

317-535-4013 • FAX 317-535-1713

marc@marcadams.com

Masters Programs & Scholarships Available

Make Time!

Create your own wooden gear clock!

Need just the pattern?
 Or the complete kit?
 Build it YOUR way!

Wooden-Gear-Clocks.com
 clocks, kits, and do-it-yourself patterns
(715) 955-4104
www.wooden-gear-clocks.com

U-BILD.COM



On-line catalog pictures hundreds of full-size woodworking plans at low prices, plus more than 30 downloadable plans. Indoor, outdoor, kids and holiday projects for all skill levels.

(800) 82-U-BILD

PHASE-A-MATIC™

PHASE CONVERTERS



CONVERTS 1-PHASE to 3-PHASE POWER!

1-800-962-6976

www.phase-a-matic.com

MOISTURE METER

mini-Ligno E/D:

- Accuracy
- Quality
- Durability
- 2-Year Warranty

Avoid
frustrating problems
loose joints
delamination
shrinking
warping



Lignomat USA LTD 800-227-2105
PO Box 30145, Portland, OR 97294
www.lignomat.com
E-mail: sales@lignomat.com

Turn to Quality



Shop
on-line



www.hutproducts.com
1-800-547-5461



Wireless Driveway Alarm



Alerts you when someone is walking or driving onto your property.

Free Literature

Dakota Alert

PO Box 130, Elk Point, SD 57025
605-356-2772 • www.dakotaalert.com

Knifemaking Made Easy!

Still Time For Gift Giving!

1-800-351-8900

Prestige Cutlery

High quality 440C surgical stainless blades satin finish, sharpened to an exceptional edge. Handles predrilled. Easy to complete with rivets, handle material, detailed instructions.



SS809\$99.95

Full Color 100 pg Catalog \$5.00 Free while

JANTZ SUPPLY

309 WEST MAIN-DEPT WD - DAVIS OK 73030

www.knifemaking.com

Knife making kits, Metals, Exotic Woods, Horn, Pearl, Ivory, Abrasives, Polishing And Finishing Supplies, Precision Tools, Schrenshaw and Leathercraft Supplies, Books, Videos, And More!

Better Homes and Gardens®

WOOD MAGAZINE

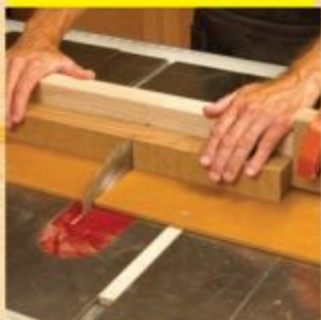

For advertising in the Woodworkers' Marketplace,
please call Lisa Greenwood at 1-800-950-3829 or

lisa.greenwood@meredith.com

STEVE WALL LUMBER CO.

Quality Hardwoods and Woodworking machinery For The Craftsman and Educational Institutions

Ash	4/4	Select	\$ 2.60
Basswood	4/4	Select	\$ 1.95
Birch	4/4	Select	\$ 3.55
Butternut	4/4	1C	\$ 2.95
Cherry	4/4	Select	\$ 4.90
Hickory - Pecan	4/4	Select	\$ 3.00
Mahogany (Genuine)	4/4	Select	\$ 4.70
Maple (Hard)	4/4	Select	\$ 3.45
Maple (Soft)	4/4	Select	\$ 2.50
Poplar	4/4	Select	\$ 1.80
Red Oak	4/4	Select	\$ 2.70
Walnut	4/4	Select	\$ 4.90
White Oak	4/4	Select	\$ 2.70
Cedar (Aromatic Red)	4/4	1C+Btr.	\$ 1.80
Cypress	4/4	Select	\$ 2.60
White Pine	4/4	F.G.	\$ 1.25
Yellow Pine	4/4	Clear	\$ 2.30

Above prices are for 100' quantities of kilndried rough lumber sold by the Bd. Ft. FOB Mayodan, NC. Call for quantity discounts. Other sizes and grades available.

UPS Specials

SEE OUR CATALOG ON THE WEB!

Above prices are 20 bd. ft. bundles of clear kilndriedlumber 3'-10" wide x 3'-5" long (Random widths & lengths) Surfaced 2 sides or rough. Delivered UPS prepaid in the Continental U.S.

OLIVER MACHINERY DEALER

- HARDWOOD PLYWOOD
- CUSTOM RAISED PANEL DOORS
- CUSTOM FLOORING
- HARDWOOD FLOORING
- THIN CRAFTWOOD
- EXOTIC LUMBER

STEVE H. WALL LUMBER CO.

BOX 287
MAYODAN, N.C. 27027
336-427-0637
1-800-633-4062
FAX 336-427-7588

Email: wood@walllumber.com
Website: www.walllumber.com
Send \$1.00 For Lumber Catalog
Prices Subject to Change Without Notice

INFINITY IMPROVED

Replacement HSS Knives
DEWALT DW735 PLANER

- ✓ Lasts Longer
- ✓ Thicker
- ✓ Stronger



Item: HSSK-041 **Only \$79.90**

infinitytools.com | 877-USA-BITS

Projects and Plans



Wheelbarrow

Kit to build includes 1.5" iron wheel that really works, axle and step-by-step plans. Finished project measures 66"L x 24"W x 26"H. \$39.95 plus S/H

ByeGone Workshop
888-279-3941 8-5 M-F EST
www.bye-gone.com

Woodworking Plans!



For Free Catalog Mention Offer #1266 1-800-441-9870
Melsel Hardware Specialties P.O. Box 70,
Mound, MN 55354 www.melselwoodhobby.com

TURN AND BURN WITH PACKARD WOODWORKS

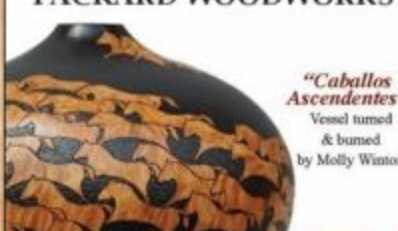

"Caballos Ascendentes"
Vessel turned & burned
by Molly Winton

1-800-683-8876
PACKARDWOODWORKS.COM
Packard WOODWORKS
The Woodturner's Source

STOP BUYING LUMBER!

Use your chain saw and Granberg's mill to create perfect slabs of wood

1. MKIII Attachment
Easily Mounts on Bar
Saws from 24" to 56"
2. MINI MILL Attachment
Great partner for MKIII
Ideal for edging and
reducing log diameters
3. SMALL LOG Attachment
Add to chain saw and
start making lumber!



WWW.GRANBERG.COM
CALL NOW FOR FREE CATALOG! 800-233-6499
50 Years of Customer Satisfaction!

TILT BOX

Magnets on the sides cling to metal surfaces.

Reads relative angles to .1 degrees

Also gauges actual level

THE BEALL TOOL CO.
541 Swans Road N.E. Newark Ohio Deps.
1-800-331-4718 www.bealltool.com WM

WOOD HEAT

CENTRAL BOILER E-CLASSIC 2300

Outdoor Wood Gasification Furnace

- Heat your entire home, water and more*
- Adapts easily to new or existing heating systems.
- Over 85% efficient. Burns half the wood of conventional wood heating.
- EPA Phase 2 qualified.

*Furnace and system must be properly sized and installed.

Central Boiler
Find your nearest dealer at:
centralboiler.com
800-248-4661
©2009 Central Boiler 051414

WWW.RADARCARVE.NET Wood Carving Duplicators

- Furniture
- Gunstocks
- Millwork
- Decoys
- Musical Instruments



Thousands of Uses 505-948-0571

DOWELMAX

WE GUARANTEE THE STRONGEST, MOST ACCURATE JOINING SYSTEM ON THE PLANET.
DID WE ALSO MENTION THE VERSATILITY?

4 Dowel application on crown moulding

Flawless crown moulding joint ready for priming and painting

www.dowelmax.com Toll Free 1-877-986-9400

What's Ahead

A sneak peek inside the March 2010 issue (on sale January 19)

COVER ARTICLE



Pine cabinet

Not too big, not too small—this hutch is just the right size. Construction goes quickly, thanks to biscuit joinery. Adjustable no-mortise hinges make it easy to hang and position the doors perfectly.



Cook up a kitchen makeover in your shop

Avoid the cost of a completely new kitchen by bringing yours back to life with new doors, drawers, and built-ins. It's a project that pays for itself (and maybe some new tools for you, too).



The sizzle on chisels

Need chiseled abs? Sorry, can't help you there. But renowned craftsman and educator Tim Peters, above, will show you how to work wood with all types of chisels.



Wall shelf and mirror

Corral clutter in its two drawers while the warm cherry frame brightens your entry hall, bedroom, or bath.



TOOL TEST

Benchtop planers

The complete skinny on these thickening machines, from which is best to a few with flaws you can live with.

Better Homes and Gardens® magazine (ISSN-0713-980X) is published seven times a year in March, May, July, September, October, November, and December/January by Meredith Corporation, 1716 Locust St., Des Moines, IA 50309-3023. Periodicals postage paid at Des Moines, Iowa, and additional mailing offices. Better Homes and Gardens trademark registered in Canada and Australia. Marca Registrada en México. One-year subscription prices: U.S. and its possessions, \$49; Canada Post Publications Mail Sales Product Agreement No. 40069223; Canadian BN 12549 2887 RT; Return undeliverable Canadian addresses to: Better Homes and Gardens WOOD magazine, PO Box, 882 5TH Ave, Markham, ON L3P 9Z3. POSTMASTER: Send address changes to Better Homes and Gardens WOOD magazine, P.O. Box 374339, Boone, IA 50037-0439.



From the company that invented versatility,
here's some more.



The all-new Multi-Max™ Oscillating Tool System.

Its fast side-to-side motion and compact design make it the perfect tool for even your most demanding remodeling projects. From cutting a door jamb to removing grout—and every job in between. It's exactly the kind of versatility you've come to expect from a Dremel tool. Call 1-800-437-3635 today for a free DVD. Or visit dremel.com to view project videos.

DREMEL®
MULTI-MAX™
Repair. Remodel. Restore.®

Available where power tools are sold.

TAKE YOUR BEST SHOT

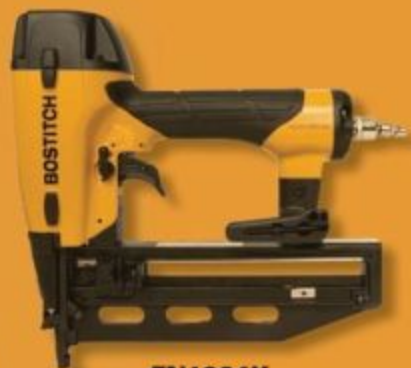

FN1664K
16 Gauge Finish Nailer



BT1855K
18 Gauge Brad Nailer



SX1838K
18 Gauge Finish Stapler

Our new oil-free finish nailers are engineered to help you achieve the level of craftsmanship you were always capable of. They offer precision-driven features such as dry-fire lockout, dial-a-depth technology, swivel fittings, patented profile tips ... even an integrated pencil sharpener.

For nearly 40 years, Stanley-Bostitch has designed its products to be the most reliable & durable pneumatic tools available. Maybe that's why more finish carpenters and serious woodworkers rely on Stanley-Bostitch products more than any other major brand*



*Based on third-party survey in U.S. and Canada asking for the brands of finish products used in the previous 12 months.

© 2009 The Stanley Works

www.bostitch.com

STANLEY

BOSTITCH[®]