

WOOD

FULL-SIZE
PATTERNS INSIDE

The World's Leading Woodworking Resource

Easy-to-Build Pergola p.34

**Only Common
Tools Needed!**



More Projects

- **Handsome Hall Bench** p.52
 - **Drill Press Cabinet** p.66
 - **Playful Kid's Clock** p.72
- and more!

**How to Cut Air-Tight
Miter's Every Time** p.49

**What You Must Know
About Treated Lumber** p.32

**Quick Kitchen-Cabinet
Upgrades** p.62





Grizzly Industrial

PURVEYORS OF FINE MACHINERY®, SINCE 1983!

- OVER A MILLION SQUARE FEET PACKED TO THE RAFTERS WITH MACHINERY & TOOLS
- 2 OVERSEAS QUALITY CONTROL OFFICES STAFFED WITH QUALIFIED GRIZZLY ENGINEERS
- HUGE PARTS FACILITY WITH OVER 1 MILLION PARTS IN STOCK AT ALL TIMES
- TRAINED SERVICE TECHNICIANS AT ALL 3 LOCATIONS
- MOST ORDERS SHIPPED THE SAME DAY • 24 HOUR ORDERING BY PHONE OR ONLINE

10" Cabinet Table Saws with Riving Knife

3 HP LEESON® MOTOR!

- Motor: 3 HP, 220V, single-phase
- Table size with extension: G0690 - 27" x 40", G0691 - 27" x 74¾"
- Blade tilt: left • Arbor: 5/8"
- Arbor speed: 4300 RPM
- Max. dado width: 1 3/16"
- Max. rip capacity: G0690 - 29½", G0691 - 50"
- Max. depth of cut: 3 1/8" @ 90°, 2 3/16" @ 45°
- Approx. shipping weight: G0690-542 lbs. G0691-572 lbs.



CAST IRON TRUNNIONS



FREE 10" CARBIDE TIPPED BLADE!

\$139 ANYWHERE IN LOWER 48 STATES

G0690 ~~\$1250.00~~
SALE \$1150.00

G0691 WITH EXTENSION RAILS ~~\$1350.00~~
SALE \$1250.00

Cyclone Dust Collector

- Motor: 1½ HP, 110V/220V, single phase, TEFC, 3450 RPM, prewired 110V
- Air suction capacity: 775 CFM
- Static pressure at rated CFM: 1.08"
- Intake port: 6" with included 5" optional port
- Impeller: 13½"
- Cartridge filter surface area: 6975 sq. in.
- Overall dimensions: 38¼" W x 23¼" D x 68½" H
- Approx. shipping weight: 210 lbs.



COLLECTION DRUM IS MOUNTED ON CASTERS FOR EASY DUST REMOVAL

THE POWER OF A 2 STAGE CYCLONE IN A NEW COMPACT SIZE!

G0703 ~~\$850.00~~ **SALE \$795.00**

\$69 ANYWHERE IN LOWER 48 STATES

10" Left Tilting Super Heavy-Duty Table Saw with Riving Knife

- Motor: 3 HP, 220V, single-phase, 3450 RPM
- Precision ground solid cast iron table
- Table size with extension wings: 40" x 27"
- Arbor: 5/8" • Max. dado width: 7/8"
- Cutting capacity: 8" L, 26" R
- Max. depth of cut: 3" @ 90°, 2 1/8" @ 45°
- Approx. shipping weight: 514 lbs.



New!

FREE 10" CARBIDE TIPPED BLADE!

SHOP FOX® CLASSIC FENCE

G1023RL

INTRODUCTORY PRICE

ONLY \$1125.00

\$89 ANYWHERE IN LOWER 48 STATES

Sliding Table & Router Attachments For G0690 & G0691 Table Saws

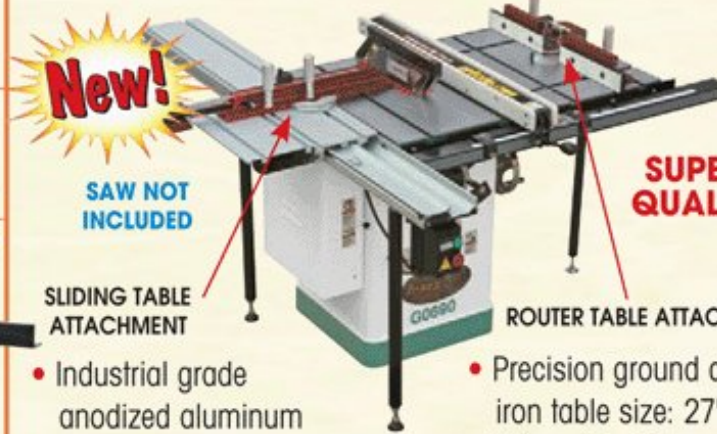

New!

SAW NOT INCLUDED

SUPERB QUALITY!

SLIDING TABLE ATTACHMENT

ROUTER TABLE ATTACHMENT

- Industrial grade anodized aluminum table size: 47" x 9"
- Telescopic anodized aluminum fence size: 30¾"-37"
- Max. cross cut: 48"
- Precision ground cast iron table size: 27" x 20"
- Unique "double cross" ¾" x 3/8" T-slots
- Universal router mount
- Table insert size: 4"

T10222 ROUTER TABLE ATTACHMENT ~~\$395.00~~ **SALE \$375.00**

T10223 SLIDING TABLE ATTACHMENT ~~\$550.00~~ **SALE \$525.00**

\$39 ANYWHERE IN LOWER 48 STATES

12" Left-Tilting Extreme Series® Table Saw with Riving Knife Feature

- Motor: 5 HP, 220V, single-phase
- Table size with extension: 30¾" x 48¾"
- Arbor speed: 3600 RPM
- Arbor: 5/8" & 1"
- Max. dado width: ¾"
- Max. rip capacity: 36"
- Max. depth of cut: 4" @ 90°, 2¾" @ 45°
- Approx. shipping weight: 756 lbs.



FEATURES DIGITAL BEVEL ANGLE READOUT INCLUDES 12" BLADE

EXTREME SERIES

G0696X ~~\$1995.00~~

SALE \$1895.00

\$169 ANYWHERE IN LOWER 48 STATES

12" Baby Drum Sander

- Sanding motor: 1½ HP, 110V, single-phase
- Conveyor motor: 1/8 HP, 110V, single-phase, variable speed 5-35 FPM
- Drum surface speed: 2127 FPM
- Max. stock dimensions: 12" wide x 3/2" thick
- Min. stock length: 8"
- Sanding drum: 4"
- Sanding belt: 3" hook & loop
- Dust collection port: 2½"
- Approx. shipping weight: 160 lbs.



G0459 ~~\$695.00~~

SALE \$525.00

\$69 ANYWHERE IN LOWER 48 STATES

17" Heavy-Duty Extreme Series® Bandsaw with Cast Iron Wheels & Trunnion

- Motor: 2 HP, 110V/220V, single-phase, TEFC
- Precision ground cast iron table size: 23 5/8" x 17 1/4"
- Table tilt: 5° left, 45° right
- Max. cutting height: 12"
- Blade size: 13 1/2" L (1/8" - 1" W)
- 2 blade speeds: 1700 & 3500 FPM
- Approx. shipping weight: 418 lbs.



MADE IN ISO 9001 FACTORY!

G0513X2 ~~\$995.00~~

SALE \$895.00

\$89 ANYWHERE IN LOWER 48 STATES

DELUXE RESAW FENCE & MITER GAUGE

EXTREME SERIES

19" Heavy-Duty Extreme Series® Bandsaw

- Motor: 3 HP, 220V, single-phase, TEFC, 1725 RPM
- Precision ground cast iron table size: 26¾" x 19"
- Table tilt: 5° L, 45° R
- Max. cutting height: 12"
- Cutting capacity/throat: 18 1/4"
- Blade size: 143" L (1/8" - 1 1/4" W)
- Blade speeds: 1700 & 3500 FPM
- Approx. shipping weight: 480 lbs.



GEARED TABLE TILT MECHANISM

HEAVY-DUTY CAST IRON FENCE & CAST IRON TABLE TRUNNIONS!

EXTREME SERIES

MADE IN ISO 9001 FACTORY!

G0514X2 ~~\$1395.00~~

SALE \$1295.00

\$89 ANYWHERE IN LOWER 48 STATES

PRICING CODE
10WOODM
MENTION THIS CODE WHEN PLACING YOUR ORDER

1-800-523-4777

3 GREAT SHOWROOMS! BELLINGHAM, WA • MUNCY, PA • SPRINGFIELD, MO

TECHNICAL SERVICE:
570-546-9663
FAX: 800-438-5901

12595



HOT SUMMER SALE

PRICES VALID MAY 17th - SEPTEMBER 25th
GO TO GRIZZLY.COM® TO SEE ALL SALE SPECIALS



6" Jointers with Mobile Base

- Motor: 1 HP, 110V or 1½ HP, 110V/220V, single-phase
- Precision ground cast iron table size: 7½" x 46"
- Max. depth of cut: ¼"
- Rabbeting capacity: ½"
- Cutterhead diameter: 2½"
- Cutterhead speed: 4800 RPM
- Approx. shipping weight: 270 lbs.

FREE SAFETY PUSH BLOCKS



BUILT IN MOBILE BASE

RACK & PINNION FENCE ADJUSTMENT

G0452 1HP MOTOR ~~\$425.00~~
SALE \$395.00

G0452Z 1½ HP WITH SPIRAL CUTTERHEAD
~~\$695.00~~ **SALE \$675.00**

\$69 ANYWHERE IN LOWER 48 STATES

8" x 76" Parallelogram Jointers

- Motor: 3 HP, 220V, single-phase, TEFC, 3450 RPM
- Precision ground cast iron table size: 8" x 76¾"
- Cutterhead speed: 5350 RPM • Cutterhead dia.: 3¾"
- Deluxe cast iron fence: 36"L x 1¼"W x 5"H
- Max. rabbeting depth: ½"
- Approx. shipping weight: 597 lbs.

G0490X SPIRAL CUTTERHEAD



BUILT IN MOBILE BASE

FREE SAFETY PUSH BLOCKS

G0490 ~~\$895.00~~ **SALE \$825.00**

G0490X WITH SPIRAL CUTTERHEAD
~~\$1195.00~~ **SALE \$1095.00**

\$139 ANYWHERE IN LOWER 48 STATES

12" x 83½" Parallelogram Jointers

- Motor: 3 HP, 220V, single-phase
- Precision ground cast iron table size: 12¾" x 83½"
- Cutterhead speed: 4950 RPM
- Max. depth of cut: ⅛"
- Max. rabbeting capacity: ¾"
- Approx. shipping weight: 1059 lbs.

PEDESTAL MOUNTED MAGNETIC SAFETY SWITCH



FREE SAFETY PUSH BLOCKS

HANDLES FOLD IN FOR ADDED SAFETY

G0609 ~~\$1895.00~~ **SALE \$1795.00**

G0609X WITH SPIRAL CUTTERHEAD
~~\$2250.00~~ **SALE \$2195.00**

\$250 ANYWHERE IN LOWER 48 STATES

15" Planer/Moulder

- Motor: 2½ HP, 110V, single-phase
- Max. cutting width: 15"
- Max. cutting height: 6"
- Min. stock thickness: ⅛"
- Min. stock length: 17"
- Max. planer cutting depth: ⅜"
- Feed rate: 11 FPM & 22 FPM
- Cutterhead dia.: 3 15/64"
- Cutterhead speed: 5500 RPM
- Cuts per minute: 11,000
- Table size: 15" x 16"
- Approx. shipping weight: 181 lbs.

CONVENIENT BUILT-IN DUST COLLECTOR!



QUICK CAM ADJUSTABLE FEED ROLLERS

G0477 ~~\$795.00~~
SALE \$725.00

\$69 ANYWHERE IN LOWER 48 STATES

15" Planer

- Motor: 3 HP, 220V, single-phase
- Max. stock thickness: 8"
- Min. stock thickness: ⅜"
- Min. stock length: 8"
- Max. cutting depth: ⅛"
- Feed rate: 16 & 30 FPM
- Cutterhead dia.: 3"
- Number of knives: 3
- Knife size: 15" x 1" x ⅛"
- Cutterhead speed: 5000 RPM
- Table size: 15" x 20"
- Approx. shipping weight: 675 lbs.

PRECISION GROUND CAST IRON BED & INFEEED OUTFEED TABLES



BUILT IN MOBILE BASE

G0453 ~~\$995.00~~
SALE \$925.00

\$139 ANYWHERE IN LOWER 48 STATES

20" Planers

- Motor: 5 HP, 220V, single-phase
- Table size: 20" x 25¾" (20" x 55½" with extension)
- Max. stock thickness: 8"
- Min. stock thickness: ⅜"
- Min. stock length: 7½"
- Max. cutting depth: ⅛"
- Cutterhead speed: 5000 RPM
- Feed rate: 16 & 20 FPM
- Approx. shipping weight: 920 lbs.

PRECISION GROUND CAST IRON BED & INFEEED OUTFEED TABLES



BUILT IN MOBILE BASE

G0454 ~~\$1495.00~~
SALE \$1395.00

G0454Z WITH SPIRAL CUTTERHEAD
~~\$2295.00~~ **SALE \$2195.00**

\$169 ANYWHERE IN LOWER 48 STATES

12 Speed Heavy-Duty 14" Floor Drill Press

- Motor: ¾ HP, 110V, single-phase
- Precision ground cast iron table
- Table size: 11¾" sq.
- Table swing: 360°
- Table tilts: 90° L & R
- Swing: 14"
- Drill chuck: ⅜" - ⅝"
- Drilling capacity: ¾" steel
- Spindle taper: MT #2
- Spindle travel: 3¼"
- Collar size: 2.595"
- Approx. shipping weight: 171 lbs.

INCLUDES BUILT-IN LIGHT (BULB NOT INCLUDED)



G7944 ~~\$325.00~~
SALE \$275.00

\$69 ANYWHERE IN LOWER 48 STATES

16" x 43" Swivel Head Wood Lathe w/Cast Iron Legs & DRO

- Motor: 2 HP, 110V, single-phase
- Precision milled cast iron bed
- Dist. between centers: 43"
- Swing over bed: 16" • Spindle bore: ⅜"
- Spindle & tailstock tapers: MT#2
- 10 speeds: 600- 2400 RPM
- Approx. shipping weight: 372 lbs.

HEADSTOCK SWIVELS FOR OUTBOARD TURNING



DIGITAL READOUT
12" TOOL REST
INCLUDES 6" FACE PLATE, CUP LIVE CENTER & SPUR CENTER

G0462 ~~\$525.00~~
SALE \$475.00

\$89 ANYWHERE IN LOWER 48 STATES

2 HP Dust Collector w/2.5 Micron Bag

- Motor: 2 HP, 220V, single-phase, 3450 RPM
- Motor amp draw: 12 Amps
- Air suction capacity: 1550 CFM
- Static pressure: 11"
- Bag capacity: 5.7 cu. ft.
- Impeller: 12¾" balanced steel, radial fin
- Height w/bags inflated 78"
- Portable base: 21¼" x 33½"
- Approx. shipping weight: 126 lbs.

FREE G3376 2 STAGE CYCLONE SEPARATOR



MADE IN ISO 9001 FACTORY!



G102922 ~~\$279.00~~
SALE \$269.95

\$69 ANYWHERE IN LOWER 48 STATES

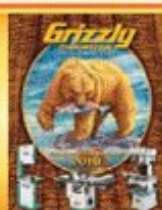

FREE
2010
FULL COLOR
CATALOG!

grizzly.com®

OVER 12,000 PRODUCTS ONLINE!



in this issue

PROJECTS

- 24 **Great Idea: Knockdown Sawhorses**
- 34 **On the Cover: Basic-Built Pergola**
Build this beautiful outdoor room with only a few common tools.
- 52 **Hall Tree Storage Bench**
Conquer clutter at the door with this easy-to-make cabinet.
- 62 **3 Efficient Kitchen Organizers**
- 66 **Drill-Press Storage Cabinet**
- 72 **Kid's Dancing Desk Clock**

SKILL BUILDERS

- 16 **Best Fixes for Loose Dadoes**
- 18 **Make Your Own Cove Molding**
- 28 **The Easy Way to Sharpen a Card Scraper**
- 42 **World's Fastest Face-Frames**
- 49 **Cut Dead-on Miters Every Time**
- 58 **Plan an Adaptable Dust-Collection System**

TOOLS & MATERIALS

- 22 **Straight vs. Spiral Router Bits**
- 30 **Wise Buys: Portable Miter Saw Stands**
- 32 **Tips for Working with Treated Lumber**
- 76 **Shop Test: Compact Power Drivers**
- 86 **Shop-Proven Products**
Riving-knife contractor saw, low-dough miter gauge, and more.

DEPARTMENTS

- 6 **Sounding Board**
- 8 **Shop Tips**
- 80 **Ask WOOD**
- 92 **What's Ahead**



32



72

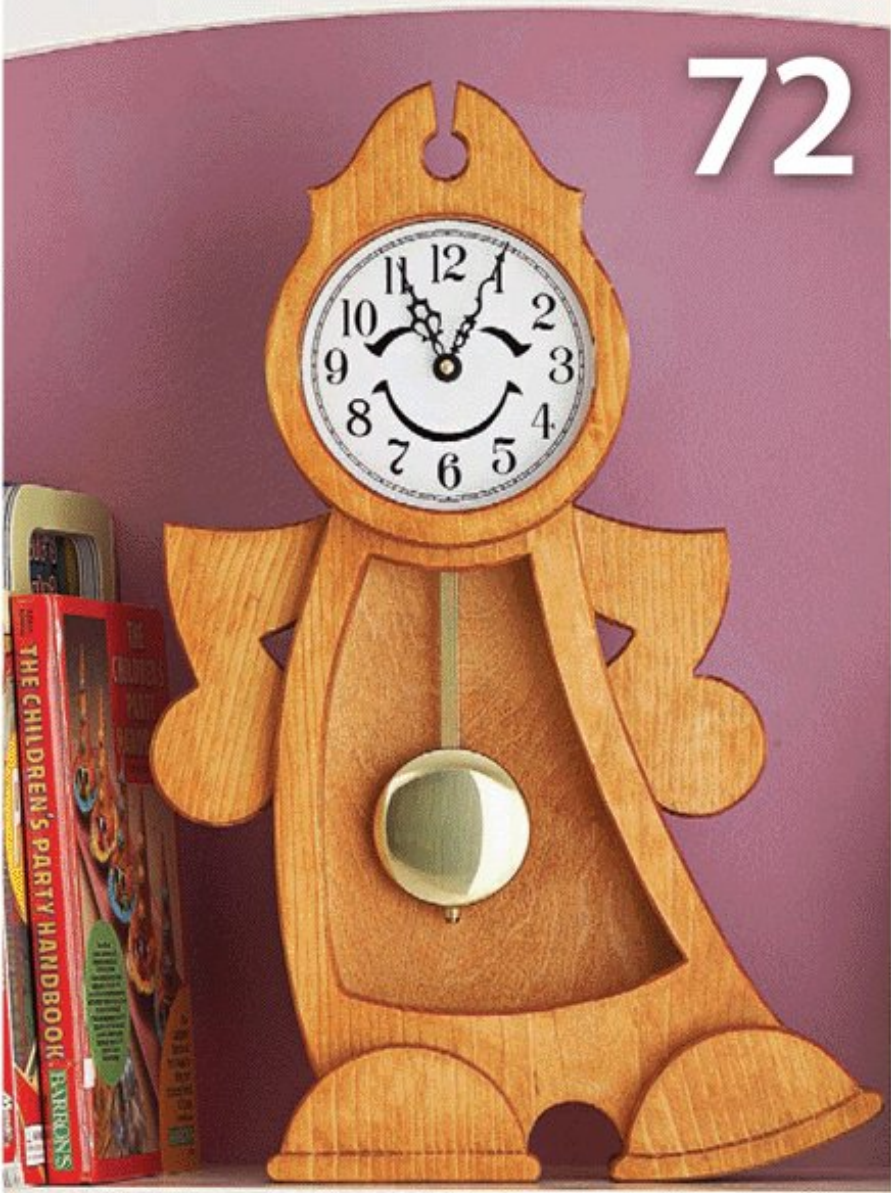

This seal is your assurance that we build every project, verify every fact, and test every reviewed tool in our workshop to guarantee your success and complete satisfaction.



18



49



on the web

woodmagazine.com

STAY SHARP WITH WOOD'S E-NEWSLETTER

Keep up-to-date on the latest tool news, learn from your fellow woodworkers, and get a FREE PLAN in every issue of *WOOD* magazine's weekly E-newsletter. And we promise not to fill your e-mailbox with sales pitches. Subscribe today at woodmagazine.com/enews.

25 YEARS ON ONE DVD

Readers told us they wanted the complete *WOOD* magazine digital archive on a single DVD, and we obliged. Search faster and still enjoy the highest-quality digital back issues in the business. Get it now at woodmagazine.com/DVDlibrary.

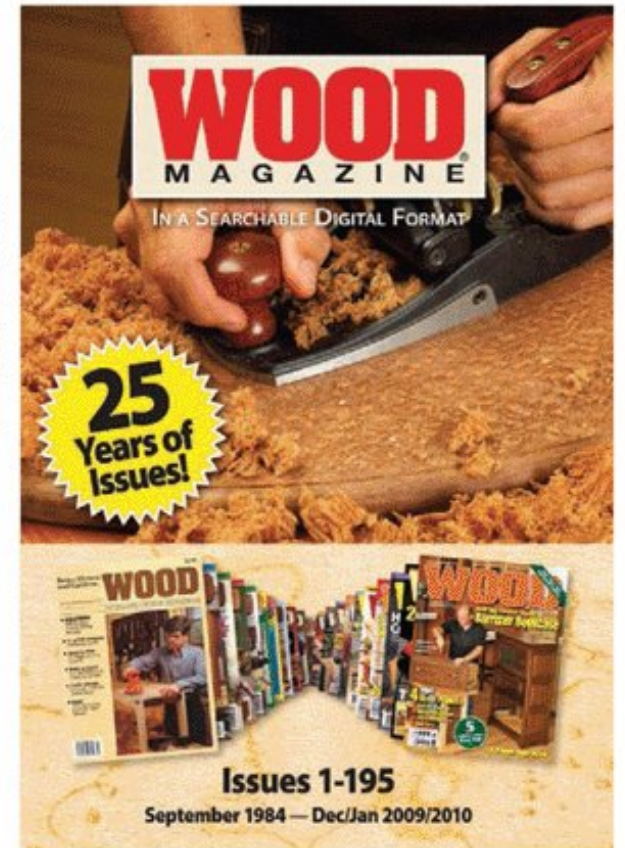

WIN POWER TOOLS!

Why spend your money on woodworking tools and supplies when you can get them free? Our tool sweepstakes are legendary on the Web, so get your share by signing up at woodmagazine.com/promotions.

BONUS SCREEN PLAN: GO ONLINE



To complement the Basic-Built Pergola on page 34, you'll find FREE plans for this matching Privacy Screen/Trellis at woodmagazine.com/screen. It features the same simple construction techniques as the Pergola.

LOOK BEFORE YOU BUY

With more tool reviews online than ever, do your research at woodmagazine.com/reviews to make sure you get the most bang, buzz, and whirl for your tool-buying buck.

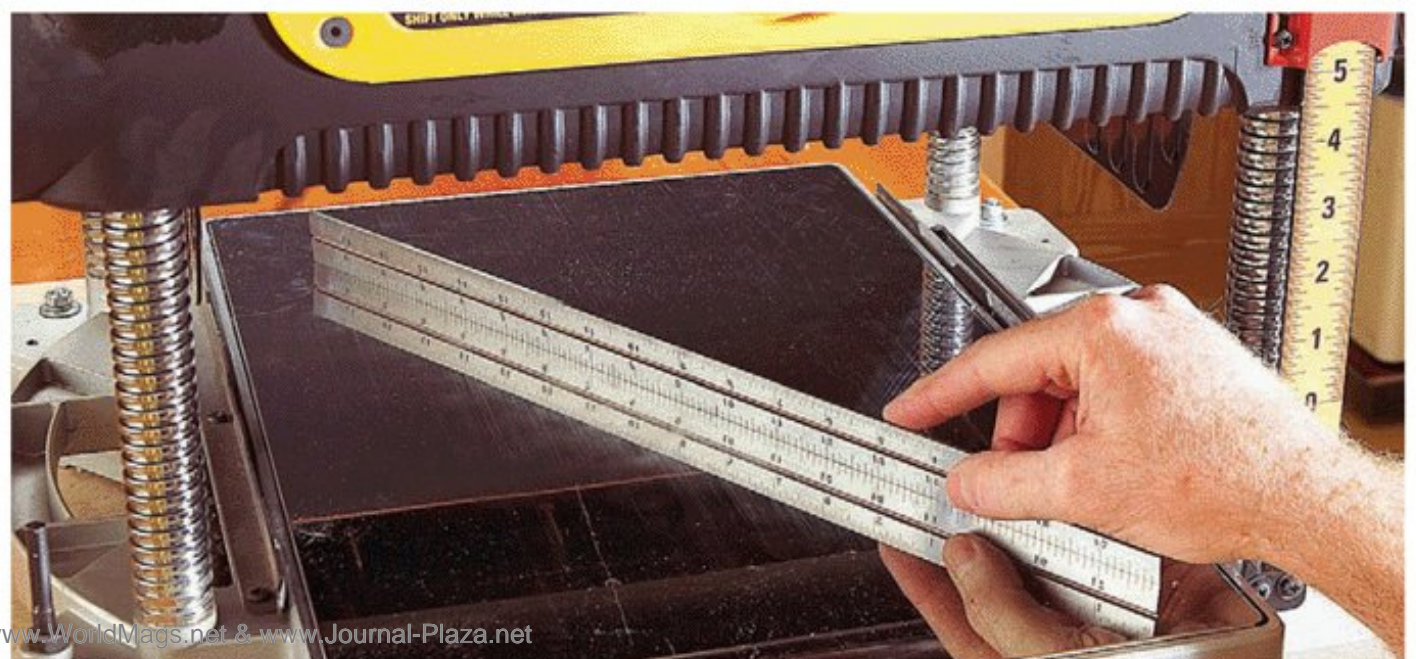

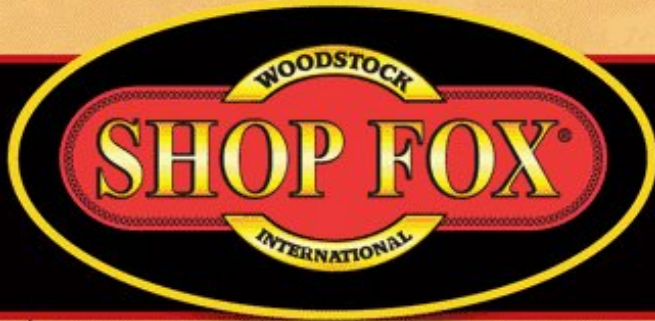

INNOVATIVE PRODUCTS SINCE 1989!



SHOP FOX® machines are backed by a 2 Year Warranty!

12" TABLE SAW

with Riving Knife & Extension Table

- 5 HP, 220V, single-phase motor
- Precision ground cast iron table size: 30¾" x 78¾"
- Arbor size: 1" • Arbor speed: 3600 RPM
- Blade tilt: left • Max. rip capacity: 52"
- Max. depth of cut: 4" @ 90°, 2¾" @ 45°



Cast Iron Trunnions

W1761 5 HP, 12" Table Saw

VARIABLE SPEED PLANER/MOULDER with STAND

- Motor: 2 HP, 220V, single-phase
- Precision ground cast iron table & wings
- Table size with wings: 36¼"L x 10"W
- Max. cutting width: 7"
- Max. planing height: 7½"
- Max. planing depth: ½"
- Max. moulding depth: ¾"
- Knife size: 7⅞" x 1½" x ¼" HSS
- Cutterhead speed: 7000 RPM
- 4" dust port
- Rubberized steel feed rollers
- Approx. shipping weight: 330 lbs.

We also carry an extensive selection of moulding knives for this machine!

PATENTED

Precision Ground Cast Iron Table

Heavy-Duty Cabinet Stand

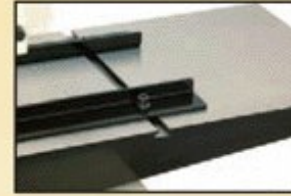

Table Wings Have T-slots for Easy Guide Rail Adjustment

W1812

Planer/Moulder



8" JOINTER

with Parallelogram Adjustable Beds

- 3 HP, 220V, single-phase, TEFC motor
- Precision ground cast iron parallelogram design table measures 8" x 76⅝"
- 4 knife, 5350 RPM cutterhead
- Large center mounted cast iron fence
- Rabbeting capacity: ⅝"



Built-in Mobile Base

W1741 8" Jointer

SPIRAL CUTTERHEAD PLANERS

with Built-in Mobile Base

- 3 HP or 5 HP, 220V, single-phase motor
- Precision ground cast iron table & extension wings
- 2 speed gear box
- 2 adjustable bed rollers
- German-made carbide insert spiral cutterhead
- Pedestal mounted thermal overload magnetic safety switch
- Built-in locking mobile base

W1742S 15" Planer
W1754S 20" Planer



10" SLIDING TABLE SAW

with Scoring Blade & Riving Knife

- 5 HP, 220V, single-phase, TEFC motor
- Table size with extension wings: 40" W x 47" L
- Sliding table size: 12¼" W x 63" L
- Scoring blade diameter: 3⅞"
- Scoring blade arbor speed: 8,000 RPM
- Main blade arbor speed: 4,000 RPM
- Single lever locking fence



W1811 10" Sliding Table Saw

OUTSTANDING SHOP FOX® ACCESSORIES

ADJUSTABLE MOBILE BASES

STRONGER FRAME WITH IMPROVED WHEELS AND GUSSETED SUPPORTS!

D2260A Mini Mobile Base
600 lb. capacity

D2057A Heavy-Duty Mobile Base
700 lb. capacity

D2058A Super Heavy-Duty Mobile Base
1300 lb. capacity

D2259A Extension Kit (fits all models)

D2246A 36" Extension Bars (fits all models)

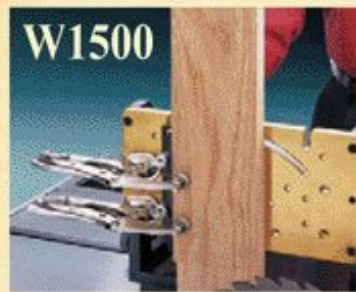
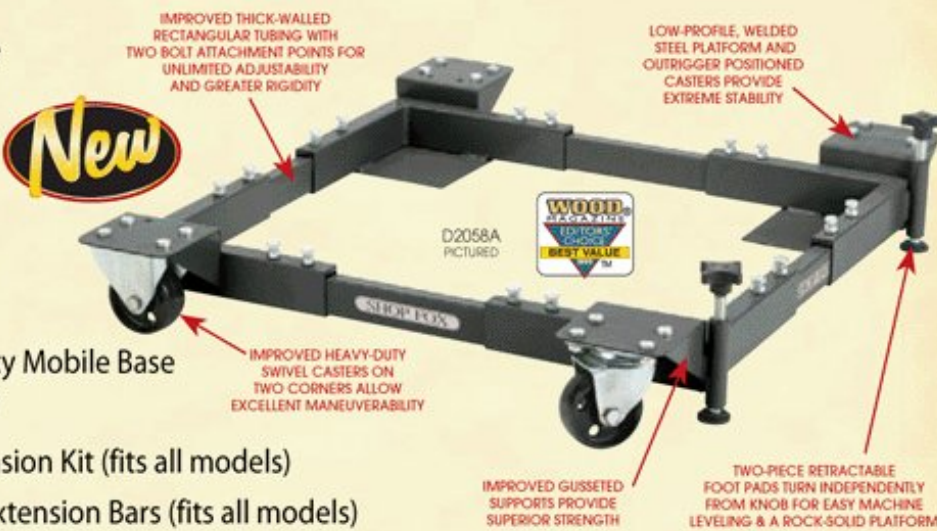

RIGHT ANGLE JIG

Cut tenons, dados, rail ends and finger joints safely & with complete accuracy. The **SHOP FOX®** Right Angle Jig is constructed using top quality aluminum castings & plates which are machined to exacting tolerances.

- Solid aluminum
- Extended depth: 13"
- Closed depth: 7½"
- Height: 8"
- Max. horiz. opening: 1¾" x 8"



ADJUSTABLE ROLLER STAND

- Stand length is adjustable from 19½" to 54"
- Number of rollers: 9
- Stand height adjusts from 24½" to 38"
- Roller diameter: 2"
- Two-way locking swivel casters: 4¼" diameter
- 300 lb. capacity

WOODSTOCK® INTERNATIONAL IS ALSO HOME TO THESE OTHER FINE BRANDS:

STEELEX®, PRO-STICK®, PLANER PAL®, JOINTER PAL®, BOARD BUDDIES®, PARROT VISE®, ROMAN CARBIDE® ROUTER BITS AND SHAPER CUTTERS.

VISIT OUR WEBSITE OR CALL TOLL FREE TO FIND AN AUTHORIZED DEALER NEAR YOU.

SHOPFOX.BIZ

sales@shopfox.biz

WHOLESALE ONLY



1-800-840-8420

SHOP FOX® is a registered trademark of Woodstock International, Inc.

Better Homes and Gardens®
WOOD

woodmagazine.com

July 2010

Vol. 27, No. 3

Issue No. 198



Lucas constructed this jewelry chest (issue 191) for his wife.

**EDITOR-IN-CHIEF
BILL KRIER**

Managing Editor
MARLEN KEMMET

Art Director
KARL EHLERS

Techniques Editor
BOB WILSON

Multimedia Editor
LUCAS PETERS

Design Editor
JEFF MERTZ

Production/Office Manager
MARGARET CLOSNER

Deputy Editor
DAVE CAMPBELL

Senior Design Editor
KEVIN BOYLE

Tool & Techniques Editor
BOB HUNTER

Multimedia Editor
CRAIG RUEGSEGGER

Associate Art Director
GREG SELLERS

Administrative Assistant
SHERYL MUNYON

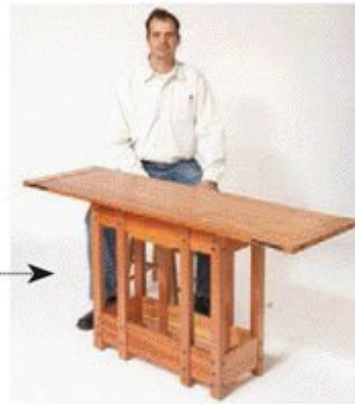

Kevin built this Greene and Greene reproduction server out of mahogany with ebony plugs and splines.

Photographers **JASON DONNELLY, SCOTT LITTLE, JAY WILDE**
Contributing Illustrators **TIM CAHILL, LORNA JOHNSON, ROXANNE LeMOINE**
Technical Consultants **BOB BAKER, DOUG HICKS**
Contributing Craftsman **JIM HEAVEY**
Contributing Proofreaders **BABS KLEIN, IRA LACHER, JIM SANDERS**

Publisher **MARK L. HAGEN**

ADVERTISING AND MARKETING

CHICAGO: 333 N. Michigan Ave., Suite 1500, Chicago, IL 60601

Marketing Manager **AMANDA SALHOOT**

Advertising Manager **JACK CHRISTIANSEN**

Direct Response Advertising Representative **LISA GREENWOOD**

Assistant **KEVIN BARRY**

ATLANTA: Navigate Media

DETROIT: RPM Associates

Business Manager **JEFF STILES**

Consumer Marketing Director **TODD BIERLE**

Production Manager **SANDY WILLIAMS**

Advertising Operations Manager **JIM NELSON**

E-Commerce Manager **MATT SNYDER**

Vice President/Group Publisher **TOM DAVIS**

MEREDITH NATIONAL MEDIA GROUP

President **JACK GRIFFIN**

EXECUTIVE VICE PRESIDENTS

President of Consumer Magazines **TOM HARTY**

Chief Brand Officer **ANDY SAREYAN**

Special Interest Media **DOUG OLSON**

President, Meredith Integrated Marketing **MARTIN F. REIDY**

SENIOR VICE PRESIDENTS

Corporate Marketing Officer **NANCY WEBER**

Consumer Marketing **DAVID BALL**

Corporate Sales **MICHAEL BROWNSTEIN**

Editorial Director, Des Moines **GAYLE GOODSON BUTLER**

Editorial Director, New York **SALLY LEE**

Finance **MIKE RIGGS**

Meredith 360° **JEANNINE SHAO COLLINS**

Meredith Women's Network **LAUREN WIENER**

VICE PRESIDENTS

Direct Response & Travel **PATTI FOLLO**

New Media & Marketing Services **ANDY WILSON**

Newsstand **DAVID ALGIRE**

Production **BRUCE HESTON**

Research Solutions **BRITTA WARE**



Chairman and Chief Executive Officer **STEPHEN M. LACY**

Vice Chairman **MELL MEREDITH FRAZIER**

In Memoriam — **E.T. Meredith III (1933-2003)**

Our subscribers list is occasionally made available to carefully selected firms whose products may be of interest to you. If you prefer not to receive information from these companies by mail or by phone, please let us know. Send your request along with your mailing label to Magazine Customer Service, P.O. Box 37452, Boone, IA 50037-0452.

© Copyright Meredith Corporation 2010. All rights reserved. Printed in the U.S.A.
Retail Sales: Retailers can order copies of WOOD for resale by e-mailing jennifer.buser@meredith.com

SUBSCRIBER SERVICE

Go to woodmagazine.com/help or write to WOOD magazine, P.O. Box 37439, Boone, IA 50037-0439



woodmagazine.com

5

www.WorldMags.net & www.Journal-Plaza.net

**STRONG
BOND**
WITH LESS CLAMP TIME.

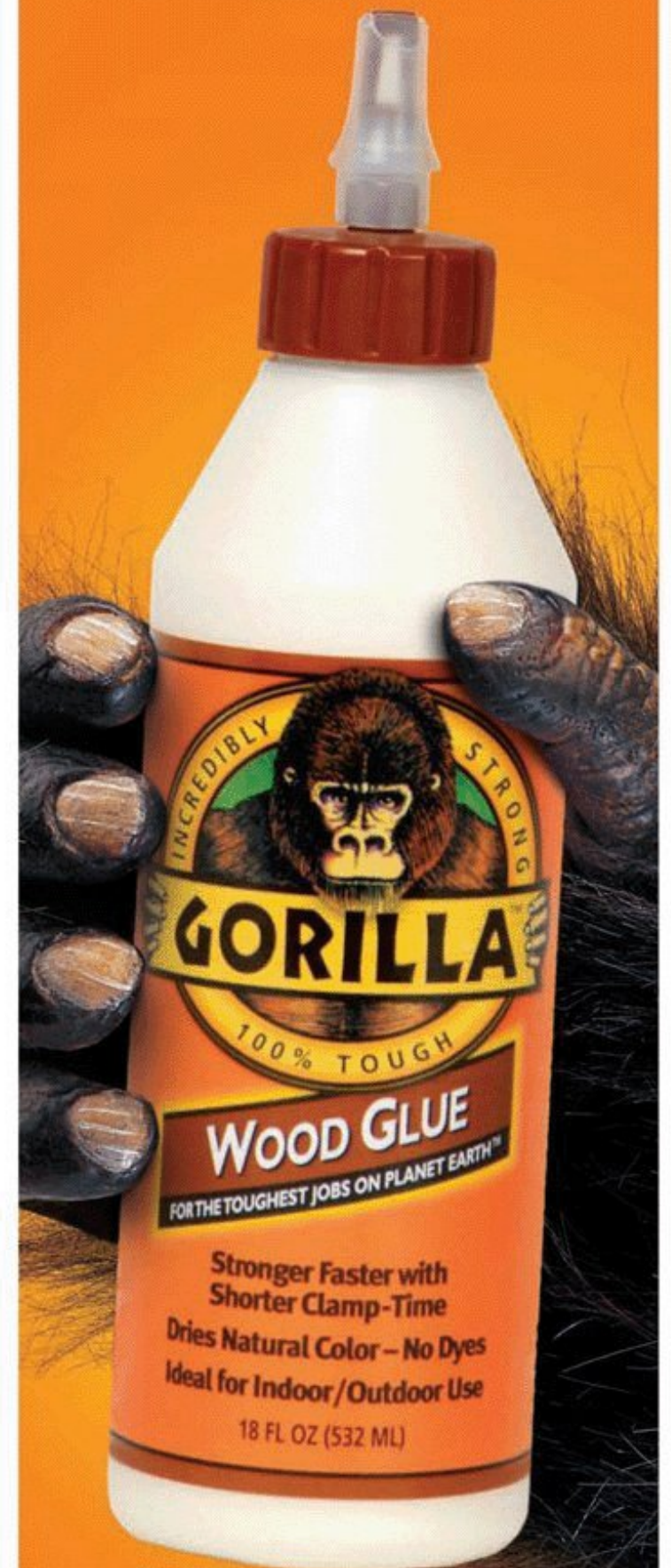

High strength with a shorter clamp time along with no dyes for a natural finish makes Gorilla Wood Glue ideal for your woodworking and building projects.

FOR THE TOUGHEST JOBS ON PLANET EARTH.®

GORILLATOUGH.COM

1-800-966-3458 Made in U.S.A.

© 2009 Gorilla Glue Company

Sounding Board

Our bulletin board for letters, comments, and timely updates

Machinist dad has the "metal" to build an excavator

While looking through issue 194 (November 2009) of *WOOD*® magazine recently, my 4-year-old son spied the toy excavator on page 62 and asked me to make it for him. I'm a fledgling woodworker with a limited set of tools. But I am a welder and metal fabricator by trade, so I decided to make the excavator from aluminum.

I made a few dimensional changes to accommodate stock I had on hand, and used machine screws for the joinery. After fabricating the parts I buffed each surface to a mirror shine. It took about 50 hours to complete, but it was worth it when I saw my son's face on Christmas morning upon opening this gift.

—Doug Savery, Middlefield, Mass.

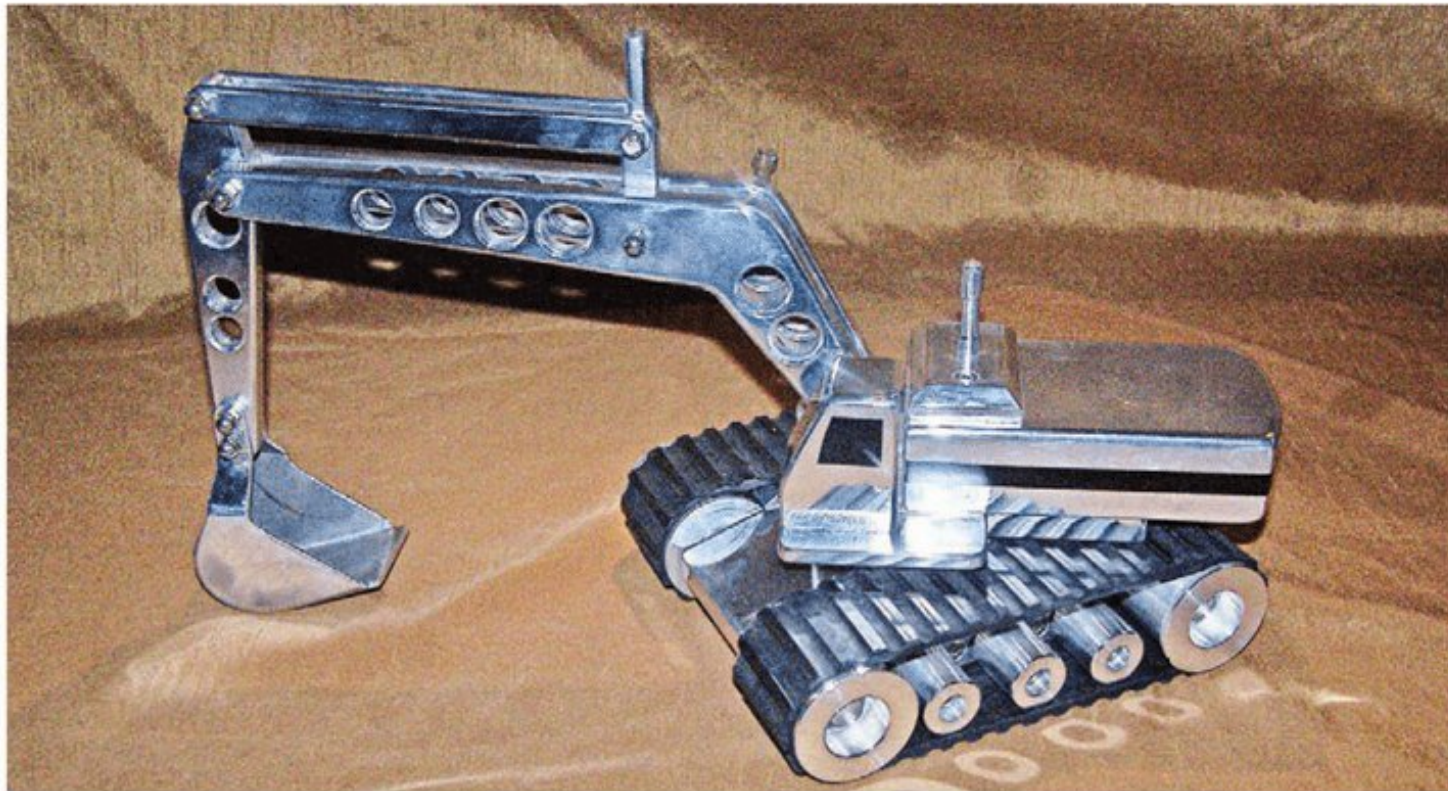

Article inspires reader to tackle cabinets

Thank you for the article "Make Cabinets the Easy Way" in issue 191 (July 2009). Reading it gave me the understanding and confidence to make cabinets for my family room. I made the face-frame cabinets from hard maple and maple-veneered plywood, using overlay doors and drawer fronts, and bottom-mount slides for the drawers. The base-cabinet assembly measures 25' long, 25" deep, and 36" tall, with a bookcase on one end.

Although it took longer than I expected, I'm thrilled with the outcome of my first major woodworking endeavor. Next on my to-do list is learning to make raised-panel doors, so I can make cabinets in that style for my kitchen.

—Len May, Crystal Lake, Ill.

Article update Issue 195 (Dec./Jan. 2009/2010)

■ For the Mortising/Doweling Jig on page 55, the screw holes used to mount the aluminum bars to the wood guides must be countersunk into the bars, as shown at right, to sit flush below the surface of the acrylic top.

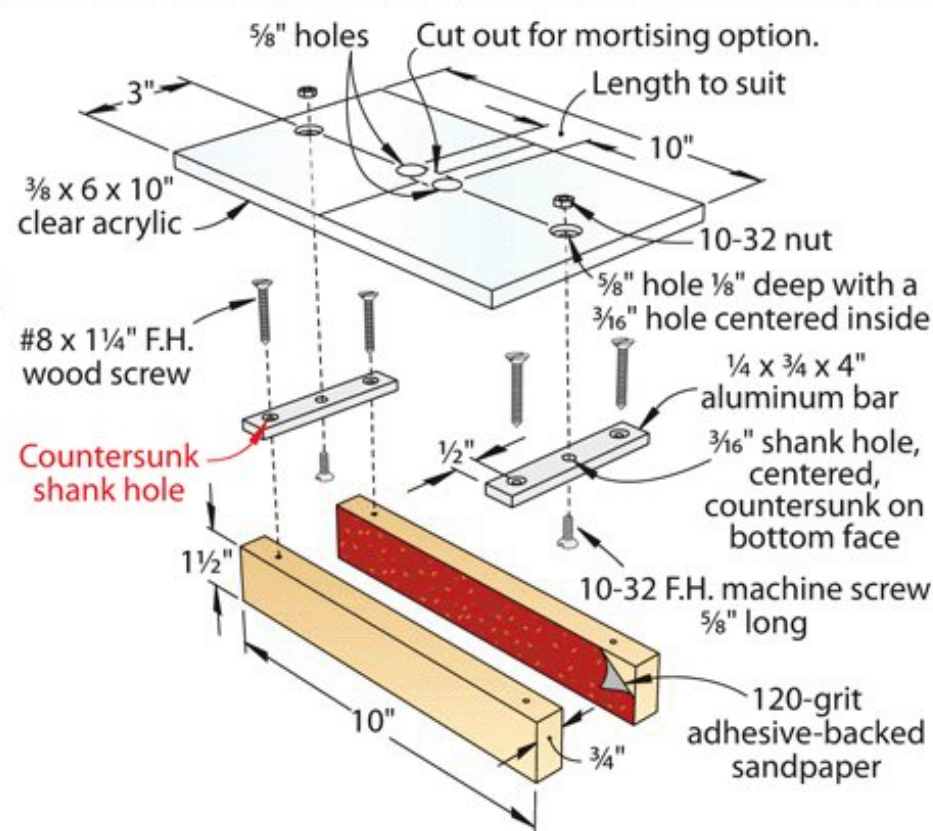

Article update Issue 197 (May 2010)

■ In the review of cabinet tablesaws on page 49, the dust hose, support arm, and mounting hardware for SawStop's Professional saw do not come with the saw. The optional kit sells for \$199.

HOW TO REACH US

■ For woodworking advice:

Post your woodworking questions (joinery, finishing, tools, turning, dust collection, etc.) on one of our online forums at woodmagazine.com/forums.

■ To contact our editors:

Send your comments via e-mail to woodmail@woodmagazine.com; or write to *WOOD* magazine, 1716 Locust St., LS-221, Des Moines, IA 50309.

■ Subscription assistance:

To notify us of an address change or to get help with your subscription, visit woodmagazine.com/service. Or write to *WOOD* magazine, P.O. Box 37439, Boone, IA 50037-0439. Please enclose your address label from a recent magazine issue.

■ To find past articles:

See our index at woodmagazine.com/index.

■ To order past issues and articles:

For past issues of *WOOD* magazine, our special issues, or downloadable articles, visit our online store at woodmagazine.com/store. Some issues are sold out.

■ Updates to previously published projects:

For an up-to-date listing of changes in dimensions and buying-guide sources from issue 1 through today, go to woodmagazine.com/editorial.

SKIL
Do it right. Do it with Skil.™

**Precision is
where we draw the line.**



**The SKIL 12" Compound Miter Saw with
laser cut line ensures the right cut every time.**

Your confidence has you ready to take on even the most complex projects around the house. That's why we engineered the SKIL 12" Compound Miter Saw. Patented laser cut line for perfect cuts. Left/right extension rails for better control. Nine positive stops for pinpoint accuracy. And the **highest-rated motor in the industry**. It's not just the best saw for the money, it's the only saw at this price with so many advanced features. After all, you draw the line on precision, too.



AVAILABLE AT

LOWE'S
Let's Build Something Together™

skiltools.com

CORDLESS TOOLS CORDED TOOLS BENCHTOP TOOLS

Shop Tips

Helping you work faster, smarter, and safer

The less dusty dust-Tee

Bruce Wrenn has made a habit of fixing up used tools for the Apex, N.C., shop that houses his home-maintenance business. When he turned his attention to improving the dust collection on his three 14" bandsaws, "the only word to describe the results is WOW!" Bruce says. Here's how you can do the same with your bandsaw.

Using PVC glue, attach a 4" length of PVC pipe to one arm of a PVC Tee, as shown. Cut two strips of 1/8" x 1" x 8" flat steel and drill slots to accept the trunnion bolts on the bottom of your bandsaw table, as shown. Then drill holes to attach two blast-gate brackets (Rockler, item no. 26813, \$4 each, 800-279-441, rockler.com). Mount the brackets to the strips using the included bolts. Then, after loosening the trunnion bolts, slide the steel brackets in place on them. (You may have to use washers to shim the steel strips flush with the ribs on the bottom of your bandsaw table.)

Attach the Tee to the blast gate brackets with hose clamps, pointing the Tee leg toward the blade. Use a butter tub lid or a PVC slip cap to seal one end of the tee and attach your dust collection hose to the other. With your dust collector on, any dust that falls through the table gets sucked into the tee.



Bruce's shop-cleansing Top Shop Tip earns him Festool's T12+3 lithium-ion cordless drill set. Congrats, Bruce!



Top Shop Tip

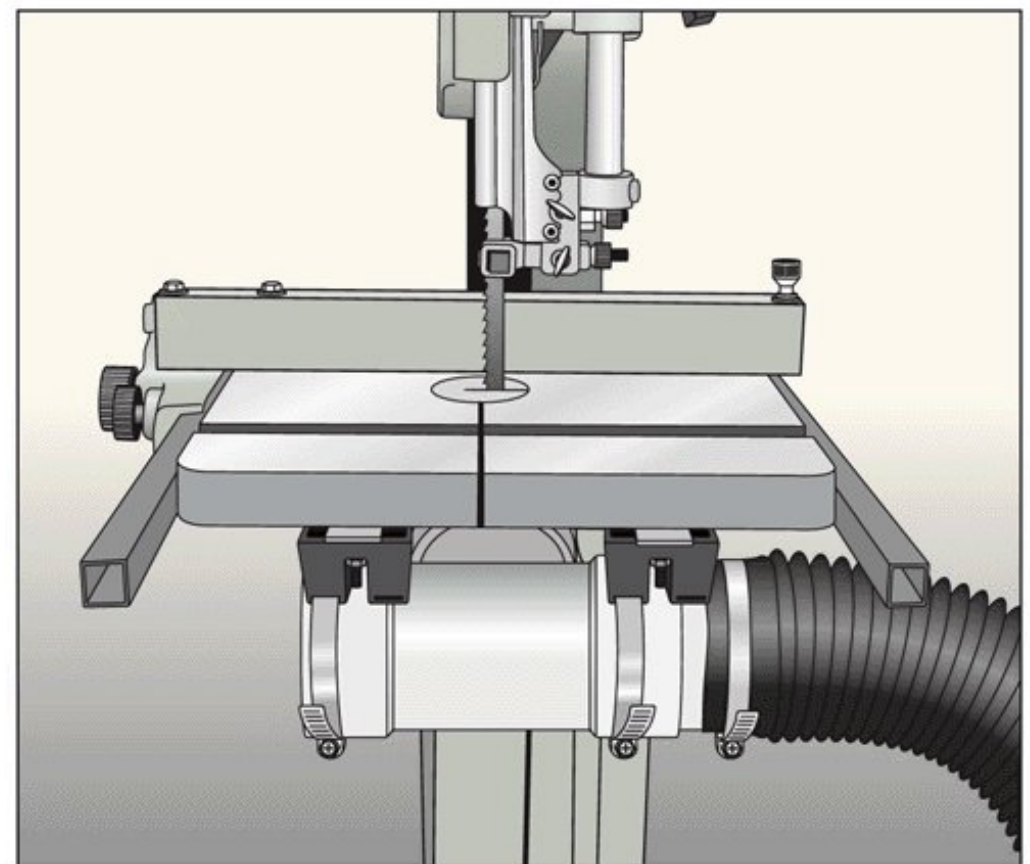
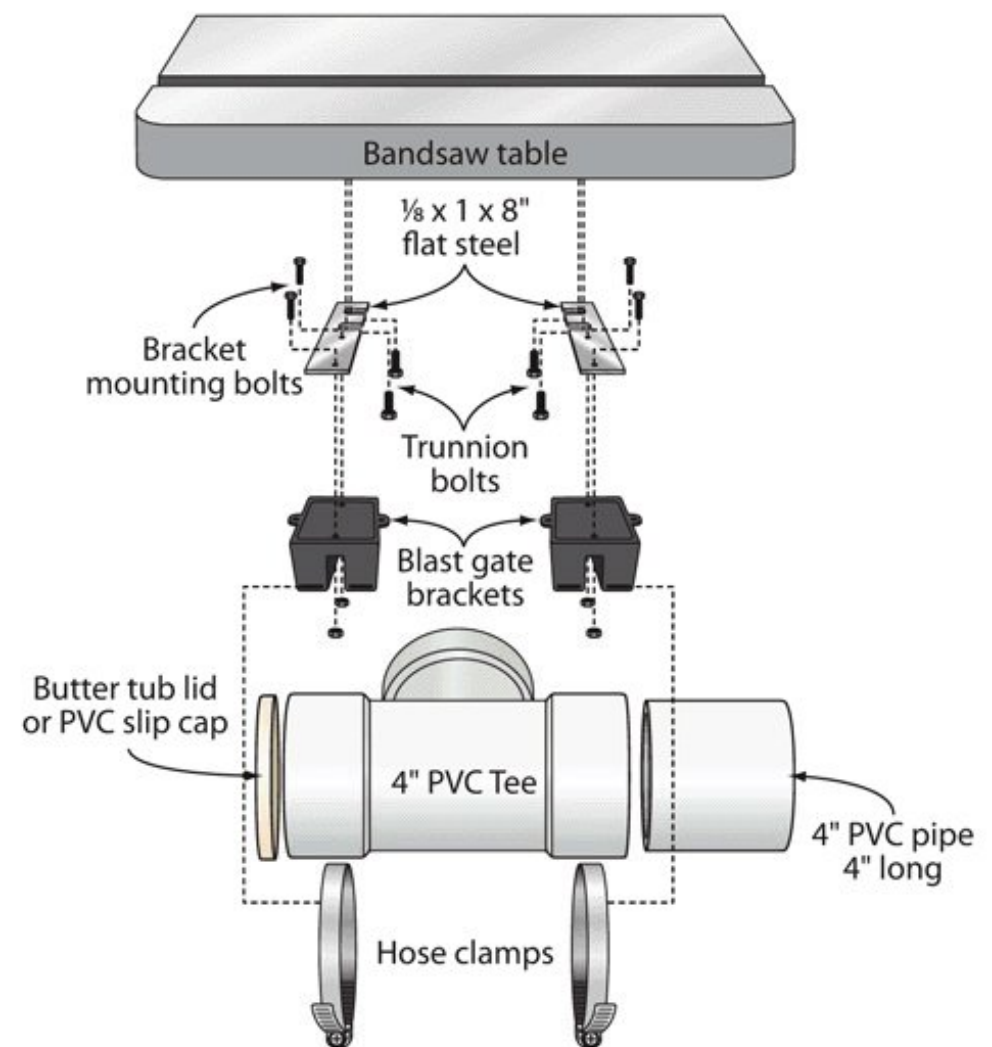

continued on page 10

Your tips earn cash, tools!

Tell us how you've solved a workshop stumper. If we print it, you'll get \$100 and a copy of *450+ Best-Ever Shop Tips* (woodmagazine.com/450tips). And, if your idea garners Top Shop Tip honors, we'll also reward you with a tool prize worth at least \$300.

Send your best ideas, along with photos or drawings and your daytime phone number, to: **Shop Tips, WOOD Magazine, 1716 Locust St., LS-221, Des Moines, IA 50309-3023.**

Or, by e-mail: shoptips@woodmagazine.com. Include your contact info in the e-mail.

Because we try to publish original tips, please send your tips only to WOOD® magazine. Sorry, submitted materials can't be returned.



The quickest, easiest way to find the best woodworking ideas and projects

**25 Years of
WOOD Magazine
(195 issues!)**



**Now on a single
high-capacity
DVD-ROM disc!**

Readers told us they wanted all 195 back issues on one disc, with a single, comprehensive, searchable index. So we did just that, while maintaining the super-high-quality, 300-dpi resolution, ensuring you crystal-clear illustrations and photos.

DVD features:

The user-friendly index of all back issues makes it easy to find any project plan, shop tip, or skill-builder from this huge archive. Click on the indexed article and go to it instantly! Or browse through the issues using the prominent bookmarks, linked covers, and table of contents. There, too, one click takes you to the information you need.

High resolution PDFs make for easy, enjoyable reading. View every photo, drawing, and detail in digitally reproduced, crystal clarity. Zoom in for a closer look, or print articles for use in the shop with the handy "Print this article" button.

Free up shelf space in your home and shop: The disc and protective case fits 195 issues into the space of a slim paperback.

Save hundreds of dollars versus buying back issues. In fact, many of the most sought-after issues on this disc have been out of print for years and are no longer available in any other format.

Compatible with PC and Mac. If you don't already have it, Adobe Reader is included on the disc for viewing.

Where else will you find more than...

295 Furniture Projects

525 Tool Reviews and Features

230 Shop Projects

1,515 Shop Tips

900 Weekend Projects

765 Skill-building Techniques

Order online at woodmagazine.com/DVDlibrary or by phone at **888-636-4478**

AD WD0710

For the **ultimate** in **dust collection**, harness the **power** of a **cyclone**.

The Dust Deputy's cyclonic action eliminates clogged filters which greatly enhances vacuum performance.

Dust – from woodworking or any source – has always been a problem. But now you can remove over 99% of dust before it ever has a chance to clog your vacuum filter. Our award-winning Dust Deputy retrofits on any shop vac, works wet or dry, and will do wonders to improve your air quality and reduce cleanup time.

 Made in USA

Order Online at **oneida-air.com**

Call for your FREE catalog!
800.732.4065



U.S. Pat. #7,282,074
E.U. Pat. Pend.

Oneida
Air Systems
800-732-4065
www.oneida-air.com

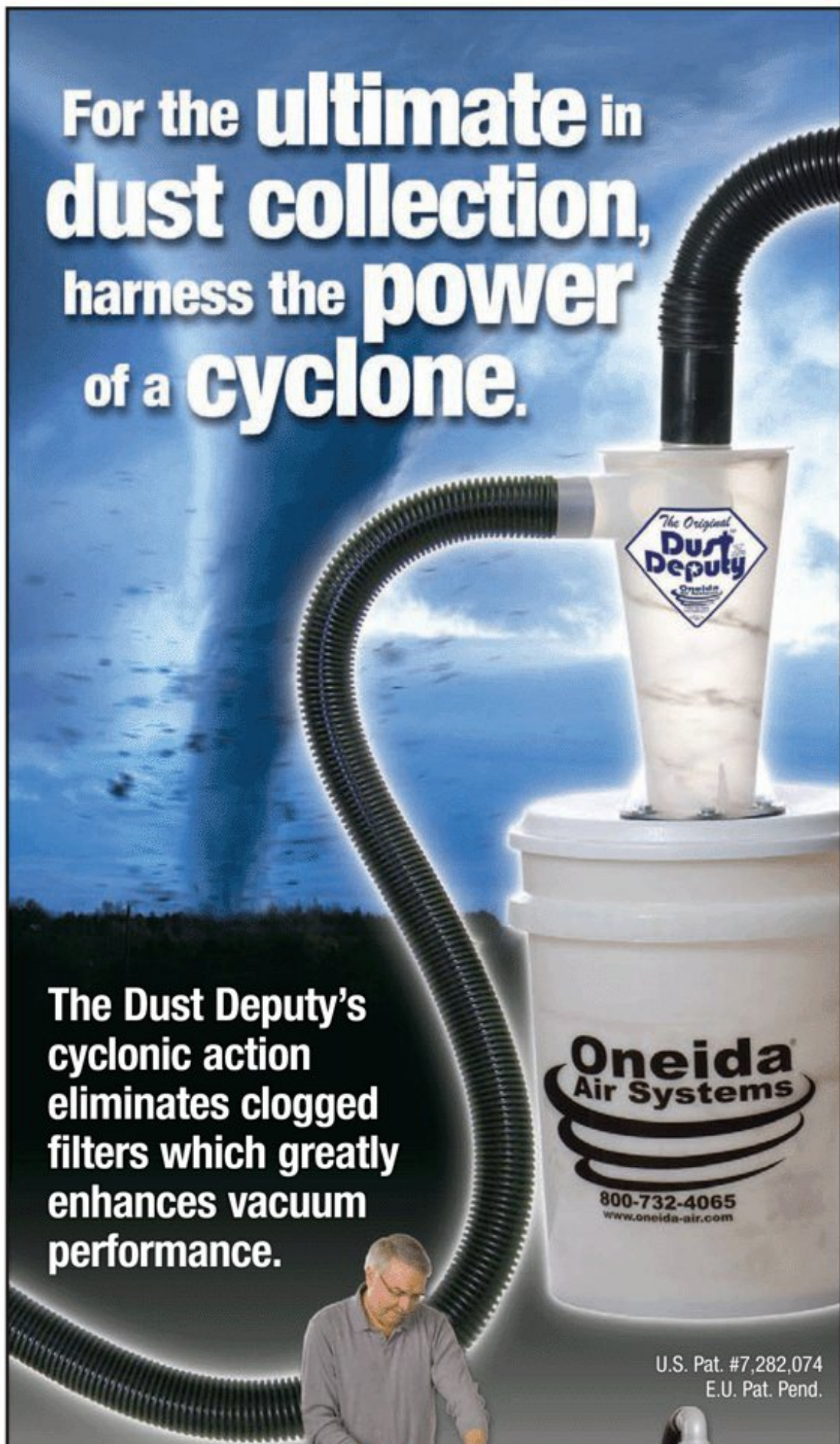

Shop Tips

Twice the pushstick, twice the control

I feel safer performing tablesaw rip cuts with this double pushstick that I came up with—two pushsticks connected with a 1 1/4" dowel, 2" long. (See the *WOOD Patterns®* insert, page 45, for the pushstick pattern.) It allows me to cut narrower pieces without getting my fingers close to either side of the spinning blade. Plus, it straddles my blade guard, giving me one more incentive to leave the guard on the saw.

—Ken Peters, Spring Hill, Fla.

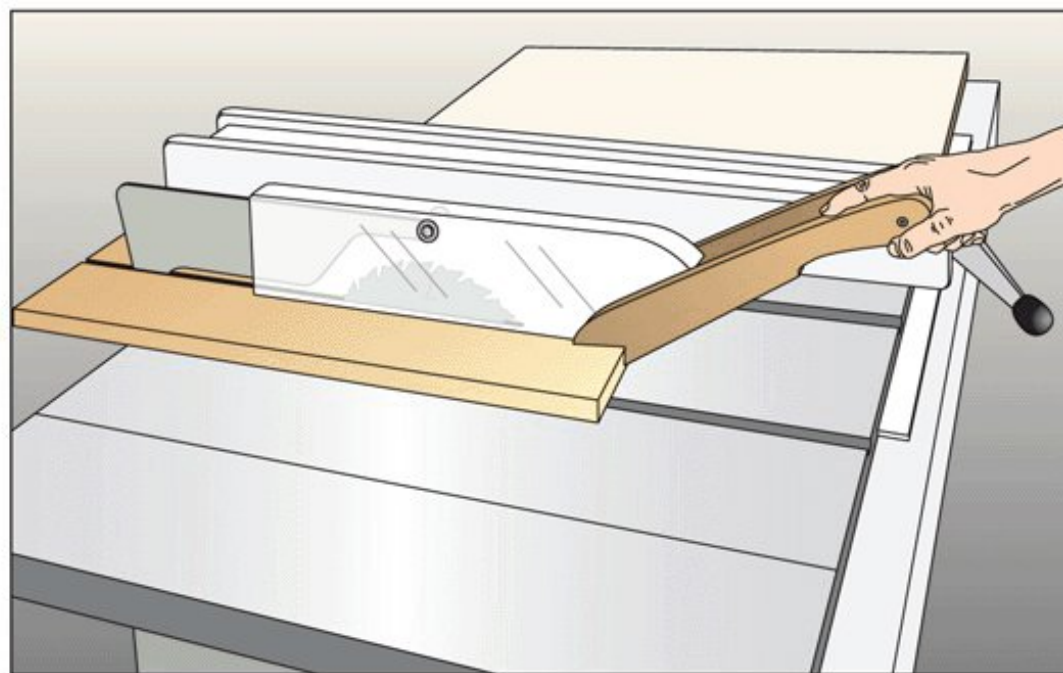
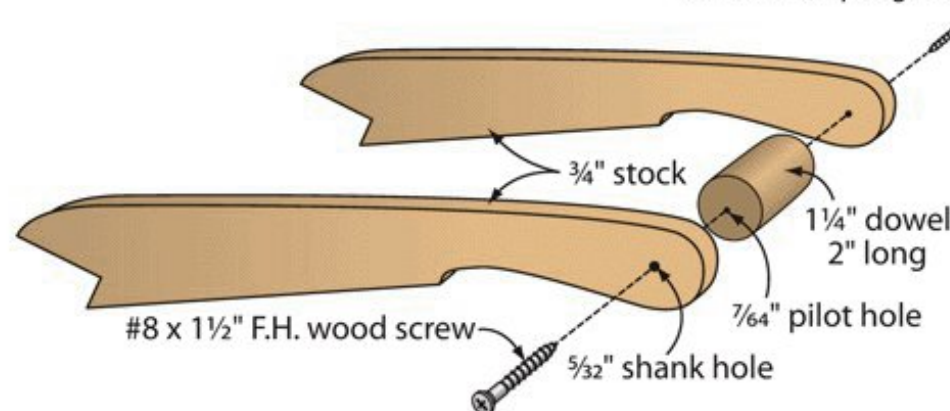

Accessorize your glue-ups with a leather belt

To prevent clamp-jaw mars in an otherwise perfect project, crosscut an old leather belt with a utility knife. Use the short, leather strips as wraparound, one-piece clamp pads, as shown.

—Jack Reynolds, Boynton Beach, Fla.

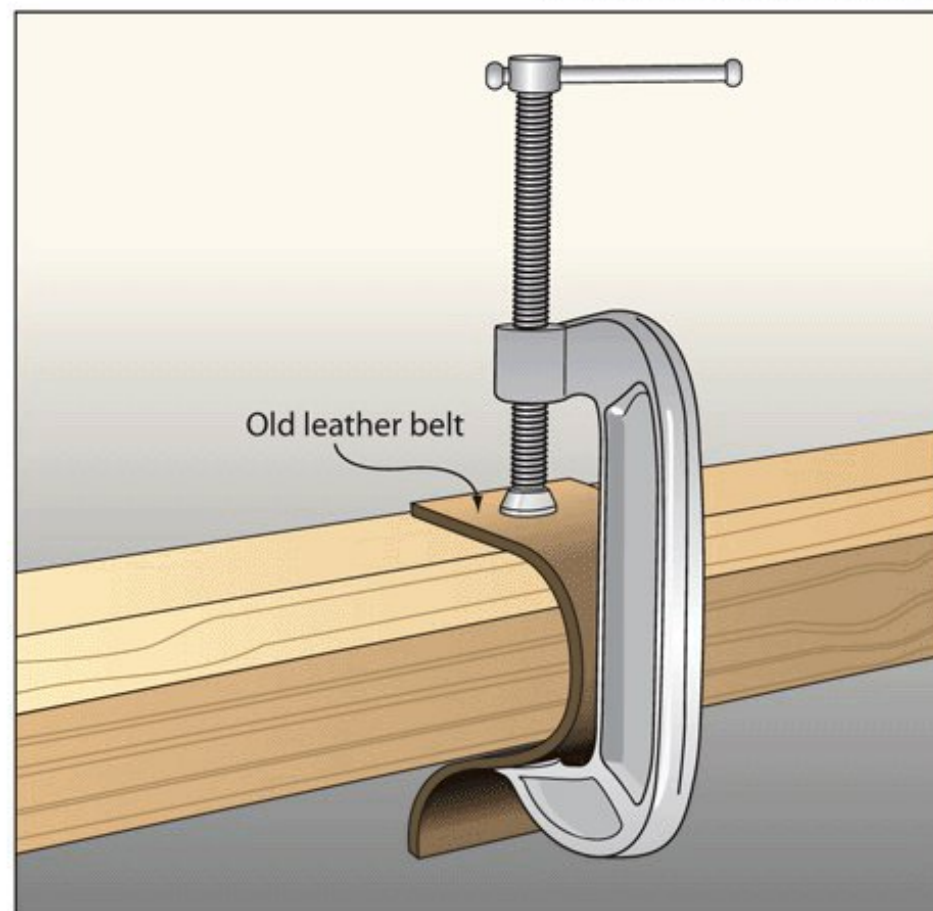

"Dowel-evator" makes even short ones accessible

The tall, narrow box I used to contain my wooden dowels frustrated me because I'd have to dump the entire box to get at the shorter ones. So I came up with the Dowel-evator, shown *below*.

To make one, cut a 4" piece of PVC 32" long. Bevel the top end, as shown, for easy access. Drill three or four $\frac{1}{8}$ " holes around the bottom for the $\#8 \times \frac{3}{4}$ " panhead screws that will act as stops for the lift block. Next drill a $\frac{3}{16}$ " hole on the back top of the pipe for wall mounting. Then drill a $\frac{1}{4}$ " hole on the front of the pipe, near the top, and epoxy a #0 grommet (find it at your hardware store) from the inside.

From a scrap of 2x6, cut a disc just under 4" in diameter, sanding if necessary, until it slides easily in the pipe. Then thread a small screw eye into the center of the disc and tie a 40" length of $\frac{1}{16}$ " polyester cord to the screw eye. Make a knot about 8" above the screw eye and thread a washer onto the draw cord to limit the travel of the lift block.

Finally, slide the lift block down into the pipe and thread the draw cord through the grommet from the inside. Tie a washer to the end of the cord to act as a pull handle. Mount the holder to the wall leaving at least 48" above the top to allow removal of long dowels. Pulling the string lets you access even those short, bottom-dwelling dowels.

—Donald Whisman, Bremen, Ind.

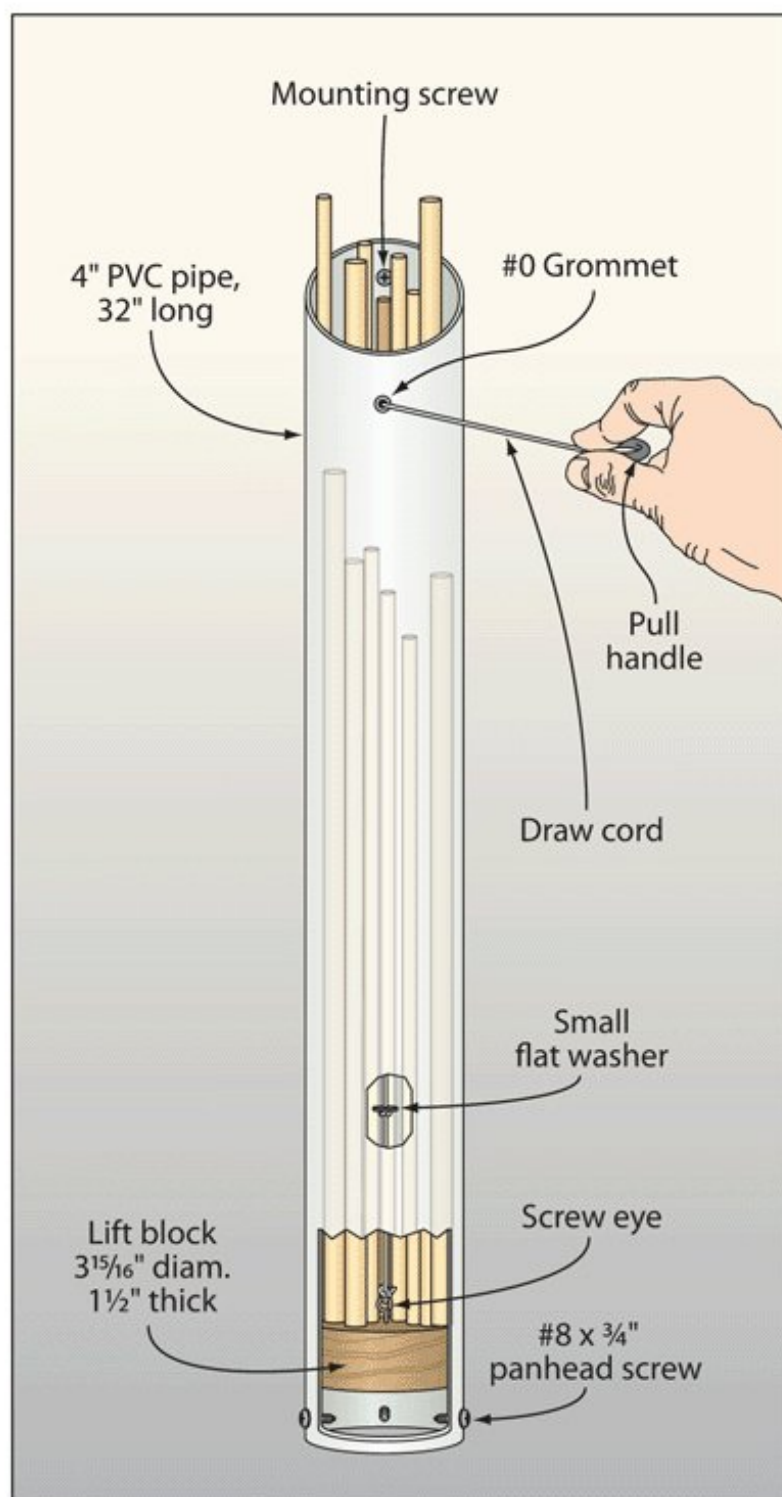

continued on page 12

He's a
tough guy.
But he
cleans
up after
himself.



No Residue Duct Tape.

To find out where to buy, go to
ScotchToughTape.com

Shop Tips

Completely capture the blank for DIY dowels

I saw the article about making your own dowels in issue 183 (May 2008) and wanted to share the simple jig I came up with to make $\frac{3}{4}$ " dowel for Boy Scout tool box kits. (It could be adapted for different sizes of dowel as well.) The jig captures the dowel blank for complete control, while the pusher block keeps fingers out of the block.

To use the jig, choose a round-over bit with a radius half the thickness of your blank, place the fence flush with the bit's bearing, and set the bit height to create a perfect quarter-round. With the dowel blank in place as shown, guide it through the router bit with the jig against the fence. Rotate the blank one quarter turn with each pass and in no time, you'll have a custom dowel.

—Kevin Godshall, Wyalusing, Pa.

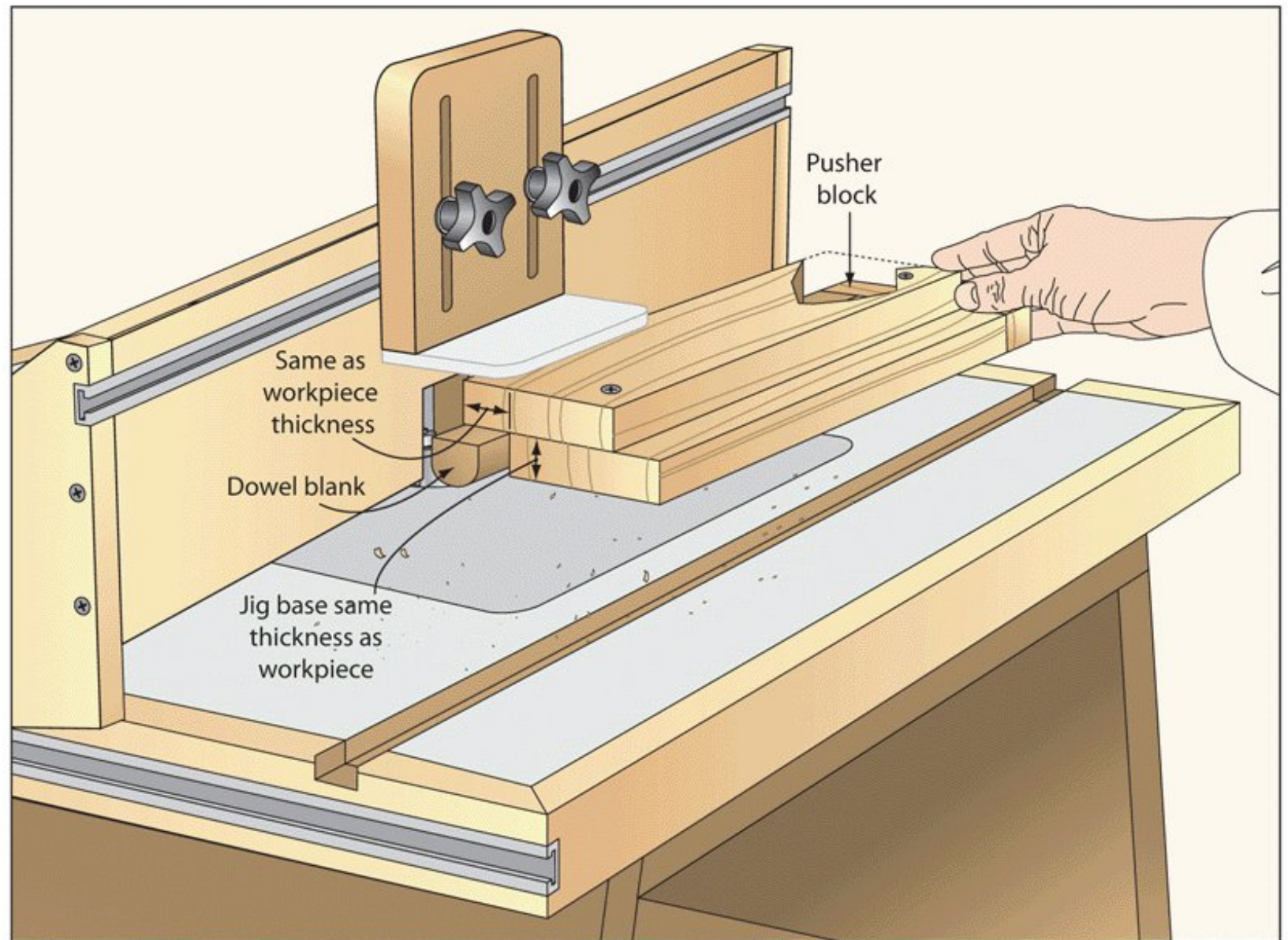

✓ Everyday Low Prices
✓ Easy To Use Website
✓ Huge Selection
✓ Fast Shipping

RA
ROCKAUTO.COM
ALL THE PARTS YOUR CAR WILL EVER NEED

GO TO WWW.ROCKAUTO.COM ROCKAUTO, LLC (EST. 1999)



Go bit fishing with magnetic bit bait

My large fingers have trouble pulling drill bits out of their metal case: I just can't seem to pull them straight out without binding. So I epoxied a small rare-earth magnet to the arm of my drill-press chuck key. Now I can just reach right in and snag any bit.

—Sid Jackson,
Candle Lake, Sask.

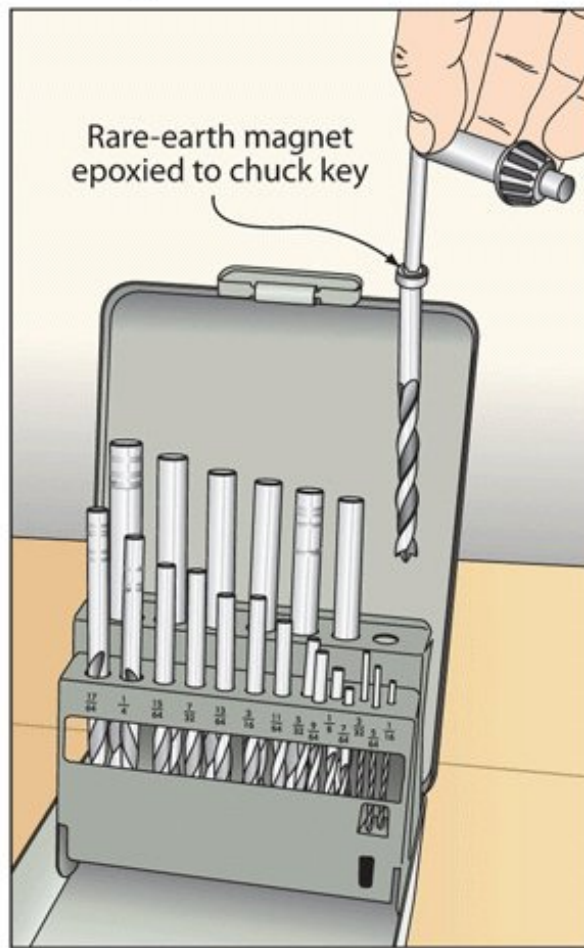

Get a grip for faster scrollsawing

I sell scrollsawn animals and puzzles at craft shows. Such projects require many tight turns that take a lot of time. To speed up your scrollsaw work, simply attach wooden door pulls to the waste corners of the cutting blank using a drywall screw and washer, as shown. Then back the screw out slightly so that the pulls turn freely.

Using the handles while cutting gives more leverage and makes cutting tight corners fluid and blade-mark-free. For me, the time-savings was significant enough that I could reduce the price of my puzzles.

Take care when passing the knob under the scrollsaw to avoid bruised knuckles from the saw arm. Also save the cuts near the handles for last, leaving them useful for the maximum number of cuts.

—James Mielke, Center City, Minn.

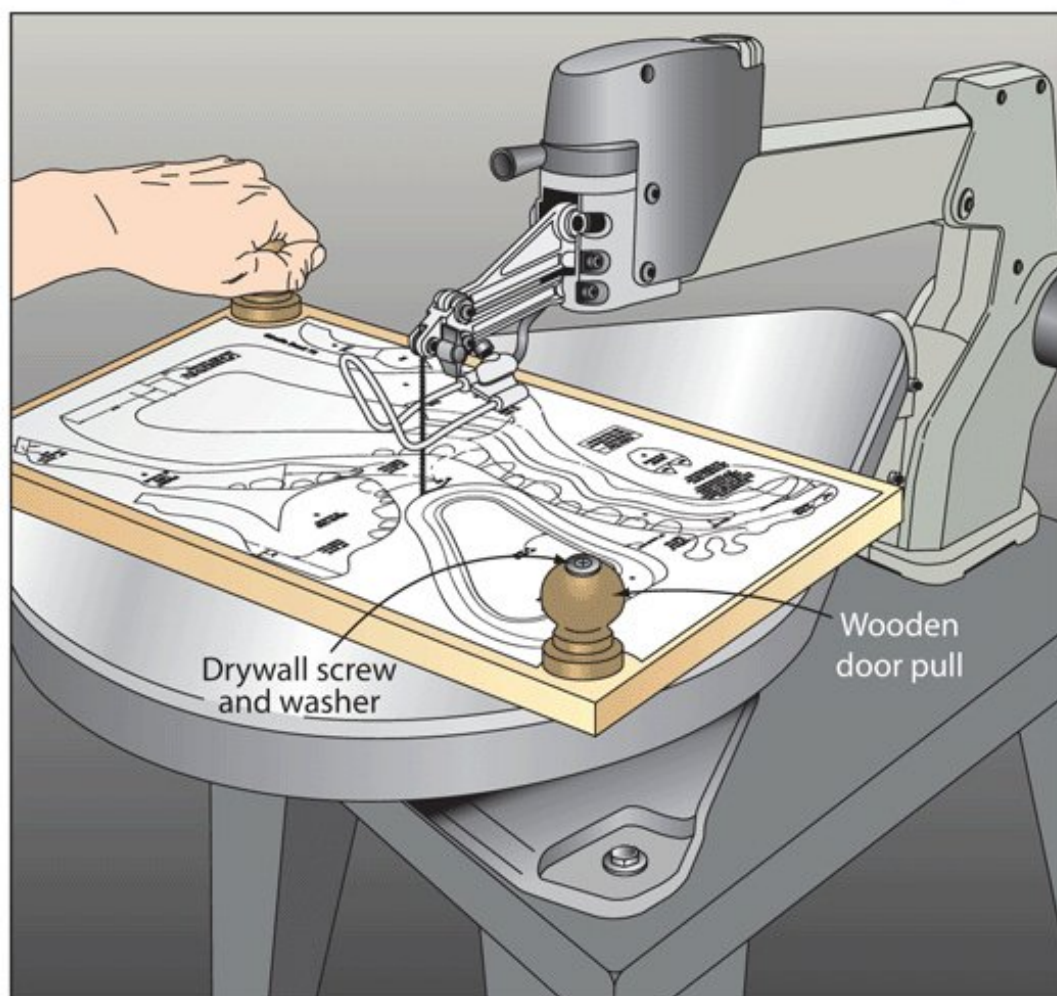

continued on page 14

He's a
tough guy.
But you
can see
right
through
him.



Transparent Duct Tape.

To find out where to buy, go to
ScotchToughTape.com

Ready for the Next Level?

Berea Brand Pen Kits!

Leading designer and manufacturer of quality writing instrument kits.

- High Quality
- Original Designs
- Reasonably Priced
- Retail and Wholesale

To Order call 1-877-736-5487 or go to our website www.bereahardwoods.com or email bereahard@aol.com

BereaHardWoods CO. Inc.
18745 Sheldon Rd • Middleburg Hts., OH 44130



WE'RE LEADING THE WAY

CMT ORANGE TOOLS™
ORANGE YOU GLAD WE'RE HERE?

X-TREME PERFORMANCE

CMT USA, Inc. • Toll Free: (888) 268-2487 • www.cmtusa.com

CMT ORANGE TOOLS
CABINETSHOP BLADE
221.060.10
10" 5/8" Bore 60T 1500

Shop Tips

An off-the-wall tablesaw safety reminder

We all know that it's good safety practice to unplug the tablesaw before changing the blade. But sometimes we get in a hurry or forget. To remind myself, I hang the tablesaw's arbor-nut wrench on a nail next to the outlet that powers the tablesaw. When I need the wrench, I know to unplug the saw as well. The saw cord's plug hangs on the nails so it's ready for me when it's time to plug it back in.

—Oliver Cook, Knoxville, Tenn.

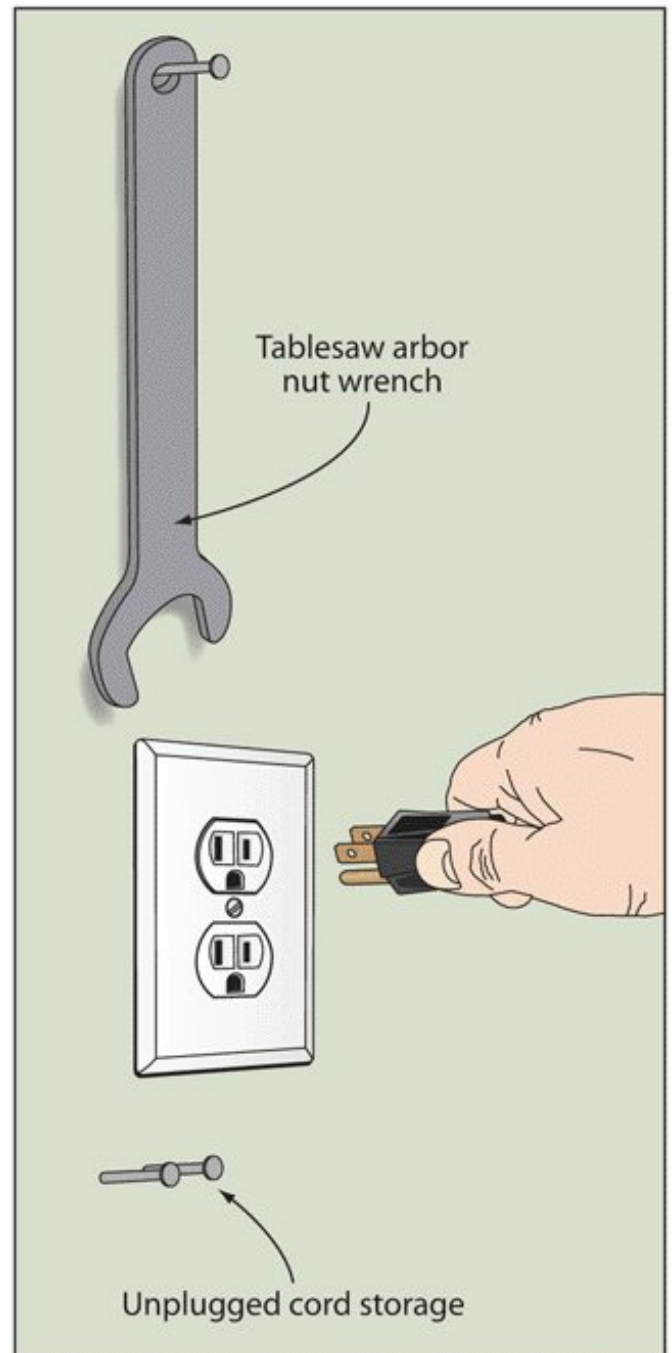

Build a Better Backyard



From planning a deck to putting on the final touches, you'll learn it all, step-by-step.

On Newsstands NOW

\$6.99 U.S.
\$8.99 Canada

Order online at woodmagazine.com/publications

or call toll free 888-636-4478

WD0710

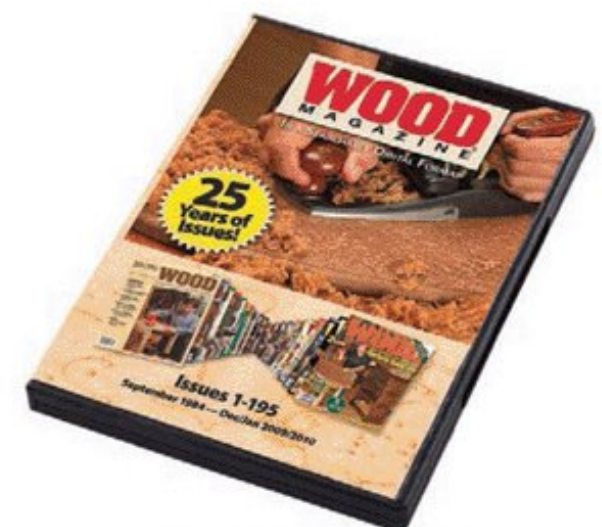

Get 25 years of WOOD magazine on DVD-ROM: woodmagazine.com/dvdlibrary

Tubs take a turn as handy saw horses

After a recent move, I had a collection of cheap plastic storage tubs left over. I was about to toss them when I realized they would make great substitute sawhorses. They're easier to use—and store—than foam sheets on the shop floor for cutting sheet goods, and like the foam, they won't harm the blade. They also work well as finishing stands. Glue, paint, and finish scrape off easily. I haven't dragged out my heavy steel and wood horses since I started using the tubs. 🌲

—Greg Pfeiffer, Colorado Springs, Colo.

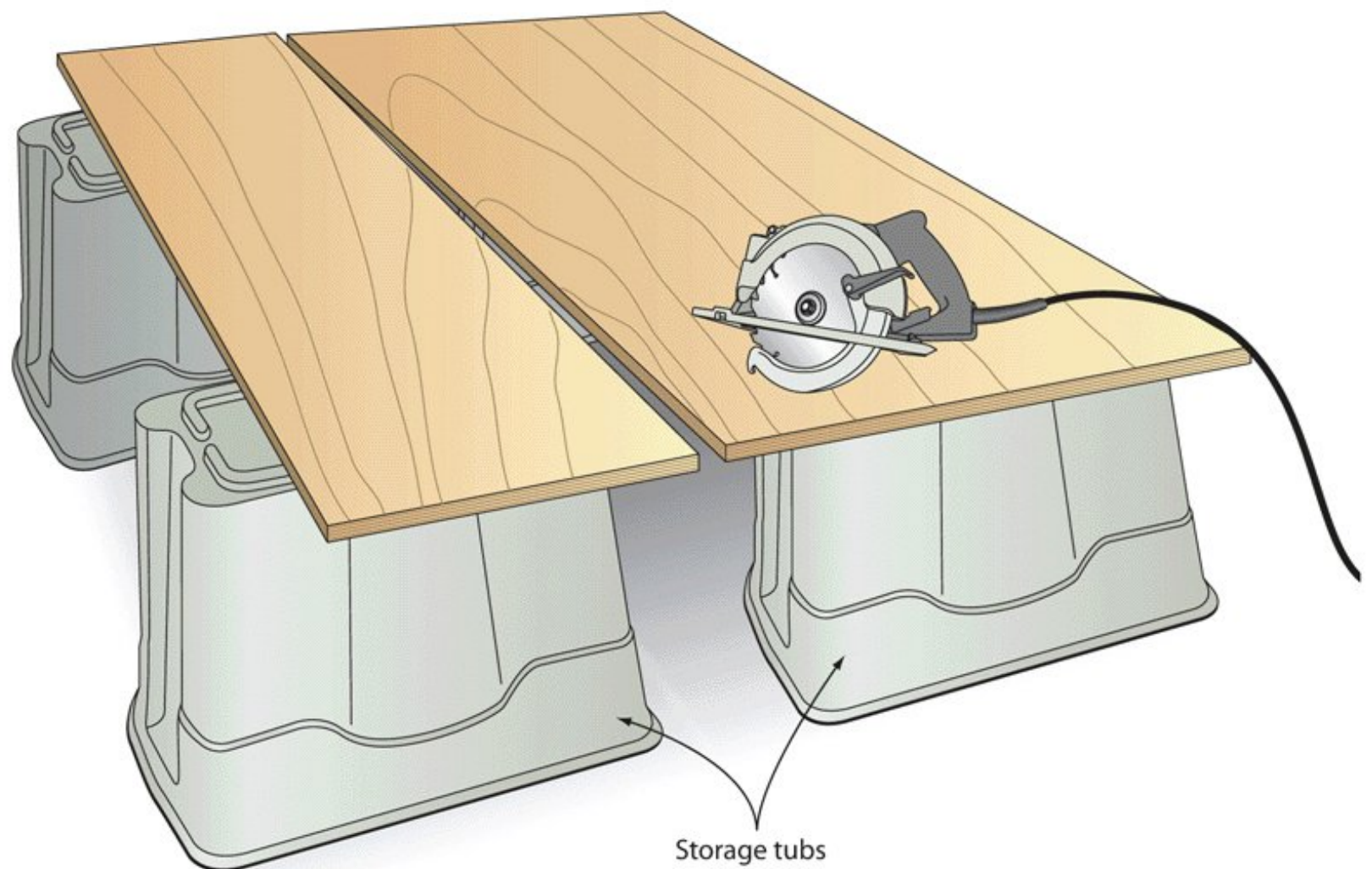

The new Turncrafter Commander Midi Lathes

More Power! More Features! More Fun!

Packed with features, the new Turncrafter Commander™ Midi Lathes are the most advanced, powerful and easy to use lathes in their class. These 10" and 12" swing workhorses will help you more easily, effectively and affordably tackle all your turning projects. Ask about our pen making starter sets and FREE pen making DVD!



\$399.95 (shown)

SAVE \$100

12" Swing 1HP Variable Speed
#TCLC12VS (UPS \$65)
(available June 2010)

\$299.95

SAVE \$100

10" Swing 3/4HP Variable Speed
#TCLC10VS (UPS \$55)

\$224.95

SAVE \$75

10" Swing 3/5HP Multi Speed
#TCLC10 (UPS \$55)

*Variable Speed versions only
**12" Variable Speed only

Penn State Industries
1-800-377-7297 www.pennstateind.com

Cures for Loose Dadoes

Sloppy slots can be a headache—here are three ways to mend them.

The quick fix: Shim it

Use veneer or rip a shim of matching stock to fill the remaining gap, sanding, if necessary, to create a tight fit. Place the shim on the side where it will least likely be seen. For example, few people will ever look under a low shelf, so put the shim below it. Install a shim on the top side of a high shelf. Glue the shim to the shelf and dado wall, trim or sand it smooth, and you'll likely be the only one to ever know it's there.



Cut or sand a shim to fit snugly; then score it flush with a utility knife. Remove the shim and trim it to size on your workbench.

Close a gap with a wedge

For gaps smaller than $\frac{1}{16}$ ", use a wedged spline to spread the ends of the inserted workpiece, tightening the fit. Begin by routing a $\frac{1}{8}$ "-wide, $\frac{1}{2}$ "- to $\frac{3}{4}$ "-deep slot centered along the board's end using a slotting cutter. (You can also cut a $\frac{1}{8}$ " kerf using your tablesaw, but long, unwieldy workpieces will need the support of a tall auxiliary fence.)

Next, cut a wedged spline with 5° bevels along each face, with the narrow edge the same thickness as your slot. Gently tap the spline into the slot. This might require some trial-and-error trimming or sanding to achieve the perfect fit.



Tapping the wedged spline into the slot spreads the workpiece end to tighten up any loose fit.

Fill the gap and start over

If the gap is too wide for either of the previous fixes, and you don't want to scrap the part, fill the dado with a strip of similar wood that closely matches in color and grain pattern, as shown *below*. Next, recut your dado to the correct width, making test cuts in scrap to confirm the fit. If possible, position the new dado so any sliver of the filler strip that will show is on the side that will be seen the least. 🌲



Cut a filler strip from scrap stock that closely matches in color and grain. Glue it in place; then plane or sand it flush.

Turn Shop Tips Into Cash!

WOOD® Magazine will pay you \$100 for each of your Shop Tips we print, and if your tip is judged best in the issue you'll get a tool prize worth at least \$300 (like this saw).



Send your tip or jig idea, along with photos or drawings and your daytime telephone number to: **Shop Tips, WOOD Magazine, 1716 Locust St., LS-221, Des Moines, IA 50309-3023.** Or e-mail the same to: shoptips@woodmagazine.com. Sorry, submissions can't be returned.

Breathe Easier with a One Stop Dust Collection Solution

With 20 years experience and a superior product line, the experts at Penn State Industries will provide you effective solutions for a cleaner shop.



INTRODUCING
The TEMPEST™ Portable
2 HP Cyclone Dust Collector
ONLY \$895
(plus shipping)
#TEMP2PCX

- 1025 CFM • Great filtration
- Ideal alternative to a double bag collector
- Roll up to your work anywhere
- Features maintenance free recirculating cleanout

TEMPEST™ S-series Cyclones

- ▲ 2.5HP - 1450CFM - \$995
- ▲ 3.5HP - 1700CFM - \$1125
- ▲ 5.0HP - 1800CFM - \$1395

Premium Ductwork

- ▲ Pipe for maximum airflow
- ▲ Fittings and hoods for most applications

Ductwork Planning Service

- ▲ An accurate layout of your shop to save you hours of planning

More Collection Solutions

- ▲ High performance bag-style collectors, air cleaners and portable collectors ideal for any size home shop

2 GREAT WAYS TO SAVE

FREE DUCTWORK PLAN

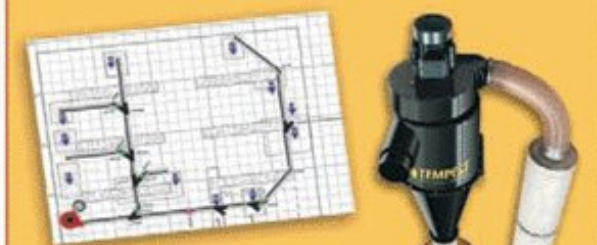

& \$100 OFF

any TEMPEST™ cyclone collector.
Call for details and mention code: WOOD8
Offer expires: 10/1/2010

Call Bill for your free consultation at 1-800-377-7297 x16 to help you plan the best solution for your shop or CNC application.

Penn State Industries

1-800-377-7297 • www.pennstateind.com/nodustwm

Make Your Own Cove Molding

Safely “shape” wide concave cuts using your tablesaw and these techniques.

Off-the-shelf cove molding from the home center is convenient, but it limits your choices in widths, profiles, and wood species. For custom molding that perfectly matches your project, create your own. Best of all, you don't need fancy machines—just your tablesaw.

The photo *above* shows the secret to doing this: Feeding stock at an angle across the blade cuts a concave profile. Using this procedure, we created a cove molding as an optional trim for the Entry-hall Bench on page 52 [Photo A]. With some experimentation, you can create a wide variety of cove profiles [Cove creativity, page 21] for your projects or maybe to trim a room.

Choose a blade and prepare your stock

To minimize scoring and reduce sanding, install a 60- or 80-tooth crosscut blade in your tablesaw. You'll also need two scrapwood fences to place diagonally across the saw table, capturing the blank while you cut it, as shown *above*. Joint one edge of each fence square to a face.

For the 3 $\frac{3}{8}$ "-wide molding used on the hall bench, prepare blanks 4 $\frac{1}{2}$ " wide with parallel edges. The extra width allows for bevel-rips made after cutting the cove [Drawing 1].

Quick Tip! Better long than short. Make more molding than you need. It's easier to make extra now than to try to duplicate a setup later.

continued on page 20



A CREATE A CUSTOM MOLDING

Customize the Entry-hall Bench on page 52 by replacing the store-bought crown molding with shop-made cove molding.

1 COVE PROFILE

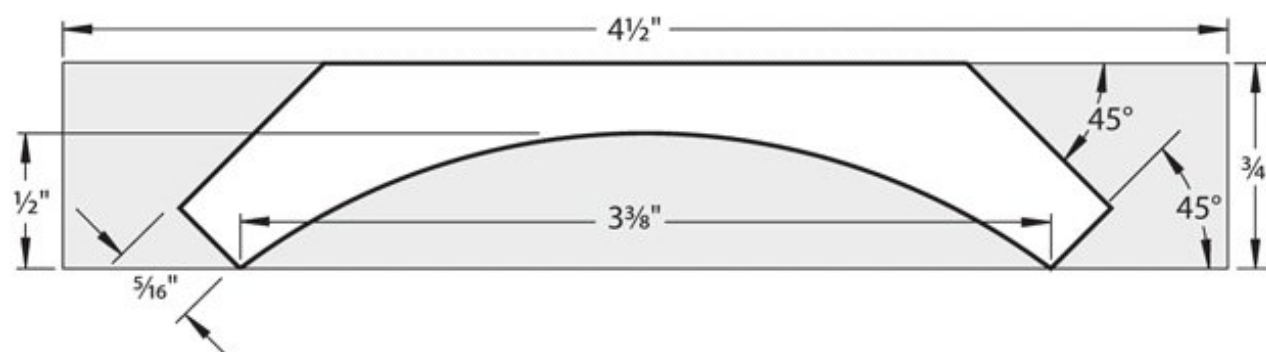

TAKE YOUR BEST SHOT



FN1664K
16 Gauge Finish Nailer

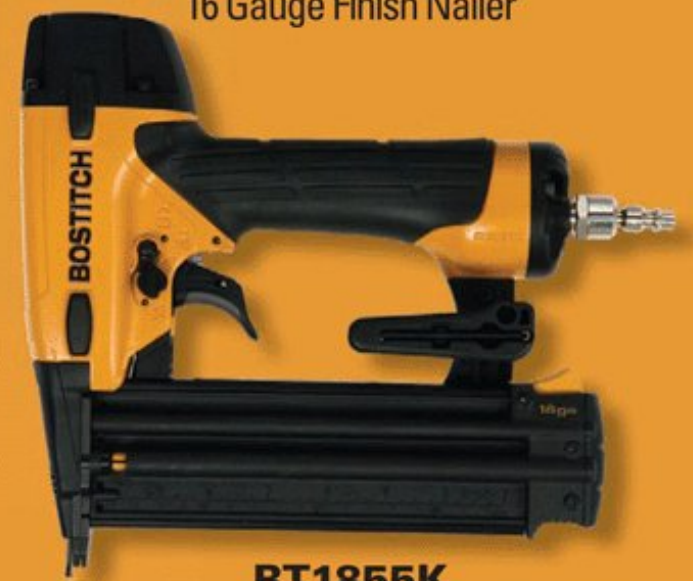

BT1855K
18 Gauge Brad Nailer



SX1838K
18 Gauge Finish Stapler

Our new oil-free finish nailers are engineered to help you achieve the level of craftsmanship you were always capable of. They offer precision-driven features such as dry-fire lockout, dial-a-depth technology, swivel fittings, patented profile tips . . . even an integrated pencil sharpener.

For nearly 40 years, Stanley-Bostitch has designed its products to be the most reliable & durable pneumatic tools available. Maybe that's why more finish carpenters and serious woodworkers rely on Stanley-Bostitch products more than any other major brand*



*Based on third-party survey in U.S. and Canada asking for the brands of finish products used in the previous 12 months.

© 2009 The Stanley Works

www.bostitch.com

STANLEY

BOSTITCH®

Challenge Skill

TAPE MARKS THE SPOT

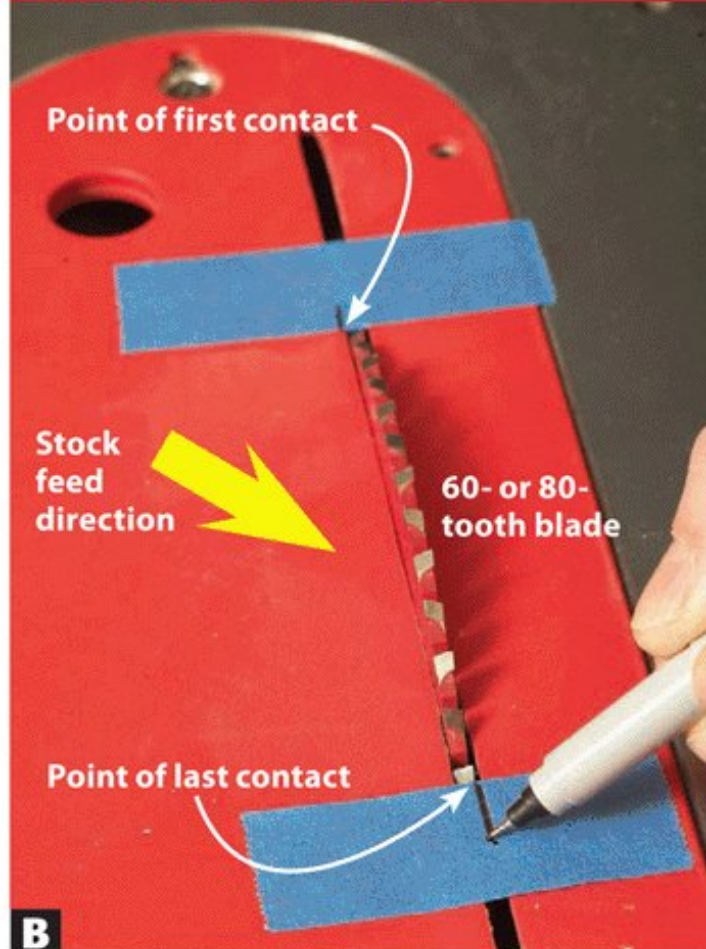

B Mark on the tape where the stock will first contact the front tooth of the blade and where it will last contact the rear tooth.

POSITION THE JIG

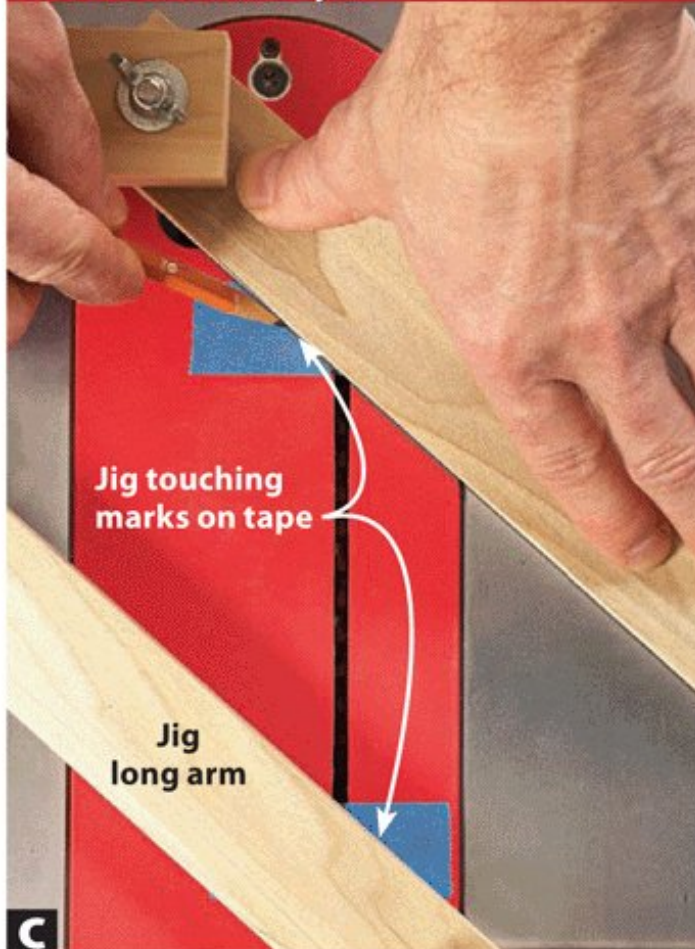

C Align the jig so the inside edges of the long arms touch the marks on the tape. Mark one long inside edge of the jig onto the saw table.

MEASURE THE OFFSET

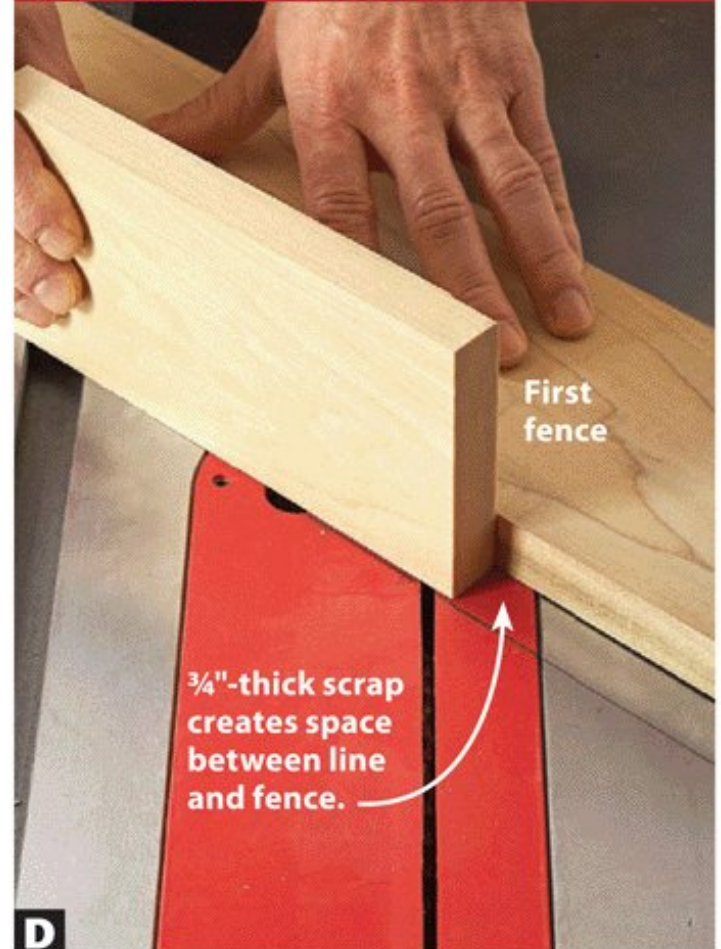

D A scrap between the line and the fence creates space between the cove and the edge of the blank. Clamp the first fence in place.

Start by setting the fences

A simple fence-setting jig [Drawing 2] determines the proper angle for the fences on the tablesaw. Build the jig as shown, ensuring that opposing sides are parallel.

Set the distance between the jig's long arms to the width of the cove and tighten the wing nuts to lock the jig in shape. Raise the tablesaw blade to the final depth of the cove ($\frac{1}{2}$ " for our example), and use painter's tape to mark where the teeth enter and exit the throat plate [Photo B]. Lower the blade and use the marks to position the jig [Photo C]. After marking one inside edge of the jig onto the tablesaw top using a pencil as shown, remove the painter's tape and clamp the fences in place [Photos D, E].

SET THE SECOND FENCE



E Place a molding blank against the first fence to position the second fence. The blank must slide between the fences without binding.

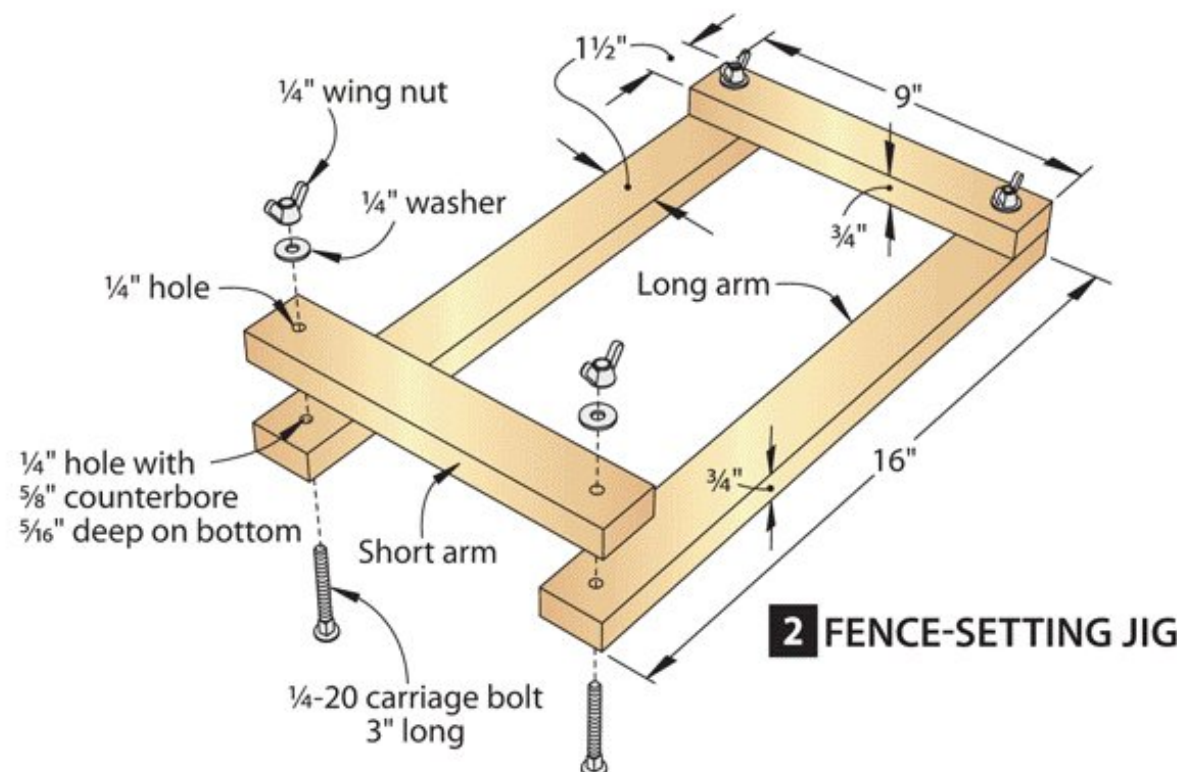

2 FENCE-SETTING JIG



Watch a FREE video showing how to make cove molding at woodmagazine.com/tscope

Cut the cove

Form the cove by making a series of passes over the blade. To start, set the blade height $\frac{1}{16}$ " above the table. Turn the saw on and use push blocks to slowly feed the molding blank over the blade [opening photo, page 18]. Raise the blade $\frac{1}{16}$ " and make another pass. Repeat this procedure until you reach the final cove depth.

Quick Tip! Lighten up and be smooth. A slow final pass removing $\frac{1}{32}$ " or less leaves a surface that requires less sanding.

Using the newly cut molding as a template, trace the profile of the cove onto the end of a piece of foam insulation and cut it to rough shape at the bandsaw or with a coping saw. Sand the block to final shape [Photo F]; then sand the cove starting at 100 grit and working up to 220 grit.

Lay out the molding profile on one end of each cove blank [Drawing 1] and bevel-rip the edges to complete the molding [Drawing 3].

Safety Note: Use a zero-clearance insert to prevent the waste from catching between the throat plate and the blade.

MOLD A CUSTOM SANDING BLOCK

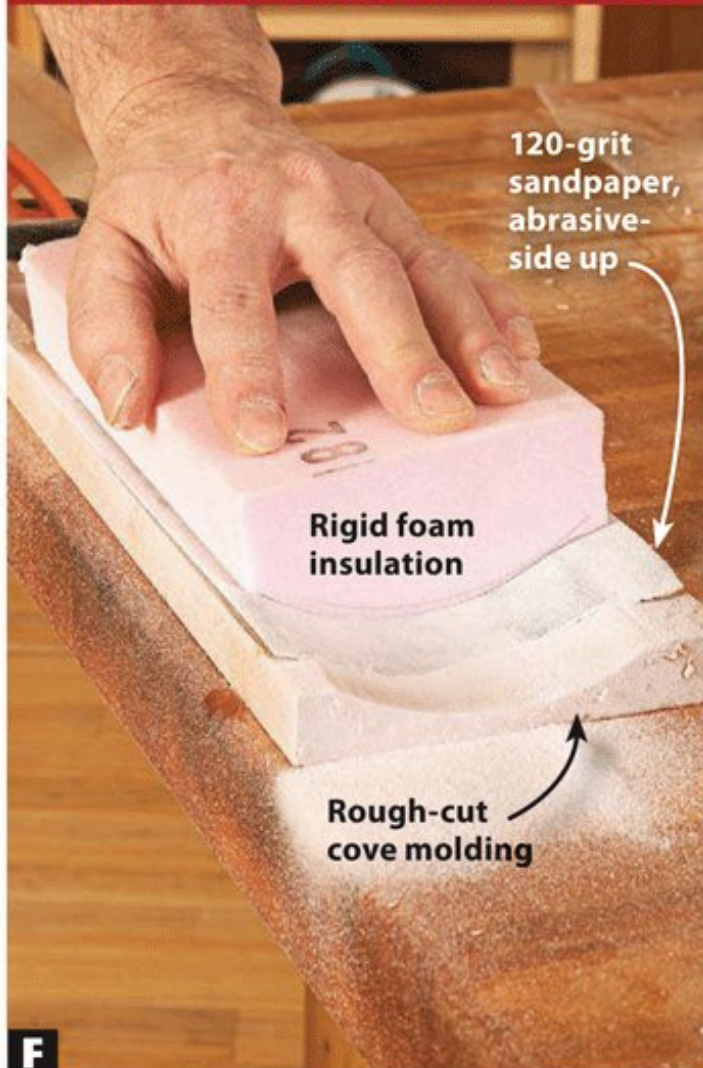

F Place sandpaper in the cove and rub a block of foam insulation across it to make a sanding block that perfectly matches the profile.

3 COVE MOLDING BEVEL RIPS

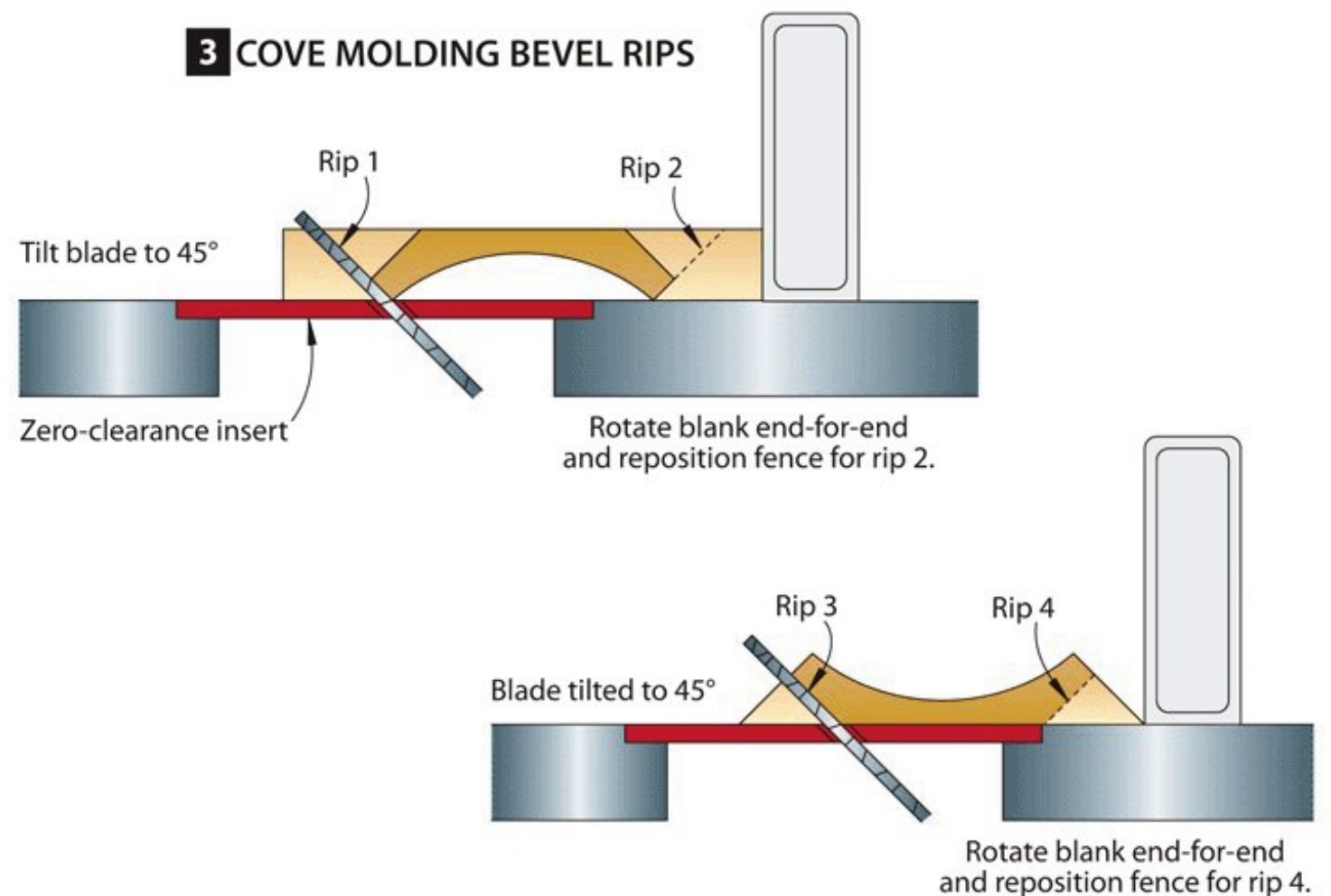

Cove creativity

Three variables determine the profile of cove molding shaped on the tablesaw: the feed angle of the stock over the blade; the blade height; and the blade tilt angle. Different combinations of these three elements create a variety of profiles. (See the actual size drawings below.)

Feed angle

A shallow feed angle cuts a compact, elliptical cove [top drawing]. Higher feed angles broaden the curve to a near semi-circular profile.

Blade height

Final blade height determines the depth of the cove. To see the cove depth cut by a $\frac{3}{8}$ "-high blade, for example, cover

the **top drawing** just below the $\frac{3}{8}$ " line (shaded area). The depth of the profile shows above the line (unshaded area).

Blade tilt

A blade set 90° to the table cuts a symmetrical cove [top drawing]. Tilting the blade creates asymmetrical coves that "lean" to one side [bottom drawing].

Safety Note: When tilting the blade, feed the stock from the direction the blade tilts. So if your blade tilts to the left, feed the stock from left to right. If it tilts to the right, feed right-to-left.

Experiment to find profiles you like. Save short lengths of your samples and write the feed and blade tilt angles on them for future reference.

PROFILE CUT WITH BLADE 90° TO TABLE

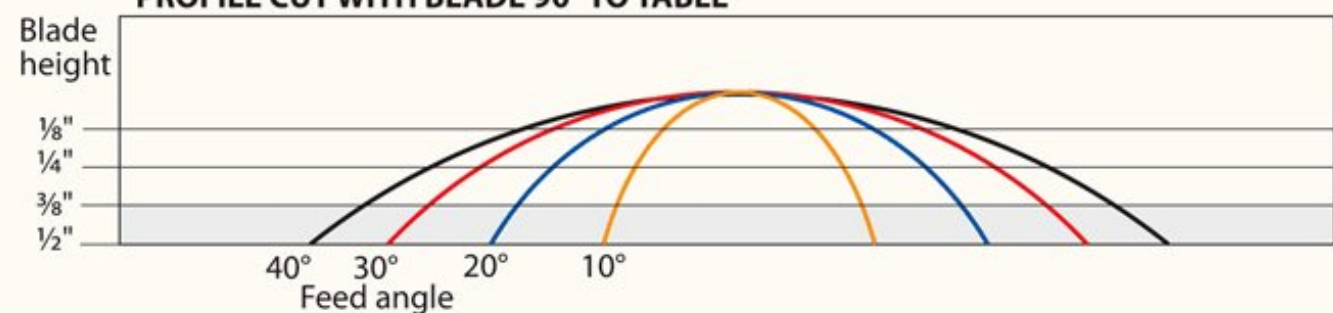

PROFILE CUT WITH BLADE TILTED 35°

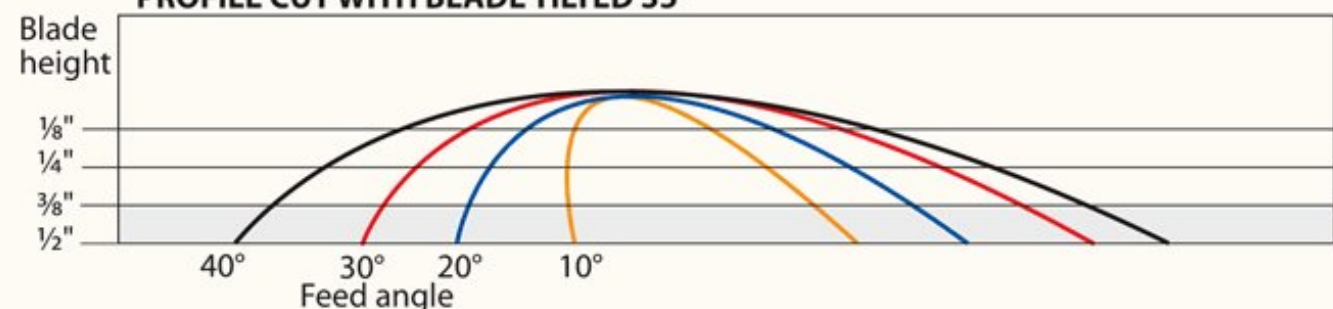

Spiral vs. Straight Bits

Even with more router bit choices than ever, there's still a place for straight bits.

Spiral bits plow through material the way business jets slice through the sky; but neither of these high-tech tools fit everyone's budget. Like a coach-class airline ticket, a standard straight bit gets you where you need to be, and for a lot less money.

So why pay for the upgrade? All spiral bits share one advantage over straight bits: Their angled cutting edges slice, instead of chop at, the wood. This leaves a cleaner cut because a portion of the cutting edge constantly touches the wood. And unlike straight bits with carbide cutters brazed to a steel body, spiral bits are all carbide. That lets bit-makers use wear-resistant carbide formulas that stand up better to abrasive glues and resins in plywood, particleboard, and medium-density fiberboard. Most spiral bits use one of three flue patterns:

Up-cut. (Picture the left-to-right rise of the spiral.) Like a twist drill bit, these bits quickly evacuate chips from deep cuts. They lift the veneers on sheet goods when making plunge cuts, but push down on veneer when used in a table-mounted router with the "good" side up on the workpiece.

Down-cut. These spiral bits press veneer down as you make plunging cuts for dados, rabbets, and grooves. They don't clear chips as well as the

others, so use multiple ¼"-deep passes, or cut relief kerfs with your tablesaw. Be careful: The downward force can lift a handheld router off your workpiece.

Combination. Up- and down-cut flutes meet in the middle of the bit (*below*) to compress veneer on both faces of a panel tightly against the substrate.

These big three have been joined by such specialty spirals as bearing-guided up-cut and down-cut flush-trim bits for template work and combination bits with short up-cuts and longer down-cuts for chip-free mortises.

When to turn to spirals

Spiral bits, with their shearing action, make sense for hard-to-machine woods with complicated grain patterns, such

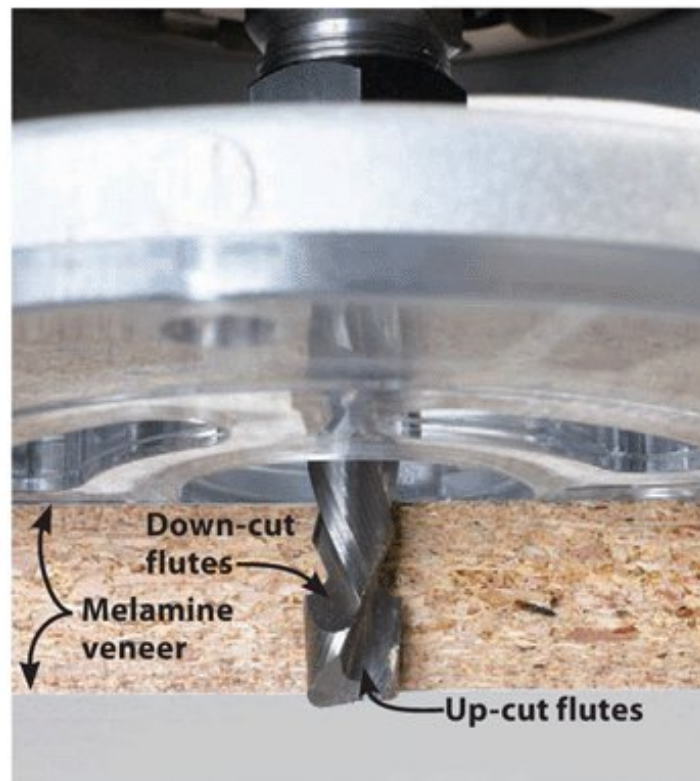

On a combination bit, the down-cut and up-cut flutes both press veneers against the particleboard substrate.

as curly maple, and for veneered sheet goods. That speed and cut quality doesn't come cheap, but you can justify their prices a lot more easily when you reduce tear-out waste in an \$80 sheet of quartersawn oak-veneer plywood.

For example, one Internet source sells a ½×1¼" straight bit for \$18, but an up-cut spiral bit the same size costs \$47. A ½×1½" bottom-bearing straight flush-trim bit costs \$21 versus \$111 for a comparable down-cut flush-trim bit.

In addition to their lower price, straight bits work best on wide cuts. While the all-carbide construction of spiral bits limits their width to ½", straight bits can cut a path up to 1½" wide for single-pass cleanup of tablesaw dados and rabbets.

So hold onto your wallet, and push your straight bits to their limits. Then use our chart on the *next page* to choose the best bits for your job.

Sources

The following companies offer a variety of spiral router bits:

- Amana Tool**, 800-445-0077; amanatool.com.
- CMT**, 888-268-2487; cmtusa.com.
- Eagle America**, 800-872-2511; eagleamerica.com.
- Freud**, 800-334-4107; freudtools.com.
- Lee Valley**, 800-871-8158; leevalley.com.
- MLCS**, 800-533-9298; mlcswoodworking.com.
- Rockler**, 800-279-4441; rockler.com.
- Whiteside**, 800-225-3982; whitesiderouterbits.com.
- Woodline USA**, 800-472-6950; woodline.com.
- Woodcraft**, 800-225-1153; woodcraft.com.

Match the router bit to the material you're working

To use this chart, start with the type of material you're routing. Then decide whether you'll be doing more plunge routing or edge work. From there, trace the colored line to the best straight or spiral bit(s) for your application.

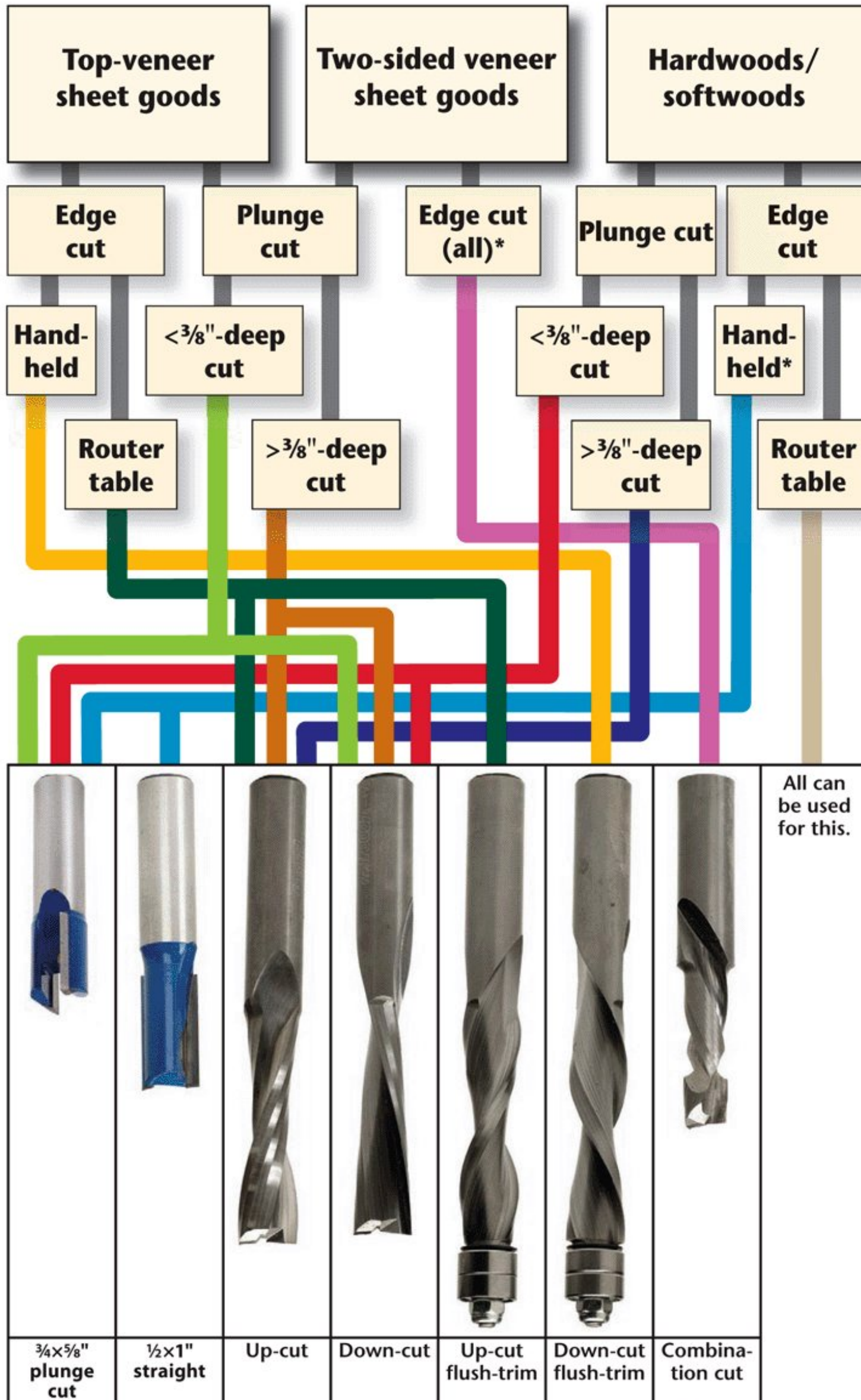

*Handheld routing with non-bearing bits requires a router edge guide. 🌲

Put the world's best woodworkers in your pocket

Shop for dozens of downloadable videos from top woodworkers. View them any time on your computer, or take them with you on your iPod or other portable media player.

woodmagazine.com/videos

Better Woodworking

Great Ideas for Your Shop

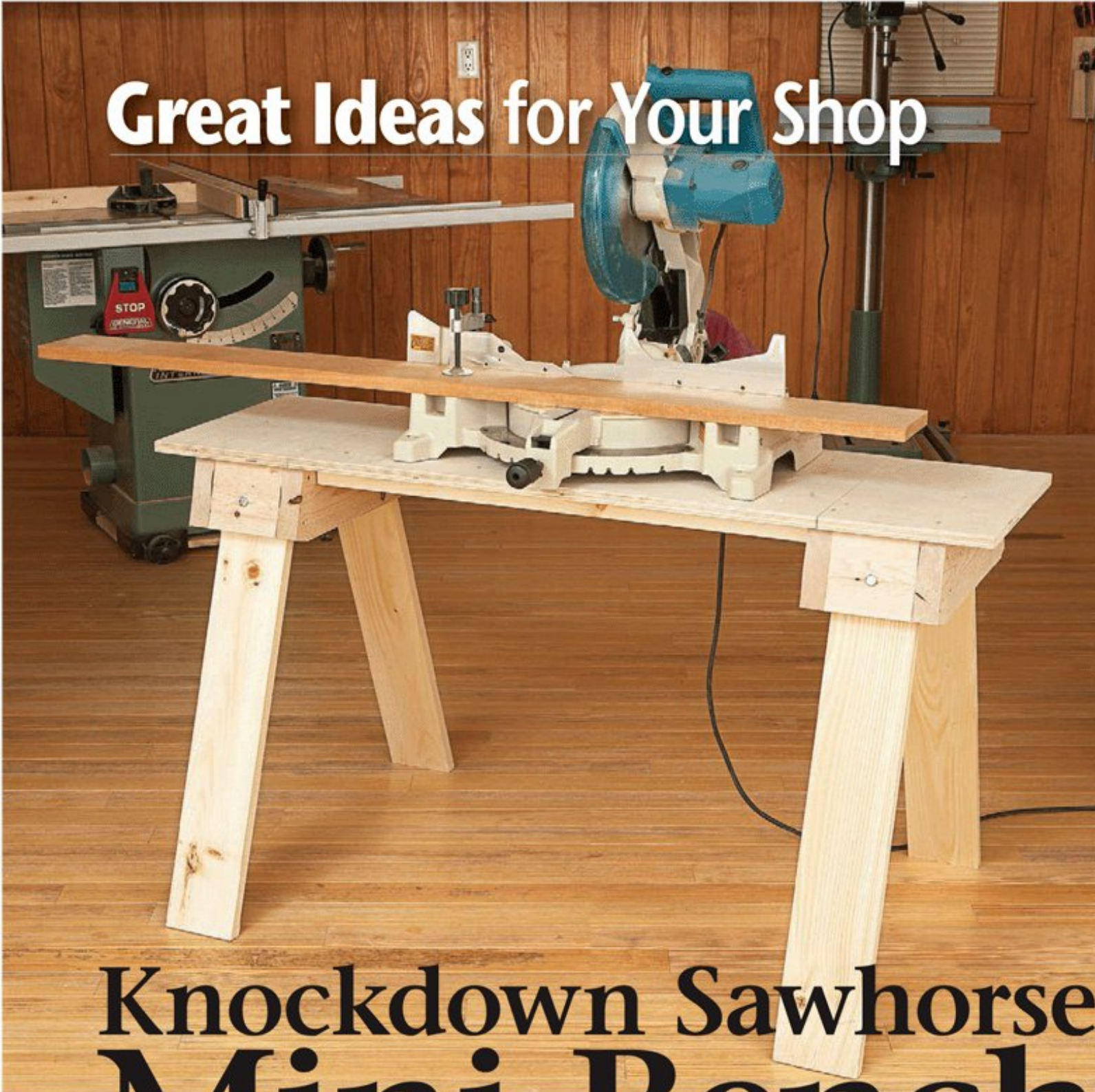

Knockdown Sawhorse Mini Bench

Short on space but long on the need for affordable and versatile workshop surfaces? This quick-and-easy project design serves two purposes: Build a pair for use as sawhorses, or add the cleated center

panel to create a mini workbench. The splayed legs and wide top make for a sturdy but compact work center. To keep the construction simple, use $\frac{3}{4}$ "-thick solid stock or plywood for all but the center beam, outside and inside

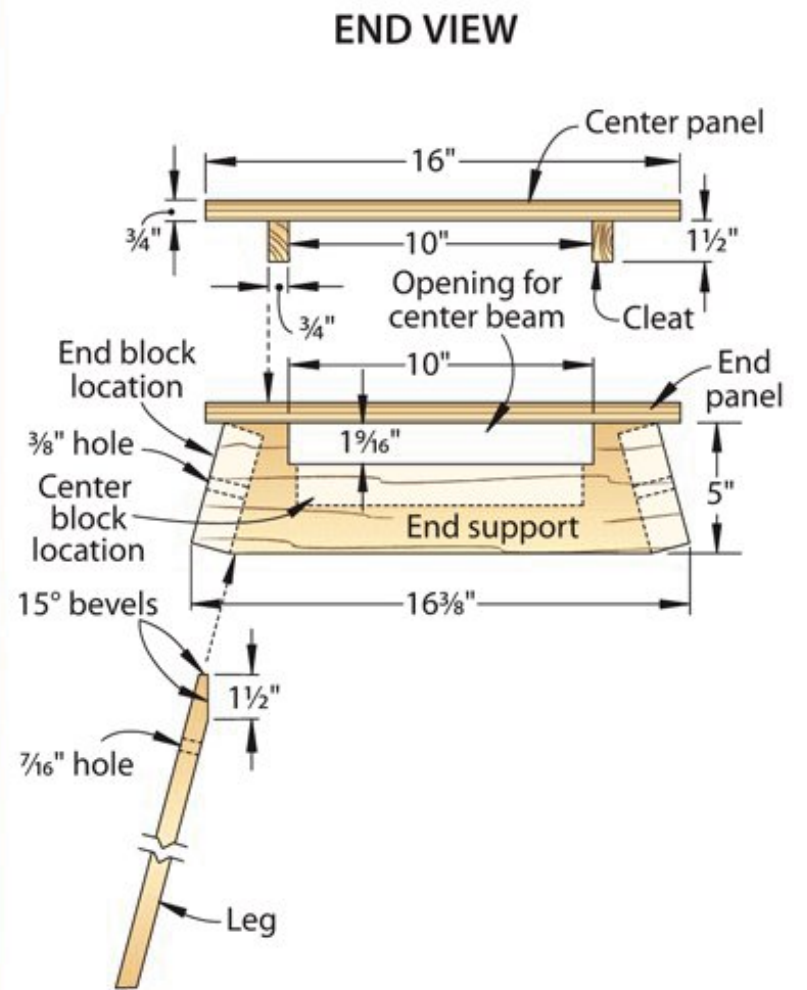

blocks, and center blocks. For those, choose 2x stock.

Cut all parts to size and assemble the end supports in the configuration shown in the **End View drawing**. Slide the legs into the end supports and drill a $\frac{3}{8}$ " hole through each of the four end blocks and legs. Remove the legs and enlarge the leg holes to $\frac{7}{16}$ ". (Slightly larger holes in the legs make it easier to align the leg block and leg holes and slide the $\frac{3}{8} \times 2\frac{1}{2}$ " bolts in place when installing the legs.)

To assemble the pieces, follow the four-step process on *page 26*. The $\frac{3}{8}$ " bolts are used strictly as pins, so nuts are not required.

To stow the horses, simply pull the $\frac{3}{8}$ " bolts that pin the legs to the end blocks, and stack the pieces, as shown in **Photo 1** on *page 26*.

Project design: **Keith Schwartztrauber**, Las Vegas

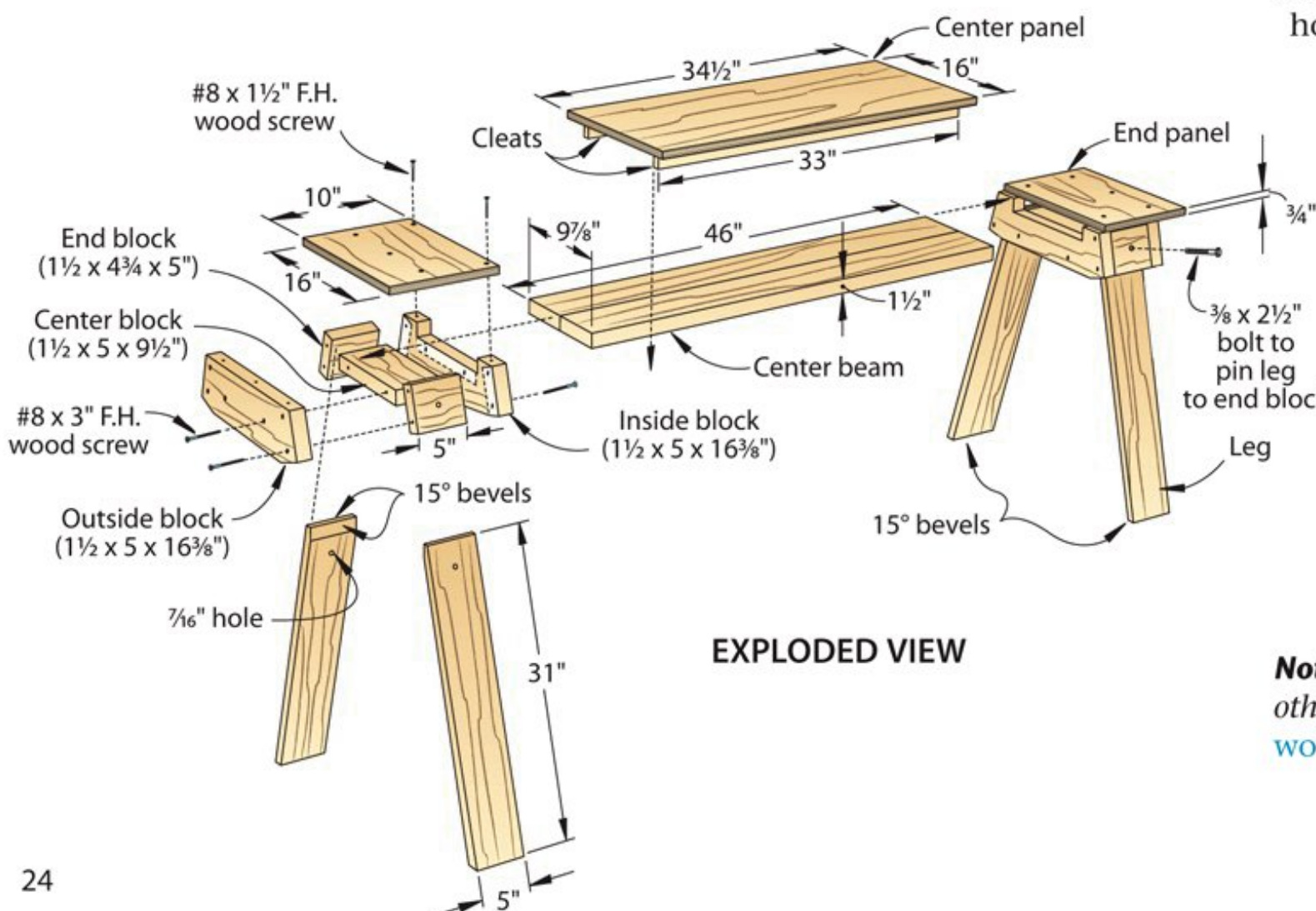

EXPLODED VIEW



Note: Check out Keith's shop, as well as 12 other top shops, by visiting woodmagazine.com/ABHW2009

continued on page 26

Premier

FUSION

The New Standard In General Purpose Saw Blades

 <p>freud (The New Standard) High Angle ATB Grind</p>	<p>Others (Standard) Low Angle ATB Grind</p> 	<p>Freud's Fusion Tooth Design</p>
 <p>freud (The New Standard) Double Side Grind</p>	<p>Others (Standard) Single Side Grind</p> 	



freud
Precisely the best.
www.freudtools.com
(US) 1-800-472-7307
(Canada) 1-800-263-7016

Featuring:

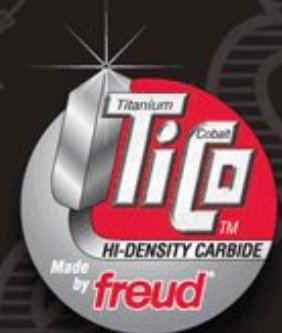

TiCo™ hi-density carbide stays sharper longer for extended blade life



Perma-SHIELD® permanent non-stick coating for less blade drag and superior performance



Unique anti-vibration design with special polymer filler dampens vibration for smoother cuts

Woodworkers have been searching for a superior general purpose blade – the one blade that truly does it all. The search is over.

Freud is proud to offer the discriminating woodworker the Premier Fusion Saw Blade - The New Standard in General Purpose Saw Blades. The patent-pending Premier Fusion blade is the most technologically advanced blade on the market with a radical new "Fusion" tooth design that combines a double side grind with a 30 degree Hi-ATB to produce a glass-smooth, chip-free top and bottom surface while ripping and crosscutting. The unique Fusion tooth design, combined with Freud-made TiCo™ Hi-Density General Purpose Blend of Carbide, superior anti-vibration design and patented Perma-SHIELD® non-stick coating make for the ultimate general purpose saw blade.

Choose from four blades in the Premier Fusion series – 8", 10", 12" and 14". Use a Premier Fusion blade once and you'll be convinced that it is the best general purpose saw blade that you have ever used – guaranteed.

Perfect for:

- Thick Stock Lumber
- Melamine & Laminates
- Veneered Plywoods
- Softwoods
- Hardwoods
- Crosscutting
- Ripping

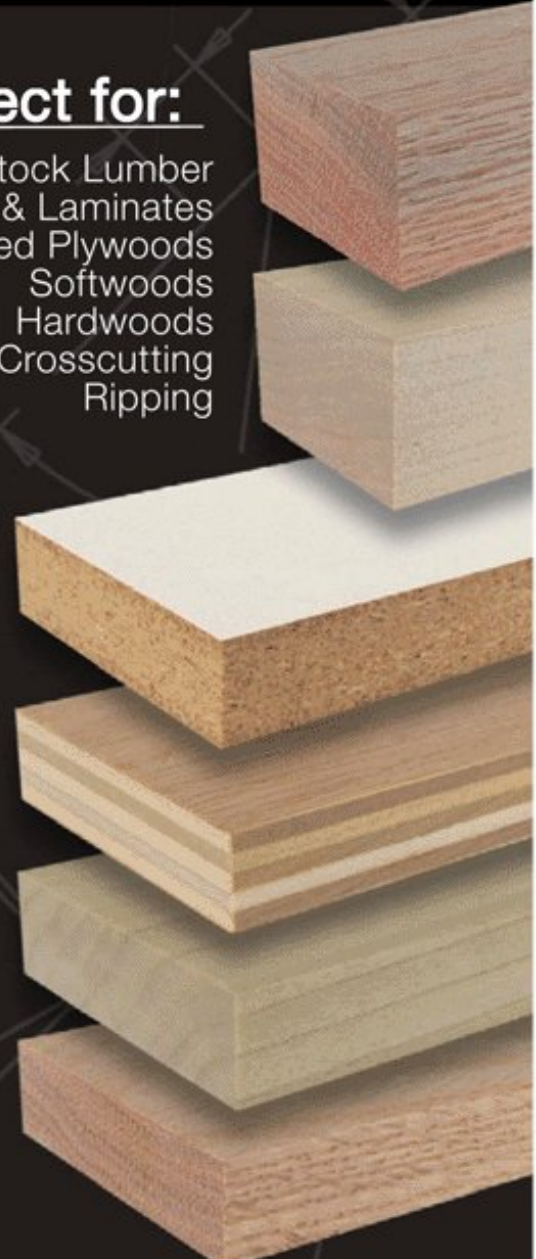

Assemble the sawhorse/mini bench in no time.

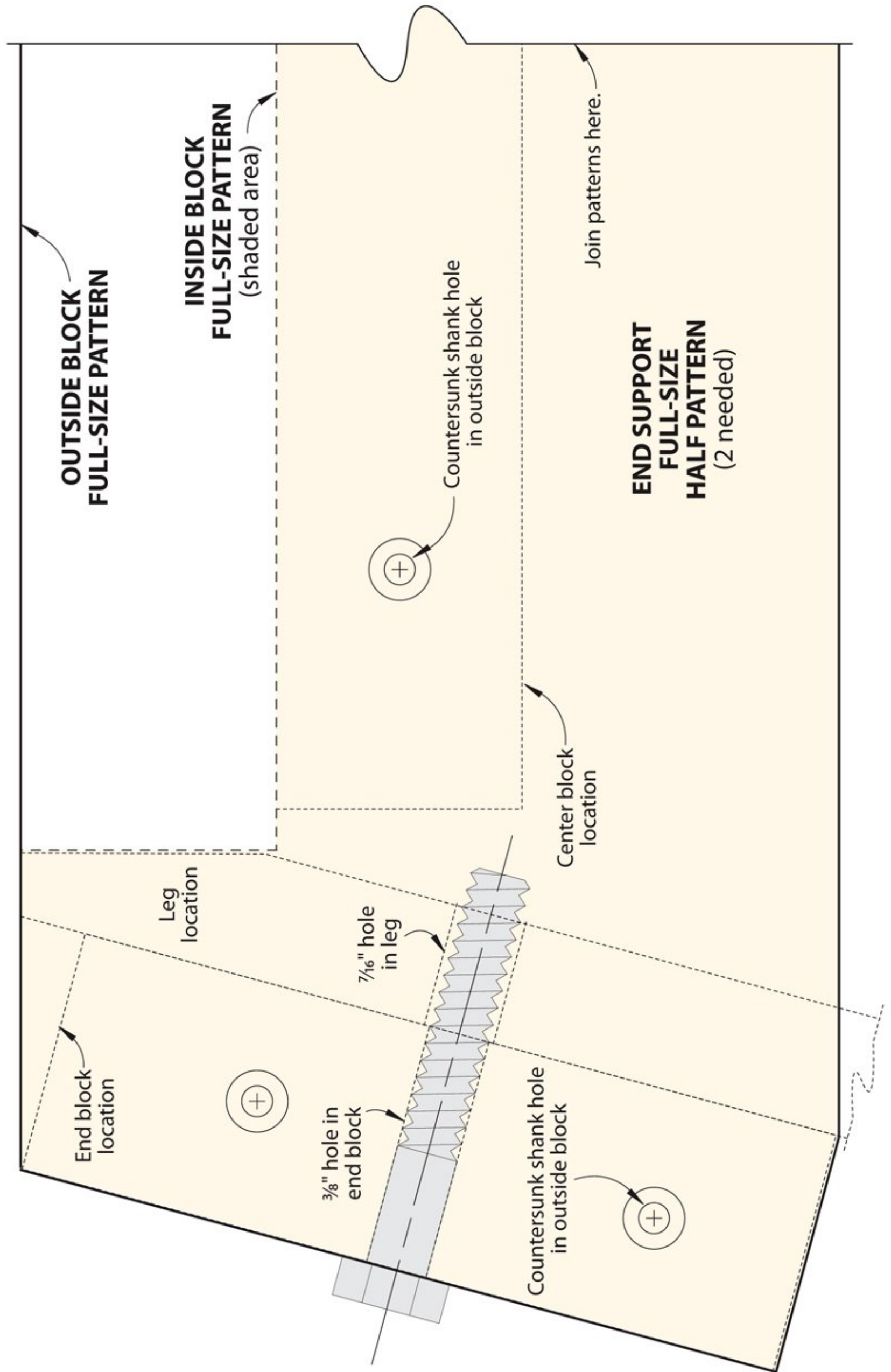
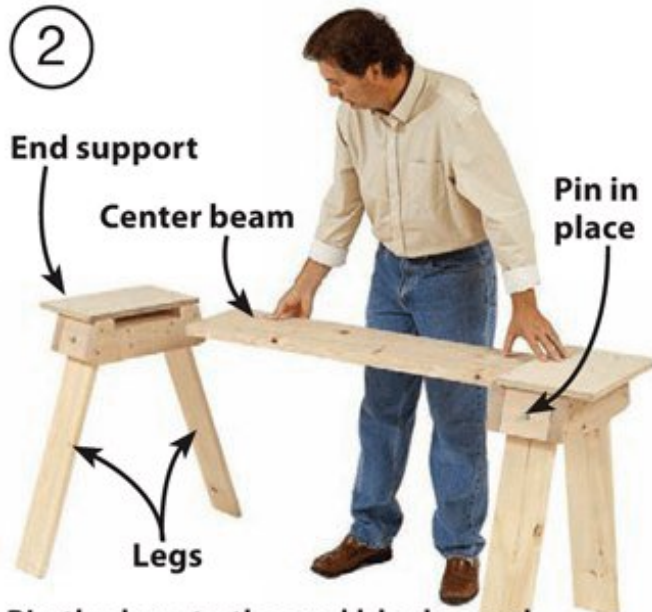
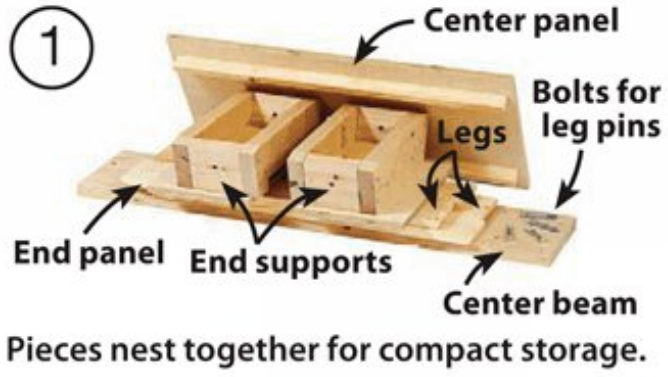

Refinish Your Future.



Own your own business.

Let your passion for furniture lead you into a new business with a Furniture Medic franchise. We're a complete on-site repair and restoration-refinishing business servicing homes and companies as well as handling moving and insurance claims. We offer extensive training and support with a low initial investment and manageable overhead. Financing is available to qualified candidates and franchises are offered nationwide. Call today to brush up on the details.



www.furnituremedicfranchise.com

1-800-RUN YOURS

GUIDE KITS | STABILIZERS | BLADES | TIRES | AND MORE

"CARTER GUIDES MADE MY BANDSAW FUN AGAIN!"

INCREASE CUTTING SPEED & ACCURACY.

FREE!
"Bandsaw Tuning" DVD with purchase of Guide Kit or Stabilizer.™

Limited Time Offer:
Use Promo Code BHGD1.
Code must be included with order.

Carter products
BANDSAW UPGRADES

See Carter Products at The Woodworking Shows in 23 cities. thewoodworkingshows.com

carterproducts.com/bandsawfun | 888.622.7837

Forrest Blades

Experienced woodworkers know that Forrest blades are ideal for remodeling high-end kitchens and baths.

Forrest blades deliver smooth, quiet cuts *without* splintering, scratching, or tearouts. Our proprietary manufacturing process, hand straightening, and unique grade of C-4 micrograin carbide are perfect for cabinets, countertops, and flooring. In fact, independent tests rate us #1 for rip cuts and crosscuts.

"Your blades are without question the best by miles, and I have tried them all."
Bob Jensen, Fridley, MN

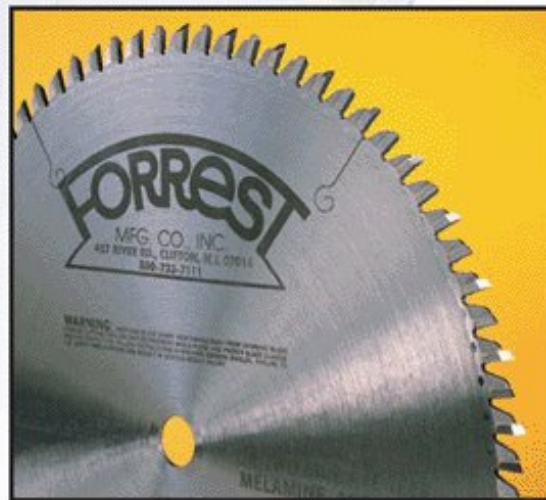

Our blades are manufactured in the U.S.A. and backed by our 30-day, money-back guarantee.

Forrest Quality Shows

Duraline Hi-AT—Great for cutting two-sided veneers and low pressure laminates.

Woodworker II—Best rated, all-purpose blade for rips and crosscuts.

Order from any Forrest dealer or retailer, online, or by calling directly.

FORREST

The First Choice of Serious Woodworkers Since 1946

www.ForrestBlades.com
1-800-733-7111
(In NJ, call 973-473-5236)

© 2010 Forrest Manufacturing Code WM

Woodworker II
Fine Woodworking



Chop Master
Woodshop News



Duraline Hi-AT
Woodshop News



Dado King
Wood Magazine



4-WAY MONEY MAKER

MOLDS • PLANES • SANDS • SAWS



- Shape 3 sides per pass!
- 500+ Molding Patterns!
- RISK FREE 30-Day Trial!
- Highest Profit: MAKE CURVED MOLDING!

Own a 4-in-1 MOLDING FACTORY!



Quick-Change Molding Head



Commercial-Duty Planer



Power-Feed Drum Sander



Gang Ripsaw Attachment

Now, turn a \$5.00 rough board into \$75.00 worth of high-dollar molding in minutes. Make over 500 patterns, plus curved molding, tongue & groove, picture frame stock, custom designs. QUICKLY CONVERTS from Molder/Planer to Drum Sander or Multi-Blade Ripsaw. Made in U.S.A. 5-Year Warranty. 12", 18" or 25" models available.

NEW! SHAPE 3 SIDES IN 1 PASS!

Turns your Woodmaster into a POWERFUL 3-SIDE MOLDER that efficiently & AFFORDABLY cuts T&G flooring, paneling, & more!

NEW!

FREE DVD & BUSINESS STARTER KIT!
Call TOLL FREE 1-800-821-6651 Ext. P350

Woodmaster Tools, Inc. Dept. P350,
1431 N. Topping Ave., Kansas City, MO 64120 www.woodmastertools.com

Shop Skills

How to Sharpen a Card Scraper



Card scrapers clean up a workpiece like no other tool, leaving a scratch-free, glassy-smooth surface ready for finishing. To achieve this kind of performance, you must maintain a sharp cutting burr on the scraper's edge. Fortunately, doing that requires only a pair of common tools. Here's how.

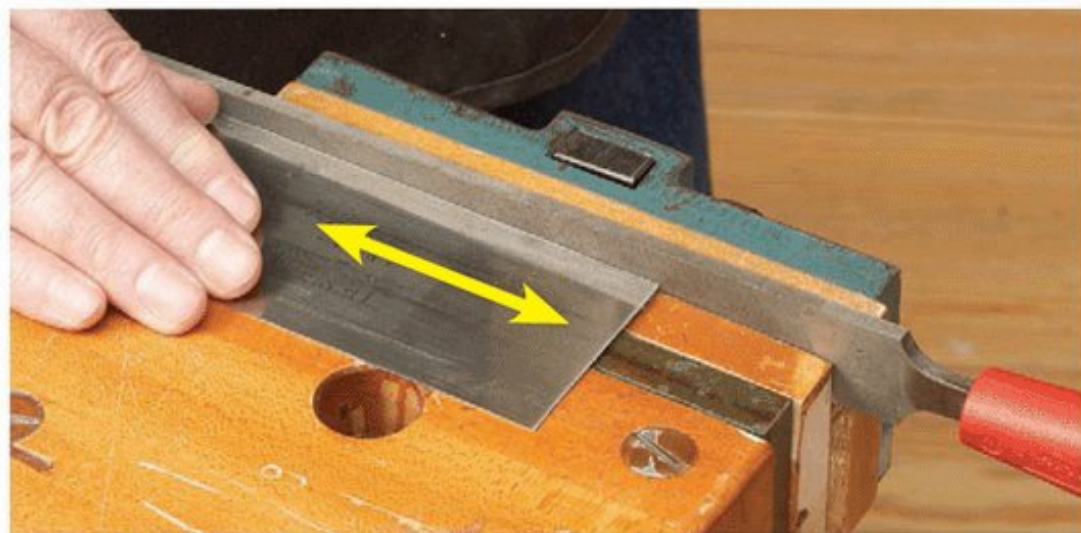

1 Select a mill file that's at least 3" longer than your scraper, and clamp it horizontally in a bench vise. With the scraper lying flat on the bench, slide it back and forth against the file until you've made the scraper's edge perfectly straight. Straighten the opposite edge, too.



2 Remove the rough burrs resulting from Step 1 by standing the scraper on edge and rubbing it back and forth a few strokes along the file. Do this for both faces on both edges; then remove the file from the vise.

■ Watch a FREE video on sharpening and using a scraper at woodmagazine.com/cardscraper.



3 Now clamp the scraper in the vise with about one-third of its width above the top of the jaws. Using a screwdriver with a hard, steel shaft, press down firmly while holding it perpendicular to the scraper face—parallel to the benchtop. Stroke back and forth until you can feel a burr forming on each side of the edge.

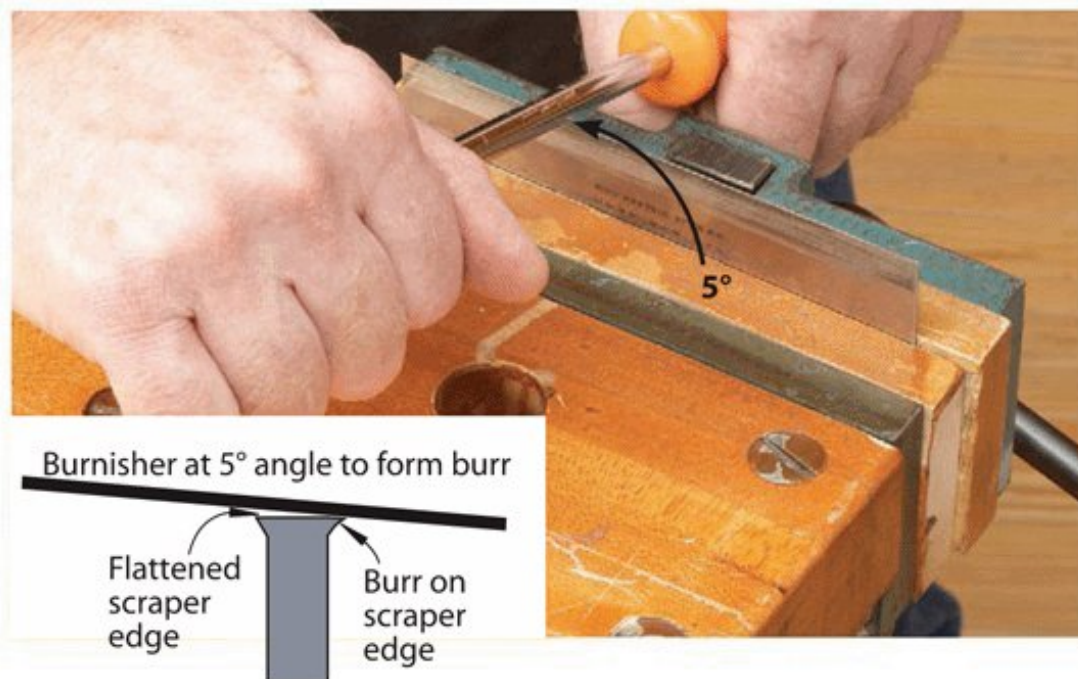

4 Next, tilt the screwdriver about 5° to one face. Repeat the process from Step 3 to further roll the burr, as shown in the illustration above, to give it a more aggressive cutting edge. Now tilt the screwdriver 5° to the opposite face, and repeat the process. Stop when you can feel a burr that's about equal to the other side.

5 To use the scraper, hold it with two fingers hooked around each end, and press into the back with your thumbs, bending the scraper slightly, as shown at top. Angle it forward and, when you feel the burr grab the wood, begin pushing forward while holding at that angle to produce light shavings. 🌲

How Do You Create Endless Cabinet Door Making Possibilities?



Profile Shown:
Round Over
(#99-760)



Patented design allows for multiple rail & stile project combinations



With Freud's New Premier Adjustable Rail & Stile System

Now with Freud's new, patented Premier Adjustable Rail and Stile router bit system, you are able to build any style of cabinet door in a wide range of door thicknesses and sizes! This extremely easy-to-use solution gives you unlimited creative freedom, and solves the long-standing limitations of existing frame and panel door construction.

This one of a kind solution allows you to create extended tenons for extra door joint strength, adjust groove width for different panel thicknesses and choose from a variety of material thicknesses for your stiles and rails (5/8" to 1-1/4"). Optional add-on cutters increase your bits' capabilities even more, allowing you to create glass panel and double sided profile doors.

Four profiles are available; **Round Over** (#99-760), **Ogee** (#99-761), **Round Over Bead** (#99-763), and **Bevel** (#99-764).



Standard stub tenons in regular 3/4" stock

Extended tenons for strong joints in larger doors

Glass & screen panel capability

Double Sided Profiles in thick stock



freud[®]
Precisely the best.

To find more information, please go to:

www.freudtools.com/PremierRailandStile

Others



VS



Freud's New Premier Rail & Stile System



Industry Standard Stub Tenons Joints

Industry Standard Stub Tenons Joints

Extended Tenons For Extra Strength

Adjustable Grooves For Variable Panel Thickness

Cabinet Doors In Varying Material Thickness

Glass/Screen Panel Doors

Double Sided Profile Doors

To sign up for Freud's e-mail newsletter or to find a dealer near you visit: www.freudtools.com

Red router bits are a registered trademark of Freud America, Inc. (US) 1-800-472-7307

www.WorldMags.net & www.Journal-Plaza.net

Why buy?

Mitersaws work hard in the shop and on a job site. Mounting the saw to a portable stand makes moving between the two locations easier. We tested stands for stability, portability, ease of setup and breakdown, and durability. Features we like include quick-release saw mounts that accept any model of saw and make it easy to position the saw anywhere along the rails; stops for cutting stock to identical length; and work supports that don't sag.

Portable Mittersaw Stands

We tested nine—these three made the final cut.

RIDGID AC9944, \$170



Editor test-drive:

I gave this sturdy stand a workout during the kitchen cabinet makeover in issue 196 (March 2010). I like the way the stand folds up with the saw attached to store on end, out of the way. That saved space for the homeowner when I finished for the day, and frees up usable square footage in a home shop. When it was time to work, the gas-strut-assisted lift helped raise the 94-lb. stand to working height. Quick-release mounts let me position the saw anywhere along the rail, but the 9944 still comes up a bit short in cut capacity: Maximum distance to a stop is 5'6". To

use a stop, you must raise the roller support, then lower it if the stop is no longer needed; not as handy as a flip-up stop. Those are my only gripes. The wide rail proved useful for corralling small parts or hand tools, the roller work supports don't sag, and the 12" wheels rolled over everything I put in their way, indoors and out.

To learn more:
866-539-1710; ridgid.com

—Tested by Kevin Boyle,
Senior Design Editor



DEWALT DW723, \$175



Editor test-drive:

Instead of wheels for portability, the DW723 weighs just 40 lbs; light enough to carry—if you remove the saw first. Fortunately, quick-release mounts make that easy to do. Flip the stand upside-down, press the spring-loaded catches, fold the legs neatly under the rail, and grab the handle to carry the stand to your next job.

The saw can be mounted anywhere along the rail, providing up to 8' of cut capacity to the flip-up stop on either of the work supports. And talk about reliable: I set the work supports level with my saw's table and they stayed at that

height no matter how far I extended the arms. Cam locks make quick work of locking an arm in position.

Although light in weight, this stand works like a heavyweight. It doesn't flinch when throwing 8' 4x4s onto it and provides a stable platform during cuts.

To learn more:
800-433-9258; dewalt.com

—Tested by Craig Ruegsegger,
Multimedia Editor



HTC PORTAMATE PM7000, \$249

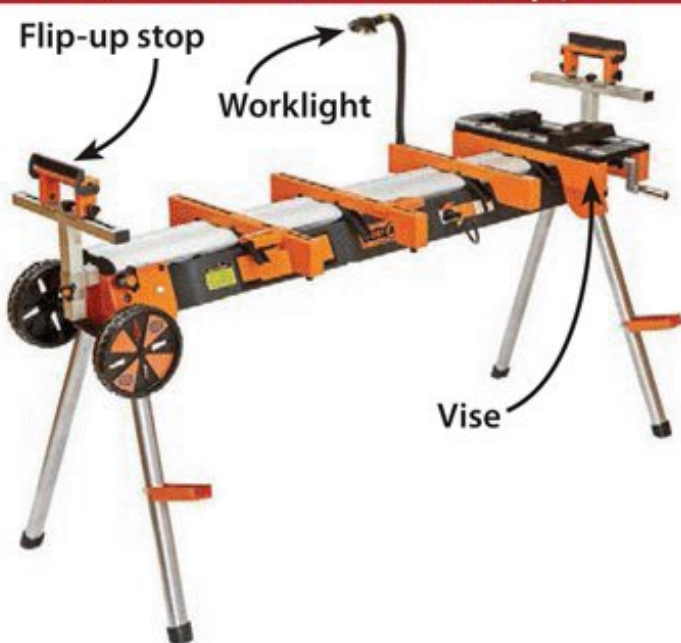

Editor test-drive:

Although the most expensive of the tested models, the PM7000 adds several nice features. Up front is a built-in power strip—handy for plugging in multiple tools and the included worklight. Also standard is a vise I'd rate as medium-duty. (In addition, Portamate sells an accessory router tabletop with fence for about \$125, and extra quick-release mounts for \$25 per pair for mounting benchtop tools.)

The legs brace the stand well, and the front legs sport a pair of fold-up brackets that hold a workpiece while you set up the saw or cut another piece. A small

storage compartment in the brace under the rail holds pencils, but not much more.

I found the plastic 8"-diameter wheels adequate, but too small and narrow for easy rolling over a rough job site. I also wish the handle was easier to grab when the stand is collapsed. 🌳

To learn more:
800-624-2027; portamate.com

—Tested by Jeff Mertz,
Design Editor



THE AMAZING Cyclone Rake®

Effortless Property Cleanup!

Hitch a Cyclone Rake to your mower and relax! Powerful engine-driven vacuum mulcher gives ten times the lifting power of mowers and many times the hauling capacity—up to 44 bushels in a single load. Lifts and pulverizes tons of debris and mows lawns clean as a fairway. Plus, it vacuums up the weed seed that mowers just scatter around. Best of all, it folds up flat for easy storage. Many models to fit every budget and property size.

Try it Risk-Free for All of 2010



CALL FOR **FREE** INFORMATION KIT **1-800-925-4617**
or visit www.CycloneRake.com

Prices starting at **\$995**

Mention the Discount Code **WM610** when you call, or enter it on our web site for a special discount on any Cyclone Rake unit.

Woodland Power Products, Inc., 72 Acton St., West Haven, CT 06516

A Deck you can be PROUD of.

- ✓ Lasts Longer
- ✓ Looks Better
- ✓ No Pop-Ups

How it Works

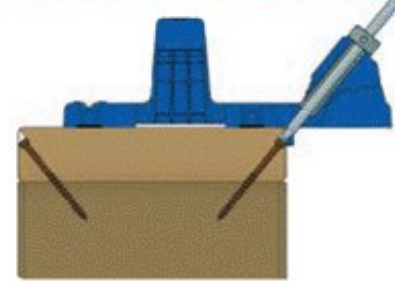

The Kreg Deck Jig™ guides your drill bit and self-tapping screw at a precise angle.



Watch the video and learn more at www.kregtool.com!

Using the same "Drill. Drive. Done!" technology built in to every Kreg Jig®, the all new Kreg Deck Jig™ can help you build a beautiful deck – free of exposed fasteners and painful splinters – in less time and with less frustration than you thought possible. Visit us online to get the whole story!

Other new products at www.kregtool.com



Square-Cut™
Cut with confidence.



Multi-Mark™
One tool does it all.



Crown-Pro™
Crown Molding made easy.



www.kregtool.com | 800.447.8638

Tricks for Treated

It's been seven years since the Environmental Protection Agency announced the phase-out of chromated-copper-arsenate (CCA) treated lumber over concerns that arsenic in the treatment was contaminating soil and children. CCA's replacements, although safer, bring different challenges to your outdoor projects. Here's what you need to know.

CA, ACQ, MCQ, Who?

Alkaline copper quaternary (ACQ) and copper azole (CA) accepted CCA's abdication of the outdoor-lumber throne with a fairly smooth transfer of power. Both treatments provide similar, high levels of preservative power with arsenic-free chemicals.

In order to achieve the preservative power of CCA, ACQ and CA ramp up the amount of copper used. But because copper speeds corrosion in ferrous metals, steel fasteners must be chosen with care. (See photo, *below*.)



The newest kid on the block, micronized copper quat (often marked MCQ) substitutes dissolved copper with a finely ground copper particulate. While it doesn't yet have the long, proven track record of ACQ and CA, proponents claim MCQ achieves the same level of wood preservation and rot-resistance with a lowered level of fastener corrosion.

Wet and warped

The new breeds of PT lumber still start out as stacks of Southern yellow pine placed into large, sealed vats where air is evacuated and the preservative chemicals are introduced. The low pressure draws the chemicals into the sapwood. Because there is little chance for it to dry between its chemical bath

and the time it hits the home-center shelves, PT lumber can have a moisture content percentage into the low-to-mid 20s. (Compare to kiln-dried hardwoods that average 6–8 percent.) Once left in

Are PT projects safe?

There's no need to run out and demolish that weathered pressure-treated (PT) deck for fear of arsenic leaching from older CCA-treated lumber. The majority of the leaching seems to happen in the first year.

But if it's time to replace the deck anyway, do take some precautions as you're working with both old and new PT lumber.

- Clean up and dispose of all debris through your municipality's trash collection. Never burn PT lumber: The smoke and ashes can contain toxic chemicals.

- Along with gloves and safety glasses, wear a dust mask when working with pressure-treated lumber to avoid inhalation of dust.

- Wash your hands or any exposed skin thoroughly after working with PT lumber.



FASTENERS FOR TODAY'S PRESSURE-TREATED WOODS

Hot-dipped galvanized



Hot-dip galvanized fasteners have a thicker zinc coating and therefore provide more rust resistance than fasteners galvanized by other means.

Stainless steel



Stainless-steel fasteners are nearly impervious to corrosion, but can cost twice as much as hot-dip galvanized.

Proprietary coatings



Some manufacturers use proprietary anti-corrosion layers. They are often color-matched to blend with the wood. Many offer a lifetime guarantee against corrosion.

Lumber Aisle

NEW LUMBER POOLING

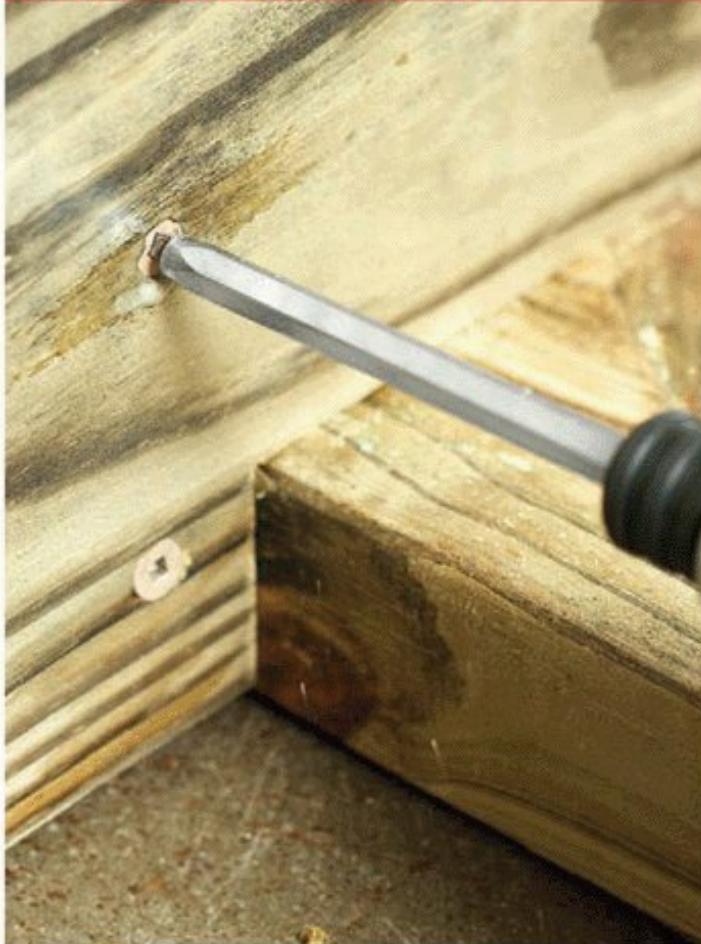

Some freshly pressure-treated lumber holds so much moisture that puddles form around the heads of driven fasteners.

your shop or a sunny spot, the drying—and the warping—begins.

The best approach to counter this: Let the wood acclimate outdoors in the shade for several weeks; then fasten it firmly in place with screws. One common mistake for beginning deck-builders is to leave a gap for drainage between the decking boards. This strategy isn't necessary for PT lumber; the shrinkage during drying will provide all the gap necessary.

But can I finish it?

PT lumbers' transformation to a weathered gray color is almost as inevitable as the sun and rain, primarily because it is caused by the sun and rain. Because there's no perfect finishing solution, you must choose either a durable finish that hides the wood grain or a lightweight finish that requires frequent reapplication.

Any outdoor finish heavy on pigments, such as paint or solid-color stains, provides the best protection against damaging UV light. Without those sun-screening pigments, clear, film-forming finishes, such as varnish and polyurethane, quickly slough off as the wood's surface degrades, *above*. Skip these clear or low-pigment finishes unless you enjoy refinishing every 6–12 months after a thorough sanding.

For a good compromise between the two, choose a penetrating-oil finish with finely ground, UV-inhibiting

OLD FINISH PEELING



Clear film finishes adhere only to the top layer of cells. When the wood sheds the sun-damaged cells, the film quickly sloughs off.

pigments, such as Penofin 550 (Performance Coatings, 800/736-6346, penofin.com); Ready Seal (Ready Products, 888/782-4648, readyseal.com); or Total Wood Preservative (Gemini Coatings, 800/262-5710, geminicoatings.com). The near-microscopic trans-oxide pigments effectively block most UV rays. You'll have to re-coat about every two years, but because you don't have to remove the previous finish, application is easy compared to other options. 🌳

EASY FINISHING OPTIONS



Oil-based, penetrating finishes combine a natural wood look with UV-protection and ease of application.

These outdoor alternatives put the pressure on PT lumber:

Strong pressure-treated wood resists decay and insect damage at a cost of about \$1 per lineal foot. But these alternative outdoor materials bring their own advantages to the backyard table.

Cedar

Pros: Lightweight, naturally decay-resistant

Cons: Requires replacement about every 10 years

Cost per lineal foot: \$1–2



White Oak

Pros: Dense and strong, moisture- and decay-resistant, accepts stains readily

Cons: Unavailable as dimensional deck lumber, pricey

Cost per lineal foot: \$2–3



Ipe

Pros: Super-dense, strong, and stable; resists warping, cracking, decay, and denting; life-expectancy of 40–50 years with proper care

Cons: Heavy, pricey, and sometimes hard-to-find

Cost per lineal foot: \$3–4



Wood/plastic composites

Pros: Rotproof, defect-free, and dimensionally stable; widely available in home centers

Cons: Not for structural applications, becomes hot to the touch in sunlight

Cost per lineal foot: \$2–3



Thermally-modified wood

Pros: Lightweight, stable, rot- and insect-resistant, chemical-free

Cons: Limited availability, split-prone

Cost per lineal foot: \$2



Made-in-the-shade Pergola



BASIC-BUILT™
GREAT PROJECTS MADE SIMPLE.

WHAT YOU'LL NEED



■ **Materials:** Dimensional pressure-treated lumber. (See "Working with Pressure-Treated Lumber" on page 32.)

PROJECT HIGHLIGHTS

- Overall dimensions: 11'1¼" x 11'1¼" x 8' high.
- Build subassemblies at ground level, then raise them into position.
- Stain beautifies pressure-treated lumber.
- Lattice screen provides privacy and serves as a trellis for climbing plants.

STAND UP STRAIGHT



A Brace the post (A) with kickers and stakes. Check for plumb in both directions before and after adding concrete to the hole.

TRIM THE FIRST POST TO LENGTH



B Screw a collar to the post (A) to guide your circular saw around all four sides of the post. Complete the cut with a handsaw.

SCRAPS GIVE ACCURATE MEASURES



C Clamp a 2×8 scrap to each post to represent the inside beams (B) when measuring for the length of the crossbeams (C).

Simple subassemblies with butt-together-and-screw joinery make this structure a breeze to build. After you set the posts in the ground, build subassemblies on-site or in your shop. Then just call a buddy to help lift them into place. (Be sure to promise some cool drinks in the pergola's shade when the job is done.)

Set the posts

Note: Call to have utility lines located before digging postholes. The post (A) length in the **Materials List** on page 41 allows for 36" below grade, the minimum for proper support of the pergola. Some areas may require longer posts to reach below the frost line. Check your local codes and adjust the hole depth and post length accordingly.

1 Start with posts (A) at least 6" longer than finished length. They will be cut to length after all four posts are set.

Note: If your site has a slope to it, remember to account for it by making the downhill posts longer. Rout ¼" round-overs on the

edges of each post [Drawing 1]. (The chamfers will be routed after the pergola is completed.)

2 Lay out the positions of the postholes on your site [Drawing 4]. (You can download an article to help with this at woodstore.net/bepostmaster.html for a small fee.) Dig the first 12"-diameter hole, add a 6" bed of gravel [Drawing 1], carefully set the post (A) plumb in both directions, and brace it [Photo A]. **Note:** The remaining posts will be set based on the first one, so take your time and get it perfectly plumb with the faces square to the site. Mix concrete and add it to the hole.

3 Dig the three remaining holes and add the gravel base. Cut an 85"-long spacer from scrap. Butt the spacer against the first post (A) to locate the two adjacent posts. After bracing these posts, use the spacer to locate the fourth post, measuring from the second and third posts. Double-check each post for plumb and the layout for square, then add concrete to the holes and allow it to set.

1 POSTHOLE DETAIL

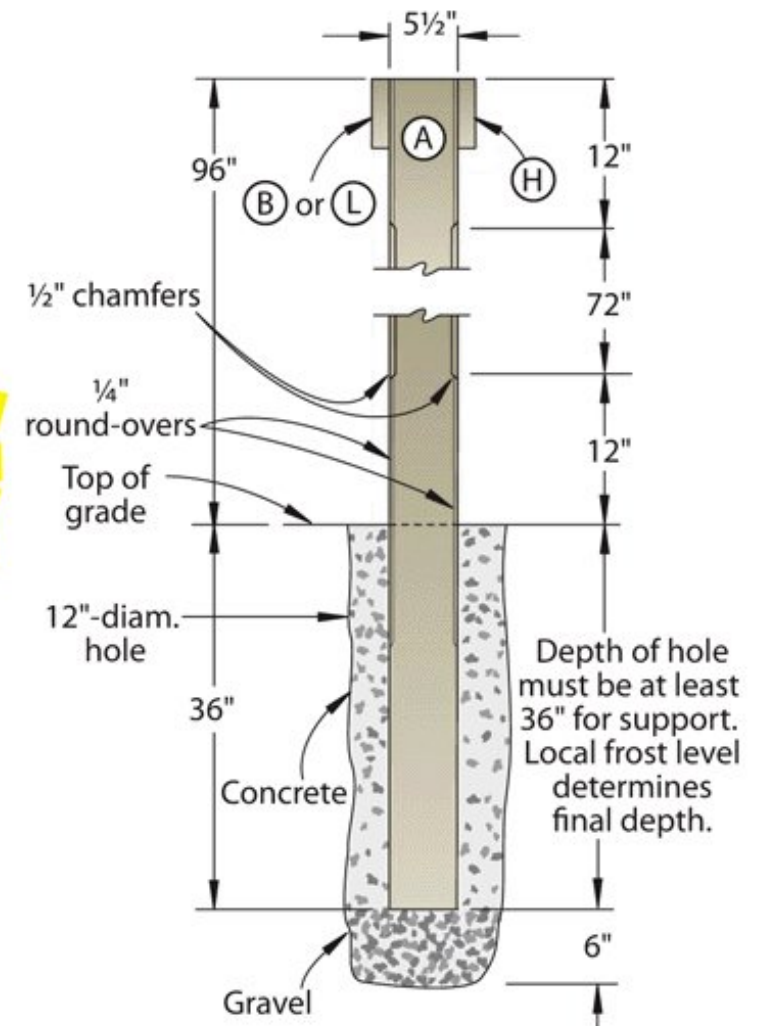

SHOP TIP

Working accurately with dimensional lumber

The thickness and width of dimensional or "2-by" lumber vary. For example, the posts on our pergola were ⅛" thicker and wider than their specified 5½×5½", and some 2×8s that should have been 7¼" wide were 7⅝". These little variations add up and may prevent internal parts from fitting properly between other parts. To get accurate measurements, use cutoffs from workpieces to mock up small assemblies. Clamp the mock-ups in place and measure between them to find the exact length of internal parts, right.



A 2x4 SCRAP KEEPS THINGS IN LINE

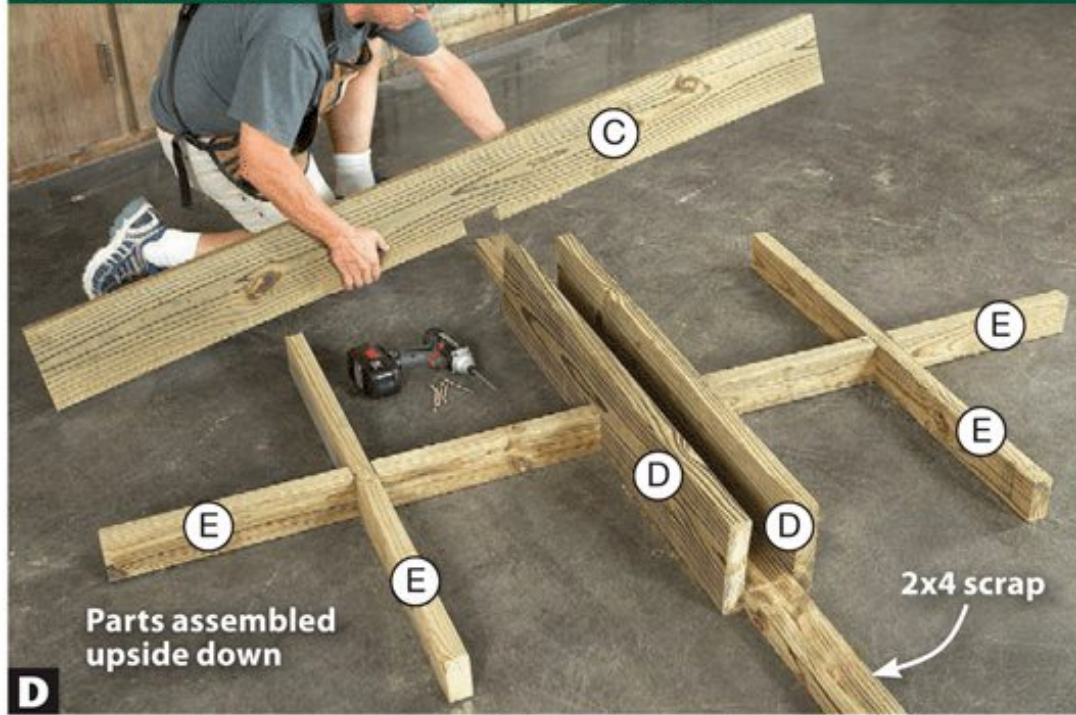

D Place a 2x4 between two assemblies of a short beam (D) and two grid rails (E). The notch in the crossbeam (C) fits over the 2x4.

ALIGN AND CONQUER



E A 2x4 in the notches aligns the crossbeams (C) and outside beam (H). Mark the locations of parts B-E on the four outside beams.

4 From scrap 2x4s, make five collars to fit around a post (A) [Photo B]. Set four of them aside for use during assembly of the pergola. Screw the fifth to the shortest post so your circular saw will cut the post at 8' above grade. Cut the top off the post. Then use a straight 8' 2x4 and a 4' level to transfer the 8' height to the remaining posts, and cut them to length. Remove the collar and save it.

Make the inside frames

1 Measure to the outside faces of the posts (A) to determine the lengths of the inside beams (B) [Drawing 2]. Measure as shown in Photo C to determine the length of the crossbeams (C). **Quick Tip! Stay grounded.** Take these measurements close to the ground to prevent errors caused by an out-of-plumb or bowed post. Cut the inside beams and crossbeams to length. Set the crossbeams aside for now.

2 Cut a centered notch on one edge of each inside beam (B) to accept the cross tie (N) [Drawings 2, 4]. (Watch a free video on circular-saw joinery at woodmagazine.com/circsawjoinery.) Retrieve the crossbeams (C) and cut a centered notch on one edge of them to accept the short cross ties (O).

3 Clamp cutoffs to an inside beam (B) [Shop Tip, page 35], and mark the length of the short beams (D) and grid rails (E) [Drawing 2]. Cut them to length.

4 Cut centered notches in the grid rails (E) to create a half-lap joint [Drawing 2]. Screw pairs of grid rails together to form crosses.

5 Assemble the inside frames by positioning a short beam (D) and a grid rail (E) upside down on a large flat surface [Photo D]. Center the grid rail on the short beam's length and screw the beam to the rail. Do this for the remaining

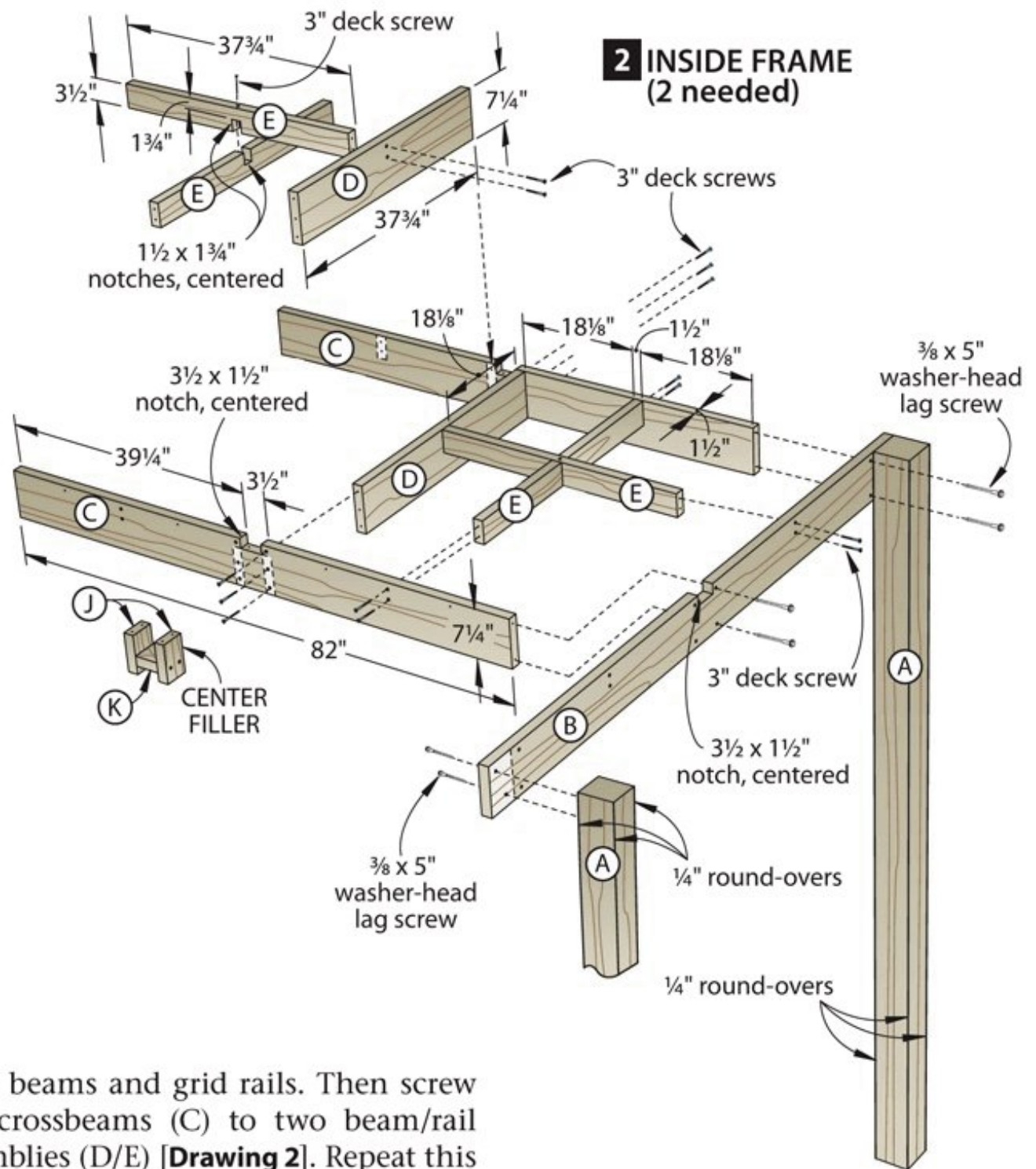

short beams and grid rails. Then screw two crossbeams (C) to two beam/rail assemblies (D/E) [Drawing 2]. Repeat this process to make two inside frames.

Now, the outside frames

1 Cut the beam extensions (F) and grid extensions (G) to length [Drawing 3]. Add 17 1/2" to the distance from outside to outside of the posts and then cut the outside beams (H) to this length. Lay out and cut the arch on one beam extension [Drawing 3a], then use this piece to lay out the arch on the remaining beam extensions and outside beams. Using your jigsaw, cut out all of the arches.

2 As shown in Photo E, arrange two cutoffs from a post (A), an inside beam (B), one inside frame (C-E), an outside beam (H), five beam extensions (F), and two grid extensions (G). Transfer the locations of the grid rails (E), inside beams, and outside face of the post to the outside beam. Repeat this process for the remaining three outside beams, marking the crossbeam (C) locations as well. Transfer these layout lines down the outside faces of the outside beams

COLLARS LEND A HAND

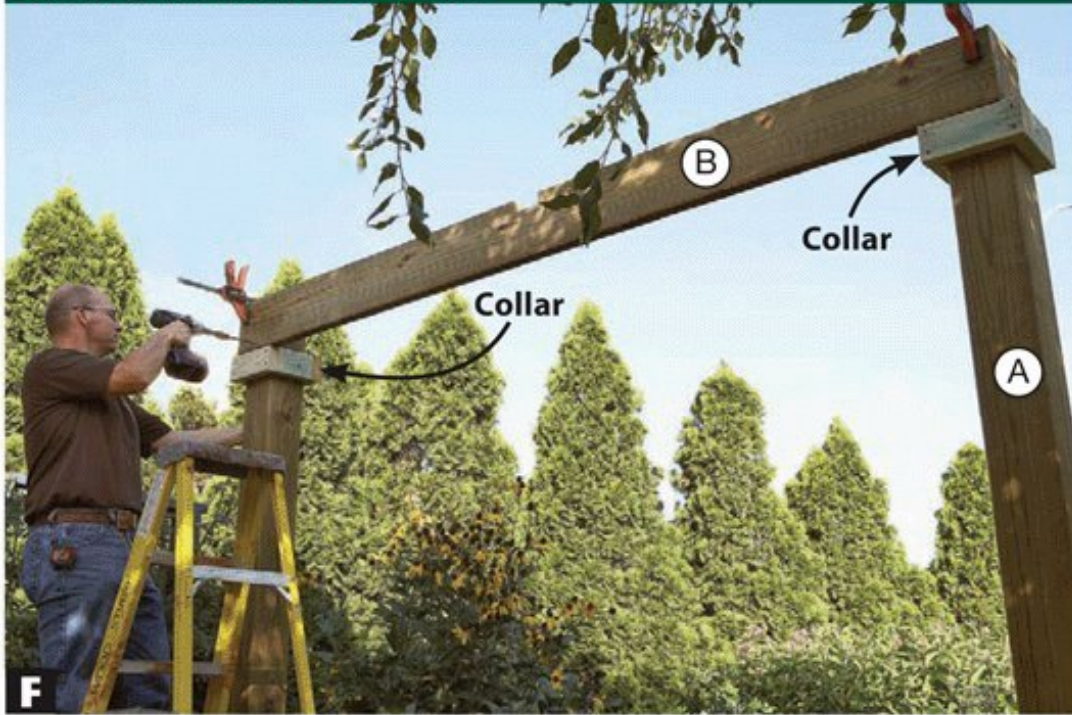

F Screw a collar to each post (A) so the inside beams (B) sit flush with the top of the posts. Drill $\frac{1}{4}$ " pilot holes for the lag screws.

CREATE A SUPPORT GROUP

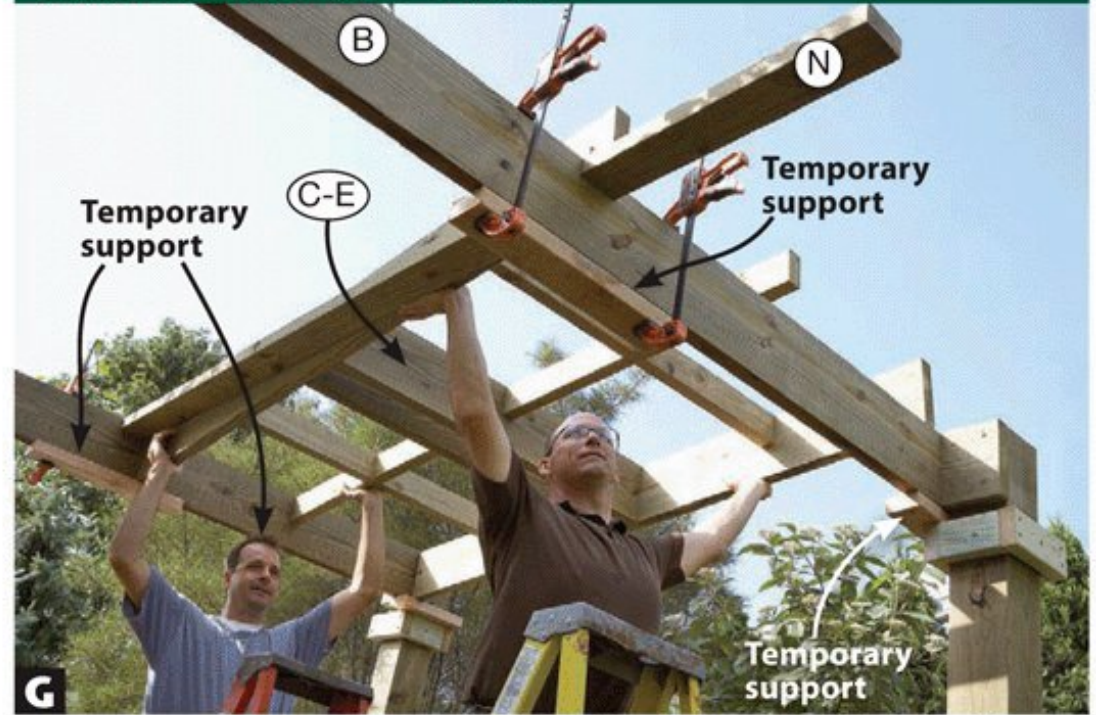

G Create temporary supports for the inside frames (C-E) by securing scraps below the inside beams (B) to create a lip.

3 OUTSIDE FRAME (4 needed)

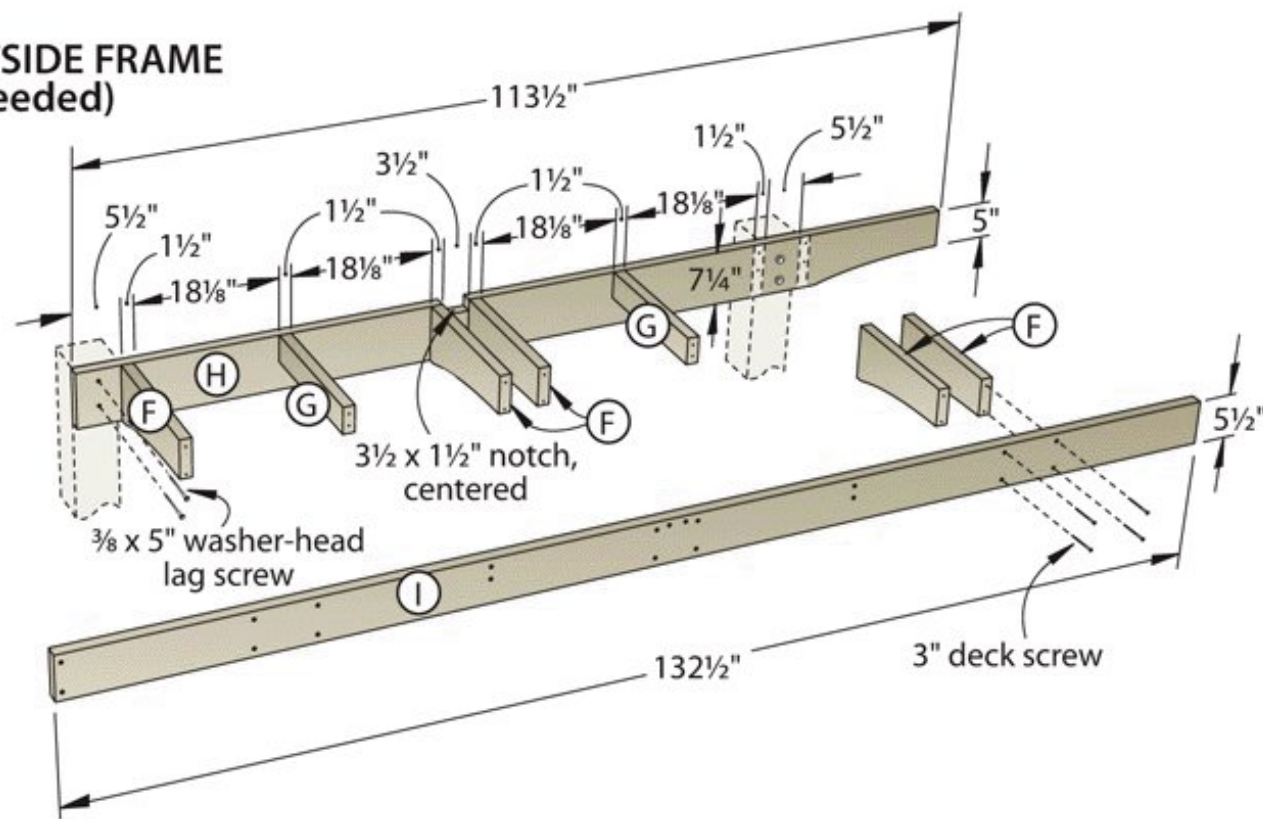

and screw the beam extensions and grid extensions in place along these marks.

3 Cut the bands (I) $36\frac{1}{2}$ " longer than the distance from outside to outside of the posts (A). Align one end of each band flush with the cutout end of an outside beam (H) and screw the band to the extensions (F, G).

4 Cut the center filler sides (J), center filler (K), beam filler sides (L), and beam fillers (M) to size [Drawings 4a, 4b]. Assemble the center filler and four beam fillers as shown, then set them aside. The four leftover beam filler sides will be used later along one side of each post (A) [Drawing 4].

3a BEAM ARCH DETAIL

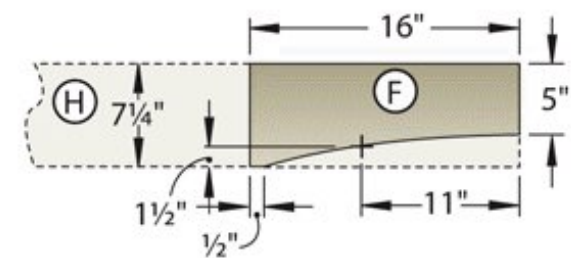

Installing the frames

1 Retrieve four of the collars you made earlier and, using a scrap of 2×8 as a gauge, attach one to each post (A) [Photo F]. Attach the inside beams (B) with $\frac{3}{8} \times 5$ " washer-head lag screws.

2 Cut the cross tie (N) to length to equal the distance between the outside faces of the posts (A) plus 35" [Drawing 4]. Center the cross tie over the inside beams (B) and secure one end with a 3" deck screw into an inside beam.

3 Reposition the collars, securing a scrap 2×4 support block between the collar and inside beam (B); this helps support the inside frames (C-E) as they are installed [Photo G]. Center scrap 2×4 s

SECURE THE INNER FRAMES

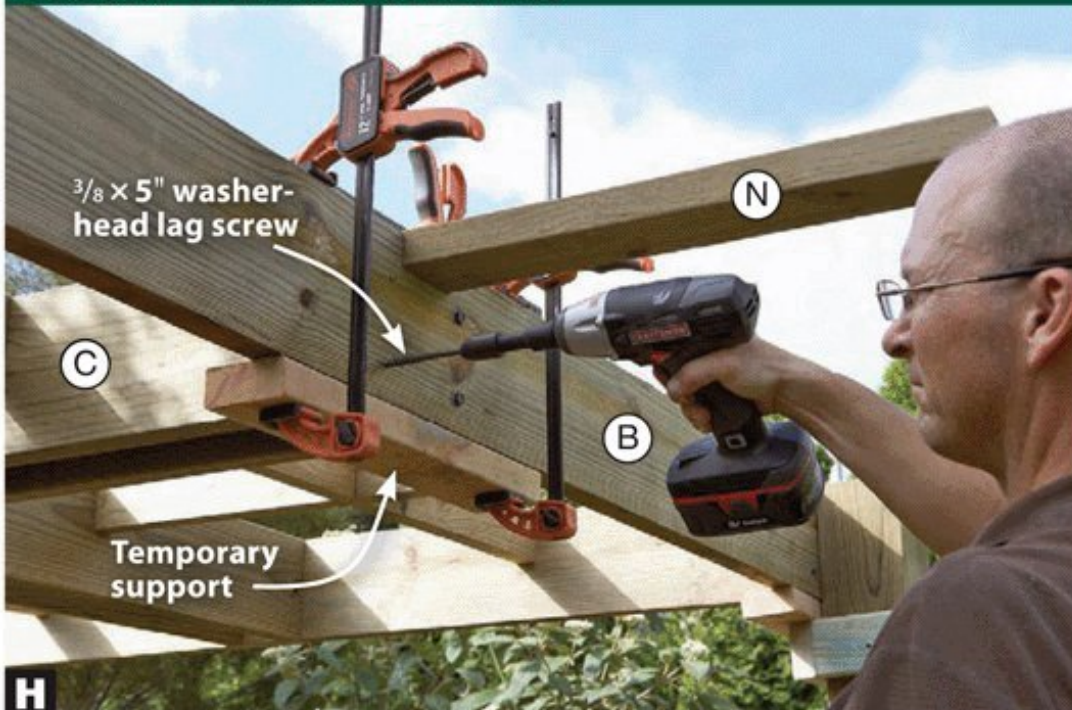

H Drill pilot holes, then drive lag screws into the ends of the crossbeams (C) and 3" deck screws into the grid rails (E).

ATTACH THE CROSS TIES

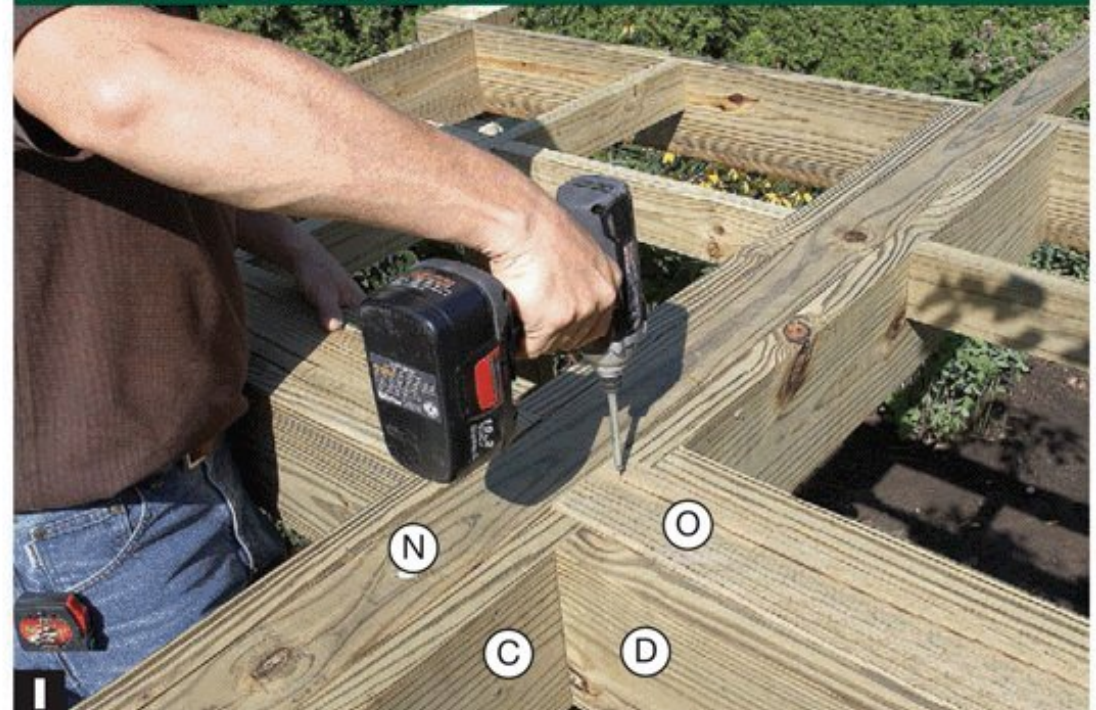

I Secure the loose end of the cross tie (N) with 3" deck screws. Then screw the short cross ties (O) to the crossbeams (C).

A GOOD SMACK MARKS THE LAG-SCREW LOCATIONS



J Straddle the cross ties (N, O) with a beam filler (L/M). Strike the filler sides to mark the locations of the lag-screw heads.

DRILL RELIEF HOLES FOR THE LAG-SCREW HEADS

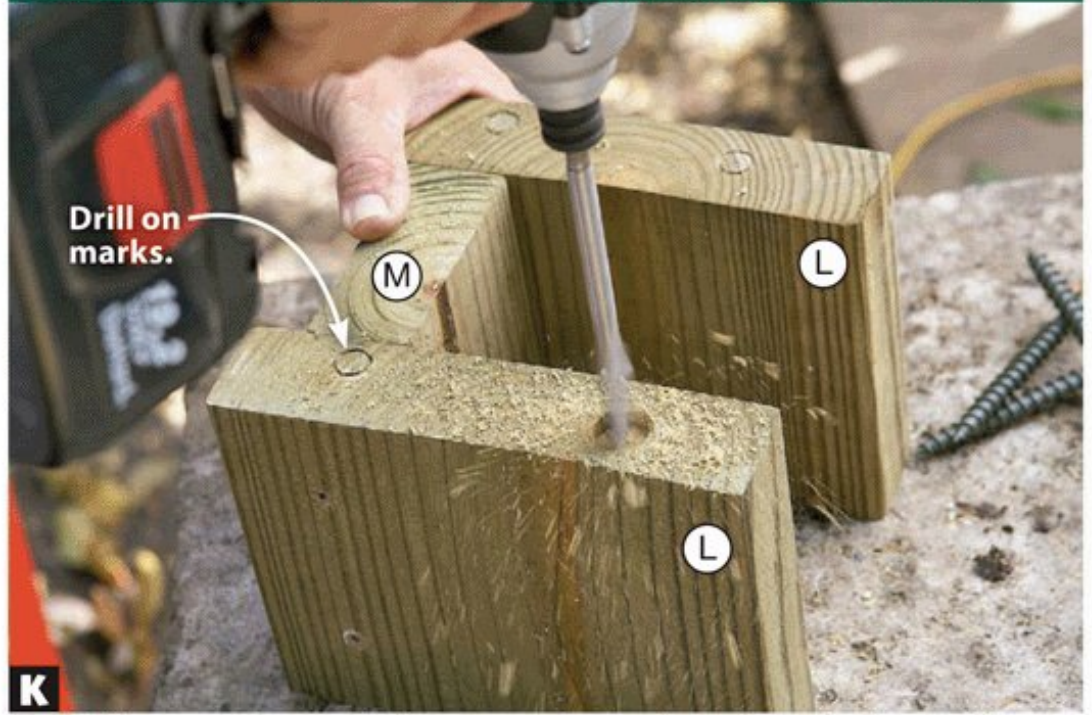

K Drill $\frac{3}{4}$ " counterbores $\frac{3}{8}$ " deep at each mark to allow the beam fillers (L/M) to fit over the lag-screw heads and tight to the beams (B, C).

on the bottom of each inside beam and clamp them in place. Position both inside frames, drill pilot holes for the lag screws, and secure the inside frames [Photo H]. Screw the crossbeams (C) to the cross tie (N), then cut the short cross ties (O) and screw them in place [Photo I, Drawing 4].

4 From below, position the center filler (J/K) and screw it in place [Drawing 2]. Place each beam filler (L/M) in position and strike it with a mallet to mark the locations of the lag-screw heads [Photo J]. Drill counterbores at these marks [Photo K], then screw through the beam filler sides (L) into the cross ties (N, O). Use the same procedure to mark and drill counterbores on the four remaining beam filler sides (L). Screw them to the posts (A) [Drawing 4].

5 Reposition the support blocks above the collars on the outside faces of the posts (A). With help from a friend, clamp an outside frame (F-I) to the posts so it rests on the support blocks [Photo L]. Lag-screw the outside beam (H) to the posts, then work around the structure attaching the remaining outside frames [Drawing 5]. Use clamps to help align the bands (I); drive 3" deck screws at each corner [Photo M].

6 Cut the trim (P) to length from treated 1x4s and screw it to the bands (I) [Drawing 5].

7 Reposition the collars against the bottom edges of the inside beams (B) and crossbeams (C). Retrieve the remaining 2x4 collar and secure it to a post, with its top edge 10" above grade. Rout a $\frac{1}{2}$ " chamfer between the collars [Photo N]. Repeat this process to chamfer all four corners of each post [Drawing 1], then remove the collars.

4 INSIDE FRAME INSTALLATION

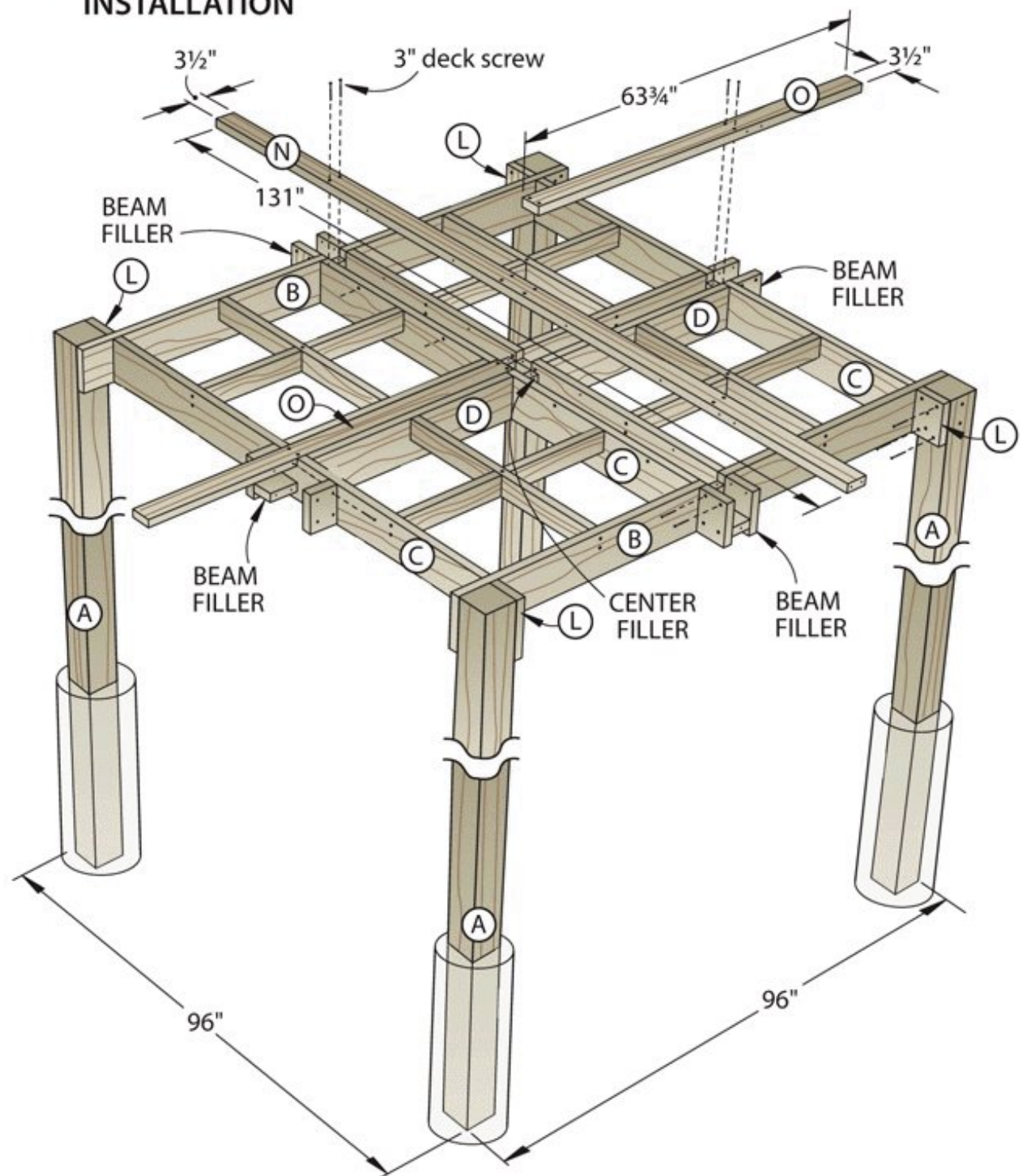

4a CENTER FILLER

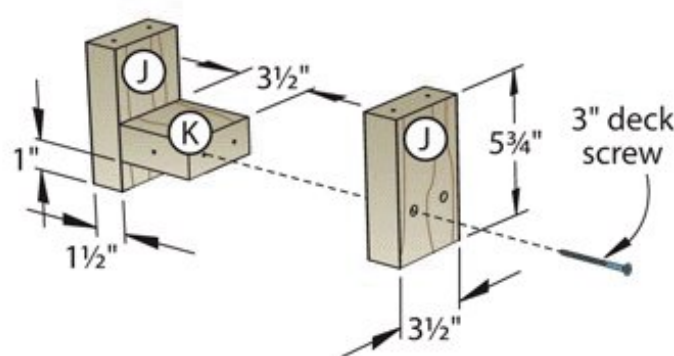

4b BEAM FILLER (4 required)

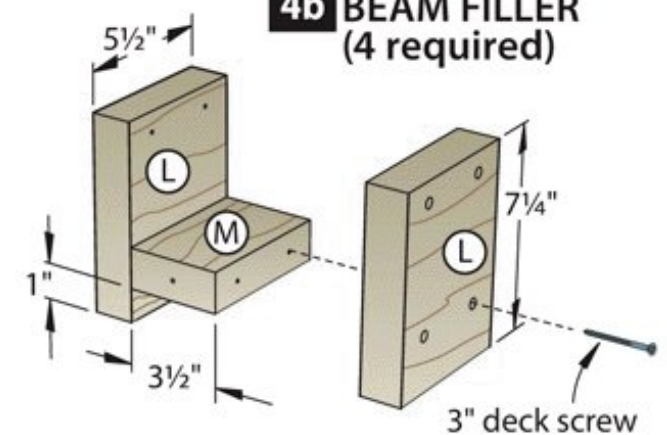

ATTACH THE OUTSIDE FRAMES



L Position the end of the outside beam (H) flush with the outside face of the post (A). Drill pilot holes and drive lag screws.

TIE THE CORNERS TOGETHER



M Bringing the bands (I) together at the corners may require using clamps and spreaders to align the pieces.

Add a screen

1 Measure between two posts (A) and subtract the width of the screen post (X) [Drawing 7]. Cut two tops and two bottoms (Q) to one-half of this dimension [Drawing 6]. Rip them to width, and set them aside. Cut the uprights (R) and long rails (S) to size and set four uprights aside. Screw the remaining uprights and long rails together to make two frames.

2 From 1×4 stock, rip the vertical slats (T) and horizontal slats (U) to width, then crosscut them to fit inside the frames (R/S). Cut spacers from scrap to help position the slats [Photo O]. Secure the slats with screws driven through the uprights, rails, and every other slat intersection [Drawing 6].

3 Retrieve the tops and bottoms (Q), center two of them on the width of

CHAMFER THE POSTS

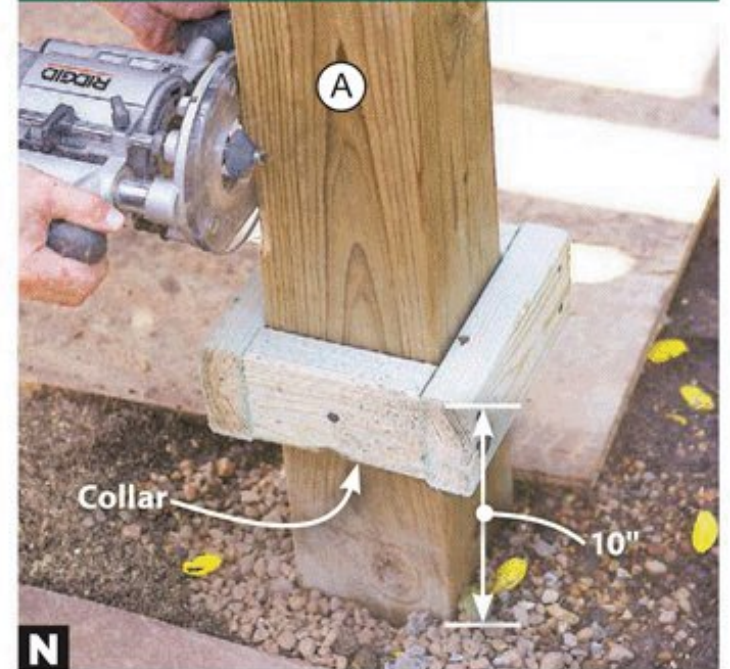

N Starting with the base of your router against the lower collar, rout a ½" chamfer until the router base contacts the upper collar.

5 EXPLODED VIEW

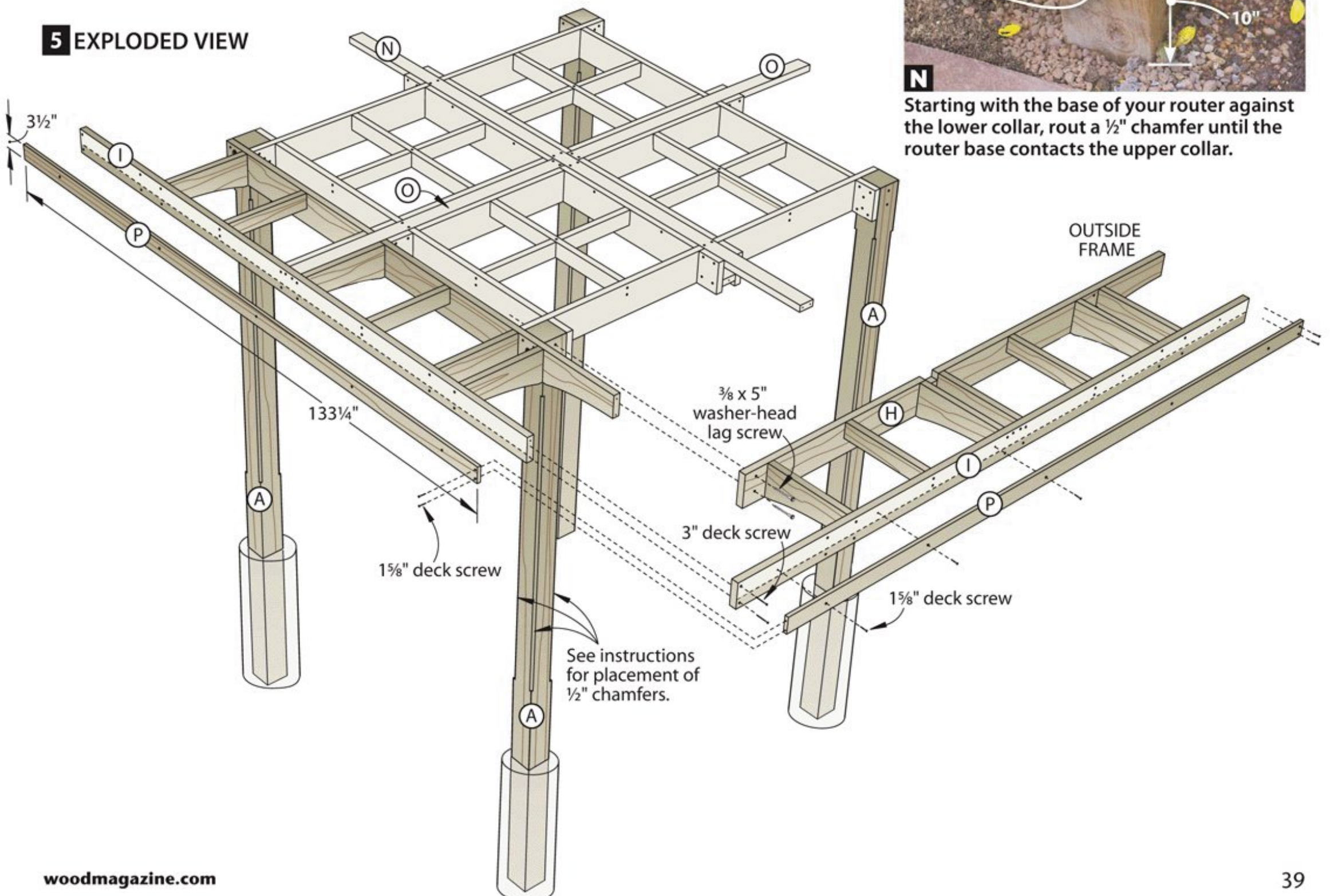

SPACERS MAKE FOR AN EVEN LATTICE

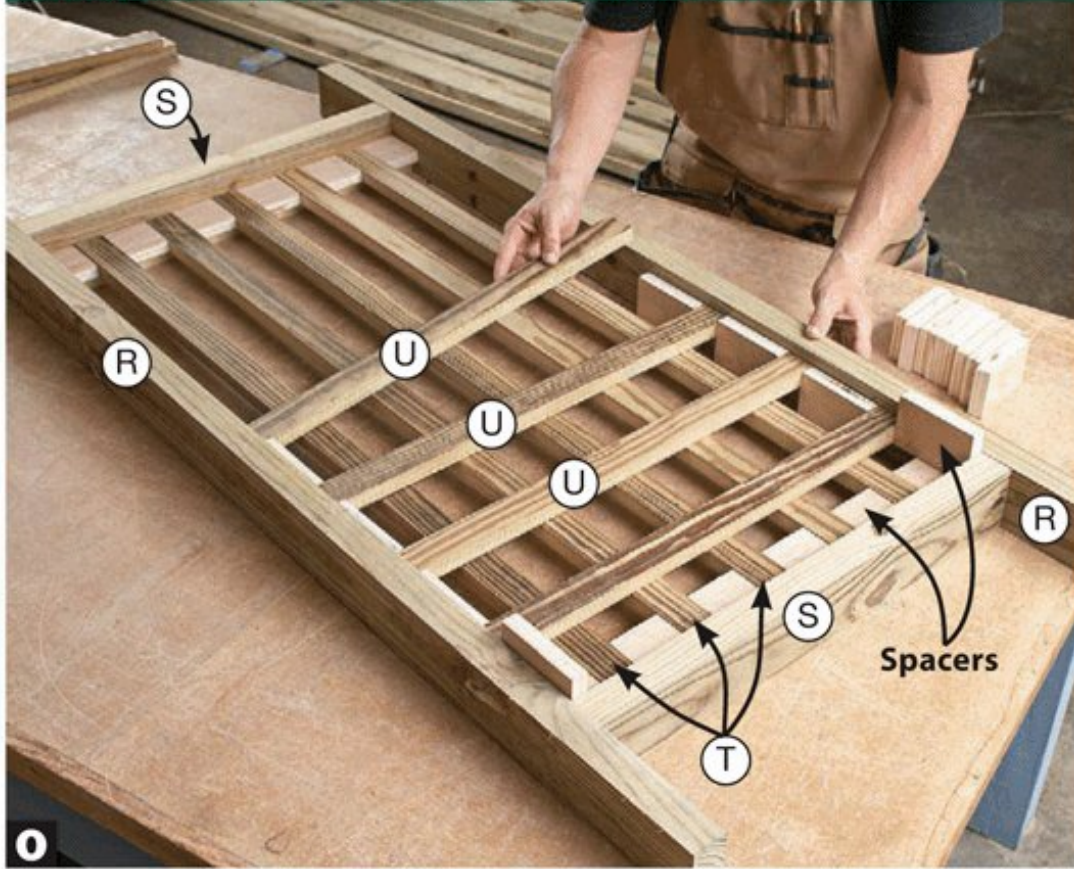

O Rest the vertical slats (T) on $\frac{3}{4}$ "-thick scrap to center them in the frame, then place spacers to position the slats (T, U).

A SCREEN HELPS YOU POSITION THE POST



P Clamp the screen post (X) to the upright (R). Screw the upright to the post, then screw the remaining screen (Q-V) in place.

each screen assembly (R-U), and screw them to the uprights (R) [Drawing 6]. Screw the remaining uprights between the tops and bottoms, flush with their ends. Near the top of the assembly, measure between two uprights to find the length of the short rails (V). Cut them to size and screw them in place.

4 Prepare a posthole centered between two posts (A). Crosscut the cap (W) to fit between the posts [Drawing 7], rip it to width, and rout $\frac{1}{2}$ " chamfers along the top two long edges [Drawing 7a]. Screw the cap to the posts 72" above grade, making sure it is level. Screw a screen (Q-V) to a post and the cap. Cut the screen post (X) to length, rout $\frac{1}{4}$ "

round-overs on the long edges, and clamp it to the screen [Photo P]. Check the fit of the remaining screen, then screw it to the post and cap. Pour concrete in the hole.

5 Treated lumber is very wet, so we allowed our pergola to dry for 30 days

before applying a finish. (We brushed and rolled on Thompson's WaterSeal Barkwood and Natural Almond oil-based deck and house stains.)

Produced by **Craig Rueggeger** with **Jeff Mertz**
Project design: **Jeff Mertz**
Illustrations: **Roxanne LeMoine; Lorna Johnson**

6 SCREEN PANEL

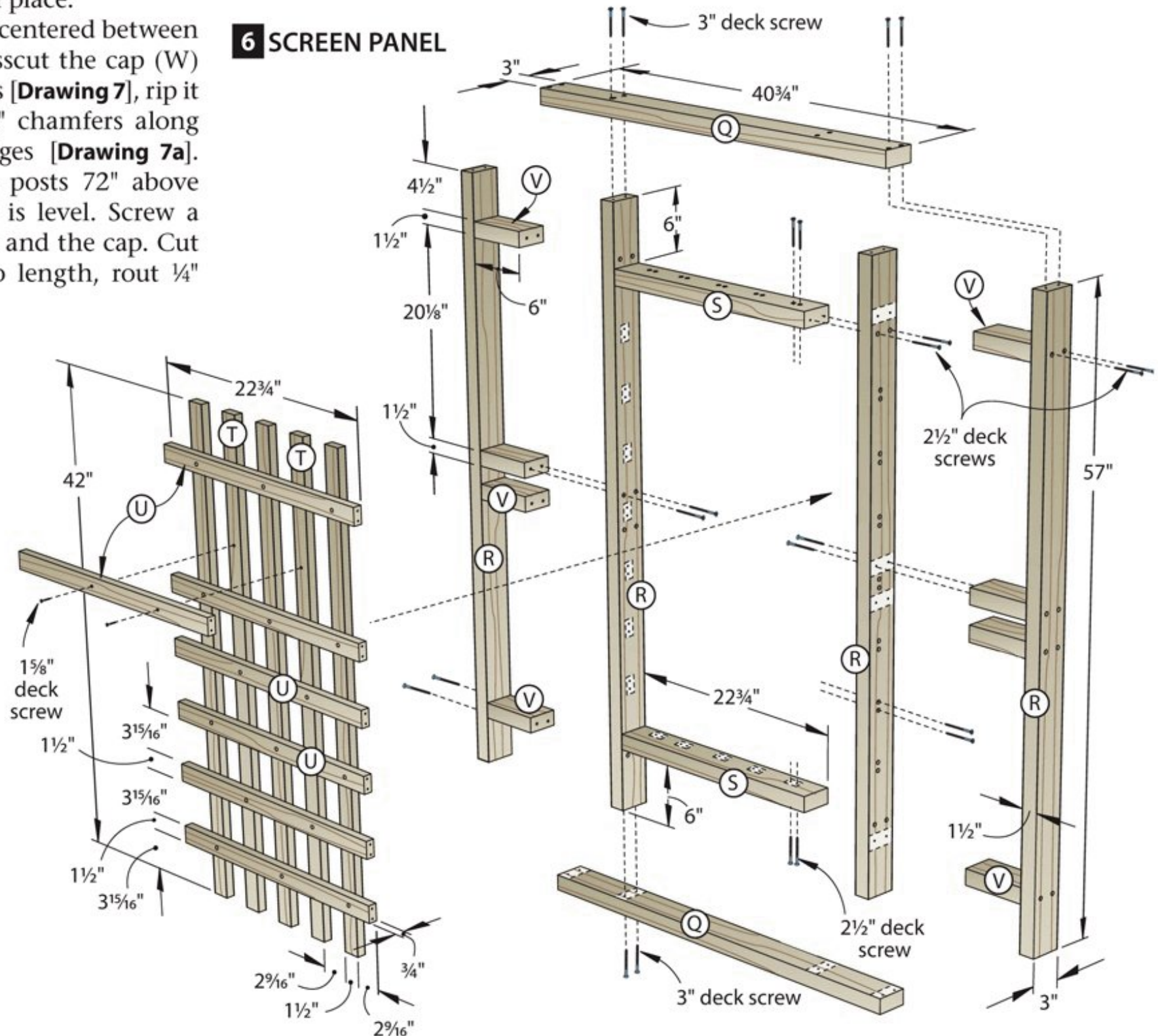

7 SCREEN OPTION

7a SCREEN CAP END VIEW

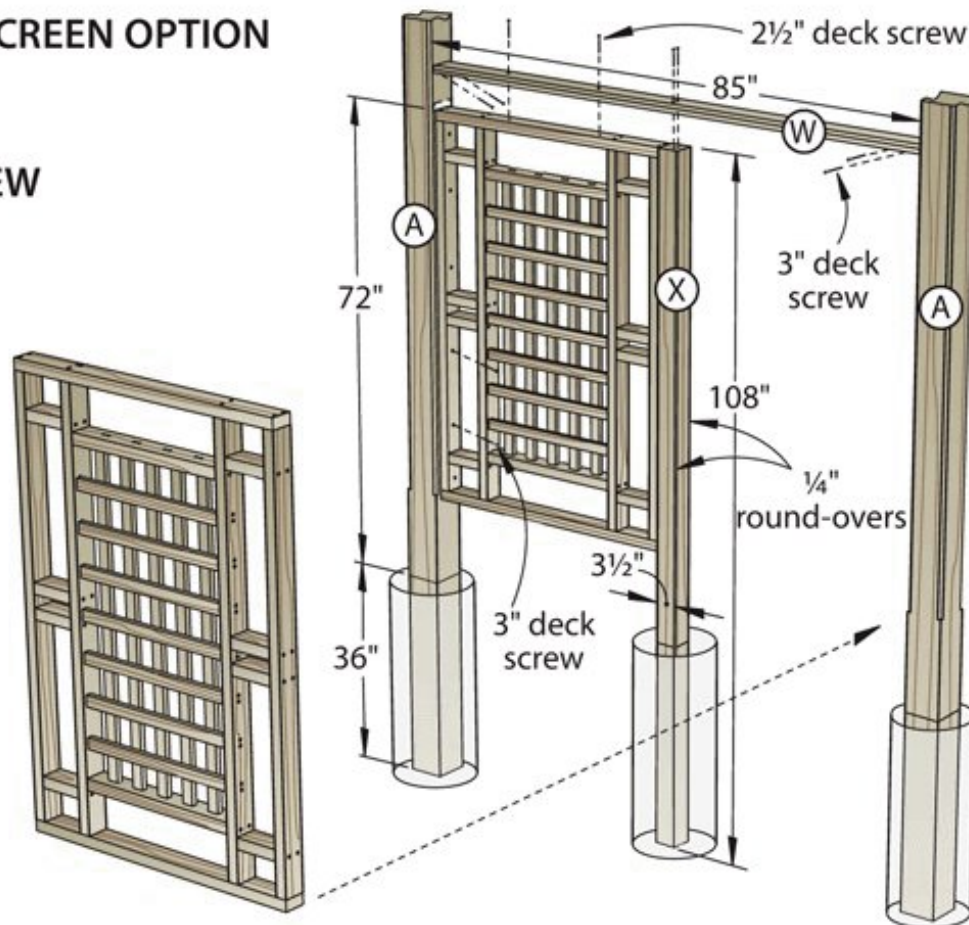
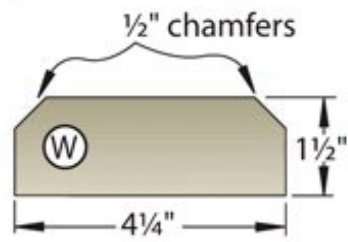

If you would like to build a freestanding matching privacy screen/trellis like the one above, visit woodmagazine.com/screen for the free plan.

Cutting Diagram

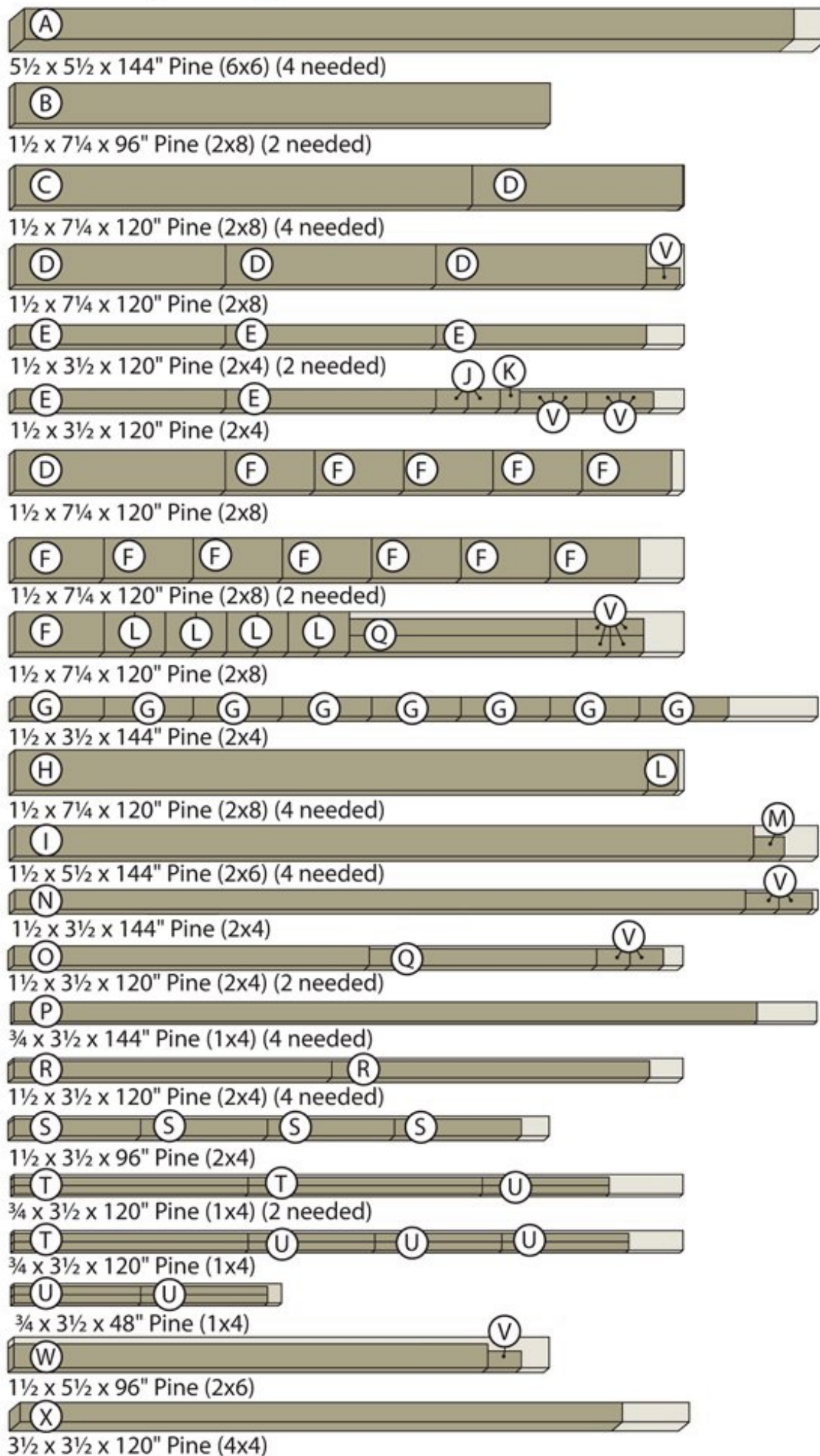

Materials List

Part	FINISHED SIZE			Matl.	Qty.
	T	W	L		
A* posts	5 1/2"	5 1/2"	132"	T	4
Inner frames					
B inside beams	1 1/2"	7 1/4"	96"	T	2
C crossbeams	1 1/2"	7 1/4"	82"	T	4
D short beams	1 1/2"	7 1/4"	37 3/4"	T	8
E grid rails	1 1/2"	3 1/2"	37 3/4"	T	8
Outer frames					
F beam extensions	1 1/2"	7 1/4"	16"	T	20
G grid extensions	1 1/2"	3 1/2"	16"	T	8
H outside beams	1 1/2"	7 1/4"	113 1/2"	T	4
I bands	1 1/2"	5 1/2"	132 1/2"	T	4
Fillers					
J center filler sides	1 1/2"	3 1/2"	5 3/4"	T	2
K center filler	1 1/2"	3 1/2"	3 1/2"	T	1
L beam filler sides	1 1/2"	7 1/4"	5 1/2"	T	12
M beam fillers	1 1/2"	3 1/2"	5 1/2"	T	4
Cross ties and trim					
N cross tie	1 1/2"	3 1/2"	131"	T	1
O short cross ties	1 1/2"	3 1/2"	63 3/4"	T	2
P trim	3/4"	3 1/2"	133 1/4"	T	4
Screen					
Q tops/bottoms	1 1/2"	3"	40 3/4"	T	4
R uprights	1 1/2"	3"	57"	T	8
S long rails	1 1/2"	3"	22 3/4"	T	4
T vertical slats	3/4"	1 1/2"	42"	T	10
U horizontal slats	3/4"	1 1/2"	22 3/4"	T	14
V short rails	1 1/2"	3"	6"	T	16
W cap	1 1/2"	4 1/4"	85"	T	1
X* screen post	3 1/2"	3 1/2"	108"	T	1

*Length depends on local codes. See the instructions.

Material key: T-Pressure-treated lumber.

Supplies: 3/8 x 5" washer-head lag screws (32), 1 1/8" deck screws (64), 2 1/2" deck screws (94), 3" deck screws (312), gravel, concrete mix.

Bits: 3/4" spade drill bit; 1/4" round-over, 45° chamfer router bits.

Five-Minute Face Frames



Pocket-hole joints provide the perfect combination of speed and strength for this job.

ANATOMY OF A POCKET-HOLE JOINT

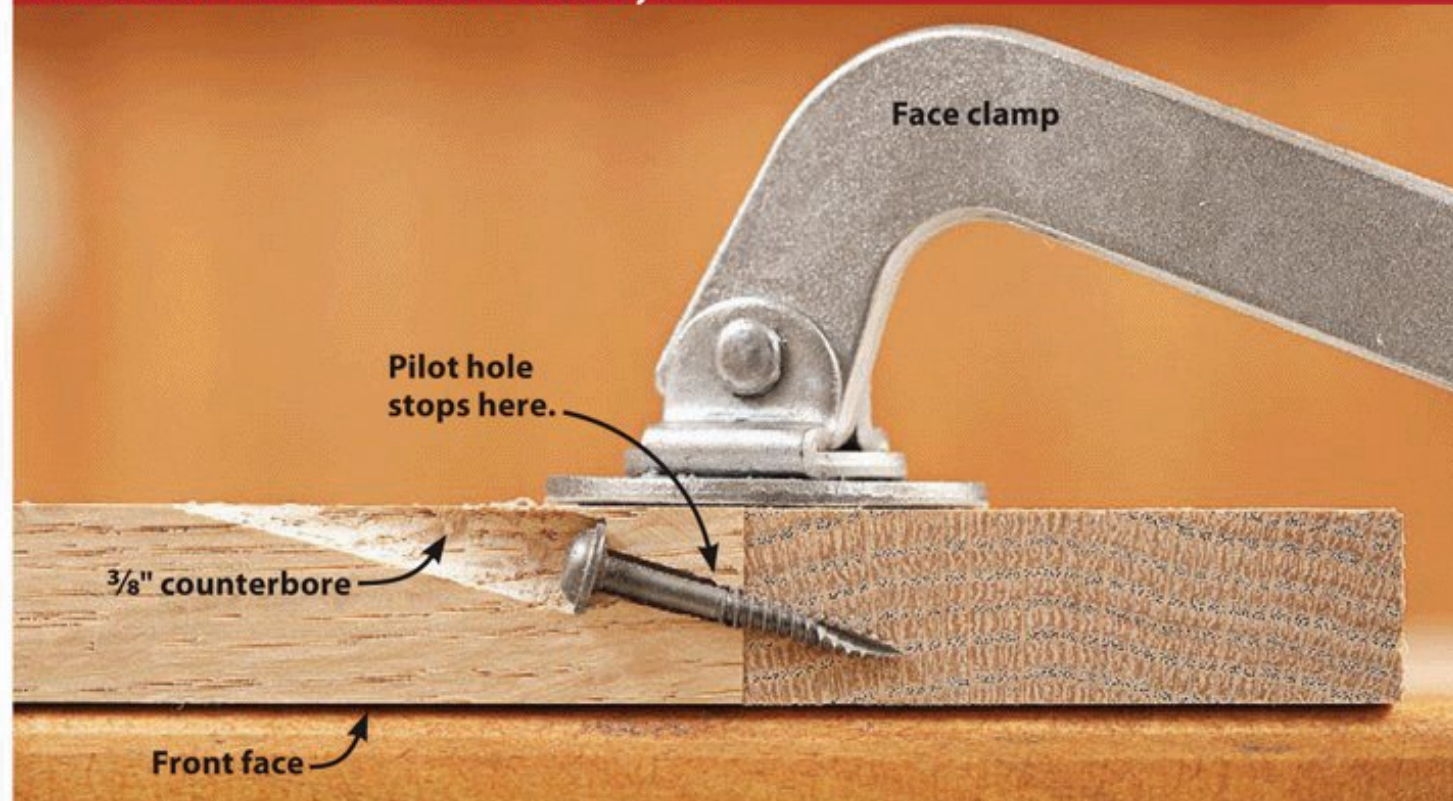

In a correctly drilled pocket hole, the pilot hole should stop $\frac{1}{8}$ " from the end of the workpiece. Because the smooth screw shaft turns freely within the pilot hole, the screw threads pull the joint tightly together.

When it comes to assembling face-frames for cabinets, there's nothing faster than pocket-hole joints—each joint takes about 90 seconds apiece using a store-bought jig. Attaching the frame to the case hides the holes.

Pocket-hole screws give the frame all the strength it needs and then some. The angled screws cut across grain rings instead of only passing straight through the weaker end grain, making the joint tougher to pull apart.

The mechanical advantage of the screws makes these joints so strong, you can skip gluing the joints for face-frames. That's a big plus if you plan to stain the frame and don't want to bother sanding away glue smears.

Here's how to make pocket-hole joints as easy as 1-2-3.

1 Mark an "X" on the inside faces of each frame part to avoid drilling into the appearance face of your frame. Center the pocket-hole jig on the end of a part to be drilled and clamp both firmly to your workbench.

2 Set the drill bit stop collar according to workpiece thickness and the type of jig you're using. Then drill two pocket holes [Photo A]. Repeat the first two steps for the ends of each rail and center stile on your frame.

3 At each joint, butt the mating parts together and clamp them solidly against your workbench [Photo B]. Then drive pocket-hole screws suited to the wood. Use fine-thread screws for joining hardwoods and coarse-thread screws for softwoods and composites, such as MDF or particleboard. Both types have split tips that eliminate the need to drill pilot holes in the part being joined.

DRILL STEPPED HOLES



A Visually center the jig on the end of your workpiece. Then drill pilot holes in pairs to keep parts from twisting.

CLAMP AND SCREW PARTS

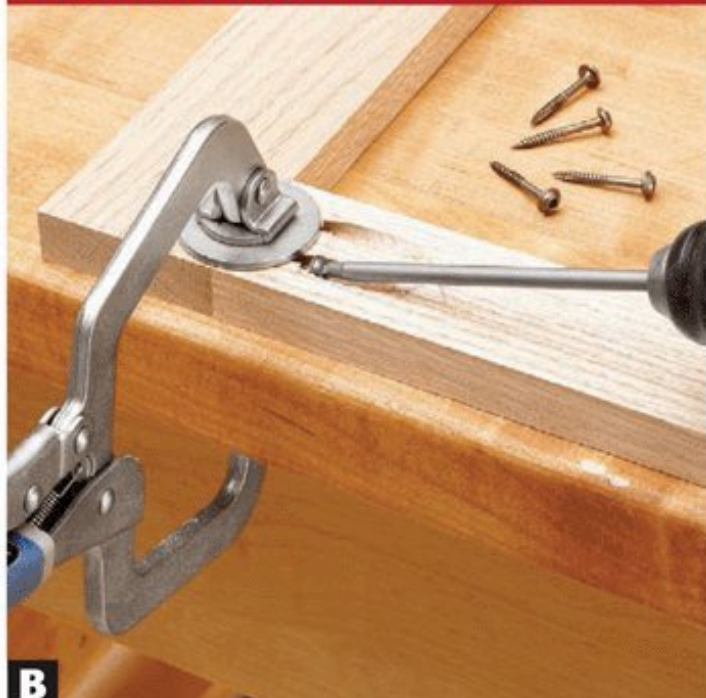

B Position the face clamp to span both joint parts. Self-tapping screws keep the mating part from splitting.

Avoiding mistakes is easy, too

Pocket-hole joints come close to being foolproof, but a few simple tips ensure perfect joints every time.

- Driving screws can push parts away from each other, as shown *below*, if both aren't clamped firmly in place.
- To avoid drilling through your workpiece, double-check the stop-collar setting using scrap stock identical in thickness to your workpieces.
- Too much drill torque can break loose the material between the bottom of the pocket-hole and the workpiece end.

Dial down the torque setting on your drill-driver before you begin; then dial it up until it just seats the screw.

- Use specially designed screws designed for pocket-hole joints. The bugle-shaped head of a flathead or drywall screw can split the wood at the bottom of the pocket-hole.
- Does your bit look new but work like it's old and dull? Check that the chuck turns clockwise, not counterclockwise. (Yes, it happens.)

CLAMP FIRMLY FOR A SOLID JOINT



Driving the screw separates a poorly clamped joint, throwing off the part alignment even if the screw pulls the joint back together.

PRE-CUT PLUGS NEED A TRIM



C Wooden pocket-hole plugs still need to be sanded flush with the surface. For a similar look, use $\frac{3}{8}$ " dowels.

MELAMINE PLUGS POP IN PLACE



D Molded plugs hide the pocket hole and chip-out from drilling. You also can buy plugs to match black, brown, and almond melamine.

Plug or no plug?

Your case edges should hide the pocket holes after you attach the face frame, but you may want to further conceal the holes from view on some projects. In wood, fill the holes with pre-cut plugs or $\frac{3}{8}$ " dowels of the same species. With either one, trim off the excess after the

glue dries and hand-sand them flush with the workpiece [Photo C] using a rigid-backed sanding block. Or turn plugs into accents using contrasting species, such as a walnut plug in maple.

For melamine-coated particleboard projects, use angled plugs molded to snap into the pocket hole [Photo D].

***FREE DVD!**

*The Apollo 1040VR Turbine
and the award-winning
Apollo Atomizer® Spray Gun:
Precision Partners for the Perfect Finish*



DON'T SPRAY YOUR MONEY AWAY!

WITH 80-90% TRANSFER EFFICIENCY - APOLLO SAVES YOU 50-60% ON COATINGS



Order Yours Today 888-900-4857 (HVLV) www.hvlp.com

** For a Free Info DVD Call 888-900-4857 (HVLV) - View It at www.hvlp.com/live.php*

Dept. W610



*Carefully Crafted
Fine Quality*

Wood turnings and components from
Osborne Wood Products, Inc.
are the perfect complement for your
woodworking projects.



Carved Moldings

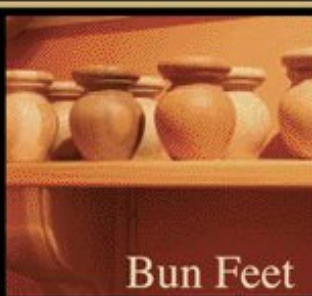

Bun Feet



Corbels



WWW.BUN-FEET.COM

866.963.5580

www.WorldMags.net & www.Journal-Plaza.net

Better Homes and Gardens®

WOOD PATTERNS®

July 2010

Issue 198

Dear Reader: As a service to you, we've included full-size patterns on this insert for irregular-shaped and intricate project parts. You can machine all other project parts using the Materials List and the drawings accompanying the project you're building.

© Copyright Meredith Corporation, 2010. All rights reserved. Printed in the U.S.A. Meredith Corp., the publisher of WOOD Patterns®, allows the purchaser of this pattern insert to photocopy these patterns solely for personal use. Any other reproduction of these patterns is strictly prohibited.

**Double Pushstick
Page 10**

**PUSHSTICK
FULL-SIZE PATTERN
(2 needed)**

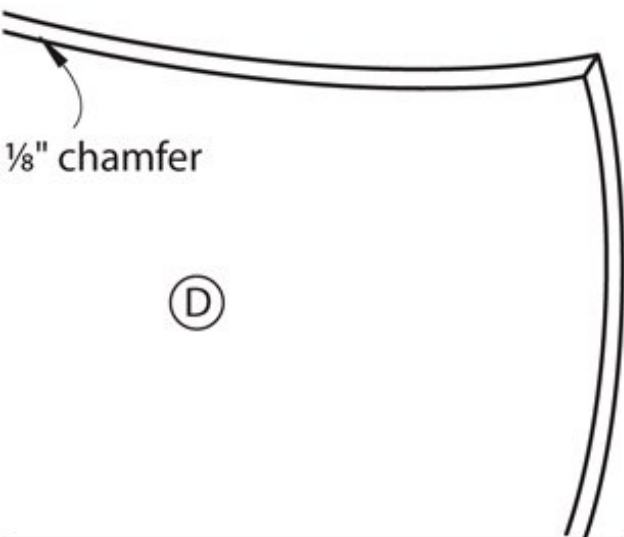
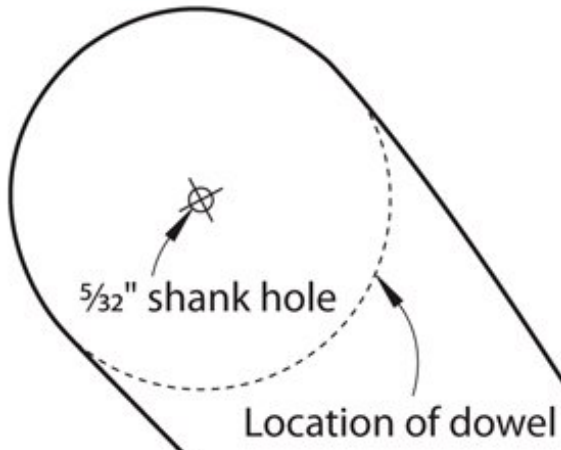

Dancing Clock Page 72

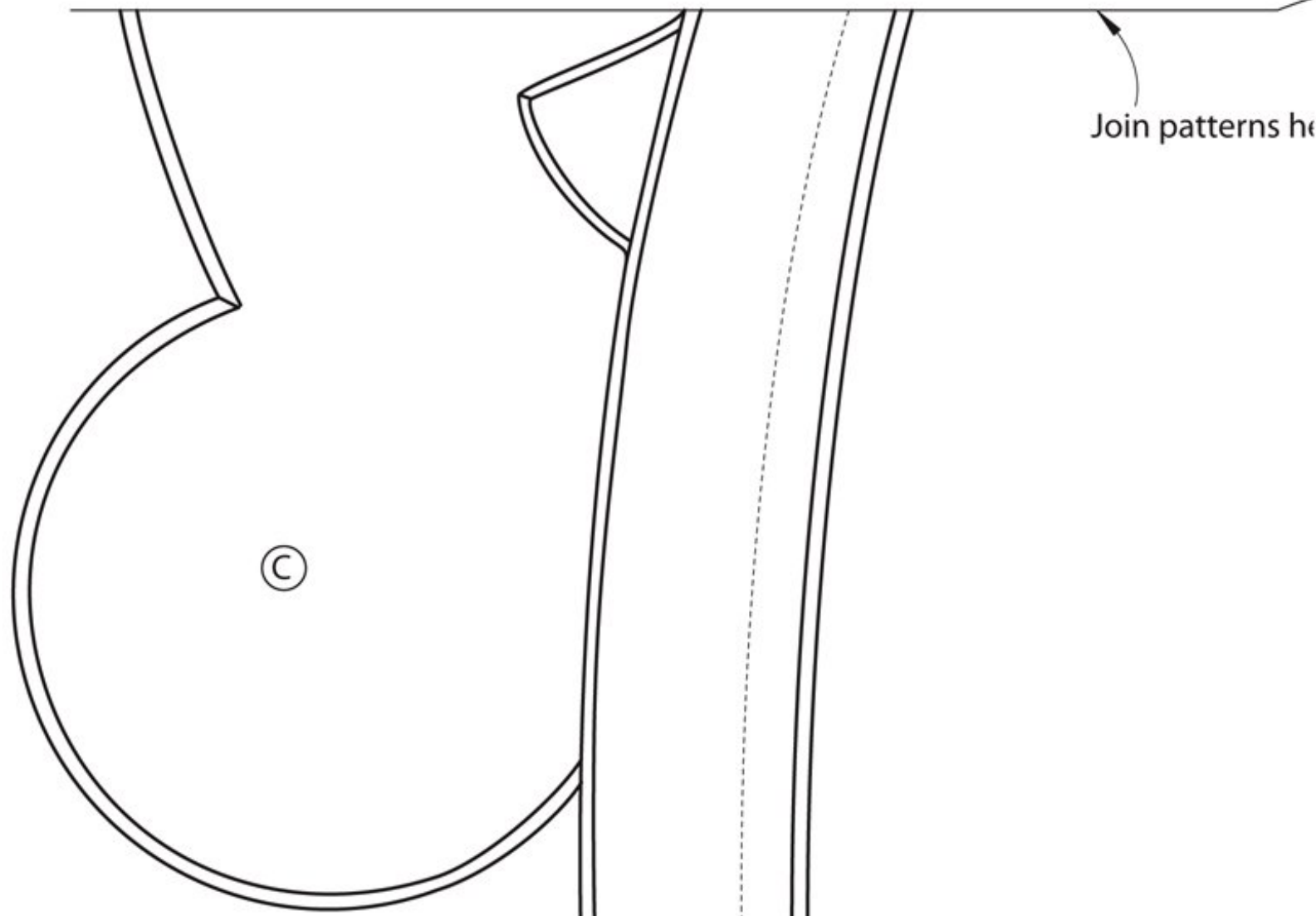

ere.

**CLOCK BOTTOM
FULL-SIZE PATTERN**
(4 needed)

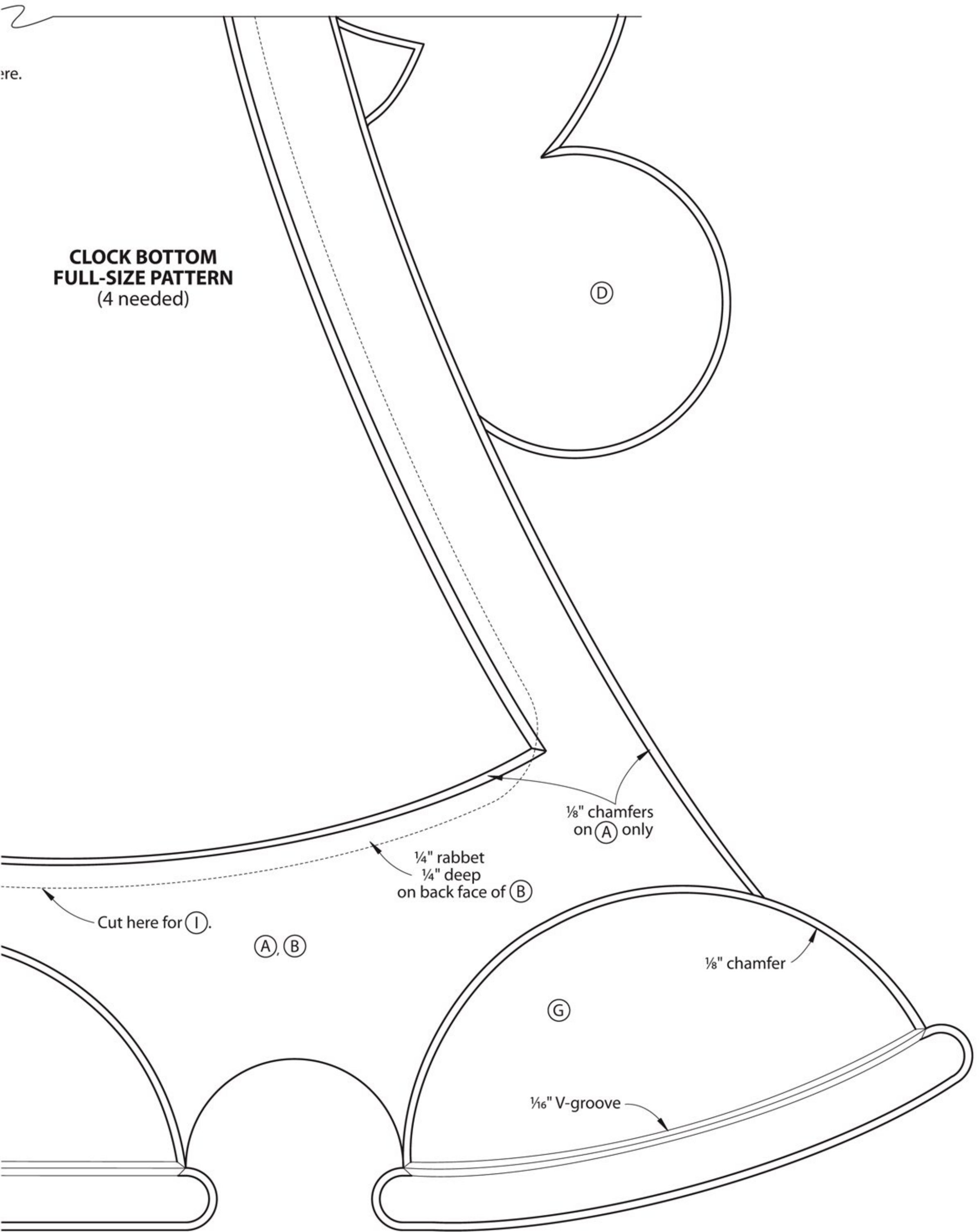

Dancing Clock Page 72

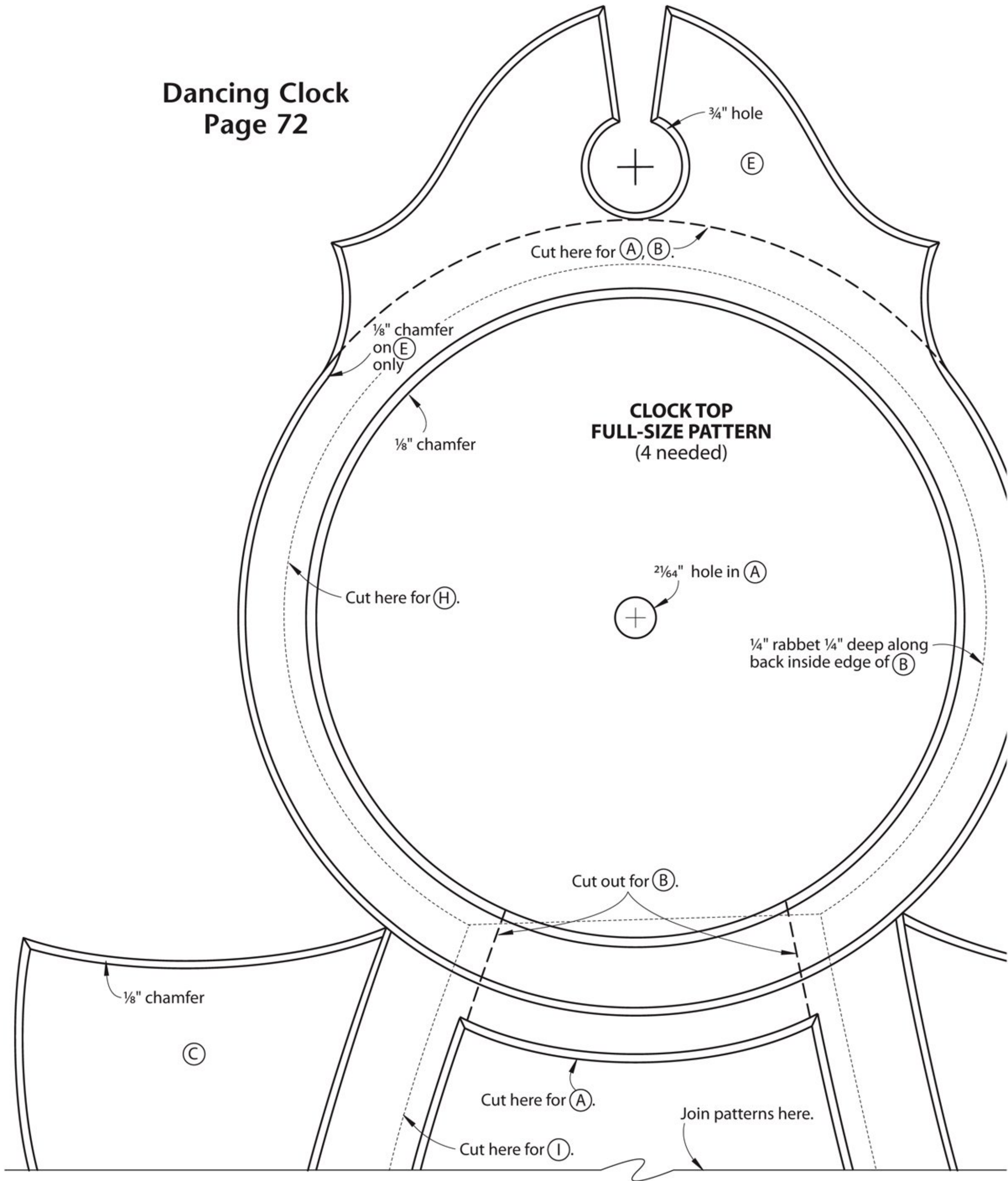

Cut Dead-On Miterers Every Time

Build this sled in one evening and enjoy making perfect mitered frames for years to come.

You'll turn to this miter sled like a trusted friend whenever you need gap-free corners. To make mitering a cinch, even on long pieces, T-tracks hold a stopblock anywhere along the 25"-long fences. A hardwood block behind the fences shrouds the blade while channeling sawdust downward into the saw.

Before you build this sled, consult the owner's manual to tune up your saw. (See **More Resources** on page 51 for more articles and a video on saw setup.)

Build your super sled

Begin by cutting the sled base to size from $\frac{3}{4}$ " Baltic birch plywood [**Exploded View, right**]. Cut two 18"-long hardwood runners to fit your tablesaw miter slots and two 1x3x25" hardwood miter fences. Using a dado blade that matches the width of your T-track (see **Sources**), center a groove in each miter fence deep enough to recess the T-tracks flush with the fence faces. Cut T-tracks about 1" shorter than the fences and screw them

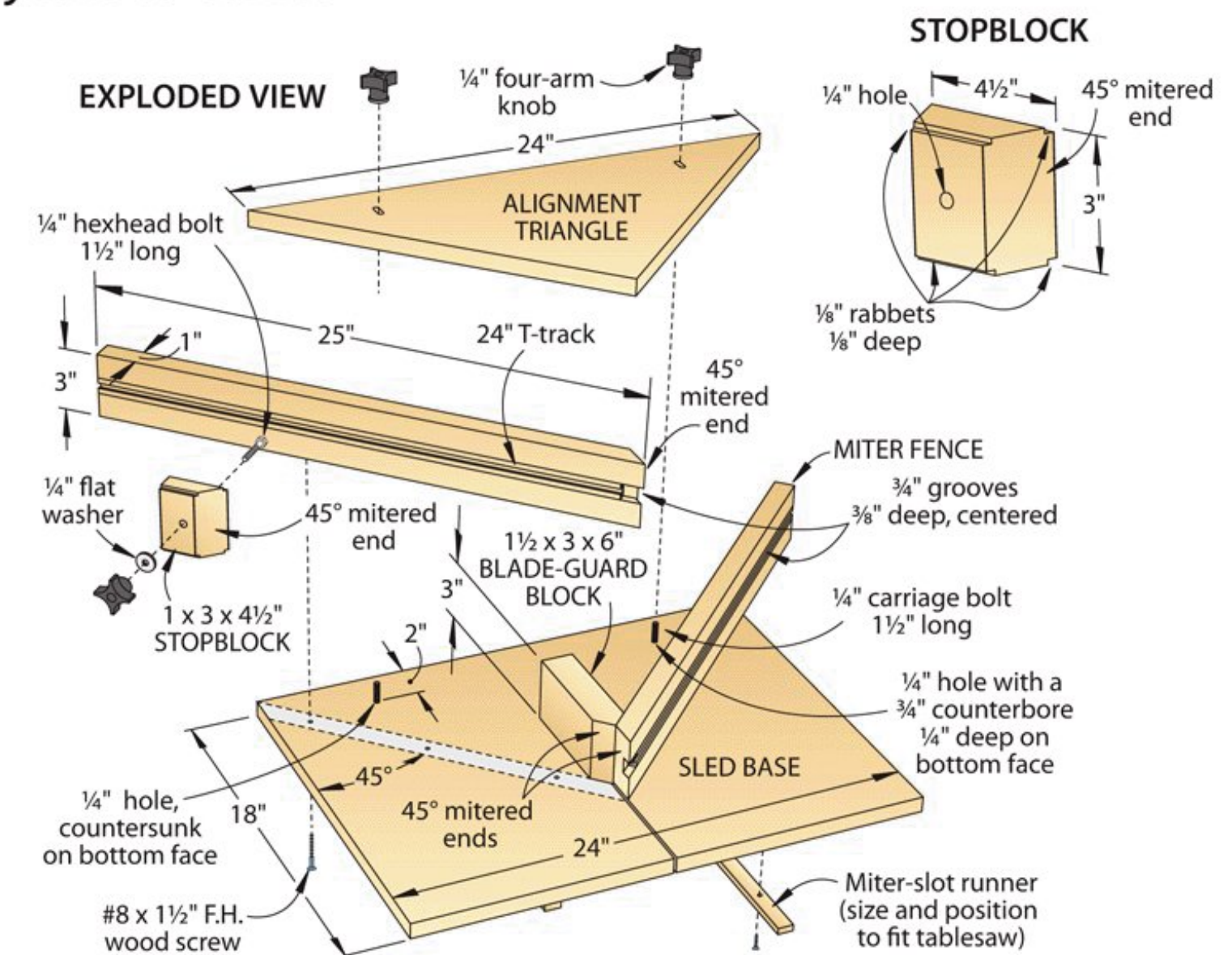

in place with one end flush with the outside end of each fence.

Install a saw blade, lower it completely, and adjust the rip fence to center the sled base above the blade.

Quick Tip: Make your "runner" buddies proud. Drop two dimes in each miter slot and lay the miter-slot runners on top of them so the runners stand just proud of the saw table.

ALIGNMENT TRIANGLE

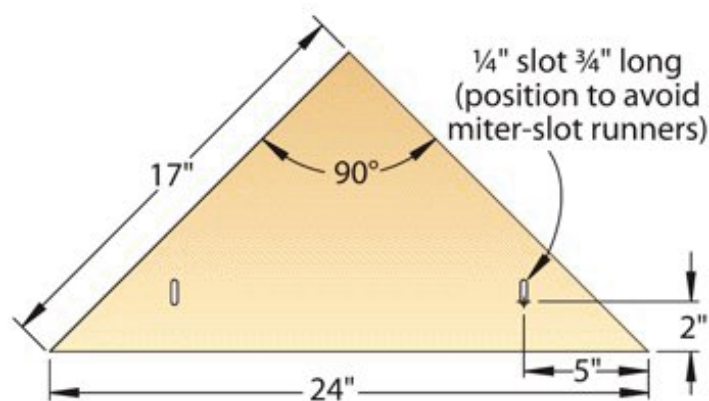

Next, attach the sled base to the runners [Photo A] by pressing it against the tape and slide the base off the saw. Flip the base over to countersink, drill, and screw the runners to the sled base.

Now drill two $\frac{1}{4}$ " holes 2" from the back edge of the sled base, without drilling the miter-slot runners. Counterbore holes on the underside of the base to accept a $\frac{1}{4} \times 1\frac{1}{2}$ " carriage bolt head.

From $\frac{3}{4}$ " MDF or an MDF-core sheet, cut a 17" square and use a reliable square to check for a precise 90° corner. Using a bandsaw or jigsaw, cut the square in half diagonally. Center and clamp one triangle onto the sled base while keeping the long edge flush with the back edge of the sled base. Turn the base and triangle upside down and transfer the $\frac{1}{4}$ " hole locations to the triangle. Remove the triangle and lay out two $\frac{3}{4}$ "-long slots perpendicular to the long edge and centered on the hole locations. Drill pairs of $\frac{1}{4}$ " holes to define the slot ends and cut away the waste between the holes.

Now loosely bolt the alignment triangle onto the sled base with its point centered. Using the 45° angle on a combination square, align the triangle on the sled base [Photo B].

Next, use the triangle and sled to miter one end of a test scrap until it fits the 45° angle on your square with no gaps. Then make test cuts in four pieces of scrap and check that they go together without gaps, as shown in "How to tell if you're winning the frame game" on page 51.

After your sled cuts airtight miters using the alignment triangle, you're ready to attach the two miter fences. Use the sled to miter the fence ends where the T-track stops short, and apply double-faced tape to the bottom edges [Photo C]. Press one fence against the edge of the alignment triangle with the mitered tip just over the kerf in the sled base. Then press it in place. Repeat for the other miter fence. Your first cut will trim the fence miters just enough to create a zero-clearance backer.



A Attach double-faced tape to the miter-slot runners and align them with the front edge of the saw table. Press one edge of the sled base against the rip fence as you tilt the sled down against the table and press it against the miter-slot runners.

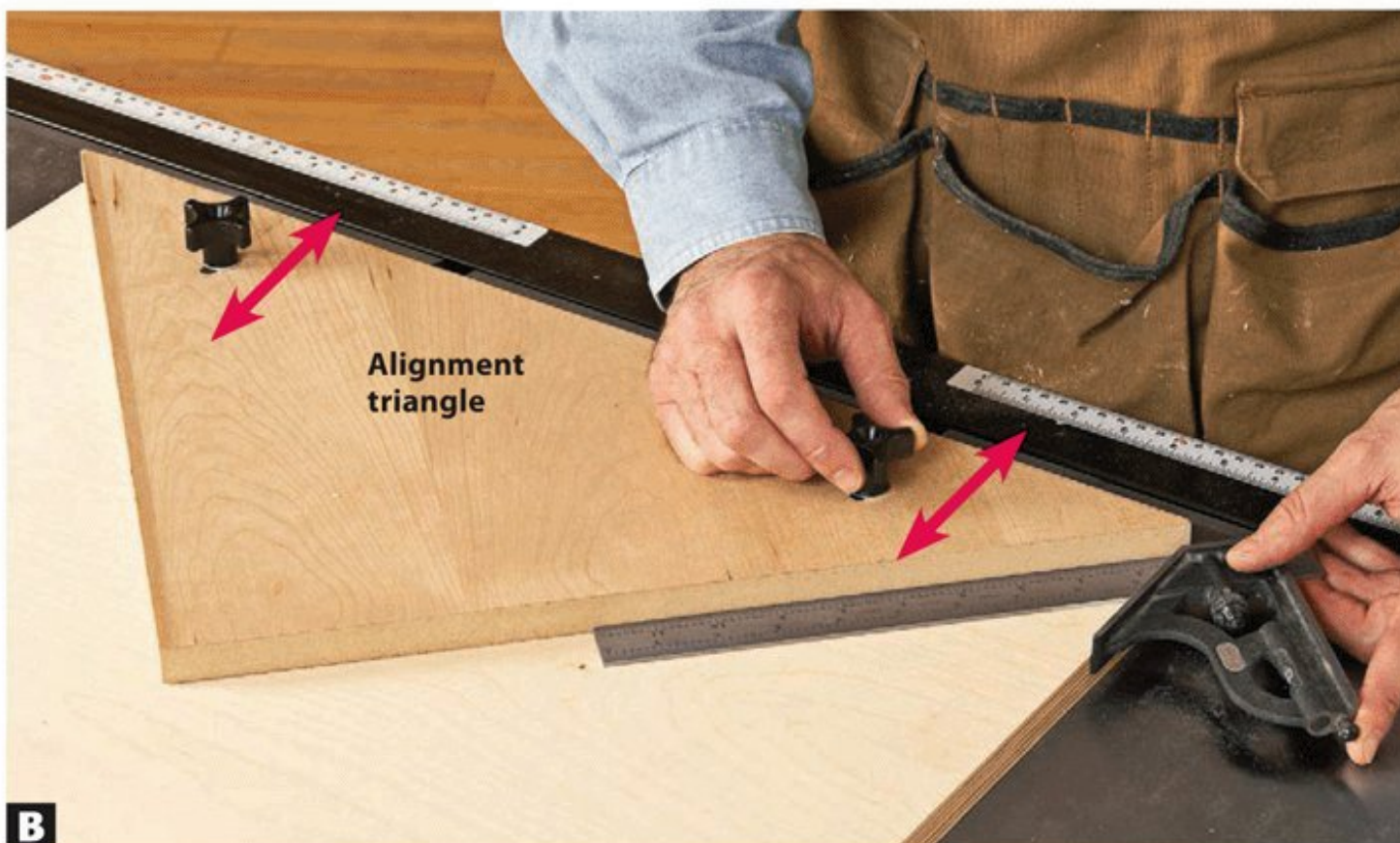

B Press your combination square against the edge of the sled base and move the alignment triangle up or down until the edge rests tight against the square. Do the same on the other side. Then secure the alignment triangle in place by tightening the knobs.

To test the accuracy of the miter fences, again miter the four test scraps and assemble them into a frame. Once you achieve gap-free miters, drill and screw the miter fences to the sled base.

To make the blade guard, laminate

two pieces of $\frac{3}{4} \times 3 \times 6$ " hardwood and allow to dry. Use your tablesaw with the blade tilted 45° to bevel both faces at one end, forming a point at the center. Then glue and clamp this blade-guard block to the sled base behind the fences

A sled helps you cut tighter miters

A dedicated tablesaw miter sled gives you two big advantages over miter gauges and mitersaws. First is price. You can build this sled from a quarter-sheet of Baltic birch plywood, scrap hardwood and MDF, and \$25 in

hardware—far less than a mitersaw or an aftermarket miter gauge. Second, after the initial alignment, you'll get consistent results with a miter sled without spending additional time on setups and test cuts.

How to tell if you're winning the frame game



To test the position of the alignment triangle, cut a test frame with four equal sides of $\frac{3}{4} \times 3 \times 12$ " MDF. Those eight miter cuts multiply the slightest misalignments enough to find and fix them.

Here's how to go about it: Although you'll normally cut from both sides of your miter sled when it's finished, make these test cuts *only from the left side*. First miter one end of each piece. Use

double-faced tape to adhere a stopblock to the sled base against the alignment triangle and a hair less than 9" from the center kerf. Flip each test piece end for end and cut the second miters.

Tape three mitered corners tightly together and examine the fourth joint. If it looks like the one *far left*, rotate the alignment triangle counterclockwise. If the fourth joint resembles the corner *middle left*, gently rotate the alignment triangle clockwise.

If you end up with an even gap on all four corners, like the one *near left*, blame the saw-blade tilt. Check the blade with a reliable square or drafting triangle to make sure it stands 90° to the saw table.

[Exploded View]. Finally, cut a stopblock to size as shown *opposite* and drill it for a $\frac{1}{4}$ " hexhead bolt.

Let's go sledding

To make a frame, first cut blanks for both pairs of frame sides. Using the right fence of your jig, miter one end of each frame part, as shown on *page 49*.

For four sides of equal length, set your stopblock on the left miter fence and cut the opposite end of all four parts. For sides of unequal length, cut the longest sides first so you'll still have a usable blank for the short sides in case you make a mistake. Then reset your stopblock and cut the short sides.

To miter extra-long parts, first glue a beveled block to a strip of plywood or MDF cut to the length you need to accommodate your frame parts. Then clamp the extension to a sled fence [Photo D] and miter the opposite ends of your frame parts. 🌲



Double-faced tape holds the miter fences in position while you check their alignment by cutting test pieces to make a frame. The tip of the fence overlaps slightly less than half of the saw kerf in the sled base, with the T-track recessed 1" from the end.



For workpieces longer than your miter fences, cut them to identical lengths using a stopblock extension. Make the stopblock 2" thick so that the mitered end of your workpiece can touch the mitered end of the stopblock.

MORE RESOURCES

FREE VIDEO

- "Tune Up Your Tablesaw" at woodmagazine.com/tstuneup

RELATED ARTICLES

- "Tune Up Your Tablesaw" issue 152 (November 2003) \$
- "Miter Gauges & Sleds" issue 179 (October 2007) \$

(\$=Download this article from woodmagazine.com/plans for a small fee. Type "tune up" or "miter gauge" in the Search box.

Sources

T-track: 4' aluminum track no. 20054, \$20, Rockler, 800-279-4441, rockler.com.

Knobs: Four-arm knob with a $\frac{1}{4}$ " 18-thread insert (2) no. 27R14, \$2.50, Woodcraft, 800-225-1153, woodcraft.com.

Hall tree storage bench

An attractive and convenient place for a busy family's outdoor gear

AT A GLANCE

- Overall dimensions: 35¾" wide × 25½" deep × 78½" high.
- The lower cabinet provides a handy seat to tie or take off shoes.
- Store baskets of seasonal gloves, hats, and scarves in the bottom cubbies.
- Add a coat hook for each family member.

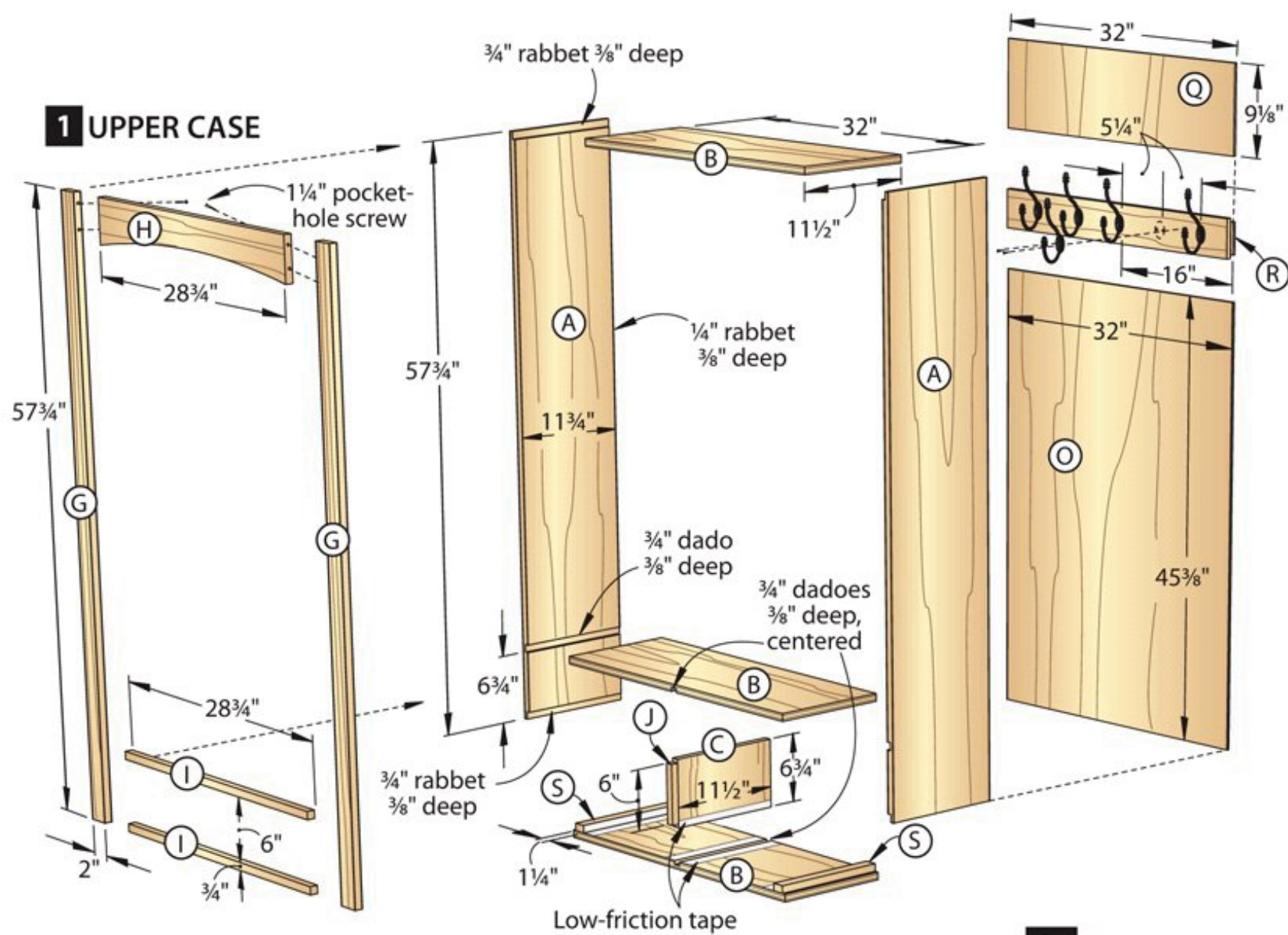

1b BACK RAIL DETAIL

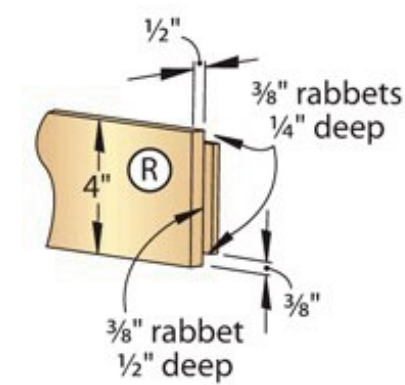

1a TOP RAIL LAYOUT

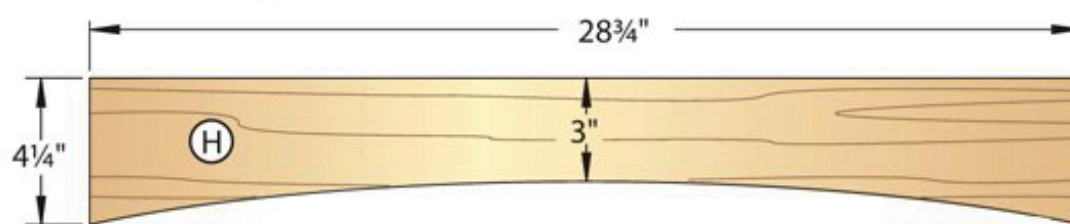

Keep this combination coatrack and bench near your entry door, then say goodbye to soggy shoes on the carpet and jackets tossed over the backs of chairs.

Race through the case

1 Cut the upper case sides (A); top, shelf, and bottom (B); divider (C); lower case sides (D); top and bottom (E); and divider (F) to size from 3/4" oak plywood [Drawing 1 and 2, Materials List, page 57].

2 Install a dado set to match the plywood thickness and an auxiliary fence to your tablesaw rip fence. Rabet the ends of the upper case sides (A) and lower case sides (D) where shown [Drawings 1 and 2]. Adjust the fence to cut centered dados on the upper case bottom and shelf (B) to accept the divider (C). Then cut centered dados on the lower case top and bottom (E) to accept the lower divider (F). Move your rip fence again to dado the upper sides 6 3/4" from the bottom end and the lower sides 1 1/2" from the bottom end. Finally, rabet the inside back edges of the upper sides and lower sides [Shop Tip, right].

3 Finish-sand the inside faces of the upper case sides (A), bottom (B), and lower case sides (D) to 220 grit. Sand the top face of the upper case shelf (B) and lower bottom (E); both sides of the upper case divider (C) and lower case divider

2 LOWER CASE

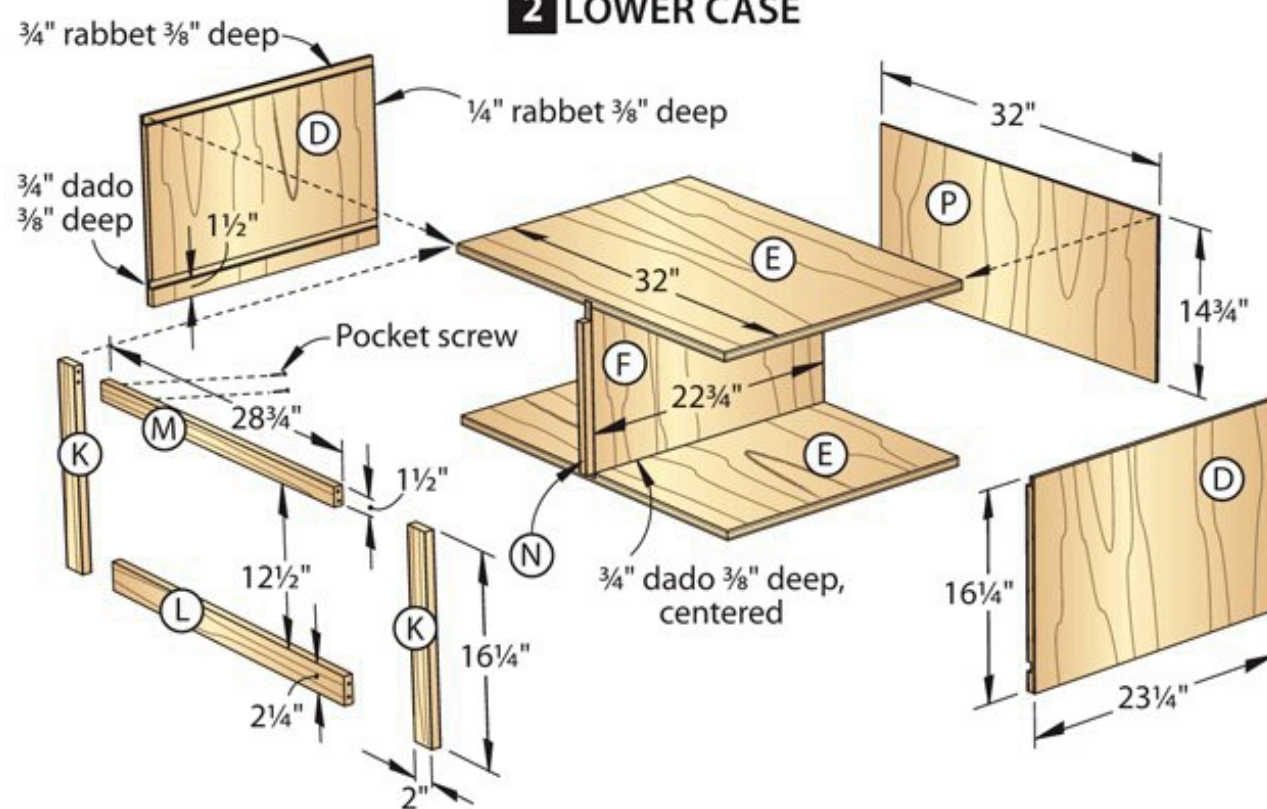

SHOP TIP

Read twice, rabet once

More than one woodworker has confused drawing dimensions calling for a "1/4" rabet 3/8" deep" when setting up a tablesaw or router. To keep dimensions straight, picture the finished joint. The dimension to rabet refers to the width of the rabet necessary to accept a mating piece, in this case the 1/4"-thick backs (O, P, Q). The rabet depth is typically measured from a face, not an edge.



BEGIN WITH ONE SIDE AT A TIME



A Rest one upper case side (A) on riser blocks for clamp clearance and glue the upper shelf, bottom (B), and divider (C).

(F); and the lower face of the lower case top (E).

4 Glue and insert the upper case shelf (B) into the dado in a side (A) with their front edges flush [Drawing 1]. Glue and insert the upper case divider (C) and bottom (B) and clamp square [Photo A]. After the glue dries, lay the assembly flat and glue the other side to the shelf and bottom [Photo B].

5 Repeat step 4 with the lower case sides (D), top and bottom (E), and divider (F) to assemble the lower case [Drawing 2]. Finish-sand the outsides of both cases to 220 grit.

Now trim the cases

1 Cut the upper case stiles (G) to size and top rail (H) 1" longer than listed [Drawing 1]. Temporarily clamp the stiles to the sides (A) [Photo C]. Then mark and crosscut the top rail to length.

2 Use a fairing stick to lay out the arc on the top rail (H) [Drawing 1a]. (See **More Resources**, page 57, for plans to make a fairing stick.) Then cut on the waste side and sand to the arc line.

3 Drill and drive pocket-hole screws to join the top rail (H) to the upper case stiles (G). (For tips on how to make pocket-hole joints, see "Five-Minute Face Frames" on page 42.) Glue and clamp the

ATTACH THE SECOND SIDE

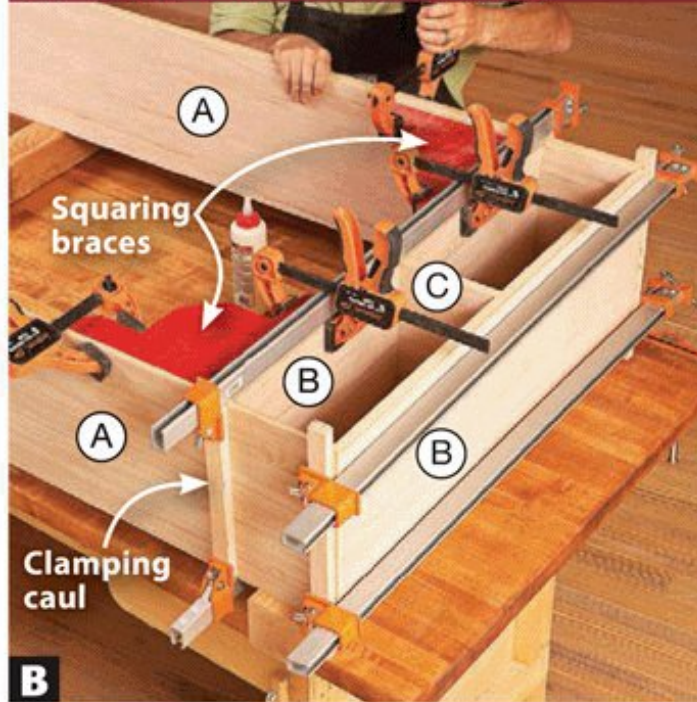

B Scraps cut $\frac{1}{8}$ " thinner on the ends than the middle (cauls) apply clamping pressure to the center of the upper sides (A).

rail-and-stile assembly (G/H) to the upper case (A/B/C). See the **Shop Tip below** for help managing the long stiles during the glue-up.

4 Cut the drawer rails (I) and drawer divider trim (J) 1" longer than listed. Measure between the upper case stiles (G). Trim drawer rails to that length and glue and clamp them in place. Cut the divider trim to fit between the drawer rails; then glue and clamp it in place.

5 Repeat steps 3 and 4 to cut and attach the lower case stiles (K), rails (L, M), and center stile (N).

Add the crowning touches

1 Edge-glue material to make a blank for the seat (T). Cut the blank to size and create a bullnose by routing $\frac{3}{8}$ " round-overs on the ends and then the front edges [Drawing 3].

2 Rip two $\frac{3}{4} \times 2 \times 48$ " blanks to make the cove moldings (U, V, W). Rout $\frac{1}{2}$ " coves on two edges of each blank; then rip cove strips from the blanks [Photos D and E].

3 From scrap, cut two 1"-wide spacers about 12" long. Double-faced tape them to the top rail (H) with the long

MARK A NO-FAIL RAIL

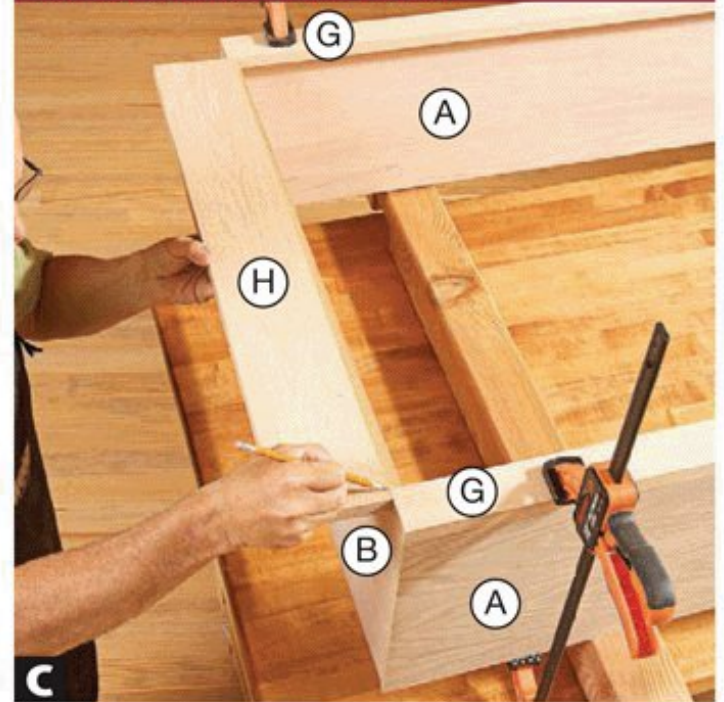

C With the outside edges of the upper stiles (G) clamped flush with the case (A/B), mark the exact length of the top rail (H).

edges flush with the top of the upper case. Miter one end of a cove strip, temporarily clamp it against the spacer, and mark the upper front cove (U) length [Photo F]. Then miter-cut it to length. Repeat (without a spacer) to cut the lower front cove [Drawing 4].

4 Clamp the upper front cove (U) in place. Miter opposite ends of each remaining cove molding strip and butt the miters against the front cove. Mark and cut the top side coves (V) to length. Then glue and clamp them in place against the spacers. Repeat (without spacers) for the lower side coves (W).

5 Follow steps 3 and 4 (without the spacers) to cut the front crown (X) and side crown (Y) moldings to size from $\frac{3}{4}$ "-wide, store-bought crown molding. (Or make your own molding, as shown on page 18.) Then glue and clamp the front and side crowns to the top rail (H) and upper sides (A) [Photo G].

6 Cut blanks for the base front (Z) and base sides (AA) about 3" longer than listed. Rout $\frac{1}{2}$ " coves on one edge of each blank. Then cut six 5"-long spacers from a $\frac{1}{2} \times 2\frac{1}{8}$ " scrap blank. Attach to them the back faces of the base front blank and

SHOP TIP

Avoid glue smears

To keep glue smears off the inside faces of the face frame (G/H), rest it on scrap blocks as you apply glue to the upper case (A/B/C) edges. First remove scrap blocks to position and clamp the top rail (H). Working from the top down, clamp the upper stiles (G) to the case on both sides, aligning the stile edges with the case as you go. As you add clamps, remove scrap blocks until you reach the bottom of the case.

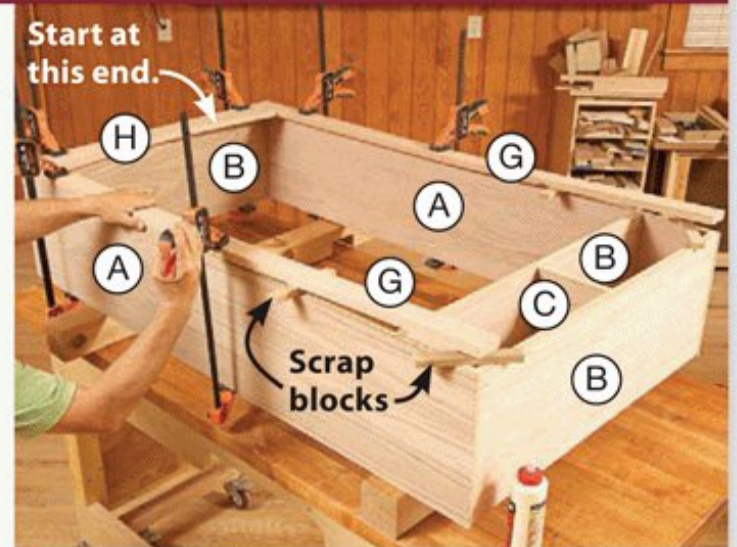

MAKE YOUR OWN CUSTOM COVE MOLDINGS IN TWO QUICK STEPS

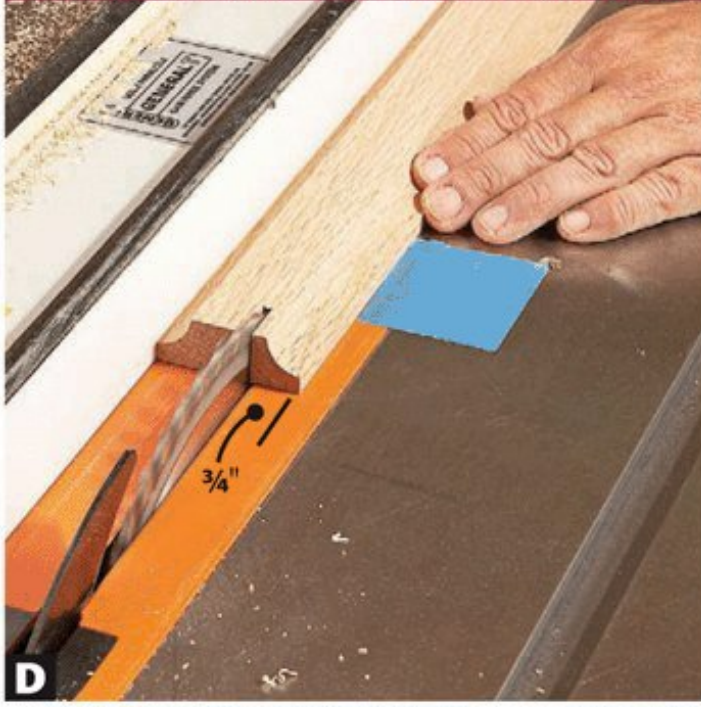

To make uniform moldings, place a piece of tape $\frac{3}{4}$ " from the edge of the blade. Adjust the fence so the blank rests against the tape and rip the first molding (left). Move the fence to again place the blank edge against the tape and rip the second molding (right).

CUT DEAD-ON MOLDING MITERS

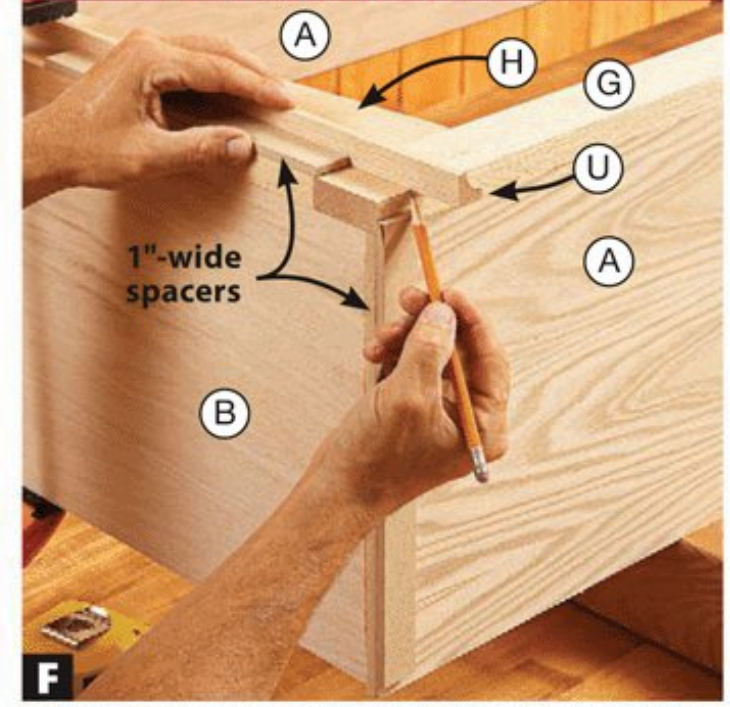

Clamp the top front cove molding (U) to the upper case. Marking and mitering it to length eliminates gaps at the corners.

3 SEAT EDGE DETAIL

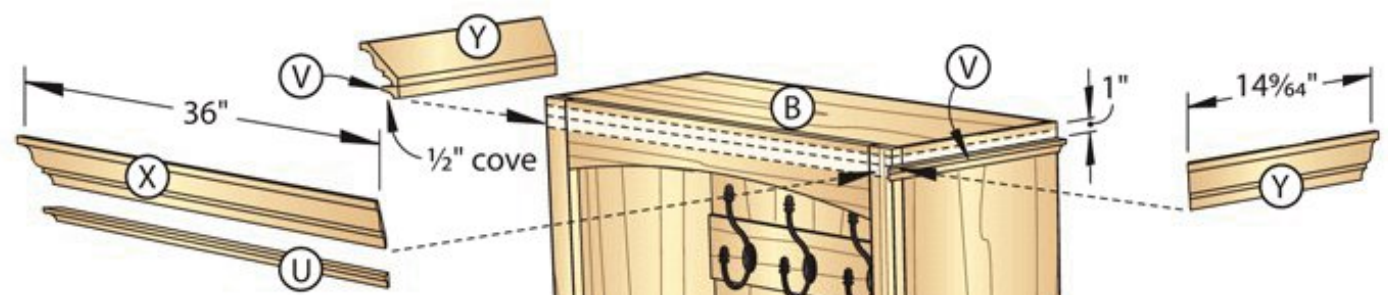
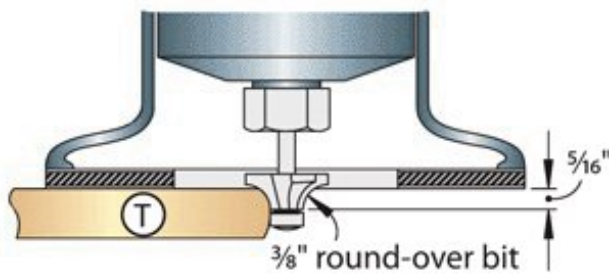

4 EXPLODED VIEW

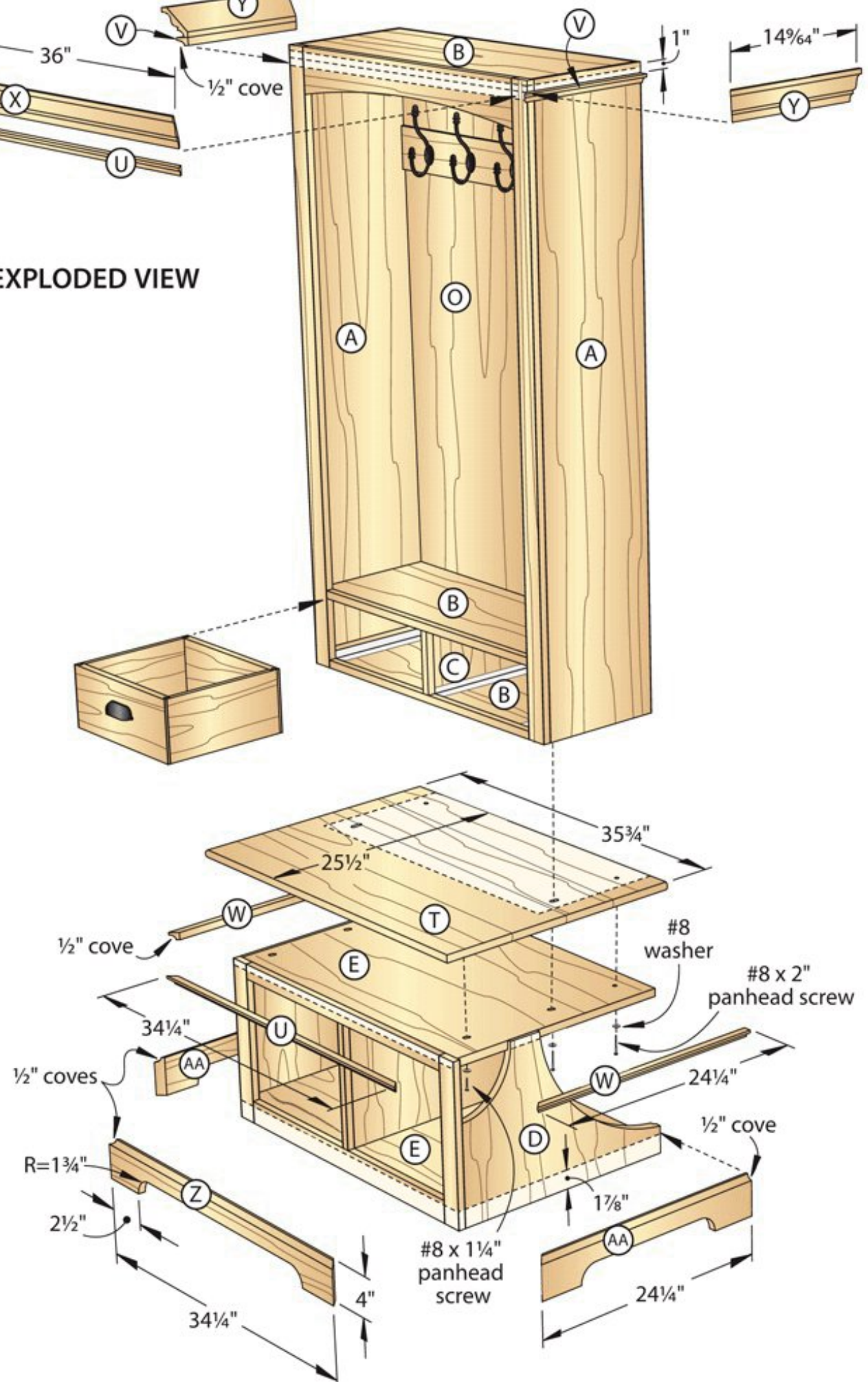

base side blanks with double-faced tape. Miter one base side and clamp it to the lower end of the bottom case. Then mark and cut the base side to length. Miter one end of the base front blank to mate it with the mitered base side and clamp it to the lower base rail (L) [Photo H]. Mark and miter-cut the base front to length. Then miter and cut the other base side to length.

7 Lay out cutouts on the base front (Z) and base sides (AA). Bandsaw on the waste sides and sand to the layout lines. Then glue and clamp the base front and sides to the lower case using $2\frac{1}{8}$ "-wide spacers to help position the parts.

5 SCREW SLOT DETAIL

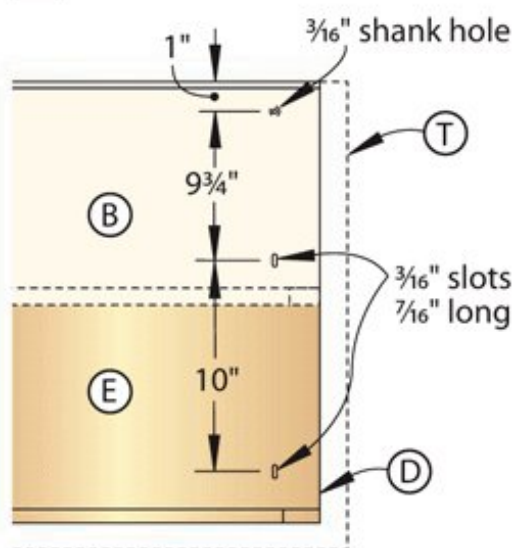

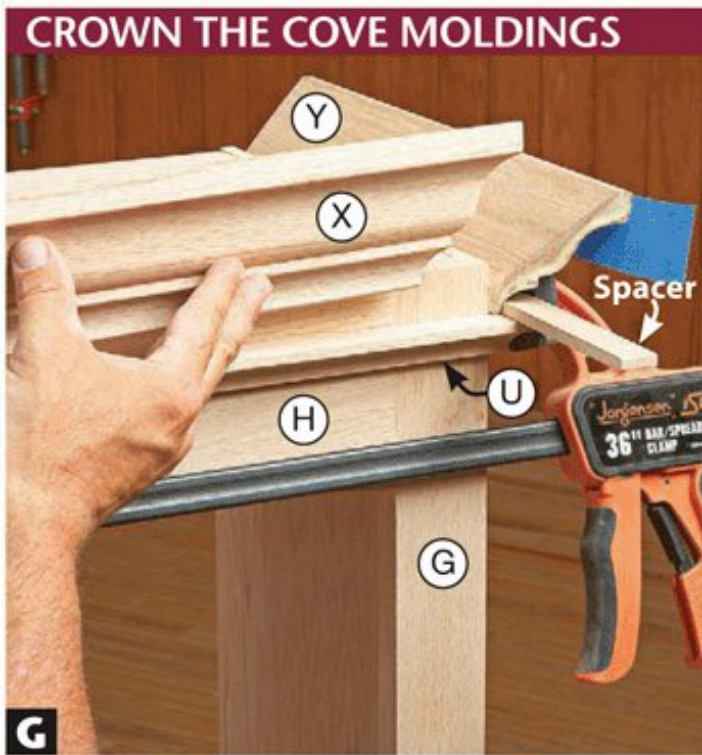

G Reuse your 1"-wide spacers as cauls for clamping crown molding to the cabinet. Tape holds the miter together.

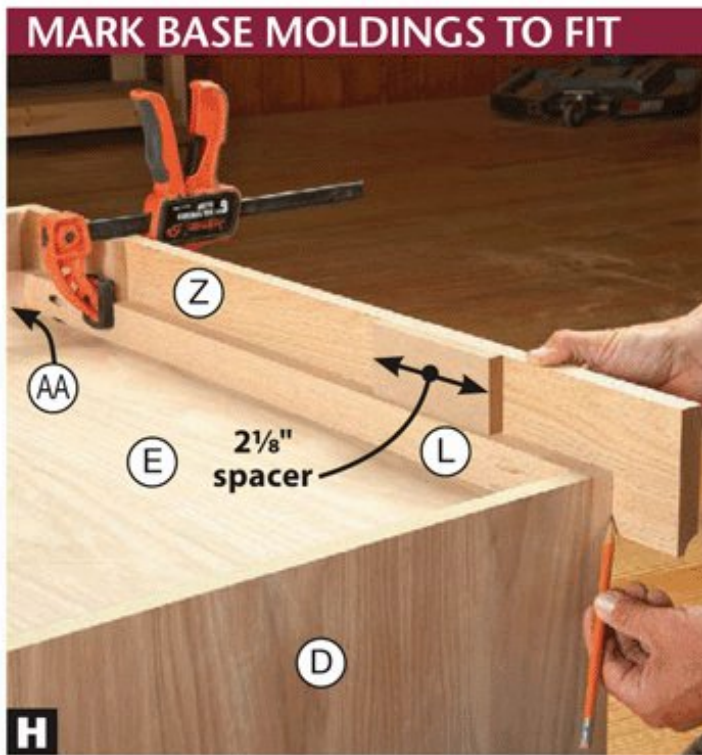

H Work your way around the case, cutting a base side (AA) to length before marking and miter-cutting the base front (Z) to length.

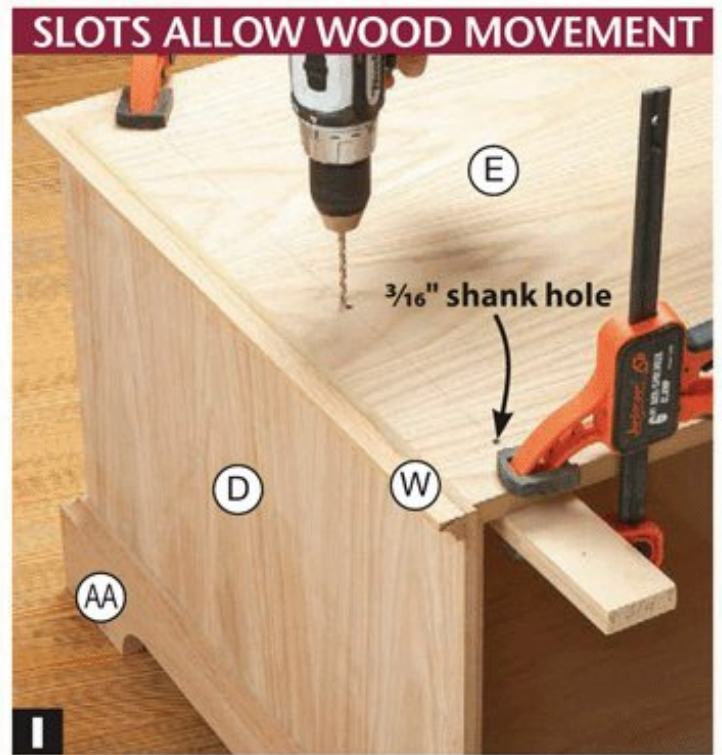

I To make seat (T) slots, drill $\frac{3}{16}$ " holes $\frac{5}{16}$ " apart and use a coping saw or chisel to cut out the waste in between.

Bring the cases to a close

1 Measure between rabbets on the back edge of the upper case sides (A) and the lower case sides (D). Rip a sheet of $\frac{1}{4}$ " plywood to that width. Then cut the middle back (O) and lower back (P) to length. Set aside the rest of the strip for the upper back (Q).

2 Cut the back rail (R) length equal to the middle back (O) width. Cut rabbets to accept the middle back and upper back (Q) [Drawing 1b]. Rabbet the ends on the front face to fit rabbets on the upper case sides (A).

3 Retrieve the middle back (O) and screw it to the upper case sides (A), shelf, and bottom (B). Glue and clamp the back rail (R) to the sides and against the middle back. Measure for the length of the upper back (Q) and cut to size. Screw the upper back to the sides (A) and top (B) and screw the lower back to the lower case. You'll finish the upper, middle, and lower backs separately from the cases, so remove them for now.

4 Cut drawer spacers (S) so that one edge rests flush with the upper case stile (G) edge. Glue and clamp spacers to the upper sides (A) and bottom (B).

5 Clamp a scrap backer to the underside of the lower case top (E) to avoid tear-out. Drill mounting holes and slots to attach the seat (T) and upper case [Drawings 4 and 5, Photo I].

6 Clamp the seat (T) to the lower case, centered left to right and with the back edges flush. Then transfer the locations of the shank and slot holes in the lower top (E) to the seat. Drill and cut the holes and slots in the seat. Then

clamp the seat to the lower top (E) centered from side to side with the back edges flush, and screw through the lower case and seat into the upper case.

Drawers and more

1 Double-check the drawer-opening dimensions. Then cut the drawer fronts and backs (BB), sides (CC), and bottoms (DD) to size. Mount a $\frac{1}{4}$ " dado blade in your tablesaw and follow the

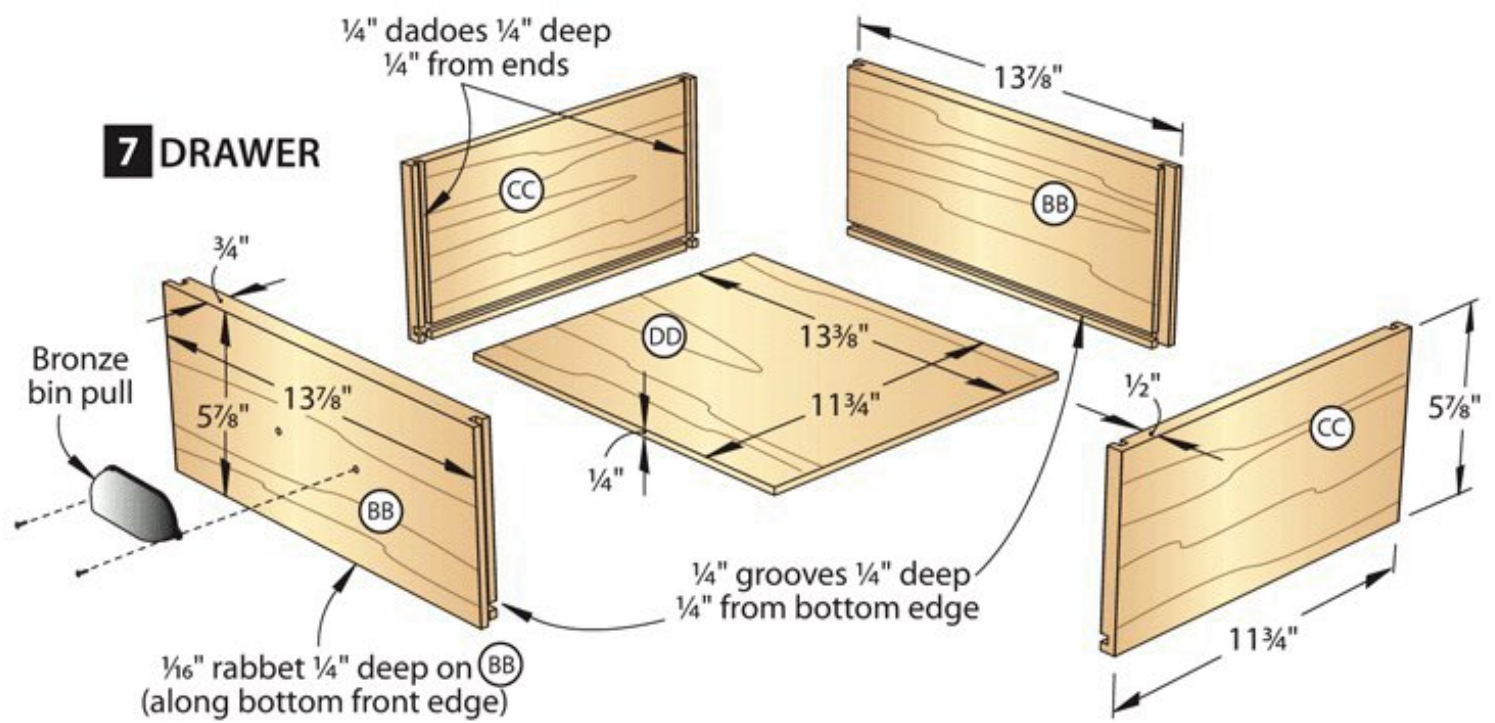

6 MACHINING THE DRAWER PARTS

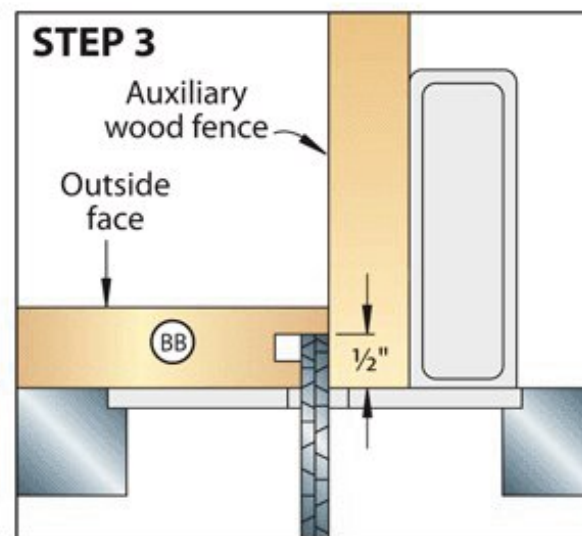
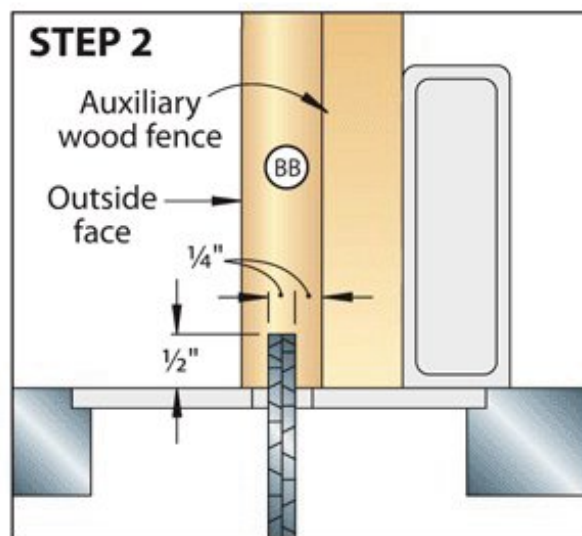
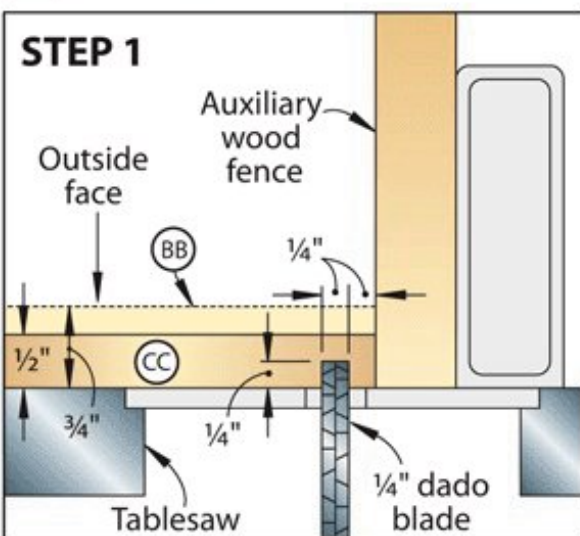

6a DRAWER JOINT DETAIL

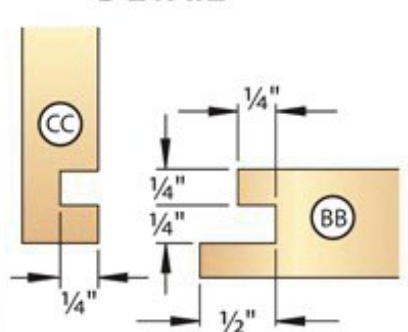

three steps in **Drawing 6** to create joints for the drawer fronts and backs (BB) and sides (CC) [**Drawing 6a**].

2 Sand the inside faces of the drawer front/back (BB), drawer sides (CC), and drawer bottoms (DD) to 220 grit. Then glue and clamp the assembled drawers [**Drawing 7**].

3 After the glue dries, cut a 1/16" rabbet on the lower edge of the drawer front to create a shadow line equal to the reveal around the other three edges.

4 Drill and screw the coat hooks to the back rail (R) [**Drawing 1**] and the pulls to the drawers.

5 Finish-sand the assembly and drawers to 220 grit where needed. Then remove the hardware and separate the cases. Apply stain (we used Varathane Summer Oak no. 211756) and three coats of satin polyurethane, sanding with 320-grit sandpaper between coats.

6 After the finish dries, reassemble the cases and attach low-friction tape to the upper case bottom (B) and drawer spacers (S) [**Drawing 1**]. Then gather up those jackets and gloves scattered around the house and organize them in their new home. 🌳

Written by **Bob Wilson** with **Jeff Mertz**
Project design: **Kevin Boyle**
Illustrations: **Roxanne LeMoine; Lorna Johnson**

Cutting Diagram

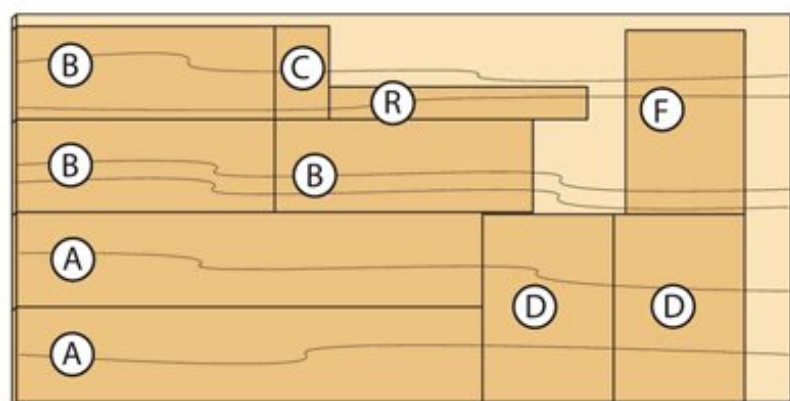

3/4 x 48 x 96" Red oak plywood

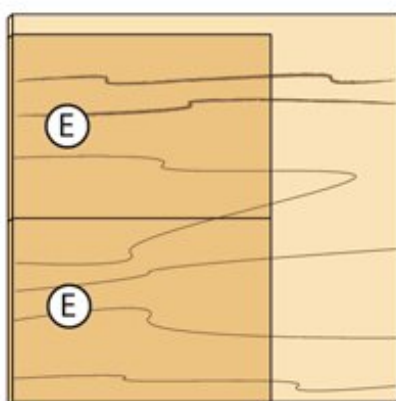

3/4 x 48 x 48" Red oak plywood

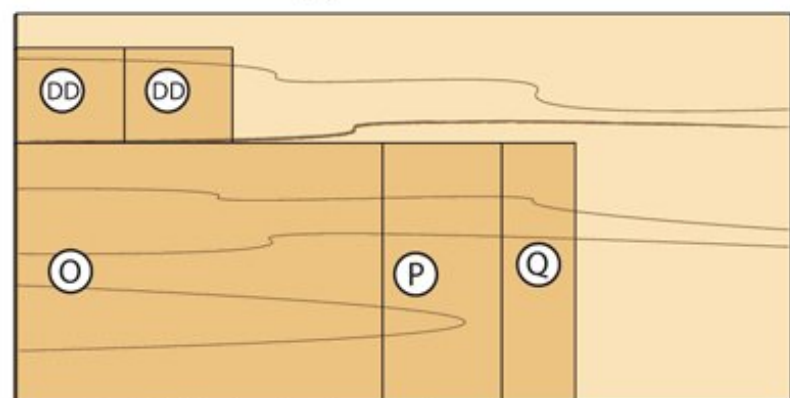

1/4 x 48 x 96" Red oak plywood



3 1/4 x 70" Red oak crown molding



3/4 x 5 1/2 x 96" Red oak (4 bd. ft.)



3/4 x 5 1/2 x 96" Red oak (4 bd. ft.)



3/4 x 7 1/4 x 96" Red oak (5.3 bd. ft.) (2 needed)



3/4 x 7 1/4 x 96" Red oak (5.3 bd. ft.)



3/4 x 5 1/2 x 96" Red oak (4 bd. ft.)

MORE RESOURCES

FREE VIDEOS

- "Perfect-Fitting Dadoes" woodmagazine.com/deadondado
- "Cutting Crown Molding" woodmagazine.com/crownmldg
- "Matching a Stain Color on Solid Wood and Plywood" woodmagazine.com/colormatch

FREE PLANS

- Squaring braces: woodmagazine.com/brace
- Fairing stick: woodmagazine.com/fairing



Materials List

Part	FINISHED SIZE			Matl.	Qty.	
	T	W	L			
upper case						
A	upper sides	3/4"	11 3/4"	57 3/4"	OP	2
B	upper top/shelf/bottom	3/4"	11 1/2"	32"	OP	3
C	upper divider	3/4"	11 1/2"	6 3/4"	OP	1
D	lower sides	3/4"	23 1/4"	16 1/4"	OP	2
E	lower top/bottom	3/4"	22 3/4"	32"	OP	2
F	lower divider	3/4"	22 3/4"	14 3/4"	OP	1
G	upper stiles	3/4"	2"	57 3/4"	O	2
H*	top rail	3/4"	4 1/4"	28 3/4"	O	1
I*	drawer rails	3/4"	3/4"	28 3/4"	O	2
J*	drawer divider trim	3/4"	3/4"	6"	O	1
lower case						
K	lower stiles	3/4"	2"	16 1/4"	O	2
L*	lower base rail	3/4"	2 1/4"	28 3/4"	O	1
M*	upper base rail	3/4"	1 1/2"	28 3/4"	O	1
N*	base center stile	3/4"	3/4"	12 1/4"	O	1
O	middle back	1/4"	32"	45 3/8"	OP	1
P	lower back	1/4"	32"	14 3/4"	OP	1
Q	upper back	1/4"	32"	9 1/8"	OP	1
R	back rail	3/4"	4"	32"	OP	1
S	drawer spacers	3/4"	1 1/4"	11 1/2"	O	2
top and trim						
T*	seat	3/4"	25 1/2"	35 3/4"	EO	1
U*	front coves	3/4"	3/4"	34 1/4"	O	2
V*	top side coves	3/4"	3/4"	13 1/4"	O	2
W*	lower side coves	3/4"	3/4"	24 1/4"	O	2
X*	front crown	1/2"	3 1/4"	36"	OC	1
Y*	side crowns	1/2"	3 1/4"	14 3/4"	OC	2
Z*	base front	3/4"	4"	34 1/4"	O	1
AA*	base sides	3/4"	4"	24 1/4"	O	2
drawers						
BB	fronts/back	3/4"	5 7/8"	13 7/8"	O	4
CC	sides	1/2"	5 7/8"	11 3/4"	O	4
DD	bottoms	1/4"	11 3/4"	13 3/8"	OP	2

*Parts initially cut oversize. See the instructions.

Materials key: O—red oak, OP—red oak plywood, OC—red oak crown molding, EO—edge-glued red oak.

Supplies: 1/4" pocket-hole screws, 1/4" panhead screws (2), #8x2" panhead screws (4), #8 washers (6), bronze bin pulls (2), bronze coat hooks (5), available from home centers.

Blade and bits: Dado set, 1/2" cove router bit, 3/8" round-over bit.

Source

Low-friction tape: 1"-wide slippery tape no. 25U04.01, \$11.50 for an 18' roll, Lee Valley Tools, 800-871-8158 or leevalley.com.

Dust Collection that Evolves with Your Shop

As your workshop grows, so do your dust-collection needs. Make today's system handle tomorrow's tools.

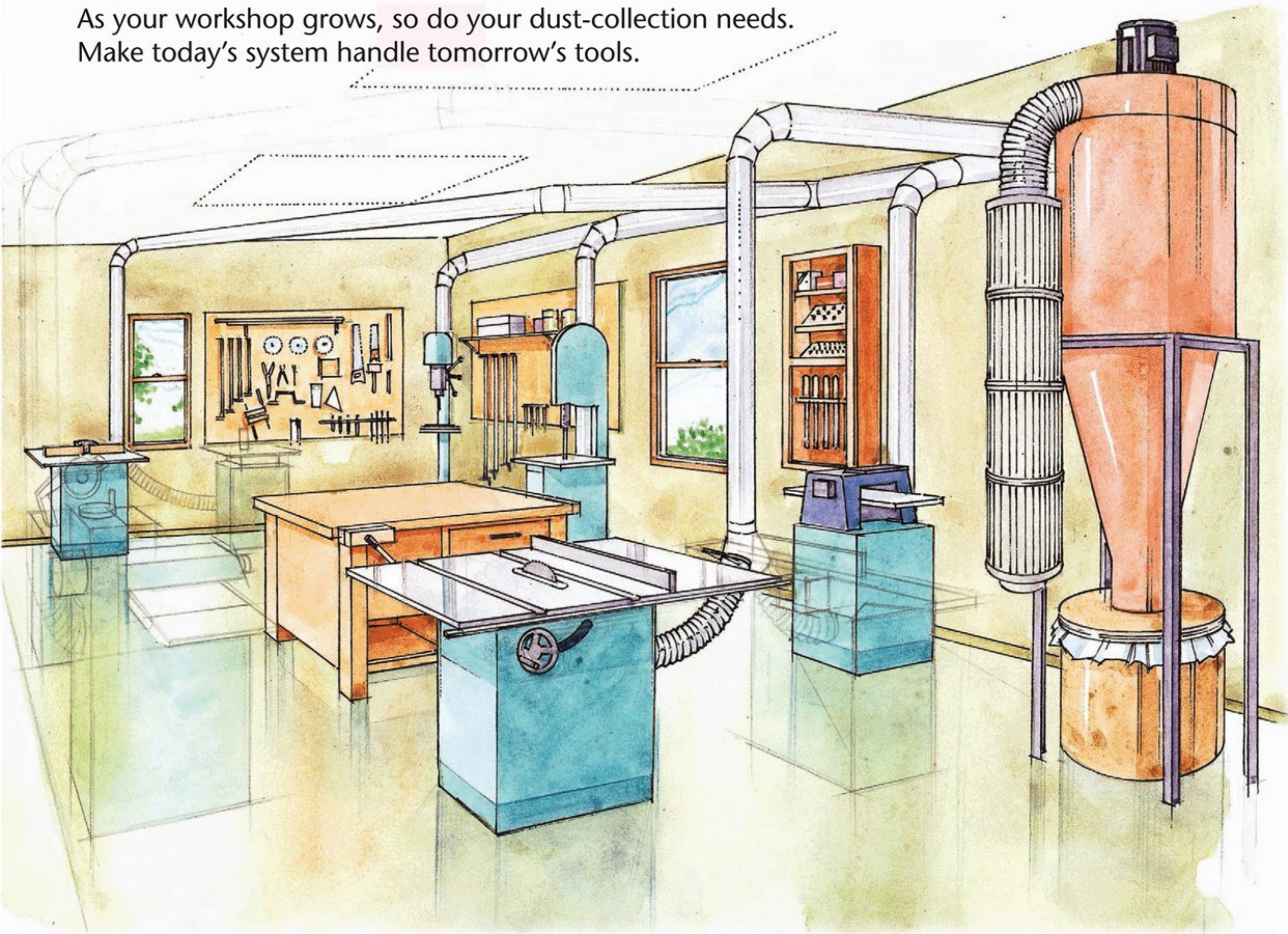

You know you need to upgrade your workshop dust-collection system when:

1. Your workspace looks like a shop-vacuum showroom, with a different one attached to each machine.
2. You postpone buying a jointer or planer because it would overwhelm your old vacuum or bury your shop in chips and dust.
3. If the dust in your lungs doesn't choke you, the people sharing your dust-filled house will.
4. All of the above.

Of course, a basic dust collector or cyclone plus ductwork can be installed for less than \$1,000 while high-capacity systems cost several thousand—not exactly chump change. So, if you're about to make that kind of investment, install a system that will serve you for years to come, even as your dust-collection needs change (and they surely will). You'll find the extra money will be well spent if you value:

Healthier lungs. Few shop-vacuum filters and single-bag collectors trap 0.3- to 5-micron dust particles—the stuff

that can lead to respiratory problems. (For the definition of "micron" and other dust-collection lingo, see the top of the *next page*.)

The option to add step-up tools, such as a 15" planer or 8" jointer, that need the power of a dust collector.

Less setup time and clutter. A ducted system eliminates tripping over extension cords and corrugated hoses, and repositioning a portable collector.

Convinced? Then start designing a system for both the shop you have today and the one you'll have tomorrow.

Learn the language of dust collection

Before shopping for a dust-collection system, familiarize yourself with a few of the common terms you'll encounter during your search.

Static pressure resistance. Before a system can carry away debris, air already filling the duct needs to be moved out of the way. That produces static pressure resistance measured in inches. Unnecessarily narrow ducts, sharp duct bends, and corrugated hose increase static pressure resistance by restricting airflow or adding friction between ductwork and the air.

Cubic feet per minute (cfm). Be careful how a manufacturer measures air-volume movement. Measurements taken on a "free air" basis—without any attachments that add static pressure or hinder airflow—help you compare one collector with another. But they're not a real-world measure of how a unit will actually perform when hooked up to a system that creates static pressure resistance. Measurements figuring in static pressure resistance better mimic collector performance when hooked up to ductwork and tools.

Drop. A duct descending from an overhead main duct or branch to connect to a tool; drops typically include a 45° wye for the main duct, a 45° elbow, vertical pipe, blast gate, and corrugated hose to attach to the tool. Some use a wye splitter to serve two tools.

FPM/air velocity. This is the speed of air, in feet per minute, moving through the ducts while the system is on. Aim for air velocities of 4,000 fpm in the drops, and 3,500 fpm in the main ducts.

Micron. In this unit of measure for dust particles, 397 microns equals 1/64".

Plan a system for your changing workshop

First, estimate the dust-collection needs of your future, expanded shop. Make a list of your existing machinery, and what you plan to buy within five years. In a typical home shop, you'll likely be working alone on one machine at a time with the others closed off by blast gates. If you plan to share your shop, you'll

need a collector large enough to serve machines working simultaneously.

Next decide how much your shop space might grow. Added space requires a more powerful collector to pull debris through longer ducts.

Then map your shop layout with the existing equipment as well as machinery

you'll add. To lay out your shop, use graph paper and paper cutouts to represent the size and shape of stationary tools; a computer modeling program such as Google SketchUp; or an online tool such as Grizzly Industrial's planner at grizzly.com, as shown below.

Dust-collector suppliers will often help you position the collector in the shop and lay out the ductwork efficiently. The service is free for purchasers of larger cyclones.

We worked with Penn State Industries (800-377-7297) to lay out a 16x24' sample shop, at left, that starts with a 10" table-saw, a bandsaw, a 12" planer, a drill press, and a router table. Future tools include a 6" jointer, 10" miter saw, 16" drum sander, and a belt/disc sander. Oneida Air Systems also offers a ductwork design service (800-732-4065, or oneida-air.com).

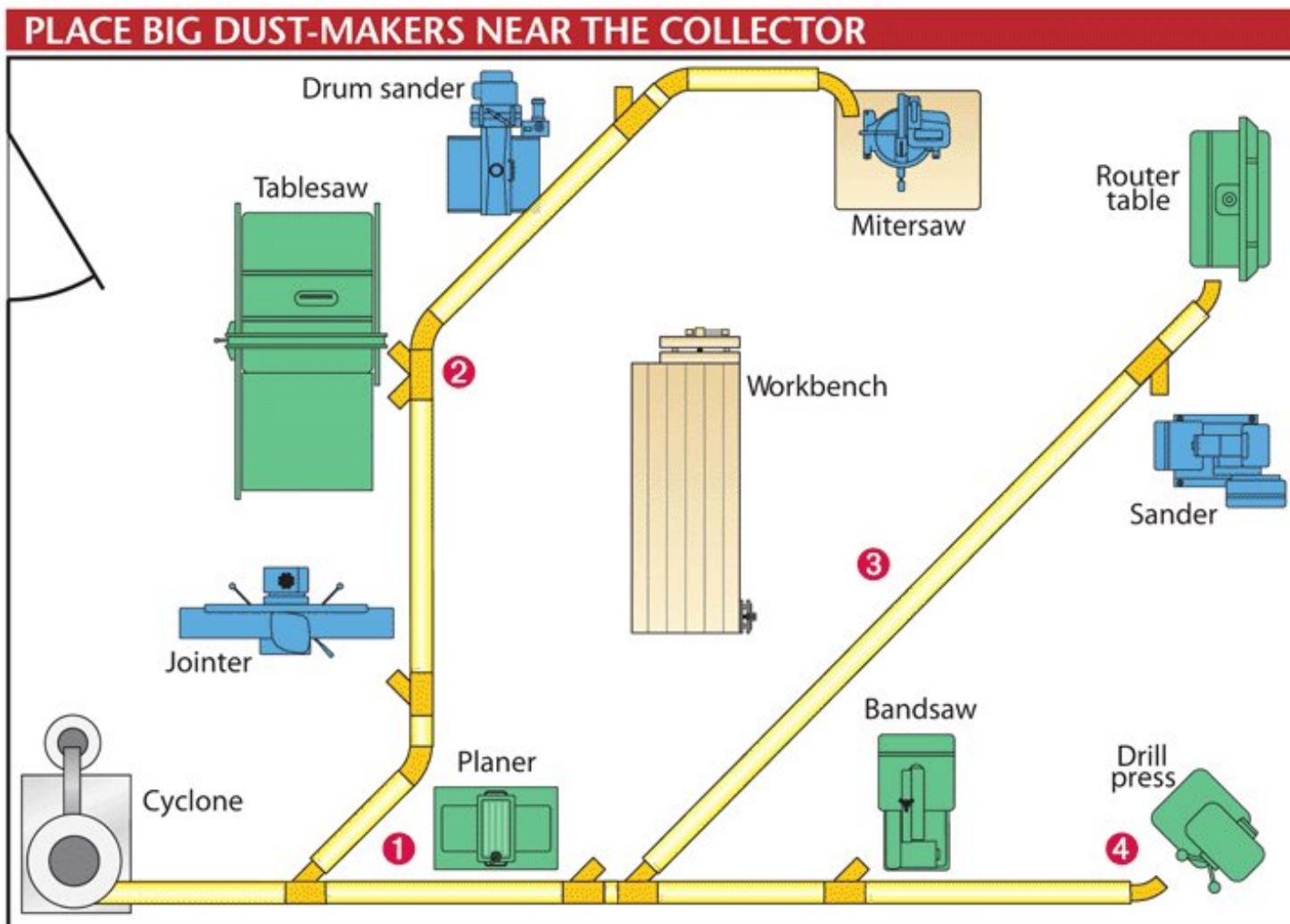

This system designed by Penn State Industries uses a 2.5-hp cyclone and 6" ducts leading to 4" drops that connect to the tools using short, flexible hoses. (Existing tools are shown in green, future tools in blue.) Economy ductwork and connectors, instead of spiral ductwork and premium connectors, cut the estimated price from \$2,403 to \$2,044. Features include:

- 1 The planer and (future) jointer both generate large amounts of dust and chips, so both are positioned as close as possible to the collector, where static pressure resistance is least.
- 2 The drop to the table saw splits into two hoses—one for the saw's dust port, and another for an aftermarket dust-collecting blade guard.
- 3 Diagonal runs cover a large portion of the shop for adding still more tools while minimizing the number of 90° connections.
- 4 Even the drill press connects to the system by way of a rigid adjustable hose that can be repositioned at the drill-press table as needed.

MAP YOUR SHOP BY COMPUTER



This online shop planner at grizzly.com lets you virtually arrange shop tools so you'll know where to run dust-collection ducts.

Ductwork dos and don'ts

To avoid common duct-design flaws:

DO use the largest ductwork that fits your collector. Just because a tool comes with a 4" dust port doesn't mean you should use 4" main ducts or drops. Instead, look at the intake port sizes for the collectors you're considering. Most cyclones have intake ports of 6" to 8", and some two-bag collectors have 5"- or 6"-diameter intakes, so consider at least a 5" main duct. Tapered reducers, like the one *below*, change duct diameters with minimal static-pressure loss.

DO smooth out sharp curves. Think of air molecules as fast-moving cars on a freeway. Both change direction faster on a sweeping curve than a 90° turn. The PVC tee shown at *near right* adds more

airflow resistance than the metal dust-collection pipe's gradual bend.

DON'T overuse flex hose. Corrugated tubing creates three times more static-pressure resistance than the same length of smooth pipe. Use just enough to link a tool to its drop pipe.

DO eliminate bottlenecks near the collector. (See "Give dust a straight shot to the collector" *below*.) Instead of two

90° bends, use two 45° bends. Better still, raise the collector until the main duct leads straight into the inlet.

DON'T create long duct runs. A single duct of 30' or more that wraps around more than two walls of a shop reduces air velocity and increases the risk of dust buildup. Instead, hang one shorter main duct, with diagonal branches leading to the tool drops.



This reducer connects to corrugated hose or narrower duct. Connecting clamps let you reconfigure this type of metal duct.

DANGER: CURVES AHEAD

POOR	BETTER	BEST
This PVC tee's sharp bend raises static-pressure loss by slowing airflow.	A more gentle arc creates less resistance, but you can do better.	A shallow bend reduces static pressure resistance and improves airflow.

GIVE DUST A STRAIGHT SHOT TO THE COLLECTOR

POOR	BETTER	BEST
Two 90° bends	Two 45° bends	Straight pipe

The 90° elbows in the dust-collector setup (*left*) add turbulence and resistance. Two 45° bends (*center*) reduce resistance, but a straight run into the inlet port (*right*) works best.

Buy enough suction power

To choose a dust collector that will handle your shop's future requirements, you first need to know which tool in your shop (or on your shopping list) needs the greatest airflow to pull away dust and chips. Because every foot of pipe and each fitting adds resistance to that airflow, you also need to know the amount of static-pressure loss between the collector and that tool. With your workshop layout and dust-collection system map in hand, use the charts on the *next page* to guide you from your floor plan to the collector you need.

Once you have both numbers, you're ready to shop. Skip references to "free

air" or "maximum" cfm, and check manufacturers' literature and Web sites for performance curves like the example at *right*. (For head-to-head comparisons of several manufacturers' products, go to woodmagazine.com/cyclones.)

Manufacturers' curves may show how the system performs under ideal, carefully controlled conditions with a new, clean filter. Time and real-world use may lower a unit's actual performance, so opt for the next collector size up from what you've calculated you'll need. That way, no matter how far woodworking takes you, it won't leave a trail of sawdust along the path.

GRADE COLLECTORS ON A CURVE

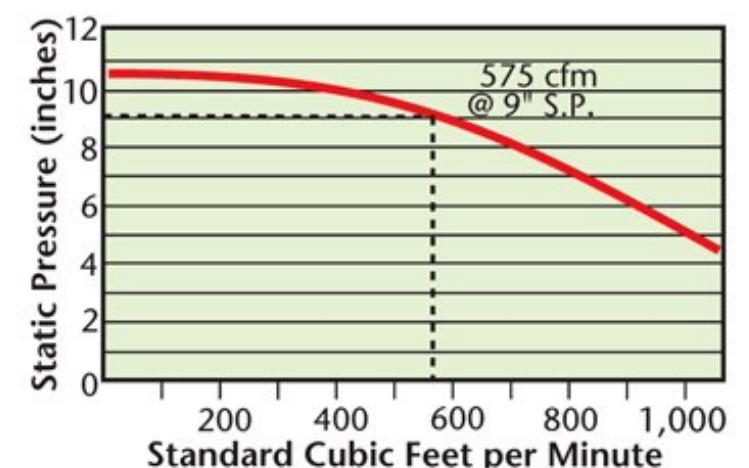

Trace a horizontal line from your system's static-pressure total (9" in this example) and a vertical line up from your most-demanding tool's CFM requirement (575 cfm). If they meet on or under the curve, that collector has the power you need.

Estimate your dust-collection needs

Begin here

Estimate airflow needs

Find the tool you own (or will add) with the highest cfm requirement. Write the cfm on line 1 below. Your system needs to meet this peak cfm. If you'll use more than one tool at once, add the two numbers.

Tool	Duct	cfm
Bandsaw	4"	350
Belt/disc sander	4"	550
Drum sander (12–24" drum)	5"	550–650
Jointer, 6–8"	4"–5"	350–550
Planer, 10–15"	3"–5"	500–600
Planer, >15"	6"	700–800
Radial-arm saw/mitersaw	5"	550
Router table/shaper	4"–5"	350–550
Tablesaw	5"	550

1 Maximum cfm:

Estimate your ductwork

Now that you know your maximum cfm needs, use that number to total the feet of ductwork required to connect the collector to the most-demanding tool (or tools). Circle the maximum cfm number from Step 1 in each of the cfm columns below, rounding up, if necessary. The duct size shown on the same line as the cfm you circled under "main" is the size you need for your main duct. The circled cfm under "branches" tells the duct diameter leading to individual tool drops. Now measure how many feet of each size you need to connect your dust collector to the tool, and write those lengths in the spaces on the right.

Main	Branches	Duct Size	Number of Feet Needed
170	195	3"	
300	350	4"	
475	550	5"	
700	785	6"	
950	1,100	7"	
1,200	1,400	8"	

Add up duct static pressure losses

Now translate the main and branch duct length into static pressure (SP) losses. Multiply the number of feet of duct by that size's SP loss per foot. Add up the numbers in the right column, and transfer the total to the next box.

Duct Size	No. of Feet	Static Pressure Loss per Foot	Total Static Pressure Loss (")
3"	×	0.1	= "
4"	×	0.07	= "
5"	×	0.055	= "
6"	×	0.045	= "
7"	×	0.038	= "
8"	×	0.032	= "
Total Ductwork Static Pressure Resistance:			"

Add resistance from system parts

You're almost finished. For each duct diameter between the collector and the most-demanding tool, record the number of 45° elbows, 90° corners, and feet of flex hose. Next, add up the totals for each row, and multiply those by the SP values in the far right boxes. Add the subtotals down, and add the total SP loss from the box on the left, and write the total maximum static pressure resistance on line 2. This, along with the maximum cfm from line 1, are the two numbers you'll need to shop for a collector that meets your tool and system needs.

Fitting Diameter	45° Elbows	90° Corners	Flex Hose	Totals × SP (")
3"	_____ × 2.5 = _____	_____ × 5 = _____	_____ × 3 = _____	_____ × .1 = _____ Subtotal: _____
4"	_____ × 3 = _____	_____ × 6 = _____	_____ × 3 = _____	_____ × .07 = _____ Subtotal: _____
5"	_____ × 4.5 = _____	_____ × 9 = _____	_____ × 3 = _____	_____ × .055 = _____ Subtotal: _____
6"	_____ × 6 = _____	_____ × 12 = _____	_____ × 3 = _____	_____ × .045 = _____ Subtotal: _____
7"	_____ × 6.5 = _____	_____ × 13 = _____	_____ × 3 = _____	_____ × .038 = _____ Subtotal: _____
8"	_____ × 7.5 = _____	_____ × 15 = _____	_____ × 3 = _____	_____ × .032 = _____ Subtotal: _____
Non-Duct Static Pressure:				
Total Ductwork Static Pressure Resistance:				
2 Total Static Pressure:				

Sources

Dust collectors, ductwork, and system design assistance: Grizzly Industrial, 800-523-4777 or grizzly.com. Oneida Air Systems, 800-732-4065 or oneida-air.com. Penn State Industries, 800-377-7297 or pennstateind.com.

3 Kitchen Clutter Busters

Make the cook's life easier with a trio of projects you can build in a weekend.



These small projects solve big storage problems in your kitchen—jumbled silverware drawers, inaccessible base cabinets, and clattering stacks of bakeware. We built each one to fit the drawers and cabinets in the kitchen remodel

featured in issue 196 (see **More Resources**). But you can quickly resize them or customize them to fit your kitchen and your storage needs using the instructions in this article. Basic tools and a few scraps of stock will get the job done.

1 Bring drawer disorder to a close

Store-bought kitchen drawer organizers separate silverware—most of the time. But the organizer you design and build works all of the time because you customize it for the size and number of knives, forks, spoons, and accessories *you* use.

Organizer sizer. Measure the drawer interior and design your organizer's outside dimensions $\frac{1}{4}$ " smaller to allow for easy removal of the tray for cleaning. Make it just tall enough to hold the utensils. Then decide how many types of forks, spoons, knives, and accessories you'll store. Make silverware dividers about $\frac{1}{2}$ " longer than the longest piece of silverware.

Build to your dimensions. Prepare enough $\frac{1}{2}$ "-thick stock to make the front, back, sides, and partitions. Cut all parts to width; then the sides to length. Now cut the front, back, and



AFTER: SIZED TO SUIT YOUR SILVERWARE



BEFORE: STICK A FORK IN IT; IT'S DONE

Compartments keep silverware organized, with infrequently used items at the back of the drawer and everyday utensils in front.

A one-size-fits-all organizer didn't fit this drawer's contents. If anything, it encouraged clutter by overstuffing the drawer.

1 SILVERWARE DRAWER ORGANIZER

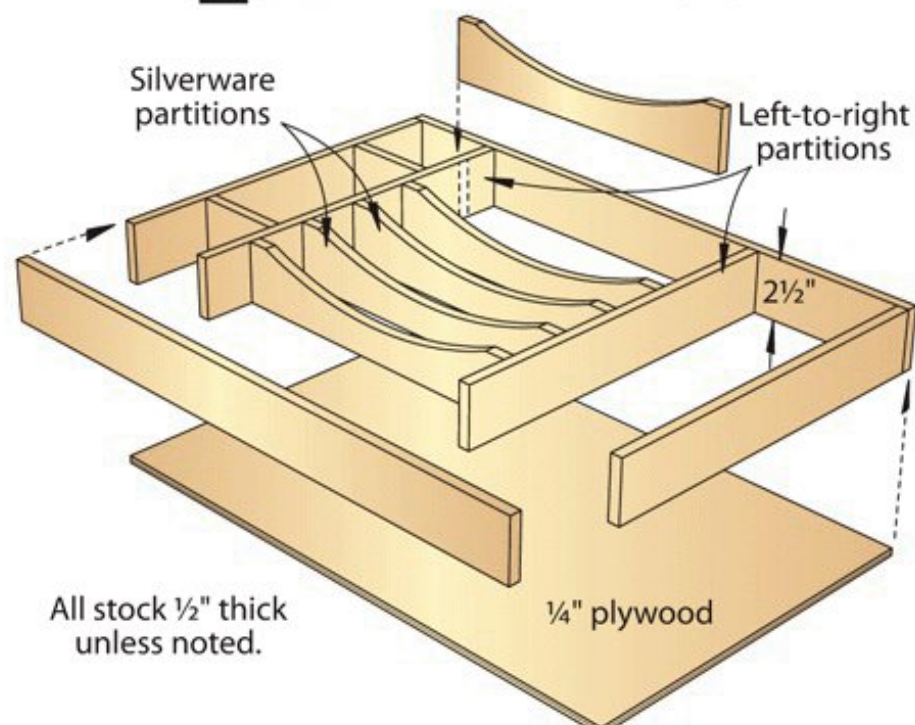

All stock $\frac{1}{2}$ " thick unless noted.

$\frac{1}{4}$ " plywood

two left-to-right partitions 1" shorter than the outside width of the organizer. Cut to length the front-to-back partitions separating the silverware. To make items easy to reach, mark a centered, curved cutout on each partition using a compass or fairing stick. (See **More Resources** for how to make and use your own fairing stick.) Bandsaw on the waste side and sand to the line.

Quick Tip: Combine your cuts. Instead of cutting each curve separately, tape together a stack of identical blanks and lay out the curve on the top blank. Then bandsaw and sand the stack to create parts with identical curves.

Dry-assemble the organizer with the silverware partitions and left-to-right partitions in place, and measure for optional partitions at the front or back. Cut these to size and double-check the fit. Then finish-sand the partition parts to 180 grit.

Working on a dead-flat surface, glue and clamp the silverware partitions to two left-to-right partitions, as shown *above right*. (To shorten clamp times, use a nailer with 1" brads.) To this assembly, glue, clamp, and nail the sides, front, back, and remaining partitions. After the glue dries, measure the assem-

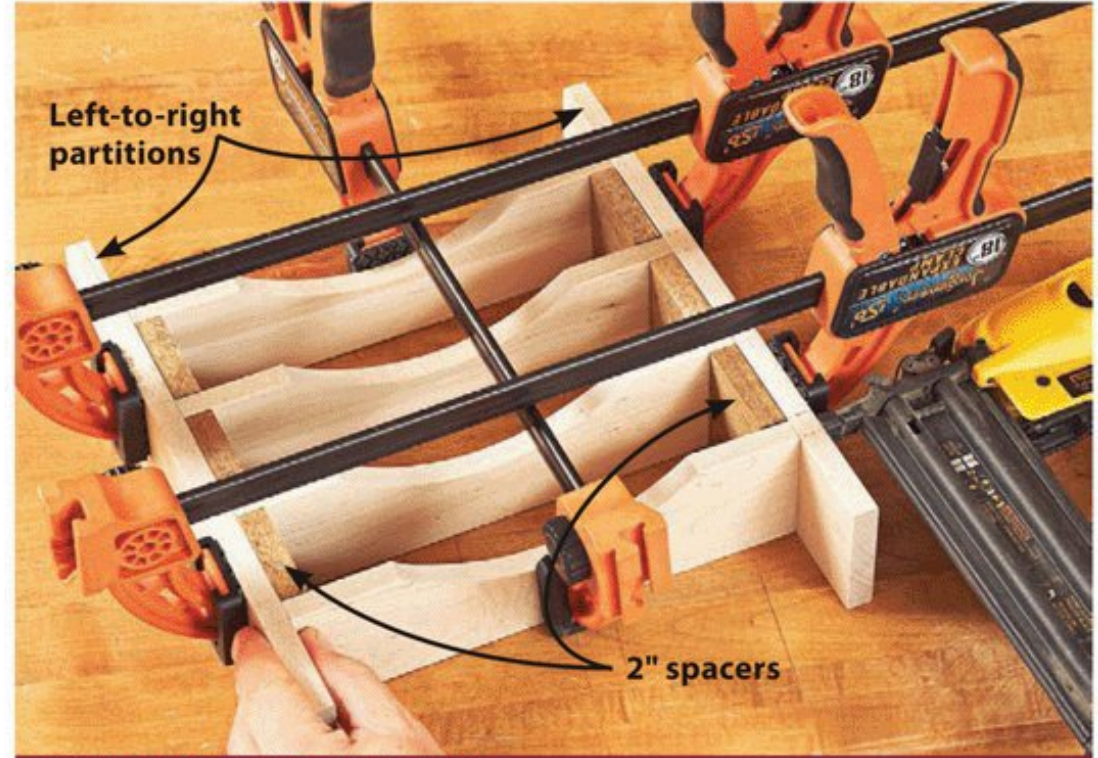

SPLIT UP THE GLUE-UP

Spacers between the silverware partitions keep the left-to-right partitions 90° to the tray bottom.

bly length and width, and cut a bottom to size from ¼" plywood. Glue, clamp, and nail the bottom to the assembly. Then apply three coats of clear finish, such as polyurethane.

2 Base-cabinet contents come to you

When half of a cabinet's contents prove so hard to reach that they might as well be in the garage, it's time to take back control. Sliding drawerlike trays that extend the depth of a cabinet bring even the stuff at the back out where you can see and reach it.

Organizer sizer. First measure the width of each base cabinet face-frame opening and subtract 1". Then measure from the inside of the face frame to the cabinet back (usually about 23"). Size the overall tray length ½–1" shorter than the cabinet depth. We designed our trays with 2½"-wide sides, fronts, and backs [Drawing 2].

Build to your dimensions. Cut the tray sides to length and the fronts and backs 1½" shorter than the tray width you calculated. Cut the front faces ¼" shorter than the width of the opening in the cabinet frame.

Next dado the inside faces at both ends of the tray sides, as shown in Step 1 of **Drawing 3a**. Then cut mating rabbets on the ends of the fronts and backs, as shown in Step 2. Cut grooves in the front, back, and sides for the tray bottom. Measure between the bottoms of the grooves and cut the tray bottom to fit within the grooves. Assemble the tray and finish-sand to 180 grit. Stain the front face to match your cabinets and apply three coats of clear finish. (We used satin aerosol lacquer, sanding with a 320-grit sponge between coats.)

2 PULL-OUT CABINET TRAY

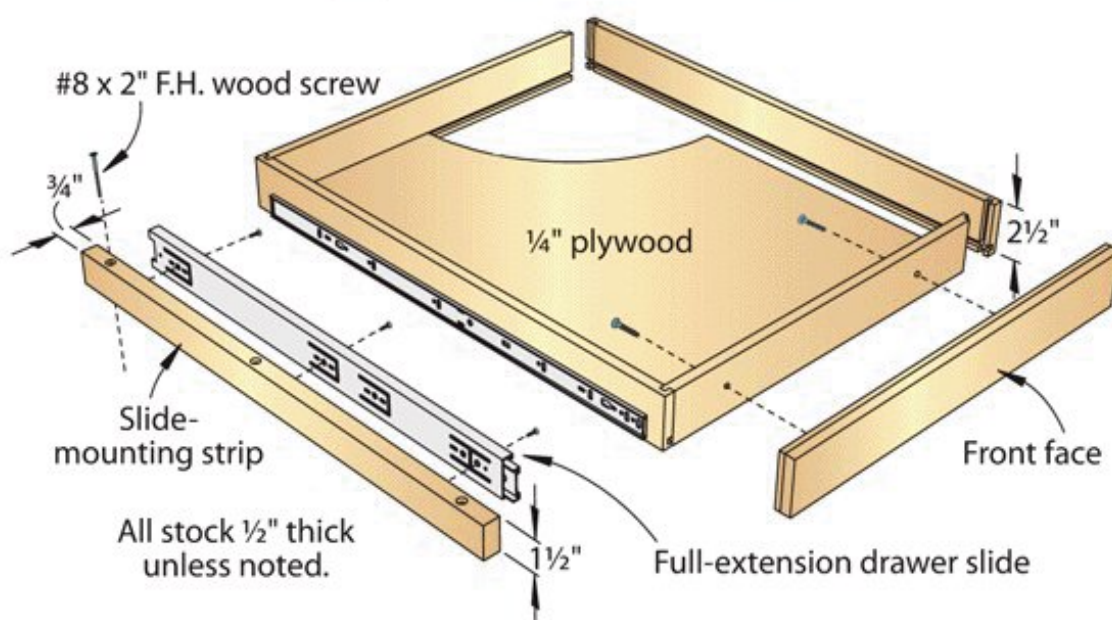

woodmagazine.com

AFTER: SLIDING TRAYS DO THE WORK IN THIS CABINET



BEFORE: REACH FOR IT



Full-extension slides bring the entire tray out into the open. We added trays to only the fixed shelf on these cabinets because hinges would have blocked trays on the bottom. But your cabinet doors may allow stacked trays on both the shelf and cabinet bottom.

Bending and stretching to retrieve contents from the back of these cabinets was literally a pain in the neck!

Now put it to work. Choose the longest slides that fit the depth of your cabinet. To use 22" side-mounted, full-extension slides (see **Source**), first install mounting strips running from the front to the back of the cabinet sides. See "How to make organizers ride on slides" on *page 65* for installation tips. Install both tray-mounted slide parts flush with the bottom edge of the tray sides. Mount the tray in the cabinet and check that it slides smoothly.

Next apply double-faced tape to the tray front face. Center the front face in the opening with ⅛" reveals on both sides and above the rail or shelf edge. Then drill and screw through the tray front to mount the front face.

3 Tame the cookie-sheet monster

If pulling out a pan from your bakeware stack sounds like a five-car pileup, restore calm to the kitchen with a sliding cookie-sheet organizer built for your needs. Then hide it by attaching a new or existing cabinet door to its front.

Organizer sizer. Make the total width 1" narrower than the face-frame opening to allow clearance for the slides. This organizer's height can be anything up to the height of the face-frame opening, although we made ours about 4" shorter to save material. Make the overall organizer length about 1" less than the cabinet depth.

Build to your dimensions. Attach solid-wood or iron-on edging to 3/4" plywood for front and back panels the width of your finished organizer. Then subtract the combined thickness of the panels from the length of the organizer. Cut the six rails that length from 3/4x2"-wide stock for the upper rails and 3/4x3"-wide stock for the bottom rails. Now cut the plywood bottom to the same length as the rails and the width of the front and back panels, as shown *below*.

Dry-assemble the organizer with the rails and bottom butt-joined to the front and back, and drill countersunk pilot holes in the front and back. Glue and screw the front and back to the rails. Now glue the bottom to the bottom-rail edges. Finally, cut slide-mounting rails the length of the organizer and glue and screw them to the bottom.

Now put it to work. Attach slide-mounting strips to the sides of the cabinet as explained in "How to make organizers ride on slides," *opposite*. Then screw slides to the slide-mounting strips and the slide-mounting rails on the organizer.

We made a new door for the cabinet shown *right* as part of the kitchen remodeling, but you can mount an existing door



AFTER: PANS STAND READY
Position the rails to support your flat pans, cookie sheets, and cutting boards. The bottom rails act as the sides of a long tray.



BEFORE: PAN-DEMONIUM
We have no idea why this door had two knobs. They didn't prevent a pan jam.

3 SLIDING COOKIE-SHEET ORGANIZER

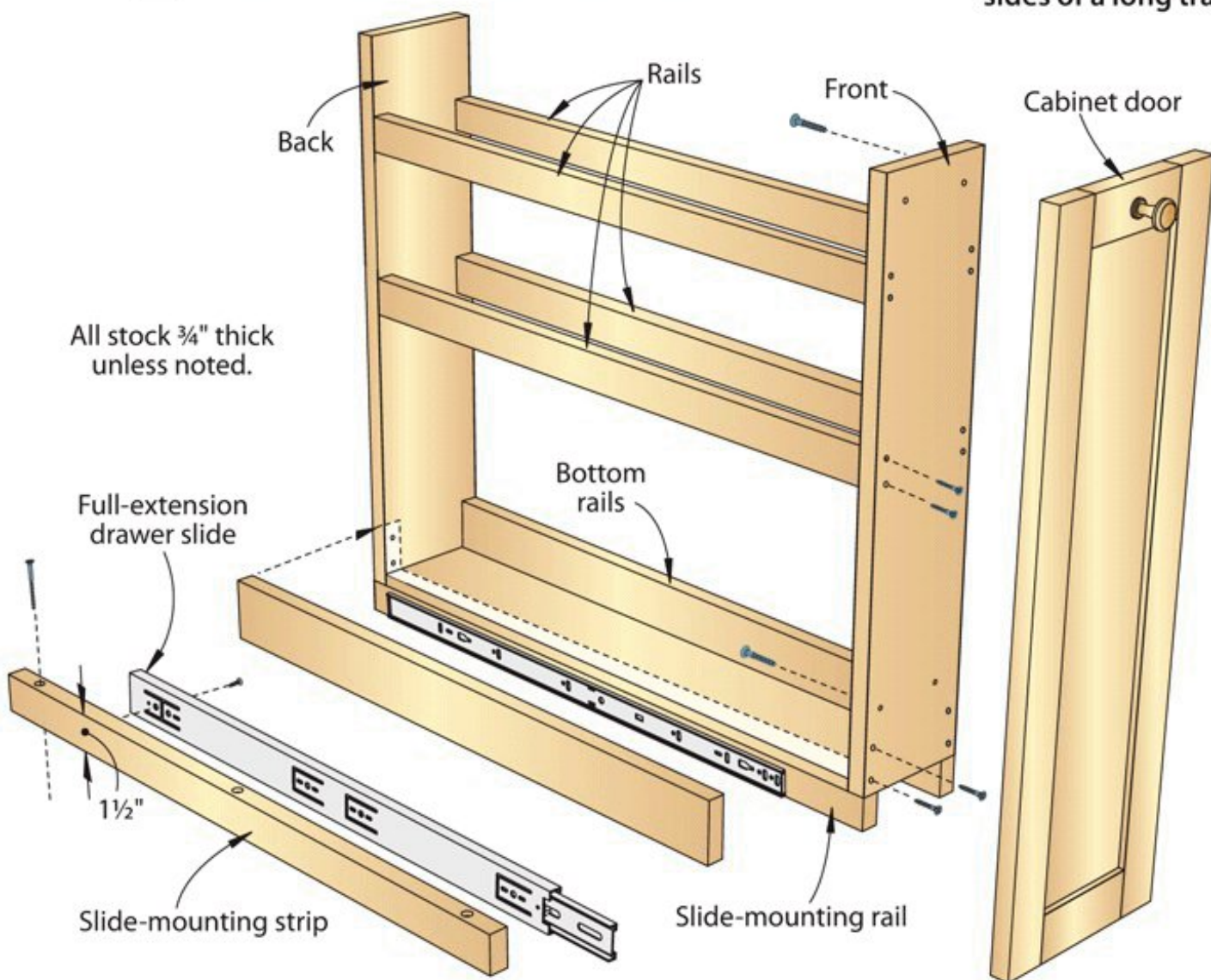

on the organizer just as easily after removing its hinges. With the organizer in place, tape a scrap spacer to the back to bump the front just proud of the cabinet face frame. Then place double-faced tape on the organizer front, center the door on the face-frame opening, and press it against the tape. Drill and screw through the organizer and into the door. Then stand your bakeware on edge in the organizer with the shortest pieces to the outside for easy reach.

Use Step 1 to dado both ends of each tray side. For Step 2, tape a 1/4"-thick shim to the rip fence and rabbet both ends of each tray front and back.

3a HOW TO CUT LOCK-RABBET JOINTS ON A TABLESAW

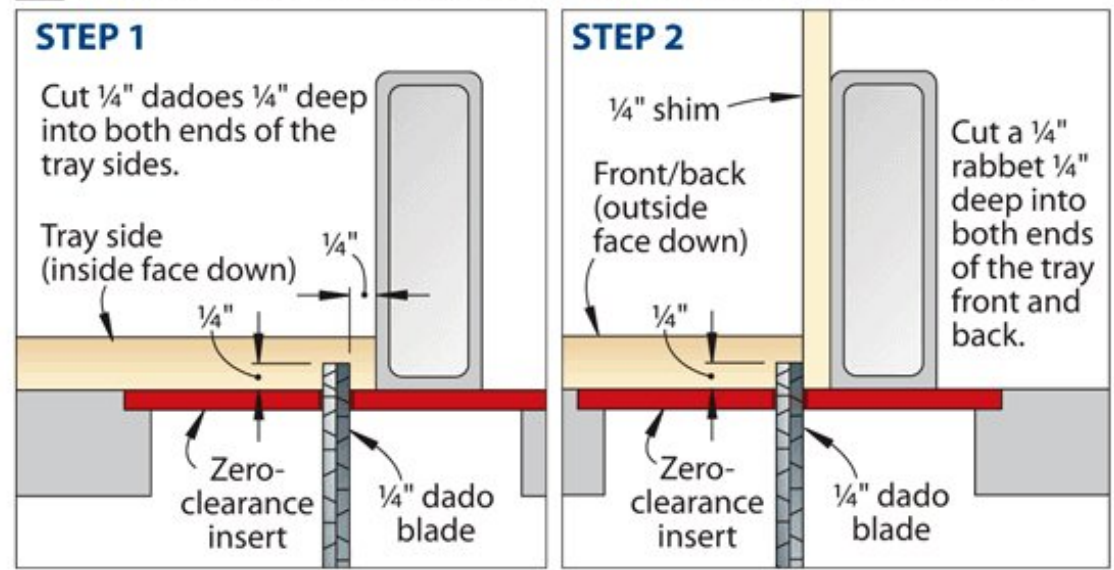

How to make organizers ride on slides

Both the slide-out trays and the cookie-sheet organizer require full-extension, side-mounted slides (see **Source**) that attach to your cabinets. The cabinet-mounted part of each slide first requires slide-mounting strips.

■ For a single-door base cabinet, cut two strips 2½" wide and plane them to fit flush with the face-frame stiles, as shown *far right*. Screw the strips to the cabinet sides with their bottom edges on the cabinet bottom.

■ For a double-door cabinet with a center stile, as shown on *page 63*, first mount strips inside the cabinet as in a single-door cabinet. From ¾×2½" hardwood, cut two slide-mounting strips that reach from the inside face of the center stile to the cabinet back.

From ¾"-thick hardwood, cut two spacer blocks to a width equal to the width of the cabinet's center stile minus 1½". Then cut both blocks 2½" long.

Center, drill, and screw a spacer block to the center stile at the bottom. Measure from the cabinet side to the center-stile spacer block and screw another spacer

block to the cabinet back that distance from the side. Drill and screw slide-mounting strips to the front and back spacer blocks, as shown *below left*.

CENTER-STILE SLIDE MOUNT

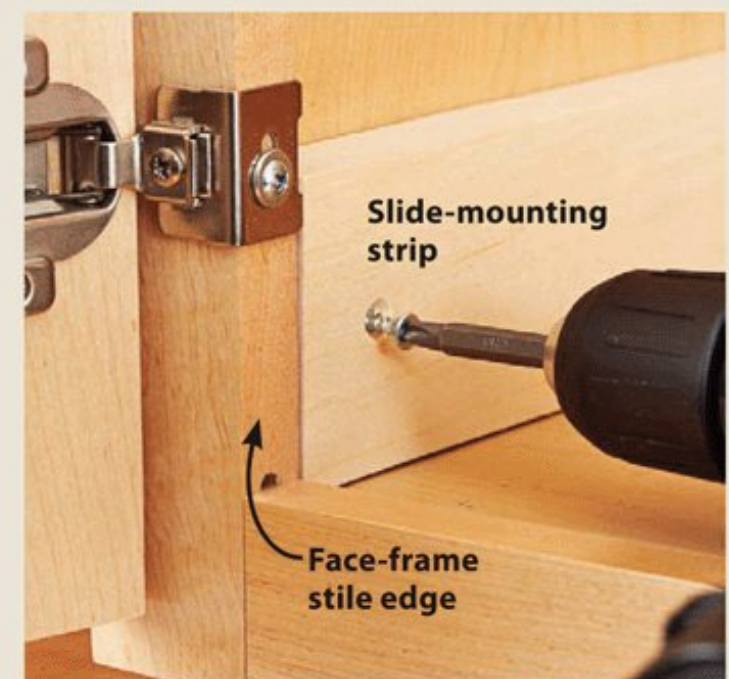
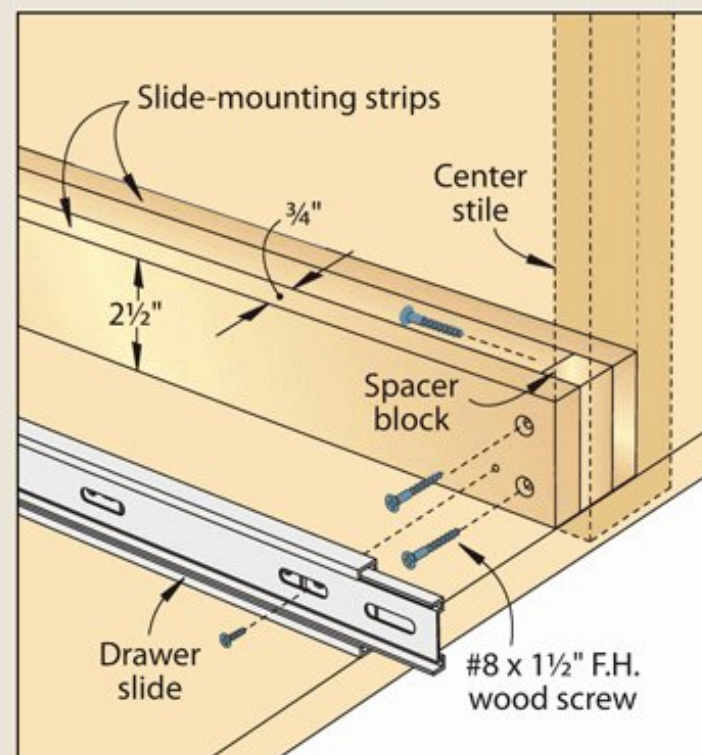

A slide-mounting strip allows slides on the sides of a tray to clear the face-frame edge.

MORE RESOURCES

FREE VIDEO

■ "Making Super-Simple Drawers"
woodmagazine.com/simpledrawer

FREE PLANS

- "Right-Angle Clamping Jig"
woodmagazine.com/anglejig
- Instructions for making a fairing stick
woodmagazine.com/fairing
- "Portable Drum Sander"
woodmagazine.com/drillsand

RELATED ARTICLES

■ "Cook Up a Kitchen Makeover in Your Shop" Issue 196 (March 2010) or at [\\$](http://woodmagazine.com/kitchenredo)
(*\$*—Download this article for a small fee.)



Written by **Bob Wilson** with **Kevin Boyle**
Project designs: **Kevin Boyle**
Illustrations: **Roxanne LeMoine; Lorna Johnson**

Source

Drawer slides: 22" 100-lb, full-extension drawer slides no. 02K30.22, \$14.50 per pair, Lee Valley Tools, 800-871-8158 or leevalley.com.

One-Stop Storage Drill- and Router- Bit Case

Organize and protect your bits with a cabinet that adapts to your needs.



PROJECT HIGHLIGHTS

- Overall dimensions: 24¼" wide × 9⅝" deep × 36" high.
- Customize the interior by varying the number of shelves and bit holders to suit your collection.

Skill Builders

- Learn how to make a simple and sturdy face frame and case door frame using half-laps cut with a dado blade.
- Discover how to pack the most bits into the smallest space.

A few hours spent building this wall-hung unit saves a lifetime of hunting for bits. Quickly find what you need with a glance through a clear acrylic door that keeps out dust.

Build the case

1 From ¾" plywood, cut the sides (A) and top/bottom (B) to size [Materials List, page 70].

2 With a dado blade the width of the plywood thickness, cut a ⅜"-deep dado on the inside face of a side (A) at the top and bottom [Drawing 1, Photo A]. Repeat for the other side.

3 Set your tablesaw fence to ¾" from the blade and cut a groove in the sides (A) and top and bottom (B) [Drawing 1] to the thickness of the back (C). (Ours was ⅜" thick.) Adjust the fence

CUT DADOES IN THE CASE SIDES

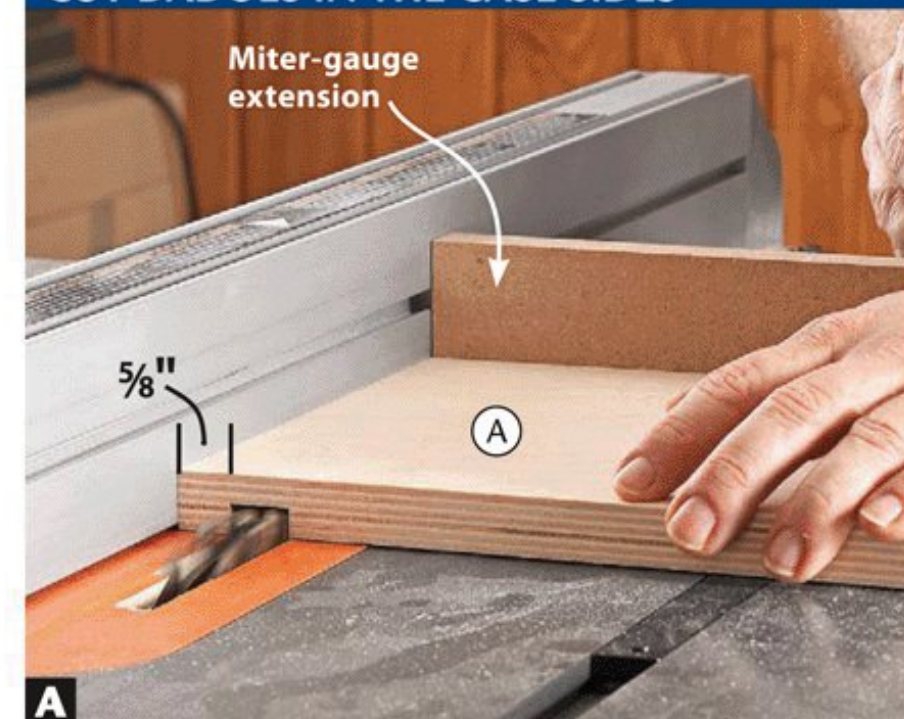

To prevent tear-out, back up dados cut in the sides (A) with a miter-gauge extension.

ASSEMBLE THE CASE

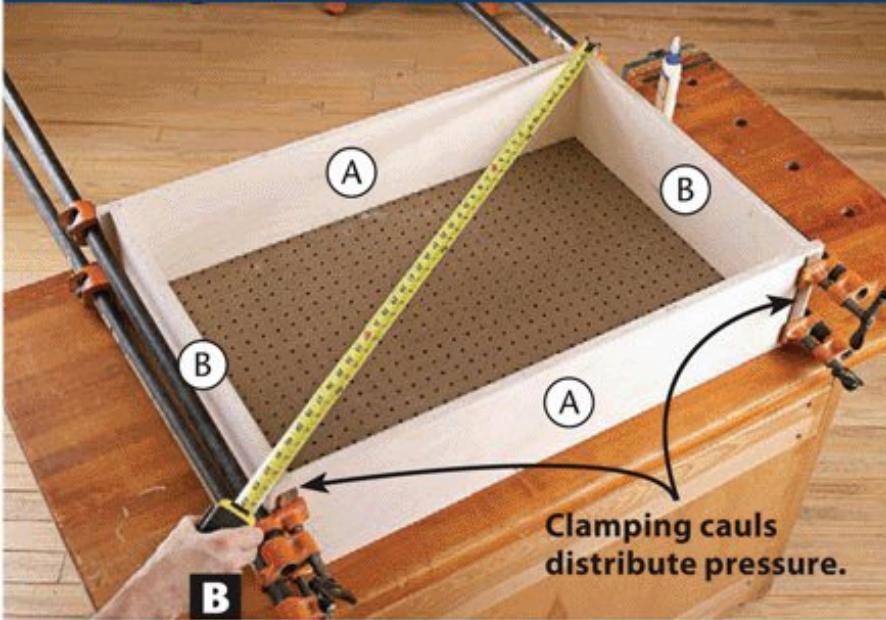

Measure between diagonal corners after attaching clamps. Equal distances mean the case is square.

DRILL SHELF-PIN HOLES

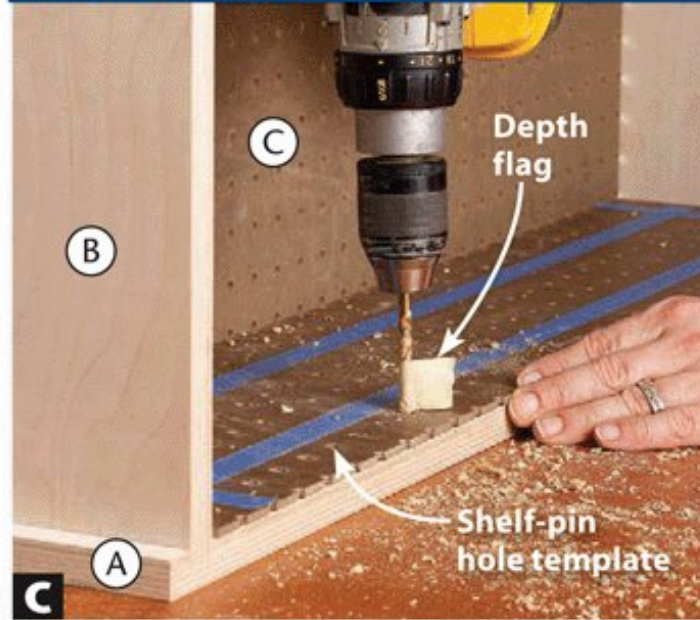

Tape along rows of holes shows where to drill shelf-pin holes into the sides (A). Also, tape on the bit indicates the drilling depth.

DADO DEAD-ON HALF-LAPS

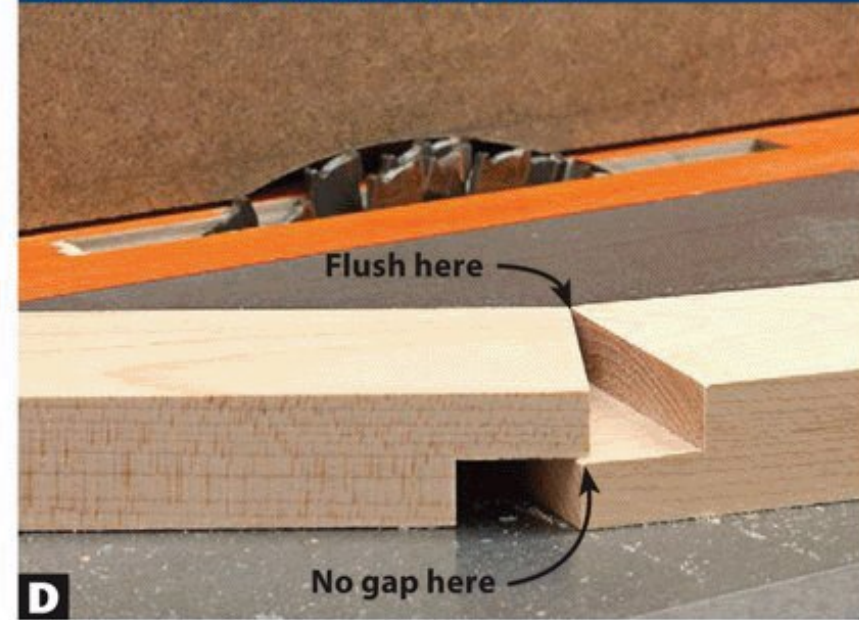

Test half-laps on scraps the same thickness as the frame rails (D) and stiles (E) until the surfaces fit flush with no gaps.

and make two or more passes as needed. Finish-sand the parts to 180 grit.

4 Cut the back (C) to size. Glue and clamp the sides (A), top and bottom (B), and back [Photo B].

5 Cut a shelf-pin hole template to size [Drawing 1a] from perforated hardboard. Apply masking tape to identify where to drill shelf-pin holes, and label the front and bottom edges. Add $\frac{3}{8}$ " to the template thickness; then wrap tape on a $\frac{1}{4}$ " bit that distance from the end as

a visual depth gauge. (See a free video of this at woodmagazine.com/shelfholes.)

6 With the case on its side, place the template bottom against the case bottom (B) and the front flush with the case front edge. Drill shelf-pin holes [Photo C], then repeat on the other side.

Dado the half-laps

1 Cut the face-frame rails (D) and stiles (E) to size. Then, cut the door rails (F) and stiles (G) to size, and put them aside.

2 Install a $\frac{3}{4}$ " dado-blade set to cut half the thickness of the face-frame parts [Photo D] and door-frame parts.

3 Set the rip fence to the width of the face-frame parts [Photo E]. Cut half-laps on the inside faces at both ends of the rails (D), and the outside faces at both ends of the stiles (E) [Drawing 2].

4 Now retrieve the door rails (F). Set the tablesaw fence to the width of the stiles and rails, as for the face frame. Cut 2"-wide half-laps on the inside faces at both ends of each rail, but not on the stiles (G).

5 Attach an auxiliary rip fence [Photo F], and cut a $\frac{3}{8}$ " rabbet $\frac{1}{4}$ " deep on the inside edges of the door rails (F) and stiles (G).

1 SIDE

(Inside face of left side shown)

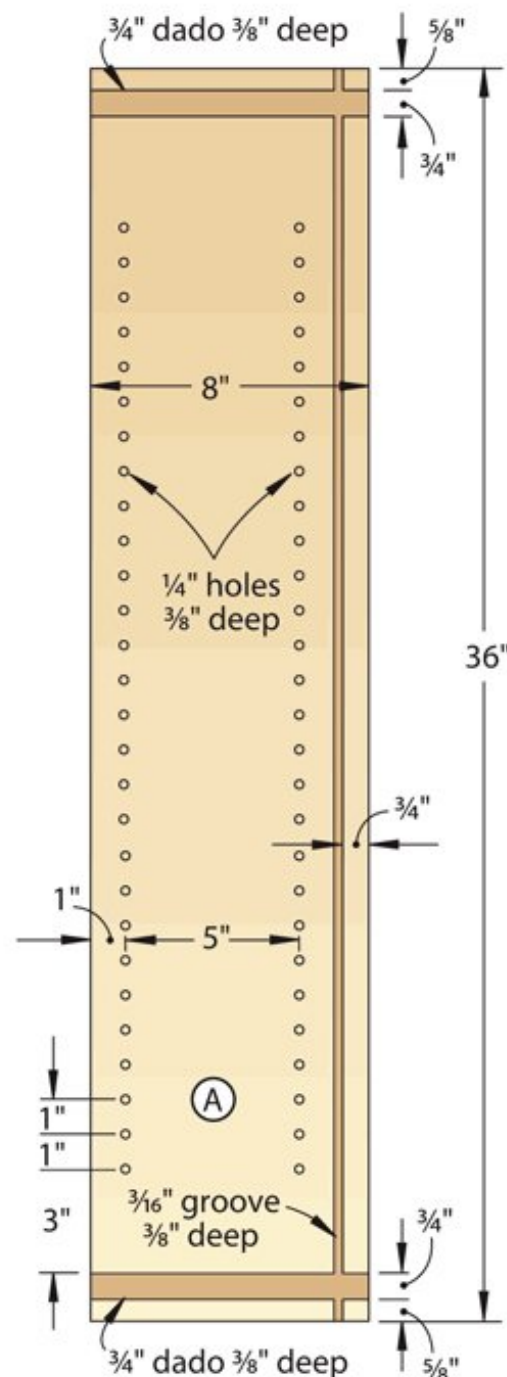

1a SHELF-PIN HOLE TEMPLATE

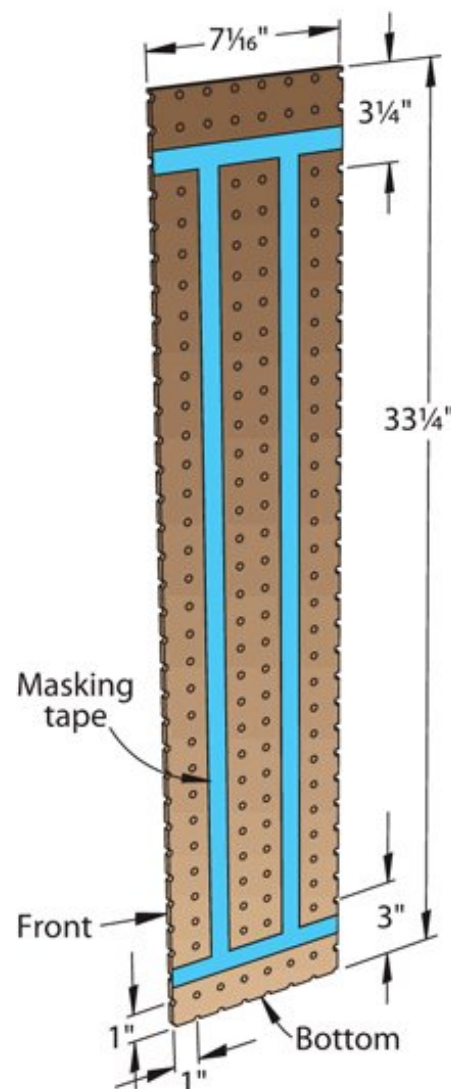

PARTS DICTATE HALF-LAP WIDTHS

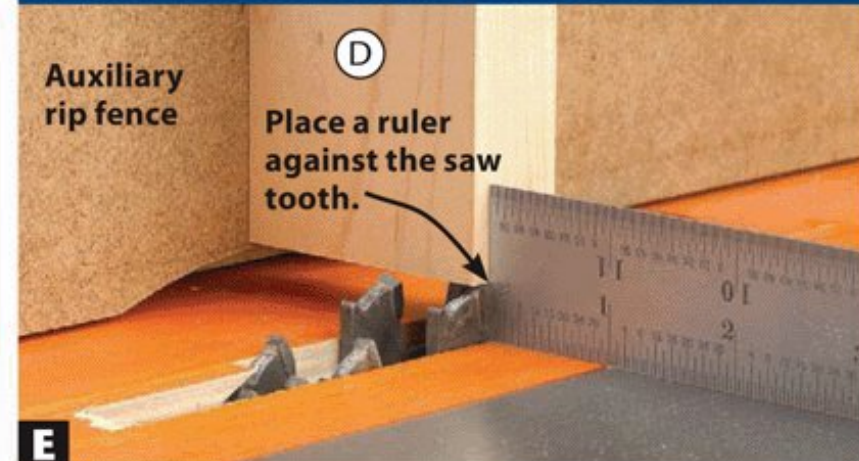

To set the half-lap width, place a ruler against an outside-cutting tooth, and then insert a face-frame part between the ruler and fence.

RABBET THE DOOR FRAME

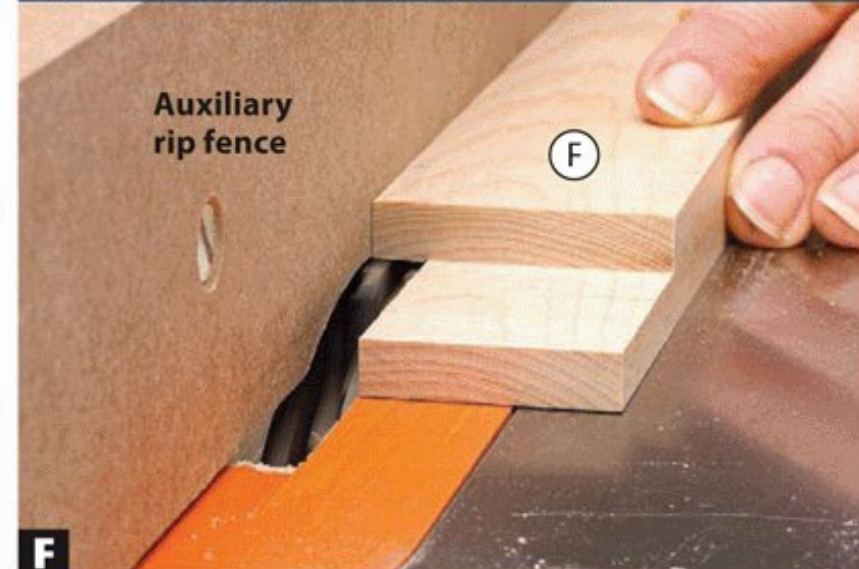

With the dado blade partially housed in an auxiliary rip fence, rabbet the door rails (F) and stiles (G).

2 EXPLODED VIEW

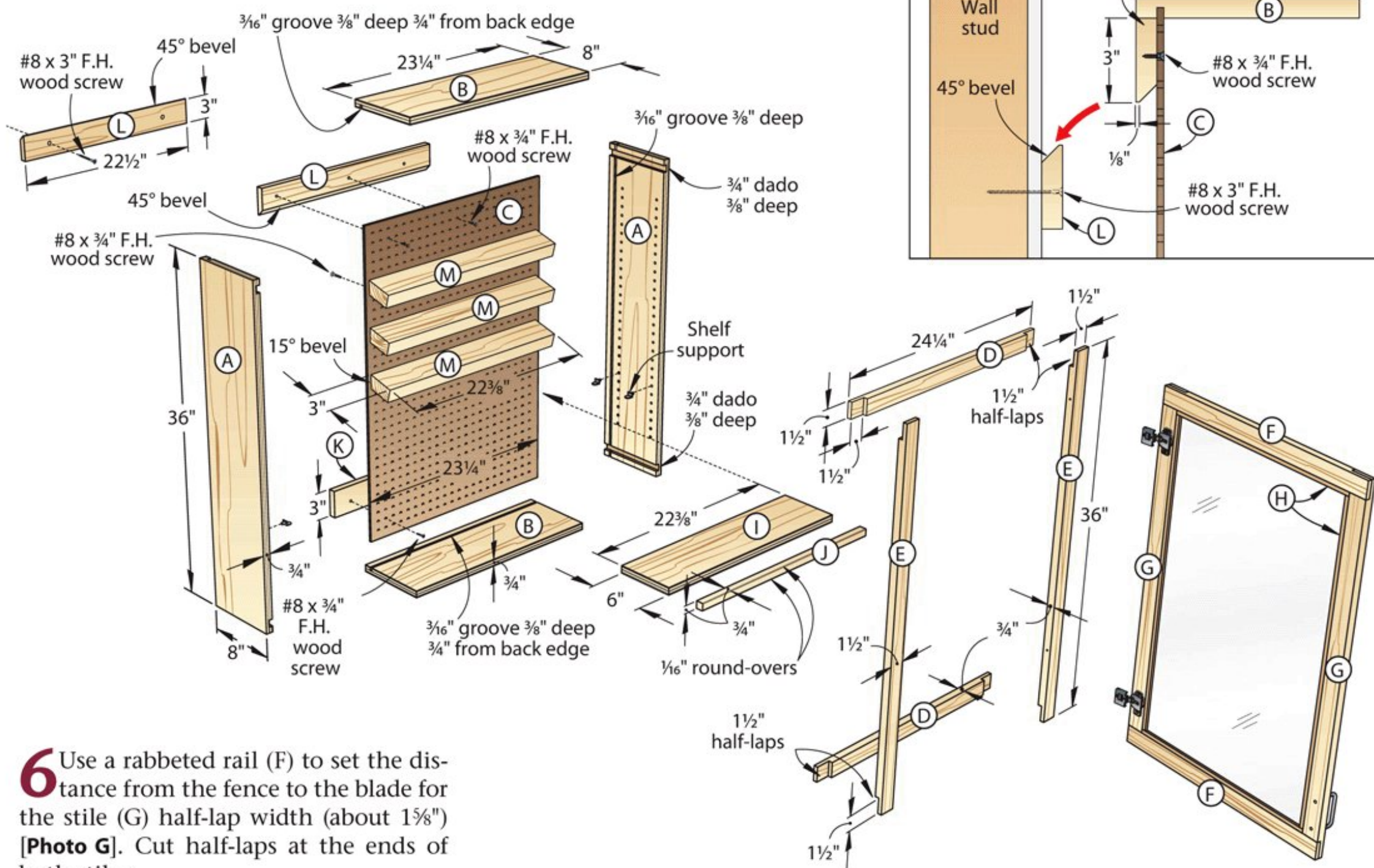

6 Use a rabbeted rail (F) to set the distance from the fence to the blade for the stile (G) half-lap width (about $1\frac{5}{8}$ " [Photo G]. Cut half-laps at the ends of both stiles.

Assemble the face frame and the door

1 To attach the face frame, first glue and clamp a rail (D) centered on the width of the case and flush with the ends

of the sides (A) [Photo H]. Then, glue and clamp both stiles (E) and the other rail (D) to the case, checking for even overhangs [Photo I]. Finish-sand the face frame to 220 grit.

2 To assemble the door, glue and clamp the rails (F) and stiles (G) [Drawing 3], checking for square. Cut a piece of $\frac{1}{8}$ " clear acrylic to fit the rabbeted opening and set it aside.

CUT DOOR STILE HALF-LAPS

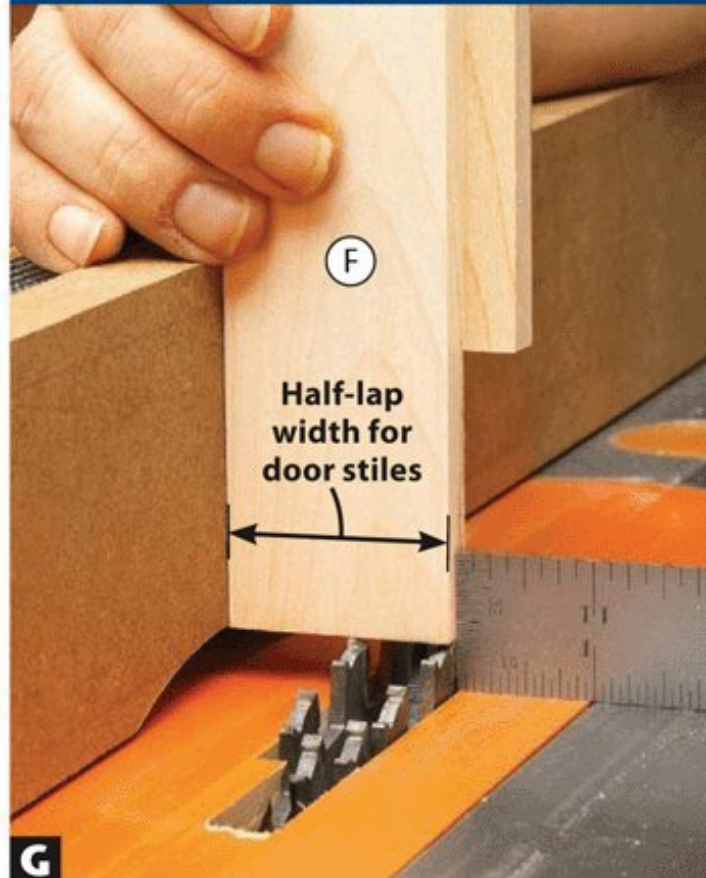

G Shorten the door stile (G) half-lap widths to accommodate the stock removed by rabbets on the rails (F).

ATTACH A FACE-FRAME RAIL

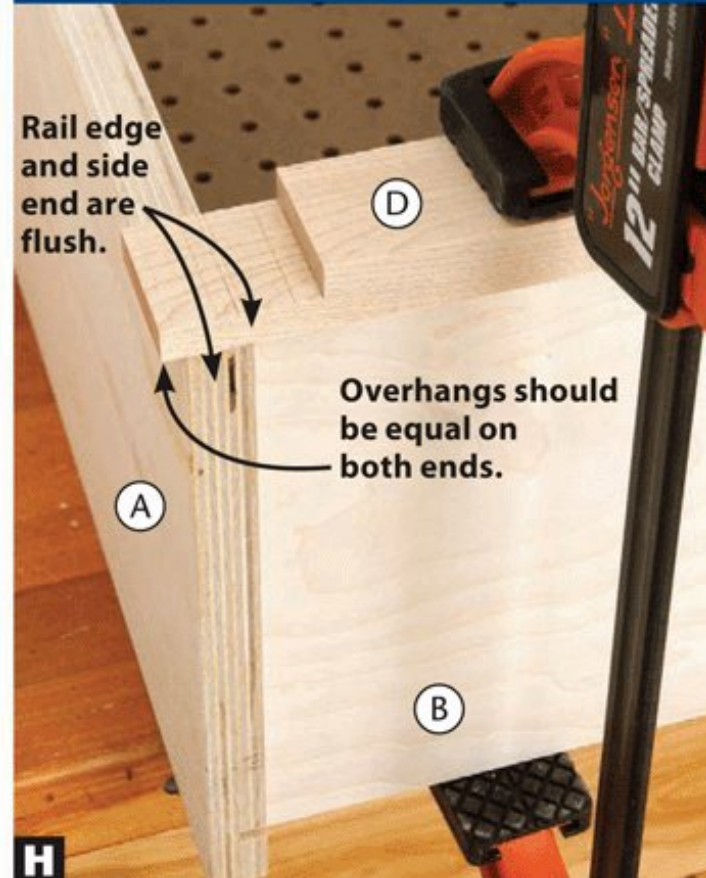

H Overhang the ends of the face-frame rails (D) about $\frac{1}{8}$ " beyond the sides (A). Rail edges should be flush with the ends of the sides.

COMPLETE THE FACE FRAME

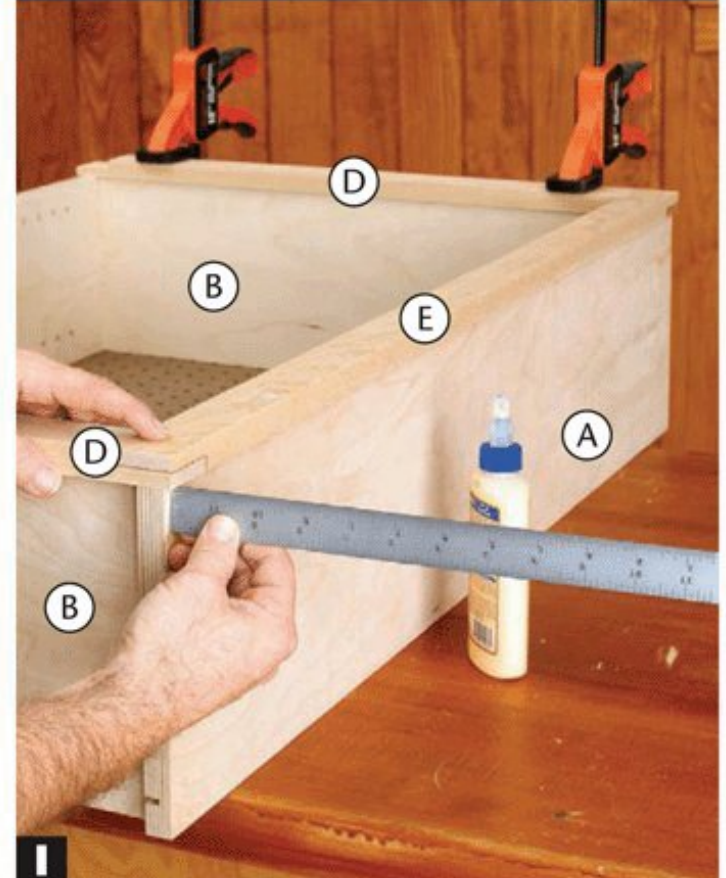

I Install the second face-frame rail (D), overhanging the case sides the same distance as the first rail and tight against the stiles (E).

DRILL HINGE-CUP HOLES



Use a $1\frac{3}{8}$ " Forstner bit to drill a $\frac{3}{8}$ "-deep hole in the door stile (G) to accept the cup on a European-style hinge.

3 Starting with $\frac{1}{4}$ "-thick stock at least $1\frac{1}{2}$ " wide and 52" long, rip two $\frac{3}{8}$ "-wide blanks (H). From each blank, cut one side glass stop and one top/bottom glass stop to fit the door opening. Sand the door frame and stops to 220 grit; and then mark the hinge centerlines on one door stile (G).

4 Using a $1\frac{3}{8}$ " Forstner bit [Photo J], center $\frac{3}{8}$ "-deep hinge-cup holes [Drawing 3a]. Position the door on the face frame, centering it vertically but edge-over-edge with the face-frame stile (E) where you'll attach the hinge [Photo K]. Transfer the hinge centerlines to the face-frame stile.

5 Place the hinge cups in the door holes, with the cup flange parallel to the door edge. Use the flange holes as guides to drill pilot holes for the mounting screws. Then, center the other half of the hinge on the face-frame stile (E) edge where marked, and mark and drill pilot holes. Drill mounting holes for the 3" wire pull [Drawing 3].

Make the shelf and cleats

1 Cut the shelf (I) and shelf trim (J) to size. (Make more shelves, if you like.) Glue and clamp the edging to the shelf. Round over the top and bottom edges of the trim, then finish-sand to 220 grit.

2 Cut the bottom support (K) to size. Then drill $\frac{7}{64}$ " pilot holes and screw it to the back (C) [Drawing 2], guided by the holes in the perforated hardboard.

3 Cut the hanging cleats (L) to size, and bevel one edge on both [Drawing 2a]. Then, screw one cleat to the back

MARK HINGE LOCATIONS

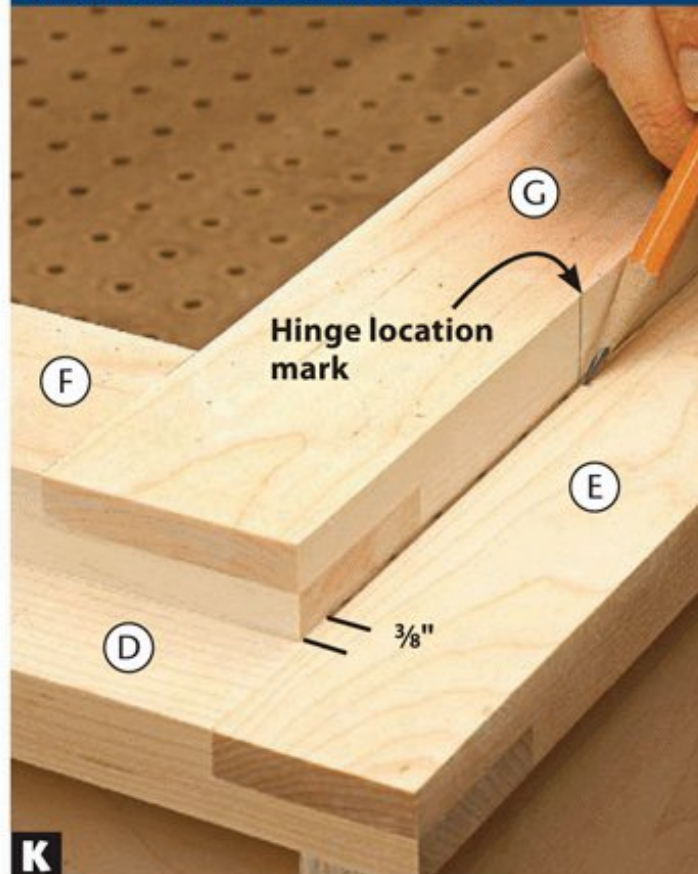

Transfer the hinge centerlines from the door stile (G) to the face-frame stile (E). The door height overlaps the face-frame rails (D) $\frac{3}{8}$ ".

(C), with the square edge up and against the top (B).

4 Cut three bit holders (M) to size, ripping a 15° bevel along one edge of each part. Customize them to suit your needs using the tips in "Space-saving storage strategies" on the next page.

Let's wrap up this case

1 Inspect all the parts and finish-sand where needed. Apply stain, if desired,

3 DOOR

(Viewed from back)

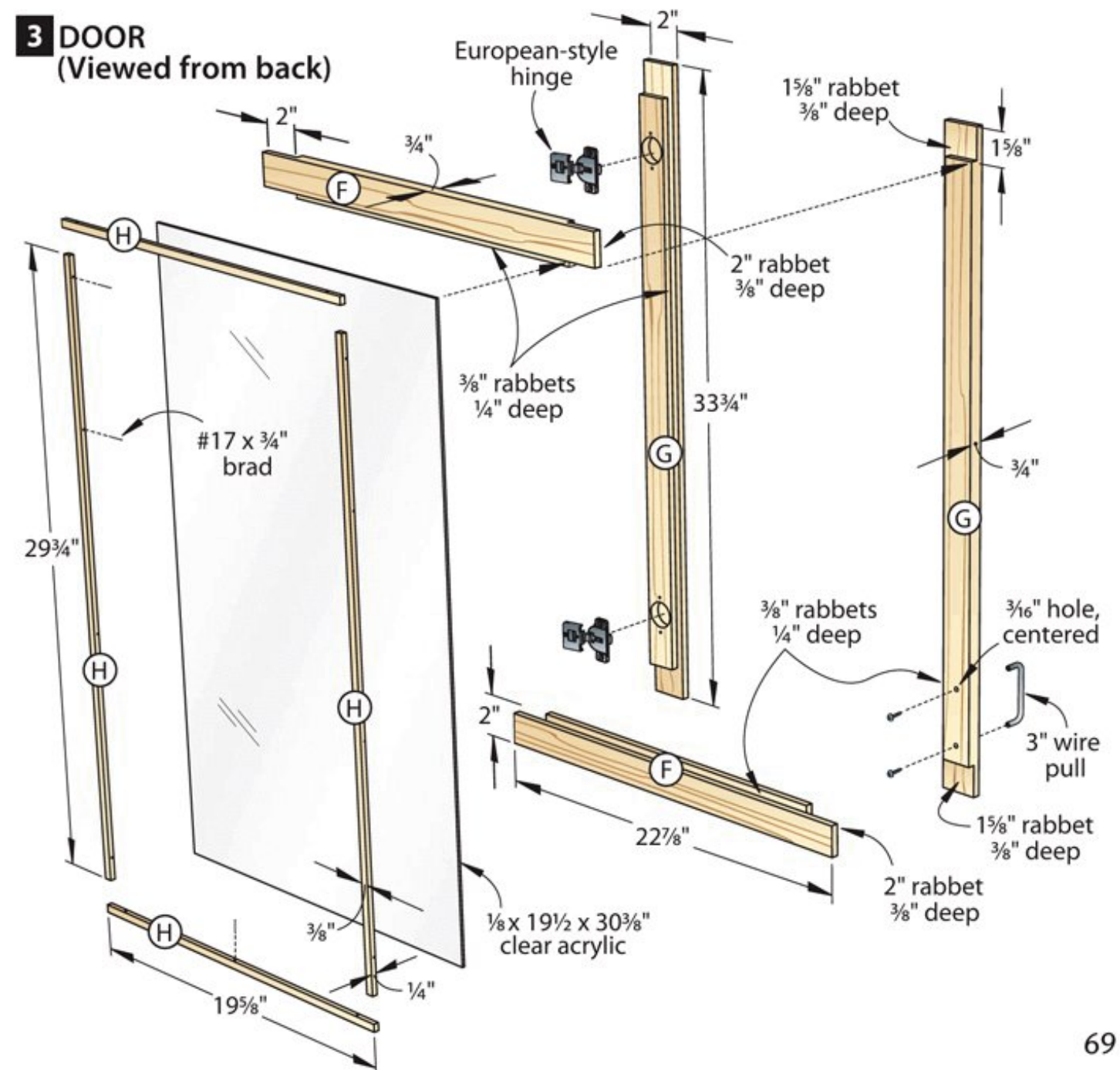

and a clear finish. (We applied two coats of satin polyurethane.)

2 After the finish cures, insert the acrylic in the door frame. Drill pilot holes in the four glass stops and attach them using #17x $\frac{3}{4}$ " brads.

3 Install the wire pull and hinges. Drill pilot holes in the holders (M), and screw them to the back (C) where desired, using holes in the perforated hardboard. Insert shelf supports in the case sides (A), and add the shelf.

4 At the location where you'll mount the case, drill and mount a hanging cleat (L) with the wide face out and beveled edge up. Hang the case on the cleat, round up your drill and router bits, and show them their new home.

3a HINGE DETAIL

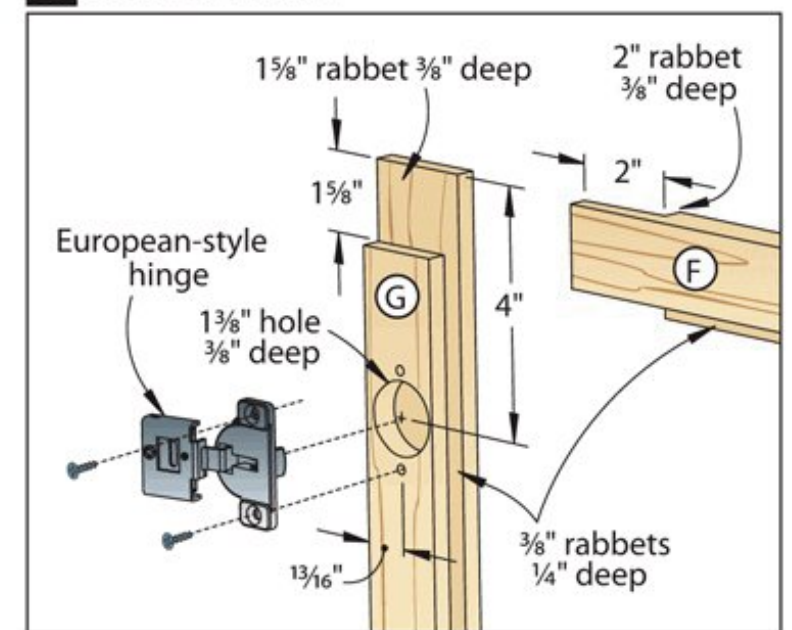

Try these space-saving storage strategies for bits and accessories

Router bits. Space most bits with 1/2"-diameter shanks 1 3/4" apart (on center). Straight and dovetail bits can be spaced as tight as 7/8" apart, but allow up to 4" between holes for panel-raising bits. Space 1/4"-shank bits from 3/4" to 1 1/2" apart. If you're unsure whether you'll

collect more 1/4"- or 1/2"-shank bits, space the 1/4" holes 1 3/4" apart. That way, you can later drill out the 1/4" holes for 1/2"-shank bits.

Forstner bits. Divide your bit set in half and stagger the bit positions along two rows using **Photos L, M, and N** as guides.

Drill accessories. To store countersinks, self-centering bits, plug cutters, screw- or nut-driving bits, and other accessories, space one group of holes 1" apart (on center) on your bit holder. Then drill another group of holes spaced 2" apart for larger-diameter items.



L Mark one end of a Forstner bit holder (M) 1/2" from the top face for the bit hole depth. Hold a scrap against the bevel and position your largest Forstner bit (2 1/8" in our set) with the shank bottom on the line on the end of the bit holder and the top clear of the scrap. The bit shank center indicates where to mark a line for the back row of holes.

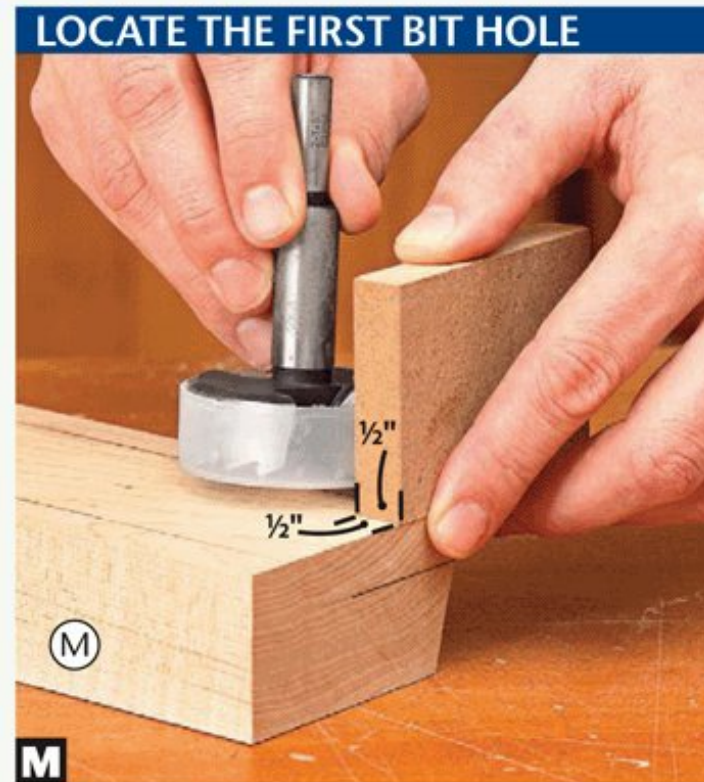

M Inset the cutting edge of the bit from the end of the holder using 1/2" scrap. At the bit spur, mark a centerline for the first hole on the back row. To space bits 1/2" apart, mark the next centerline 2 5/8" from the first one (a 2 1/8" bit). For a bit set graduated in 1/8" increments, decrease the spacing by 1/8" between marks (2 5/8", 2 1/2", 2 3/8", 2 1/4", 2 1/8"...) as needed.



N To lay out the front row of Forstner bits, position the back row of bits with their spurs on each centerline marked in the previous step. Parallel to the center of the spaces between the bits, mark centerlines on the front row line. At each centerline, on both rows, drill a 1/2"-deep hole the shank diameter of the bit to go there.

Cutting Diagram

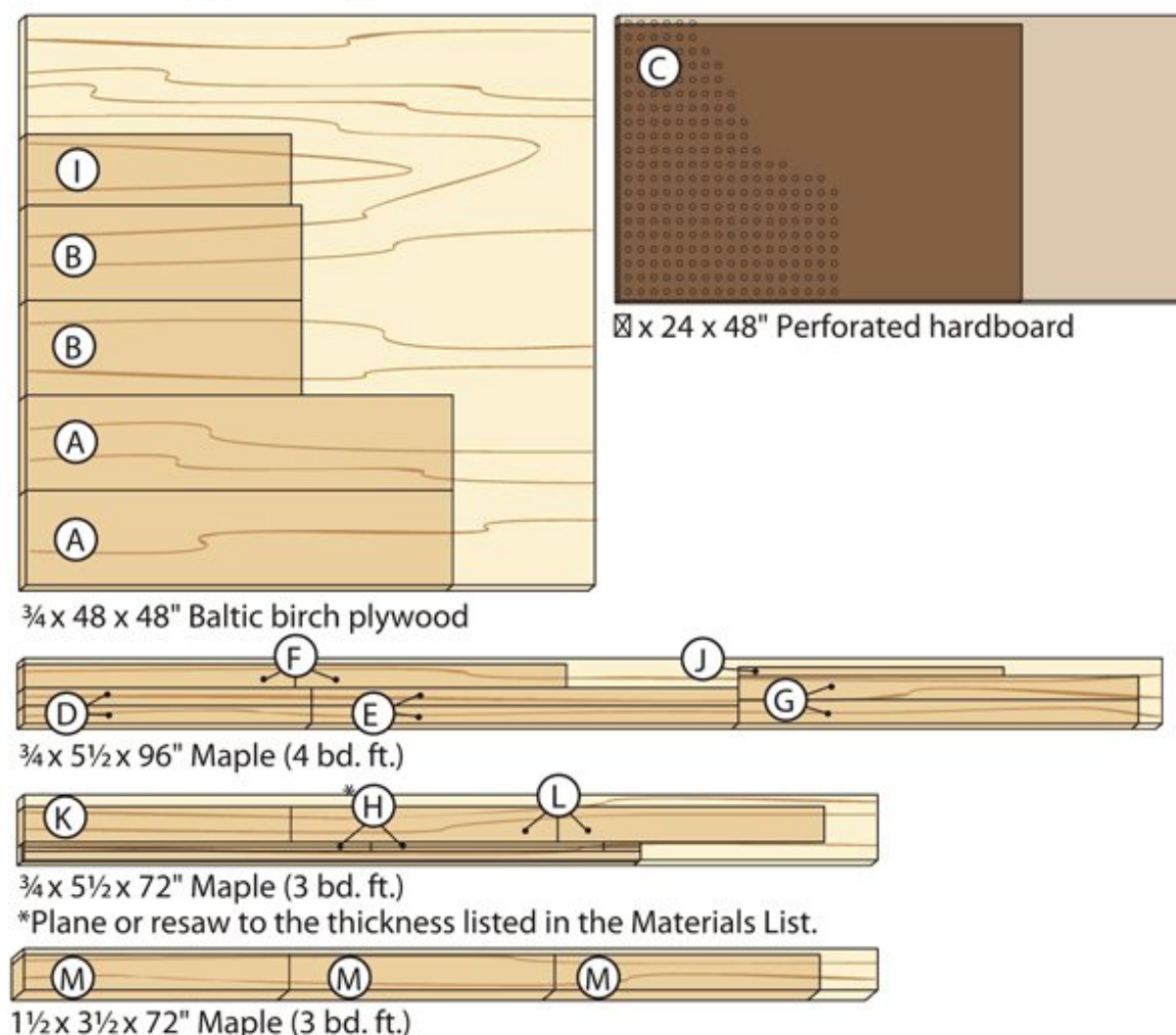

Materials List

Part	FINISHED SIZE			Matl.	Qty.
	T	W	L		
A sides	3/4"	8"	36"	BP	2
B top/bottom	3/4"	8"	23 1/4"	BP	2
C back	3/16"	23 1/4"	34"	PHB	1
D face-frame rails	3/4"	1 1/2"	24 1/4"	M	2
E face-frame stiles	3/4"	1 1/2"	36"	M	2
F door rails	3/4"	2"	22 7/8"	M	2
G door stiles	3/4"	2"	33 3/4"	M	2
H* glass stop blanks	1/4"	3/8"	52"	M	2
I shelf	3/4"	6"	22 3/8"	BP	1†
J shelf trim	3/4"	3/4"	22 3/8"	M	1†
K bottom support	3/4"	3"	22 1/2"	M	1
L hanging cleats	3/4"	3"	22 1/2"	M	2
M bit holders	1 1/2"	3"	22 3/8"	M	3

* Parts initially cut oversize. See the instructions.

† One shelf is shown; more may be added as desired.

Materials key: BP—birch plywood, M—maple, PHB—perforated hardboard.

Supplies: #8x3/4", #8x3" flathead wood screws, shelf pins, European-style hinges (2), #17x3/4" brads, 3" wire pull, 1/8 x 19 1/2 x 30 3/8" clear acrylic.

Blade and bits: Stack dado set, 1 3/8" Forstner bit, 1/4" brad-point bit.

Written by **Bob Wilson** with **Jeff Mertz**

Project design: **Kevin Boyle**

Illustrations: **Roxanne LeMoine; Lorna Johnson**



ToolOrbit

Your **Doorway**
to **Quality**
Woodworking
Tools

Extensive range of woodworking tools at unbeatable prices!



www.ToolOrbit.com 888-722-8299

Do Your Tools Cut It?

Your Long-Term Solution for Carving,
Shaping, Cutting & Sanding.

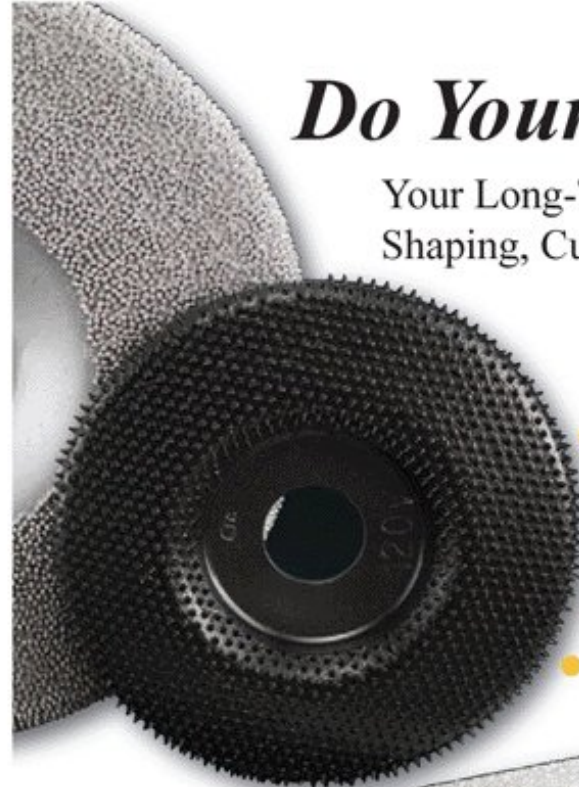

- CUSTOM WOODWORKING
- FURNITURE & RAILINGS
- DIY PROJECTS
- CARVINGS LARGE OR SMALL



Shop Kutzall Direct
www.KutzallDirect.com



Reduce Your Work by 80% or More!
Easy to control, remarkable durability,
and first-class performance.
Let the tools do the work while you take
all the credit.....in far less time.

info@kutzalldirect.com
Phone: (810) 765-1000



PINNACLE
PROFESSIONAL QUALITY TOOLS

Pinnacle is defined by Webster's as *the highest point of development or achievement*. The latest offering of power tool accessories that bears the Pinnacle® name has certainly lived up to this definition. Every detail of these Pinnacle® tools was engineered with one thing in mind: to provide woodworkers with tools that empower them. Pinnacle® tools are available exclusively at Woodcraft.

Made In The USA



Pinnacle®
Saw Gauge
149019



Tired of getting burn marks from your table saw? Woodcraft's Pinnacle® Saw Gauge has been designed to easily give you the precision you need.

- No knobs, no tools, no recalibration
- Automatically adjusts to most miter slots, $\frac{5}{8}$ " - $\frac{7}{8}$ "
- Fitted MDF case for safe storage

PROFESSIONAL QUALITY TOOLS™

Available Exclusively At Woodcraft!

For A Free Catalog Or To Find Your Local Woodcraft Store,
Visit woodcraft.com Or Call 800-225-1153. 10WI07Q

NOVA FORGES A PATH TO A GREENER FUTURE

The DVR motor delivers incredible energy efficiency,
up to 80% power savings over conventional motors



Saving you money, Saving the planet.

The ONLY lathe featuring the Green DVR motor is the NOVA DVR XP lathe. The world's only INTELLIGENT lathe with ONBOARD COMPUTER delivering ENERGY EFFICIENCY, UNIQUE SAFETY SENSING (instantly shutting down the spindle when it senses a chisel dig in) and programmable features

For more, see our website www.teknaatool.com.

NOVA from Teknaatool International

Smart Tools, Powerful Solutions



Jiggity-Diggity-Dock Dancing Clock

Here's a different kind of wood-working "jig." After you put a smile on the face of this project, it will do the same for that special youngster.

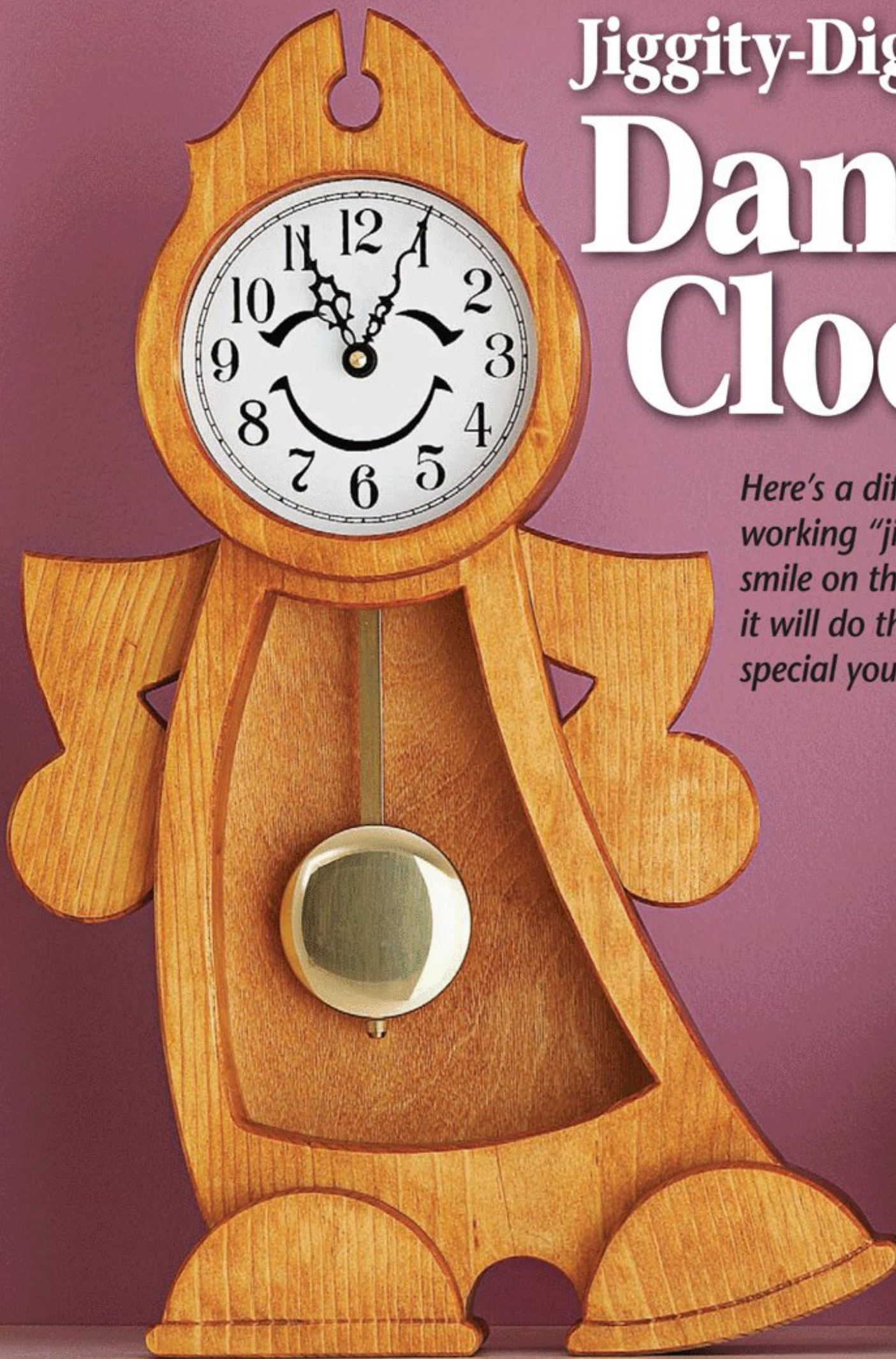

Start with a 6-foot 1×12 on Saturday morning and by Sunday night, this happy character will brighten up a child's room. The clock movement and dial are part of a convenient kit (**Source**, page 74).

Swing into action

1 Prepare three $\frac{3}{4} \times 10\frac{7}{8} \times 17\frac{3}{8}$ " pine blanks and one $\frac{3}{4} \times 6\frac{3}{8} \times 8\frac{1}{8}$ " blank [**Drawing 1**]. You'll also need a 12×12" piece of $\frac{1}{4}$ " plywood.

2 Make four copies of the **Clock Top Pattern** and the **Clock Bottom Pattern** from the *WOOD Patterns*® insert. Tape the patterns together where indicated and set one copy aside for shaping the backs (H, I) later. From one copy, cut out the patterns for the arms (C, D), head (E), and shoes (F, G). Cut and discard the arms from the remaining patterns. Spray-adhere the patterns to the blanks [**Drawing 1**]. At the bandsaw, rough-cut the arm (C) and shoe (F) from the body

back (B) blank. Glue the remaining body back blank to a piece of $\frac{3}{4}$ "-thick stock to make part B 1½" thick [**Drawing 2**].

3 Highlight the lines to cut on each pattern [**Photo A, Drawing 1**]. Drill a $2\frac{1}{64}$ " hole where indicated on the body front (A) and a $\frac{3}{4}$ " hole where indicated at the top of the head (E). Bandsaw to within $\frac{1}{16}$ " of the lines on all the pieces [**Photo B**] and sand them to shape.

4 Remove the pattern from the body back (B) and glue the body front (A)

CUT THE LINE THAT SHINES

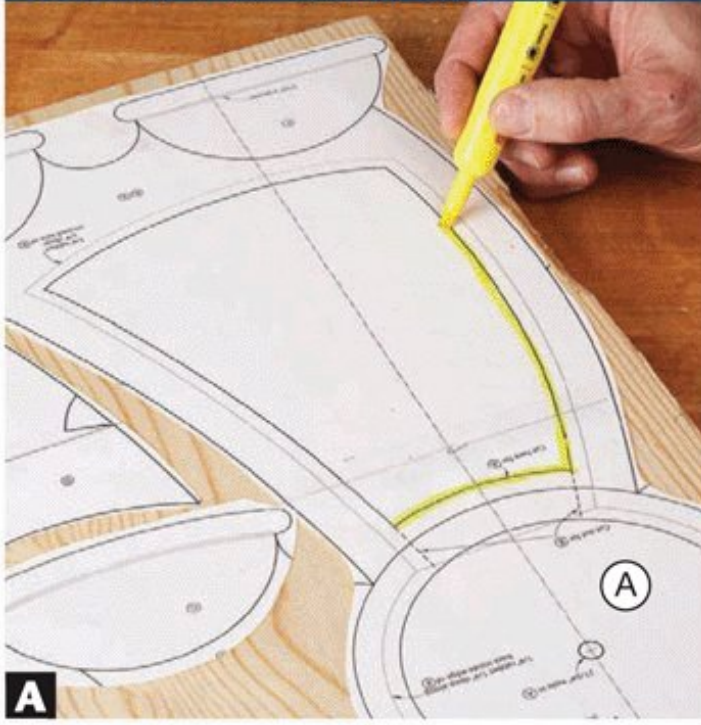

A Make it easy to track the correct cutline by tracing it with a highlighter before going to the bandsaw.

BANDSAW AN INSIDE CUT

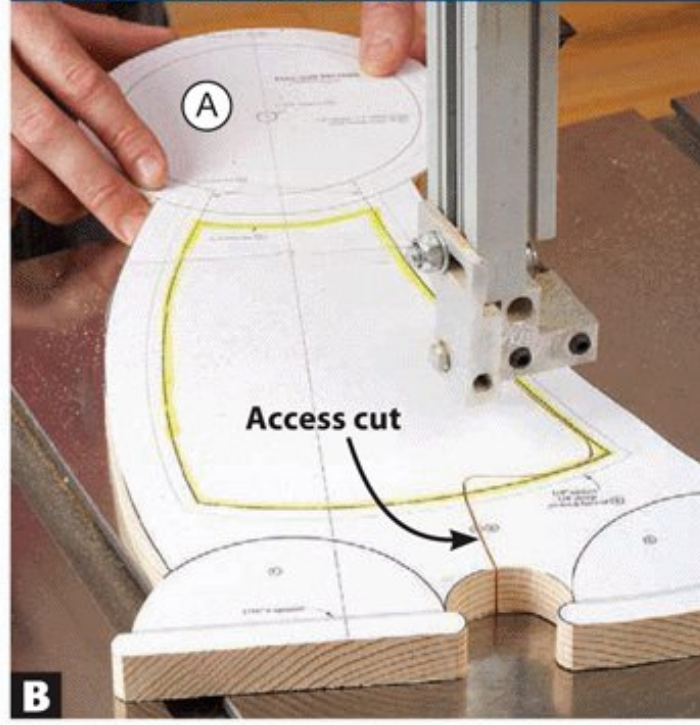

B Access the inside waste areas by making a cut parallel with the grain. Glue the access cuts closed before assembly.

GLUE AND CLAMP THE BODY



C While gluing up the body front (A) and back (B), align the outlines as closely as possible to minimize sanding.

1 PARTS LAYOUT

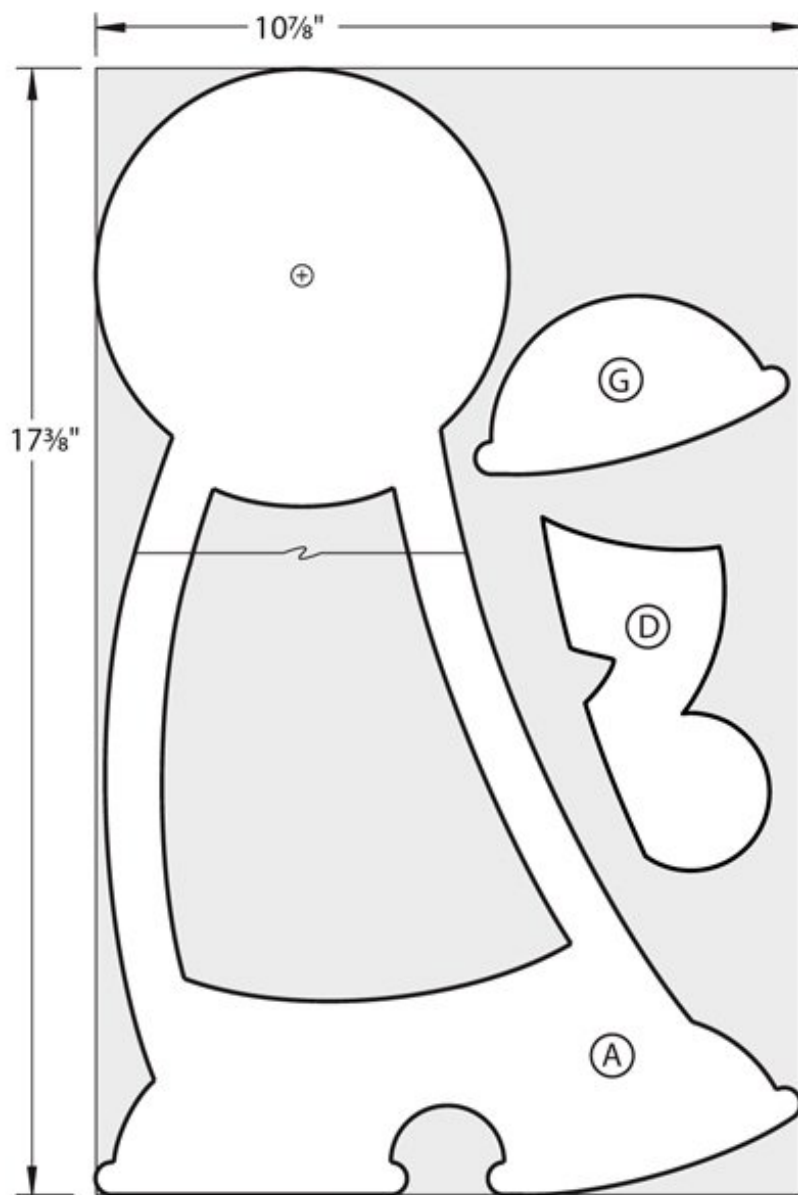

BODY FRONT BLANK

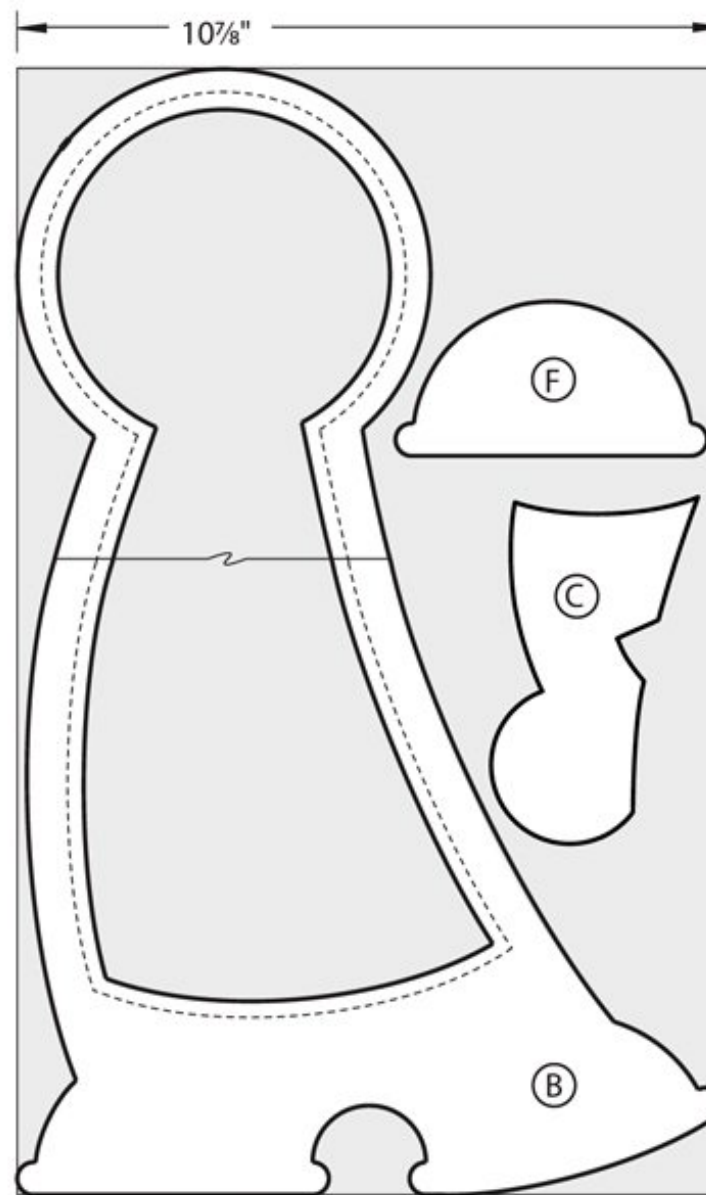

BODY BACK BLANK

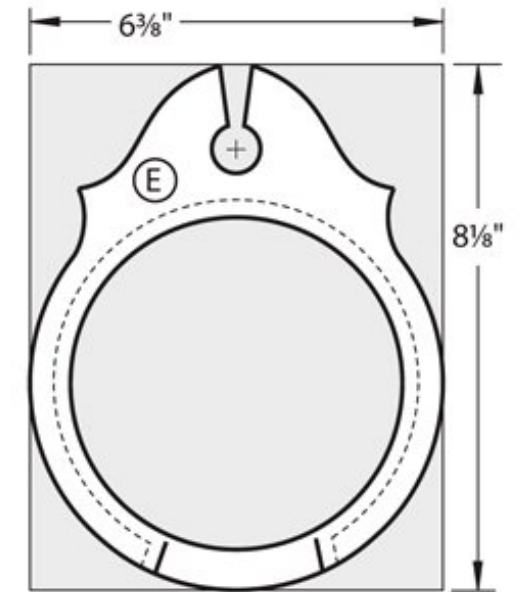

All parts cut from 1x stock. Part B laminated from two layers of 1x stock. See the instructions.

and body back together [Photo C]. Sand the inside and outside edges flush. We used a spindle sander and shop-made sanding blocks [Shop Tip, right], working from 100 grit up to 220 grit. Sand the arms (C, D), head (E), and shoes (F, G) to the pattern lines.

5 Clamp the shoes (F, G) to your bench and use a utility knife to cut a 1/16"-wide groove above the soles [Photo D]. Clean up the grooves with the folded edge of a piece of 150-grit sandpaper. Set

SHOP TIP

Wedges make a point

A wedge-shaped sanding block with three different angles makes it easy to shape corners that a spindle sander can't reach. Rip one from the edge of a wider blank. Cover the wedge with self-adhesive sandpaper or use spray adhesive to glue on regular sandpaper.

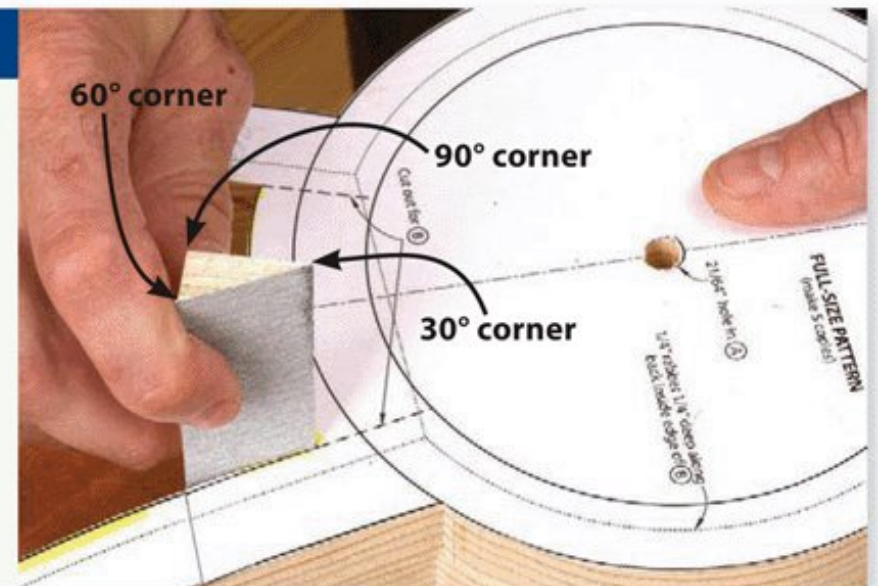

up a chamfer bit in your table-mounted router and rout $\frac{1}{8}$ " chamfers on the body front (A), arms (C, D), head (E), and shoes (F, G) where shown on the patterns. Use a splash of paint thinner to remove the patterns from all pieces. Sand these pieces to 220 grit.

6 Glue the head (E) and shoes (F, G) onto the body front (A) and sand the edges flush. Check the fit of the arms (C, D) against the body backs (B) and sand as needed to get a tight fit. Glue the arms in place [Photo E].

7 Rout a $\frac{1}{4}$ " rabbet $\frac{1}{4}$ " deep around the cavity at the rear of the body (A-G) [Drawing 2]. Retrieve the pattern set aside earlier, spray-adhere it to $\frac{1}{4}$ " plywood, and cut out the backs (H, I), cutting just outside the dashed lines. Sand the edges of the backs to fit in the rabbets. Screw the turnbuttons to the rear of the body.

8 Apply a finish to all parts. (We stained ours with Varathane Pecan No. 218, then brushed on two coats of polyurethane varnish.)

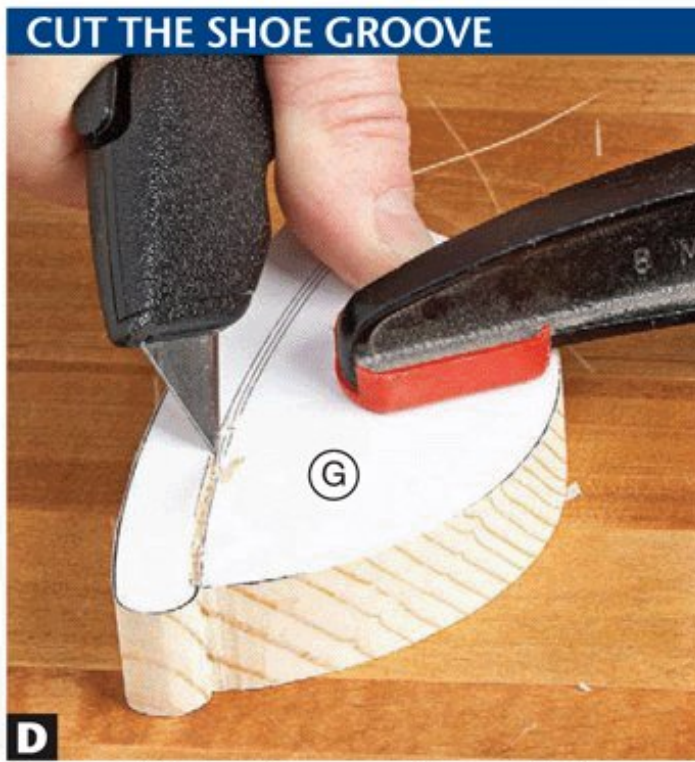

D Carve a $\frac{1}{16}$ "-deep V-groove by carefully cutting along the pattern lines. Deepen the groove with successive cuts if needed.



E Sand "wrist" and "shoulder" to fit. Glue the arms (C, D) to the body (A/B/E/F/G) centered on the thickness of the body. Use glue sparingly to minimize squeeze-out.

9 Glue the clock face to the body (A), aligning the 12 with the hole in the head (E) [Drawing 2]. Install the clock movement and a battery and attach the hands. Trim the pendulum arm to $6\frac{3}{4}$ ", hang it from the clock movement, then

start the pendulum swinging. If it taps against the side of the body, rotate the clock movement slightly. Place the backs (H, I) into the rabbets in the body back (B) and tighten the turnbuttons to hold the backs in place. 🌱

2 EXPLODED VIEW

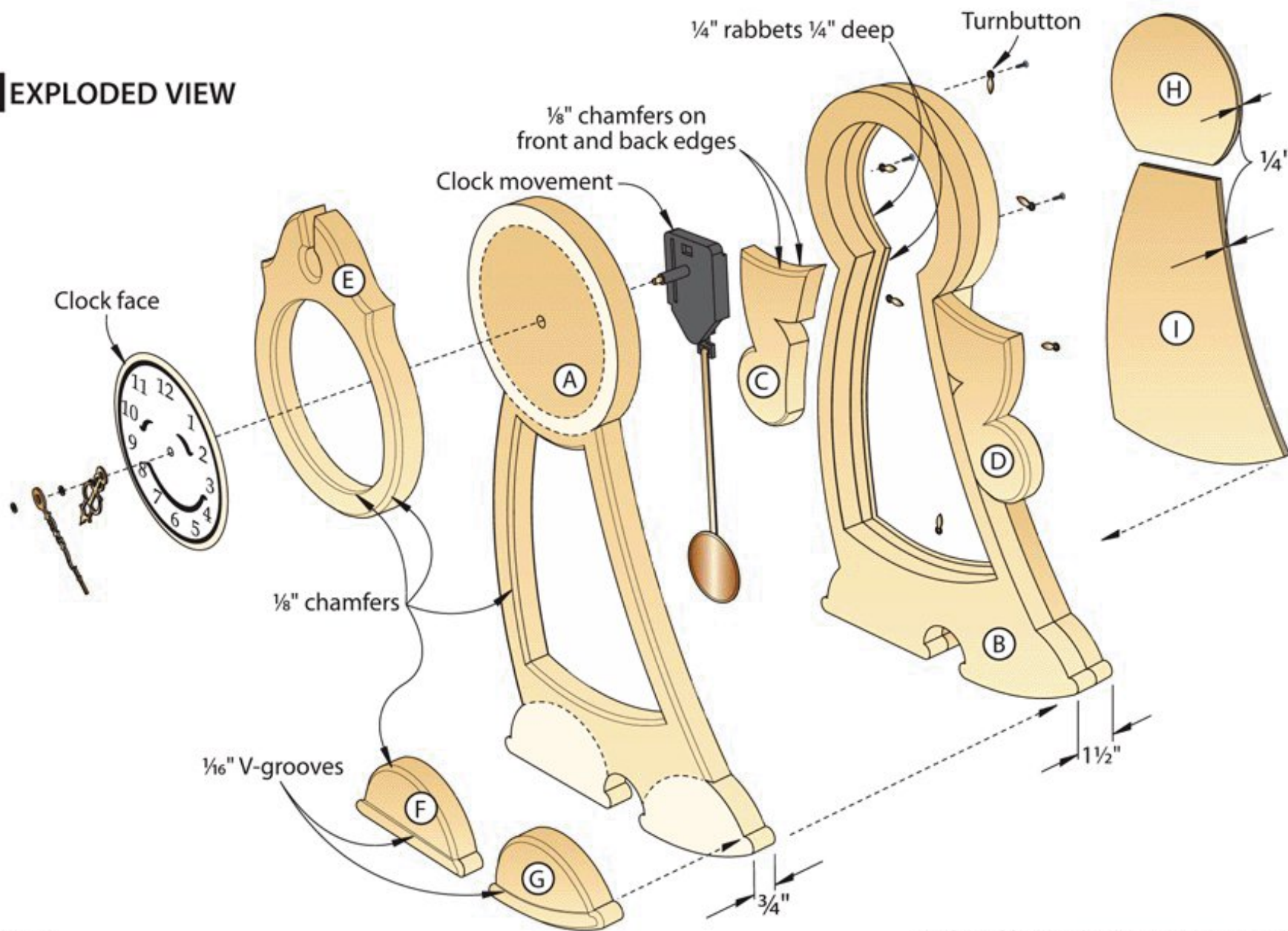

Supplies: Spray adhesive.
Blade and bits: $\frac{1}{8}$ " bandsaw blade; $2\frac{1}{64}$ ", $\frac{3}{4}$ " drill bits; 45° chamfer, $\frac{1}{4}$ " rabbet router bits.

Source

Hardware kit contains: $\frac{5}{8}$ " turnbuttons (8), pendulum clock movement, clock hands, clock face. Kit no. 4500, \$16.95, Meisel Hardware Specialties, 800-441-9870, meiselwoodhobby.com.
Lumber: $\frac{1}{4}$ "x12"x12" plywood, no. 4501, \$3.25, Meisel Hardware Specialties.

Produced by **Craig Ruegsegger** with **Kevin Boyle**
 Project design: **Paul Meisel**
 Illustrations: **Roxanne LeMoine; Lorna Johnson**

Cutting Diagram

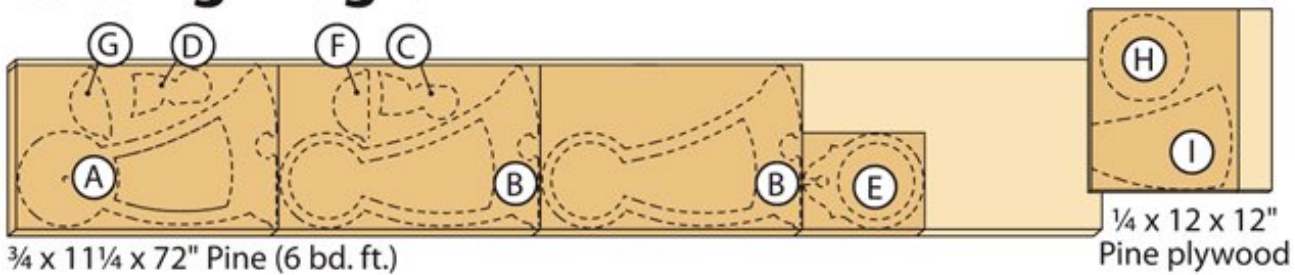

Truly Unique



Time travel at the speed of a 1935 Speedster?

The 1930s brought unprecedented innovation in machine-age technology and materials. Industrial designers from the auto industry translated the principles of aerodynamics and streamlining into everyday objects like radios and toasters. It was also a decade when an unequalled variety of watch cases and movements came into being. In lieu of hands to tell time, one such complication, called a jumping mechanism, utilized numerals on a disc viewed through a window. With its striking resemblance to the dashboard gauges and radio dials of the decade, the jump hour watch was indeed "in tune" with the times!

The Stauer 1930s Dashtronic deftly blends the modern functionality of a 21-jewel automatic movement and 3-ATM water resistance with the

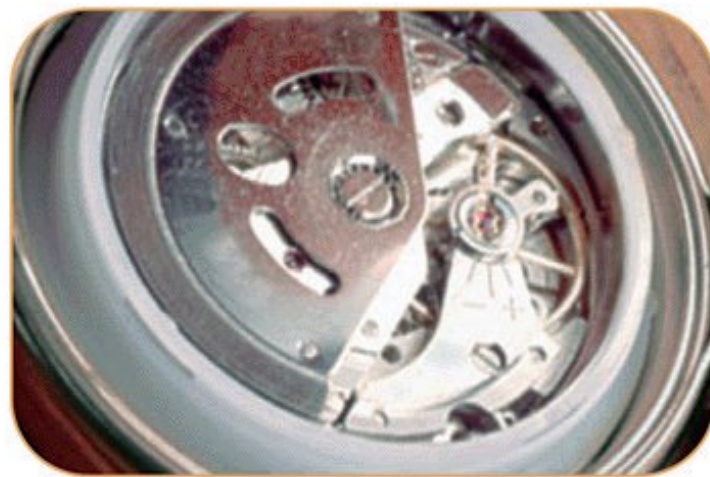

True to Machine Art esthetics, the sleek brushed stainless steel case is clear on the back, allowing a peek at the inner workings.

distinctive, retro look of a jumping display (not an actual jumping complication). The stainless steel 1 1/2" case is complemented with a black alligator-embossed leather band. The band is 9 1/2" long and will fit a 7-8 1/2" wrist.

Try the Stauer 1930s Dashtronic Watch for 30 days and if you are not

receiving compliments, please return the watch for a full refund of the purchase price. If you have an appreciation for classic design with precision accuracy, the 1930s Dashtronic Watch is built for you. This watch is a limited edition, so please act quickly. Our last two limited edition watches are totally sold out!

Not Available in Stores

Stauer 1930s Dashtronic Watch **\$99 +S&H** or
3 easy credit card payments of \$33 +S&H
Call now to take advantage of this limited offer.

1-800-859-1602

Promotional Code DRW481-02
Please mention this code when you call.

Stauer 14101 Southcross Drive W.,
Dept. DRW481-02
Burnsville, Minnesota 55337
www.stauer.com



SHOP TESTED

Cordless Micro- Drivers

These compact but capable tools pack surprising punch, making them the go-to drivers in our shop.

Our tester fills up another pine 2x6 with 1½" drywall screws.

Just as the diminutive David slew the ferocious giant, Goliath, to the surprise of everyone, these pint-size lithium-ion powered tools blew our expectations out of the water with their staggering screw-driving abilities. In fact, since we began using them, the larger 14.4- and 18-volt drill/drivers in the *WOOD*® magazine shop now see primarily drilling duty as we reach for compact 10.8- and 12-volt micro-drivers almost exclusively for driving screws—especially for hinges and small hardware. Their compact size minimizes hand fatigue and provides them better access to tight quarters.

They're lightweights, but only literally

With weights ranging from 1.8 to 2.6 lbs (with battery installed), these cordless tools weigh about half as much as nickel-cadmium powered 14.4-volt drill/drivers, and even less than the bulkier 18-volt drills. They achieve this by using lighter-weight lithium-ion chemistries in their compact battery packs. Although most micro-driver manufacturers claim 12 volts of power compared to 10.8 for others, we saw no distinct advantage that could be traced to rated voltage. (One manufacturer started the trend of claiming 12 volts of power, and for competitive reasons most others followed suit.)

As shown in the chart on the *next page*, all 10 units drove more than 150 1½" drywall screws into pine on a single charge. That's impressive enough, but five drivers topped the 200 mark, led by the Milwaukee 2401-22 at an average of 259. That's likely more than you'll drive in one day, anyway. (By comparison, the 14.4-volt drill/drivers we tested only a few years ago drove from 217 to 522 screws per charge.)

Next, we wondered how these compact units would perform in a pinch at drilling holes. Using new ¾" spade bits, all the tools drilled at least 19 1½"-deep holes in pine on a single charge. The Ryobi HJP002K nearly tripled that with an average of 48 holes per charge. Six models feature dual speed ranges, and we drilled about the same number of holes using both speed ranges. We could, as you'd expect, drill holes faster in the high range.

It's nice to know these micro-drivers drill small holes okay, but most struggle with bits larger than ¾" in diameter and drill slower than larger drills. Driving screws is what these tools do best, effectively making micro-drivers a bit of a luxury item for most home workshops. So if you can buy only one tool for your drilling and driving needs, get a conventional 14.4-volt or larger model.



Bosch PS20-2A, \$125
877-267-2499
boschtools.com



Bosch PS30-2A, \$140
877-267-2499
boschtools.com



Craftsman 11812, \$90
800-383-4814
craftsman.com



Hitachi DB10DL, \$129
800-829-4752
hitachipowertools.com



Makita DF030DW, \$149
800-462-5482
makita.com



Makita DF330DW, \$159
800-462-5482
makita.com



Milwaukee 2401-22, \$129
800-729-3878
milwaukeetool.com



Milwaukee 2410-22, \$149
800-729-3878
milwaukeetool.com



Ridgid R92008, \$130
866-539-1710
ridgid.com



Ryobi HJP002K, \$70
800-525-2579
ryobitools.com

CHOOSE YOUR CHUCK



Drivers with a $\frac{3}{8}$ " three-jaw chuck (left) work with hex- and round-shank bits. Models with a hex chuck (right) accept only bits with $\frac{1}{4}$ " hex shanks.

To really separate the tools from the toys, we tested each driver's torque by driving 2" lag screws of different diameters into predrilled pine. As shown in the chart at right, only the Makita DF030DW could fully seat a $\frac{3}{8}$ "-diameter lag. The Ridgid R92008 and Ryobi shut down suddenly while driving $\frac{5}{16}$ " lags. Jason Swanson, spokesman for both brands, said the electronic "brains" inside the battery packs stop these models to protect the batteries under extreme conditions.

More to consider before buying

■ **Charge time.** Each driver comes with two batteries and a charger. The Craftsman 11812 and both Bosch models charged fastest, needing only 30 minutes. All others required from 35 to 60 minutes. Still, given the run time per charge shown by most of the drivers, you'll likely not exhaust a battery before the second one is recharged.

■ **Chucks.** Six models feature $\frac{3}{8}$ " three-jaw chucks, while the others have quick-connect $\frac{1}{4}$ " hex chucks, shown above. Neither style proved a deal-breaker, unless you plan to drill much with the tool; only the three-jaw chucks accept round-shank bits.

■ **Clutches.** All the tools sport clutches with at least 10 settings—most had 18 or more—and we found all the clutches helpful to prevent strip-

FIVE DRIVERS TOP 200 SCREWS

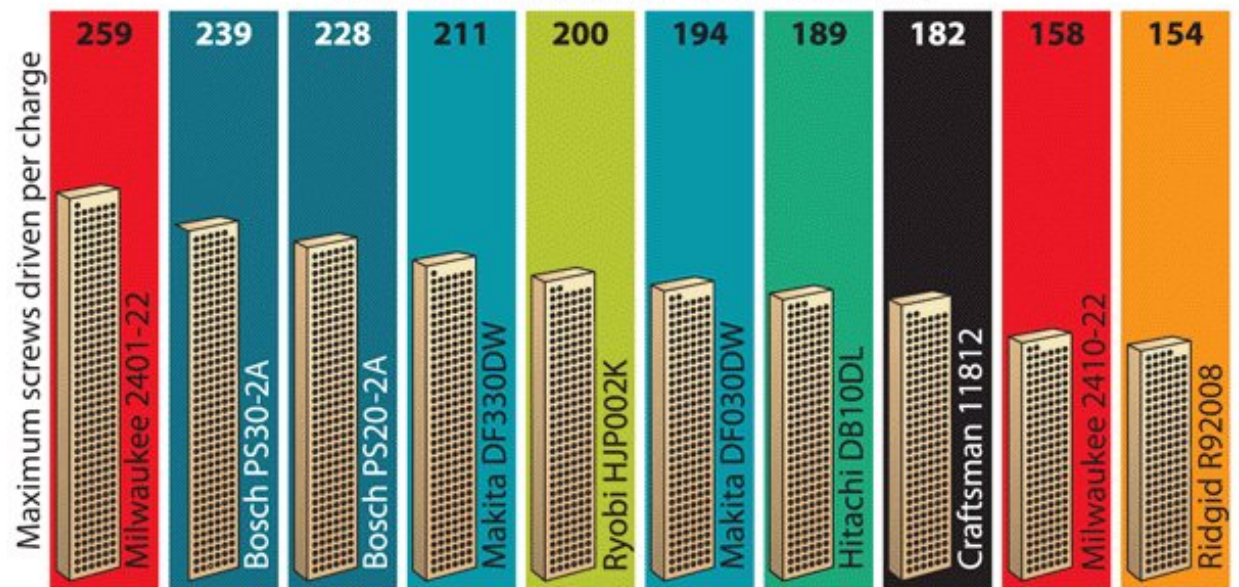

Note: All tests done in 2x6 pine, two tests per battery, total of four per tool.

ONLY ONE DRIVER SEATED A $\frac{3}{8}$ x 2" LAG SCREW

Maximum size lag screw driven, fully seated or partially.

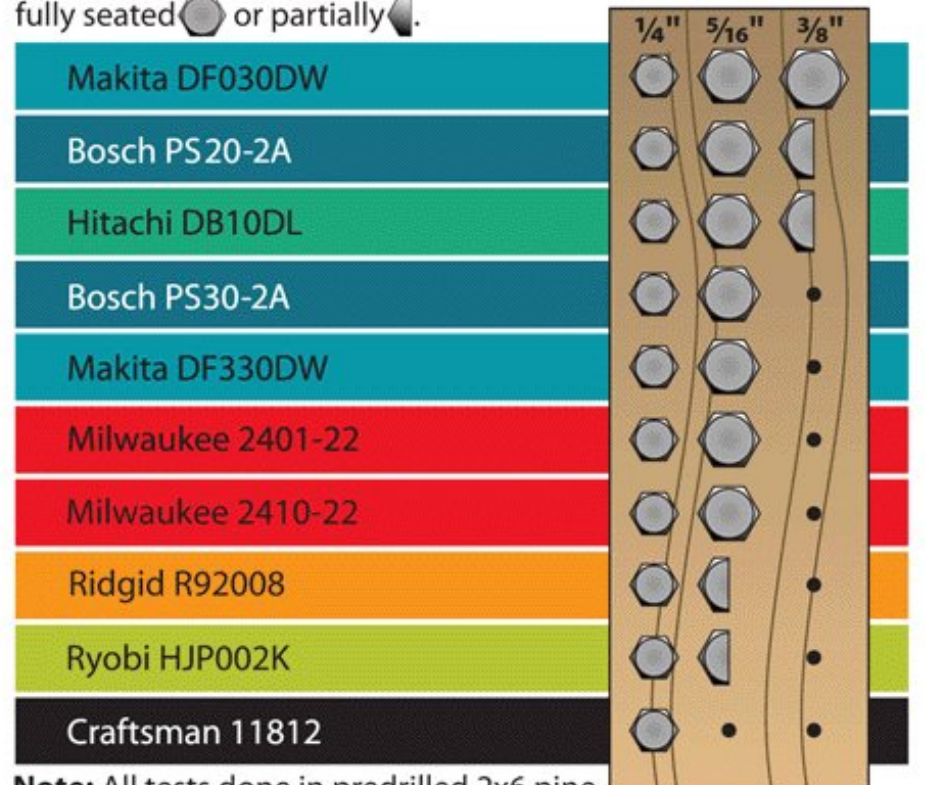

Note: All tests done in predrilled 2x6 pine, two tests per battery, total of four per tool.

ping out or shearing off heads of brittle drywall screws, as well as tiny brass hinge screws. However, clutches on the Bosch PS30-2A, Hitachi DB10DL, Milwaukee 2410-22, Ridgid, and Ryobi proved more difficult to grip and turn.

■ **Grip comfort and balance.** Most of the drivers felt comfortable and nicely balanced. Those with three-jaw chucks proved slightly more front heavy; Ridgid's beefy chuck made that driver very out of balance and awkward to hold. Battery packs on some models feature small stems, resulting in slimmer grips, as shown at *right*. The triangular-shaped packs on the others slide into the handles, requiring thicker grips that could be uncomfortable for small hands.

■ **Task lights.** All but the Ryobi come with a trigger-activated LED light to illuminate your work area, but some work better than others. Hitachi's dual lights work best because they're mounted within the clutch assembly rather than

below it, as with the rest. This low position on the others casts light slightly below the point of contact when working with bits shorter than 4".

Our recommendation

Any of these micro-drivers would likely be a welcome addition to any shop. But for us, three models drove to the head of the class to share our Top Tool award: Bosch PS20-2A, Makita DF030DW, and Milwaukee 2401-22. The Makita displayed the best power, and the Milwaukee demonstrated the longest run time per battery charge. The Bosch was second-best in power and third-best in run time. All are well-balanced, comfortable to grip, and feature easy-to-use clutches and hex chucks. We suggest you choose the one that feels best in your hand. 🌿

Written by **Bob Hunter** with **Doug Ley**
Illustrations: **Tim Cahill**



FIND A GRIP YOU LIKE

Eight of the 10 drivers feature thicker grips, like the Bosch PS20-2A (left). The Hitachi (right) and Ryobi have slim grips.

GET POWERFUL PUNCH FROM A PINT-SIZE DRIVER																					
BRAND	MODEL (1)	BATTERY PACKS			DRILL			PERFORMANCE RATINGS (3)													
		RATED VOLTAGE	AMP-HOURS	NUMBER INCLUDED	W/MAX. MOTOR SPEED, RPM	CHUCK TYPE (2)	NUMBER OF CLUTCH SETTINGS	PRIMARY		SECONDARY					NUMBER OF DRIVER BITS INCLUDED	BUILT-IN TASK LIGHT? YES, NO	STORAGE CASE (5)	WEIGHT (WITH BATTERY), LBS	COUNTRY OF ASSEMBLY (6)	WARRANTY, YEARS (7)	SELLING PRICE (8)
								POWER (TORQUE)	RUN TIME PER CHARGE (4)	BATTERY CHARGE TIME	OVERALL FEEL AND BALANCE	EASE OF USING FORWARD/REVERSE	EASE OF USING CHUCK	EASE OF USING CLUTCH							
BOSCH	PS20-2A	12	1.3	2	500	H	10	A-	B+	a	a	a	a-	a	2	Y	C	1.8	M	1*	\$125
	PS30-2A	12	1.3	2	400/1,100	J	20	B+	A-	a	b	a-	a	b	2	Y	C	2.3	M	1*	\$140
CRAFTSMAN	11812	12	1.3	2	400/1,300	J	18	C	B	a	b	b	a-	a-	1	Y	C	2.2	C	1	\$90
HITACHI	DB10DL	10.8	1.5	2	400	H	21	A-	B+	b	a	a	a-	b-	7	Y	P	1.8	C	10†	\$129
MAKITA	DF030DW	10.8	1.3	2	350/1,300	H	18	A	B	b	a	a-	a	a	1	Y	P	1.9	C	3^	\$149
	DF330DW	10.8	1.3	2	350/1,300	J	18	B+	B+	b	b	a-	a	a	1	Y	P	2.2	C	3^	\$159
MILWAUKEE	2401-22	12	1.3	2	500	H	15	B+	A	a-	a	a	a	a	2	Y	C	2.0	C	5†	\$129
	2410-22	12	1.4	2	400/1,500	J	21	B+	B-	b+	b	a	a	b	0	Y	P	2.5	C	5†	\$149
RIDGID	R92008*	12	1.5	2	320/1,300	J	18	B-	B-	b	c-	b	b	b	0	Y	C	2.6	C	3#	\$130
RYOBI	HJP002K	12	1.3	2	600	J	24	B-	A-	c	b+	b	c	c	1	N	C	2.0	C	2	\$70

1. (*) Comes with an LED flashlight

2. (H) 1/4" hex chuck
(J) 3/8" three-jaw chuck

3. A Excellent
B Good
C Fair

4. Measured from an average of driving screws and drilling holes.

5. (C) Canvas
(P) Plastic

6. (C) China
(M) Malaysia

7. (*) 3 years for drill and 2 years for batteries optional
(†) Two years for batteries
(^) One year for charger and batteries
(#) Lifetime service agreement optional

8. Prices current at time of article production and do not include shipping, where applicable.

FREE Product Information from Advertisers in This Issue

Looking for FREE product information? Fill out the coupon in this section to receive FREE product info and catalogs. Or, for quicker service and instant access to information, visit us online at www.woodworkerscenter.com

Adhesives & Finishes

TITEBOND® III ULTIMATE WOOD GLUE Superior bond strength, waterproof, longer open-assembly time. The Best Wood Glue Ever! **Circle No. 24.**

GORILLA WOOD GLUE High strength, shorter clamp time, and no dyes for a natural finish. Try it today on your next building project. **Circle No. 50.**

Bits, Blades, Cutting Tools

CMT ORANGE TOOLS Top quality industrial saw blades and router bits at affordable pricing. **Circle No. 180.**

FINAL CUT SAW BLADE Only blade that cuts and sands at the same time. **Circle No. 194.**

FORREST MFG. CO., INC. Top quality blades and dados for an ultra smooth finish. **Circle No. 206.**

FREUD SAW BLADES This 48-page catalog illustrates the features and benefits for all Freud saw blades. **Circle No. 219.**

FREUD ROUTER BITS All Freud router bits are represented in this 84-page catalog, including more than 130 new bits and sets. **Circle No. 232.**

KUTZALL TOOLS Abrasive carbide coated tools for non-metals. Everything for carving, shaping, cutting and sanding. **Circle No. 237.**

Books, Plans and Videos

AMERICAN FURNITURE DESIGN CO. 150 of America's best furniture plans, comprehensive instruction guide. Catalog. **Circle No. 336.**

U-BILD WOODWORKING PLANS Since 1948! Hundreds of full-size plans, downloadable plans, low prices. **Circle No. 435.**

General Woodworking Catalogs

GRIZZLY INDUSTRIAL, INC. 12,000 woodworking and metalworking machines, tools and accessories — unbeatable prices! **Circle No. 583.**

WOODCRAFT SUPPLY CORP. Over 15,000 top quality woodworking tools, supplies, and accessories. **Circle No. 700.**

Hand Tools, Jigs & Clamps

AFFINITY TOOL WORKS Manufacturer of quality hand tools and products for cabinetmaking, carpentry, woodworking. **Circle No. 734.**

KREG TOOL CO. Your one stop shop for everything Pocket-Screw related. **Circle No. 802.**

STANLEY SWEETHEART HAND PLANES New Sweetheart premium hand planes by Stanley. **Circle No. 829.**

Hardwood & Lumber

M.L. CONDON COMPANY Single, convenient source for lumber, plywood, mouldings, custom millwork, more. **Circle No. 844.**

LOGOSOL, INC. Portable sawmills, precision woodworking machinery. **Circle No. 845.**

STEVE H. WALL LUMBER CO. Quality hardwoods, plywood, exotic lumber. Ship UPS/motor freight, wholesale prices. **Circle No. 856.**

WOODWORKERS SOURCE Hardwoods from around the world. **Circle No. 869.**

Income Opportunities & Education

FURNITURE MEDIC Offering franchise licenses to qualified individuals to perform mobile, on-site furniture repair & restoration services. **Circle No. 895.**

WOODCRAFT RETAIL FRANCHISE Own a Woodcraft Store — franchises offered for stores across the country. **Circle No. 924.**

Kits

DETAILED PLAY SYSTEMS Wooden swingsets and playground equipment for the backyard. Free catalog. **Circle No. 958.**

STEEBAR For over 20 years supplying clock kits, pen making kits, and woodworking plans. **Circle No. 1002.**

WOODEN-GEAR-CLOCKS.COM Create a wooden gear clock—kits and plans available. **Circle No. 1008.**

Miscellaneous

APOLLO SPRAYERS TURBINE SYSTEMS Quality control, engineering and durability. **Circle No. 1061.**

AZTEC STEEL CORP. Quality pre-engineered arch-style steel buildings at the lowest cost anywhere. **Circle No. 1064.**

CENTRAL BOILER Classic Wood Furnaces — clean, safe, efficient heat for your home. **Circle No. 1105.**

RADIANT FLOOR COMPANY Radiant Heating Systems—design, manufacture and sale for the DIY. **Circle No. 1301.**

ROCKAUTO.COM Check out www.RockAuto.com for all the parts your car or truck will ever need. **Circle No. 1310.**

Power Tools

COOK'S SAW MFG., L.L.C. Portable sawmills, Edgers, Sharpeners, Band Blades... Free catalog. Video available. **Circle No. 1480.**

FREUD POWER TOOLS 16-page catalog illustrates dependable power tools with traditional Freud quality. **Circle No. 1532.**

GRANBERG INTERNATIONAL Alaskan Saw Mill, chain saw accessories. Made in USA. **Circle No. 1558.**

RADARCARVE Manufacturer of specialized wood carving duplicators. **Circle No. 1673.**

STANLEY-BOSTITCH FINISH NAILERS & STAPLERS The preferred brand among professionals when it comes to finish nailers and staplers. **Circle No. 1768.**

TOOLMART INC. Woodworking tools and accessories by top brands: Delta, DeWalt, Porter Cable, Jet, Powermatic. **Circle No. 1770.**

WOODMASTER TOOLS Multi-duty planers that mold, sand & saw. **Circle No. 1820.**

Project Parts & Materials

OSBORNE WOOD PRODUCTS, INC. A free catalog of table legs, corbels, and island legs. **Circle No. 1849.**

OSBORNE WOOD PRODUCTS, INC. WOOD CORBELS offer classic corbels in a broad range of styles. **Circle No. 1851.**

Shop Accessories

AMERICAN FABRIC FILTER CO., INC. Manufacturers of custom-made filter bags for the wood industry. **Circle No. 1868.**

CARTER PRODUCTS COMPANY, INC. Bandsaw Guide kits, tires, stabilizer guides, and many other products. **Circle No. 1883.**

LIGNOMAT USA, LTD. Affordable, reliable, pin and pinless moisture meters for wood. Free catalog. **Circle No. 2013.**

PENN STATE INDUSTRIES Award-winning dust collection. Collectors, Cyclones, Ductwork and more. **Circle No. 2045.**

Woodturning Supplies

BEREA HARDWOODS Quality pen kits and other turning kits. **Circle No. 2127.**

HUT PRODUCTS Woods, acrylics and supplies for pen and game call turning. **Circle No. 2133.**

NOVA. SMART TOOLS, POWERFUL SOLUTIONS NOVA lathes, chucks and accessories consistently lead the way in innovative design with their unique mix of powerful features and great value. **Circle No. 2134.**

PACKARD WOODWORKS Free Catalog for WOODTURNERS! — Quality Lathes, Tools and Supplies. **Circle No. 2143.**

PENN STATE INDUSTRIES Leading supplier of Turning Products. Pen kits, project, finishes and more. **Circle No. 2151.**

FREE Product Information

DEPT. WOJJ10

CIRCLE THE NUMBERS BELOW CORRESPONDING TO ITEMS IN THIS ISSUE.

24	237	844	1008	1558	1883	4000
50	336	845	1061	1673	2013	
180	435	856	1064	1768	2045	
194	583	869	1105	1770	2127	
205	700	895	1301	1820	2133	
206	734	924	1310	1849	2134	
219	802	958	1480	1851	2143	
232	829	1002	1532	1868	2151	

Discover how rewarding woodworking can be! Get one full year of WOOD® for just \$28.00 (7 issues). Simply circle No. 4000. You will be billed later.

NAME _____
 ADDRESS _____
 CITY _____ STATE _____ ZIP _____
 E-MAIL ADDRESS _____
 PHONE (OPTIONAL) _____

TO ENSURE PROMPT HANDLING OF YOUR ORDER, PLEASE:

- Circle Your Choice(s) in the box above
- Send card to
WOOD® Magazine, Dept. WOJJ10,
P.O. Box 5135, Buffalo, NY 14205-5135
- Allow 4-6 weeks for delivery
- This card expires November 18, 2010

Ask WOOD

Answers to your questions from letters, e-mails, and WOOD Online®

HAVE A QUESTION?

For an answer to your woodworking question, write to **ASK WOOD**, 1716 Locust St., LS-221, Des Moines, IA 50309-3023, or e-mail us at askwood@woodmagazine.com. For immediate feedback from your fellow woodworkers, post your questions on one of our woodworking forums at woodmagazine.com/forums.

Rainbow Eucalyptus: Look, but don't cut

Q: On a vacation in Hawaii, I ran across the Rainbow Eucalyptus—an incredible tree with multi-colored bark. Does the coloration carry through to the wood inside and, if so, is it suitable for woodworking projects?

—Paul Tanenbaum, Columbus, Ohio

A: The Rainbow Eucalyptus (*Eucalyptus deglupta*) is indeed a striking tree, Paul. According to LariAnn Garner, plant physiologist with Aroidia Research in Florida City, Fla., the variegated coloring of this tropical species is limited to the smooth, layered, and constantly exfoliating bark. Newly exposed, the bark starts as bright green, and as it ages, it turns to dark green, blue, purple, pink-orange, and finally red-brown before peeling off in strips to reveal fresh green underneath. This gives the trunk a colorful, ever-changing look, shown at *right*.

But beneath the Technicolor bark, the wood looks and works like most members of the Eucalyptus family: hard, with an even, close grain; light in color, aging to a reddish-brown. But no rainbow tone. Given its limited growing range, the Rainbow Eucalyptus is too rare to be considered as a source of woodworking wood. If you're interested in working with eucalyptus, consider Jarrah, a versatile Australian eucalyptus that resembles mahogany or teak. Or ask your hardwood dealer about Lyptus, a low-cost eucalyptus hybrid that imitates cherry and mahogany. Marketed by Weyerhaeuser, Lyptus grows in sustainable plantations and has increased in availability.

The ever-changing color of the Rainbow Eucalyptus' layered, shedding bark is best enjoyed in its living tree form.

continued on page 84



Photo courtesy: LariAnn Garner, Aroidia Research

HARBOR FREIGHT TOOLS

Quality Tools at Ridiculously Low Prices

FACTORY DIRECT TO YOU!

How does Harbor Freight Tools sell high quality tools at such ridiculously low prices? We buy direct from the factories who also supply the major brands and sell direct to you. It's just that simple! Come see for yourself at one of our 330 STORES NATIONWIDE and use this 20% OFF Coupon on any of our 7,000 products. We stock Automotive products, Shop Equipment, Hand Tools, Tarps, Compressors, Air & Power Tools, Material Handling, Woodworking Tools, Welders, Tool Boxes, Outdoor Equipment, Generators, and much more.

NOBODY BEATS OUR QUALITY, SERVICE AND PRICE!

- ✓ We Have 10 Million Satisfied Customers
- ✓ We Buy Factory Direct and Pass the SAVINGS on to YOU!
- ✓ Shop & Compare Our Quality Brands Against Other National Brands
- ✓ Thousands of People Switch to Harbor Freight Tools Every Day!
- ✓ NO HASSLE RETURN POLICY ✓ Family Owned & Operated

LIFETIME WARRANTY
ON ALL HAND TOOLS!

We Will Beat Any Competitor's Price Within 1 Year Of Purchase!

330 STORES NATIONWIDE

TO FIND THE STORE NEAREST YOU OR BUY ONLINE:
HarborFreight.com/Wood
or call 1-800-657-8001

SUPER COUPON!

20% OFF

ANY SINGLE ITEM!

Bring this coupon and Save 20% on one single item purchased at Harbor Freight Tools. Cannot be used with any other discount or coupon. One coupon per customer. Coupon not valid on prior purchases or purchase of gift cards or purchase of extended service plans. Offer good on in-stock merchandise only. Savings discount percentage off Harbor Freight Tools current prices, including sale prices. This coupon cannot be duplicated in any manner including photocopies and computer printouts. Original coupon must be presented in order to receive the discount. All Campbell Hausfeld products are excluded from this offer. This offer is not valid on food or beverage items sold in our retail stores. Valid only in Retail Stores through 9/18/10.



10401818

See HarborFreightusa.com/Wood for additional SUPER COUPONS

SUPER COUPON!

LOT NO. 97080

CENTRAL PNEUMATIC

1/3 HP, 3 GALLON, 100 PSI OILLESS AIR COMPRESSOR

\$39⁹⁹

REG. PRICE \$69.99



SAVE 42%



33926601

HARBOR FREIGHT TOOLS - LIMIT 1
These valuable coupons are only good when presented at your nearest Harbor Freight Tools store. Offer Ends 9/18/10. Coupons valid in Retail Store Only. Coupon not valid on prior purchases. Coupon cannot be bought, sold, or transferred. This coupon cannot be duplicated in any manner including photocopies and computer printouts. Original coupon must be presented in order to receive the discount.

SUPER COUPON!

LOT NO. 67256

MULTIFUNCTION POWER TOOL

CHICAGO Electric Power Tools

SIMILAR TOOLS SOLD NATIONALLY AT \$400!



SAVE 41%

\$34⁹⁹

REG. PRICE \$59.99



69038354

HARBOR FREIGHT TOOLS - LIMIT 1
These valuable coupons are only good when presented at your nearest Harbor Freight Tools store. Offer Ends 9/18/10. Coupons valid in Retail Store Only. Coupon not valid on prior purchases. Coupon cannot be bought, sold, or transferred. This coupon cannot be duplicated in any manner including photocopies and computer printouts. Original coupon must be presented in order to receive the discount.

SUPER COUPON!

LOT NO. 93012

CENTRAL MACHINERY

16" VARIABLE SPEED SCROLL SAW

\$49⁹⁹

REG. PRICE \$79.99

SAVE 37%



73941106

HARBOR FREIGHT TOOLS - LIMIT 1
These valuable coupons are only good when presented at your nearest Harbor Freight Tools store. Offer Ends 9/18/10. Coupons valid in Retail Store Only. Coupon not valid on prior purchases. Coupon cannot be bought, sold, or transferred. This coupon cannot be duplicated in any manner including photocopies and computer printouts. Original coupon must be presented in order to receive the discount.

SUPER COUPON!

LOT NO. 95082

CENTRAL MACHINERY

2-1/2 HP 12" PLANER WITH DUST COLLECTION

REG. PRICE \$199⁹⁹

\$249.99

SAVE \$50



87023461

HARBOR FREIGHT TOOLS - LIMIT 1
These valuable coupons are only good when presented at your nearest Harbor Freight Tools store. Offer Ends 9/18/10. Coupons valid in Retail Store Only. Coupon not valid on prior purchases. Coupon cannot be bought, sold, or transferred. This coupon cannot be duplicated in any manner including photocopies and computer printouts. Original coupon must be presented in order to receive the discount.

SUPER COUPON!

CENTRAL MACHINERY

OSCILLATING SPINDLE SANDER

LOT NO. 95088

REG. PRICE \$149.99

\$79⁹⁹

SAVE \$70



60782711

HARBOR FREIGHT TOOLS - LIMIT 1
These valuable coupons are only good when presented at your nearest Harbor Freight Tools store. Offer Ends 9/18/10. Coupons valid in Retail Store Only. Coupon not valid on prior purchases. Coupon cannot be bought, sold, or transferred. This coupon cannot be duplicated in any manner including photocopies and computer printouts. Original coupon must be presented in order to receive the discount.

SUPER COUPON!

5" RANDOM ORBITAL PALM SANDER

CHICAGO Electric Power Tools

\$16⁹⁹

REG. PRICE \$29.99

SAVE 43%



LOT NO. 93431

HARBOR FREIGHT TOOLS - LIMIT 1
These valuable coupons are only good when presented at your nearest Harbor Freight Tools store. Offer Ends 9/18/10. Coupons valid in Retail Store Only. Coupon not valid on prior purchases. Coupon cannot be bought, sold, or transferred. This coupon cannot be duplicated in any manner including photocopies and computer printouts. Original coupon must be presented in order to receive the discount.

SUPER COUPON!

LOT NO. 113/91753

CENTRAL PNEUMATIC

HIGH SPEED METAL SAW

\$9⁹⁹

REG. PRICE \$29.99

SAVE 66%



Item 113 shown



77410827

HARBOR FREIGHT TOOLS - LIMIT 1
These valuable coupons are only good when presented at your nearest Harbor Freight Tools store. Offer Ends 9/18/10. Coupons valid in Retail Store Only. Coupon not valid on prior purchases. Coupon cannot be bought, sold, or transferred. This coupon cannot be duplicated in any manner including photocopies and computer printouts. Original coupon must be presented in order to receive the discount.

SUPER COUPON!

Pittsburgh

Item 38082 shown

LIFETIME WARRANTY

6 PIECE PLIERS SET

LOT NO. 38082/46005

\$7⁹⁹

REG. PRICE \$14.99

SAVE 46%



52762135

HARBOR FREIGHT TOOLS - LIMIT 1
These valuable coupons are only good when presented at your nearest Harbor Freight Tools store. Offer Ends 9/18/10. Coupons valid in Retail Store Only. Coupon not valid on prior purchases. Coupon cannot be bought, sold, or transferred. This coupon cannot be duplicated in any manner including photocopies and computer printouts. Original coupon must be presented in order to receive the discount.

Best-Ever Plans for Your Yard or Patio

from the editors of **WOOD** magazine

See **1,200+** woodworking plans at woodmagazine.com/plans



Arbor
Plan DP-00328a \$3.00



Grand Entrance Garden Gate
Plan DP-0322 \$6.75



Good-Neighbor Fence
Plan DP-00323a \$3.50



Terrific Trellis
Plan DP-00330a \$3.00



Tree Bench
Plan DP-00612 \$9.95



Patio Perfect Planter
Plan DP-00265 \$5.95



Outdoor Bench
Plan DP-00221 \$7.95



Adirondack Chair & Footstool
Plans DP-00197 \$8.95



Easy Glider
Plan DP-00305 \$8.95



Arched Trellis
Plan DP-00458 \$6.95



Step-by-Step Plant Stand
Plan DP-00545a \$3.00



Potting Bench
Plan DP-00193 \$7.95



Comfy Classic Bench
DP-00512 \$9.95



Fun-in-the-Sun Picnic Table
Plan DP-00723 \$11.95



Freestanding Planter Box
Plan DP-00503 \$4.00



Trellised Arbor
Plan DP-00263 \$5.95



Flower Tuteur
Plan DP-00185 \$5.95



Arched Garden Bridge
Plan DP-00139 \$8.95



Mailbox Planter
Plan DP-00195 \$5.95



Garden Bench Trellis
Plan DP-00542a \$4.95



Bistro Patio Table and Stools
Plan DP-00549 \$7.95



Server with Bar Stools
Plan DP-00586 \$7.95



Lazy-Days Chaise
Plan DP-00258 \$5.95



Garden Bench
Plan DP-00362 \$5.95



Garden Arbor Getaway
Plan DP-00394 \$5.75

Download any of these woodworking plans for the prices listed, or view a larger image, at woodmagazine.com/plans
For paper plans mailed to you (add \$3 per plan plus S+H), call **toll-free 1-888-636-4478**. Please have your credit card available. AD WD0710

A BIG ASS FAN FOR MY SHOP?



ABSOLUTELY!

You've got this great shop with high ceilings. It's too hot in the summer and too cold in the winter. The solution is the all new ShopFan™ from Big Ass Fans®, engineered with our patented airfoil technology to improve conditions in workshops up to 5000 square feet.



The monthly operating cost of a ShopFan is less than a dollar per month...yet it does the work of more than twenty standard ceiling fans. It's an investment that will pay dividends for a lifetime.

QUIRKY NAME. SERIOUS FANS.

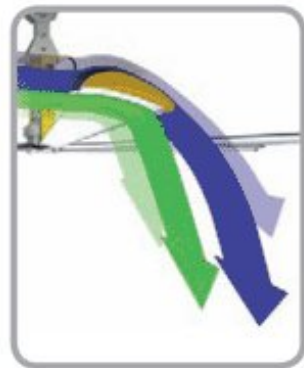

For over a decade, Big Ass Fans has been engineering large, high-performance ceiling fans for tens of thousands of satisfied industrial customers worldwide. Like all of our fans, ShopFan is engineered, precision balanced and hand built with aircraft-grade aluminum and industrial components right here in Lexington, Kentucky. You can have this fan up and running in a couple of hours. And best of all, it's a genuine Big Ass Fan.

**TRY A SHOPFAN IN YOUR SHOP
FOR 30 DAYS
CONTACT US FOR DETAILS
877-326-0599
WWW.BIGASSFANS.COM**

Truly A Big Ass Fan

- High Volume/Low Speed air movement technology
- Industrial ceiling fan quality

Easy Installation

- Weighs less than 140 lbs
- Pre-wired for 115V 20A operation
- Includes 50-ft motor cord

Keeps Things Cool

- Improves employee comfort
- Increases productivity and accuracy

Sized for Small Shops

- Air circulation for spaces up to 40 ft x 40 ft
- Fits ceilings as low as 14 ft
- 12-ft diameter fan

Full-featured Controls

- Fully adjustable speed settings
- Compact control unit is pre-wired

Year-round Energy Savings

- Low energy air circulation
- Provides cooling breezes in summer
- Gently pushes warm air down in winter

 **BIG ASS FANS®**
877-BIG FANS | WWW.BIGASSFANS.COM
An ISO 9001:2000 certified company
No Equal.

May be covered by one or more of the following U.S. Patents: 6,244,821; 6,589,016; 6,817,835; 6,939,108; 7,252,478; 7,284,960; D587,799; D607,988 and other patents pending.

©2010 Delta T Corporation dba The Big Ass Fans Company. All rights reserved.

For the **ultimate** in
dust collection,
 harness the **power** of a
cyclone.



The cyclonic
 action of our
 award-winning
 products
 whirls away
 dust for health,
 safety and
 easy cleanup.

Serious woodworkers everywhere are breathing easier – and cleaning up in a snap – with our Pro Series Dust Collection System. This revolutionary system delivers the dust-free work environment you've always wanted. Custom engineered to fit seamlessly into your shop.

"One of the best
 investments I ever made.
 I thank you, and more
 importantly, my lungs
 thank you."

— John Sasso
 Colorado

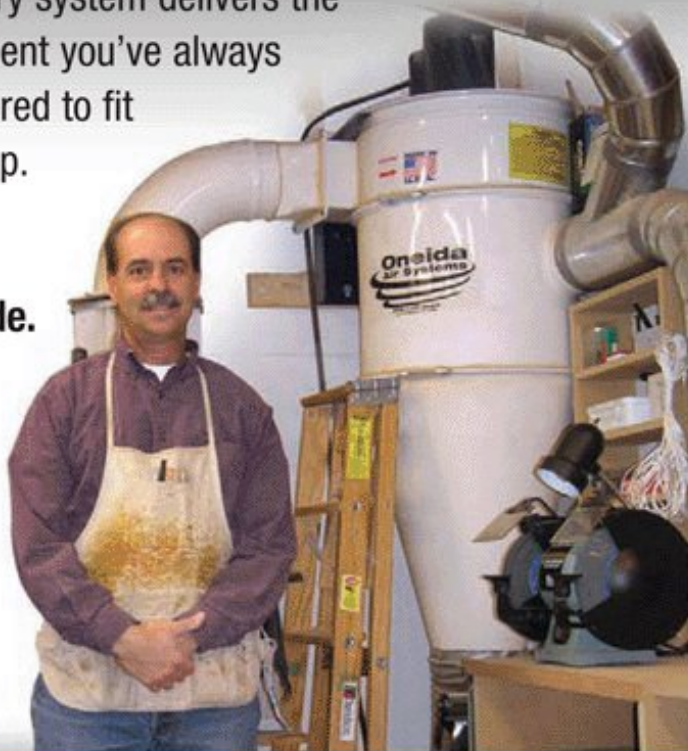

 Made in USA

Order Online at
oneida-air.com

Call for your FREE catalog!
800.732.4065



Ask WOOD

Sprung joint: Your last layer of moisture defense

Q: One of the glued-up shelves that I built split along the glue-line at the shelf's ends. The shelf is floating, so there's nothing restraining seasonal movement. What should I do to prevent this?

—Lanny Cunningham, Dallas

A: Sounds like the boards of the shelf are pulling against themselves, Lanny. This sometimes happens because the ends of the shelf absorb and shed moisture more easily than the interior, thus swelling or—as in your case—shrinking at a disproportionate rate.

One preventative solution that the old-timers used was a "sprung" joint. Both boards of a sprung joint have slightly concave mating edges.

To create a sprung joint, first joint the mating edges as you normally would. Pair the boards in your bench vise with their ends and top edges flush. With a hand plane, make a light pass over the center two-thirds of the boards' edges. Then make two full passes to smooth the edge into an arc about 1/32" deep.

Dry assemble the boards. Only the ends should be touching with a gap in the center where you formed the arcs. When you glue the boards together, clamp from the center outward, ensuring that the joint pulls tight and leaves no trace of the gap. Now the ends can shrink without forcing the glue line to separate. 🌲

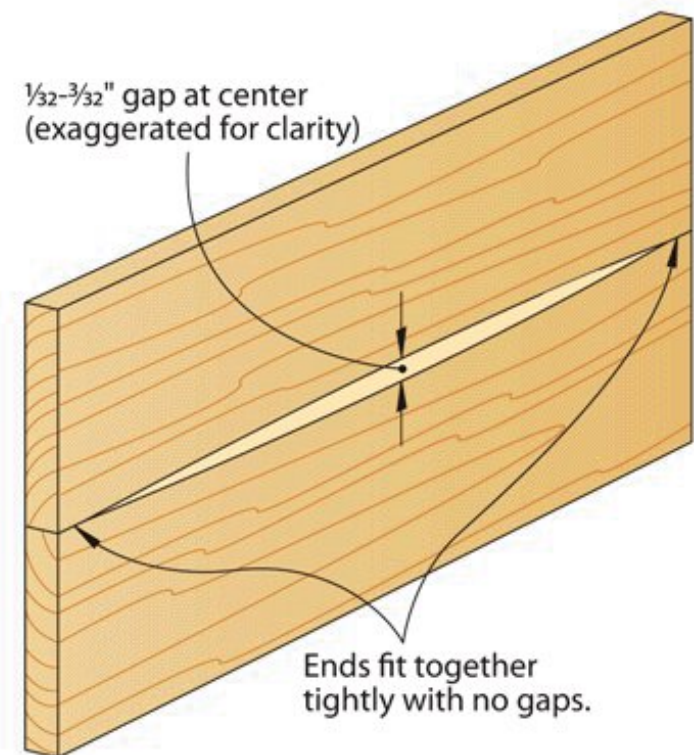
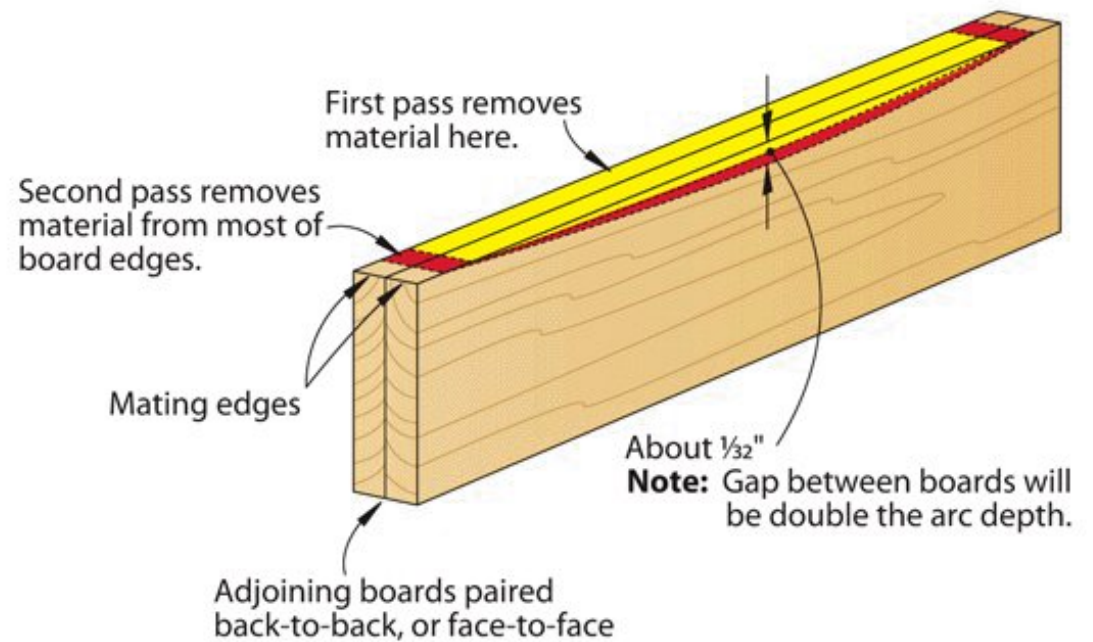

LIMITED-TIME BONUS - \$50 SAVINGS CARD*

Relieve Back Pain

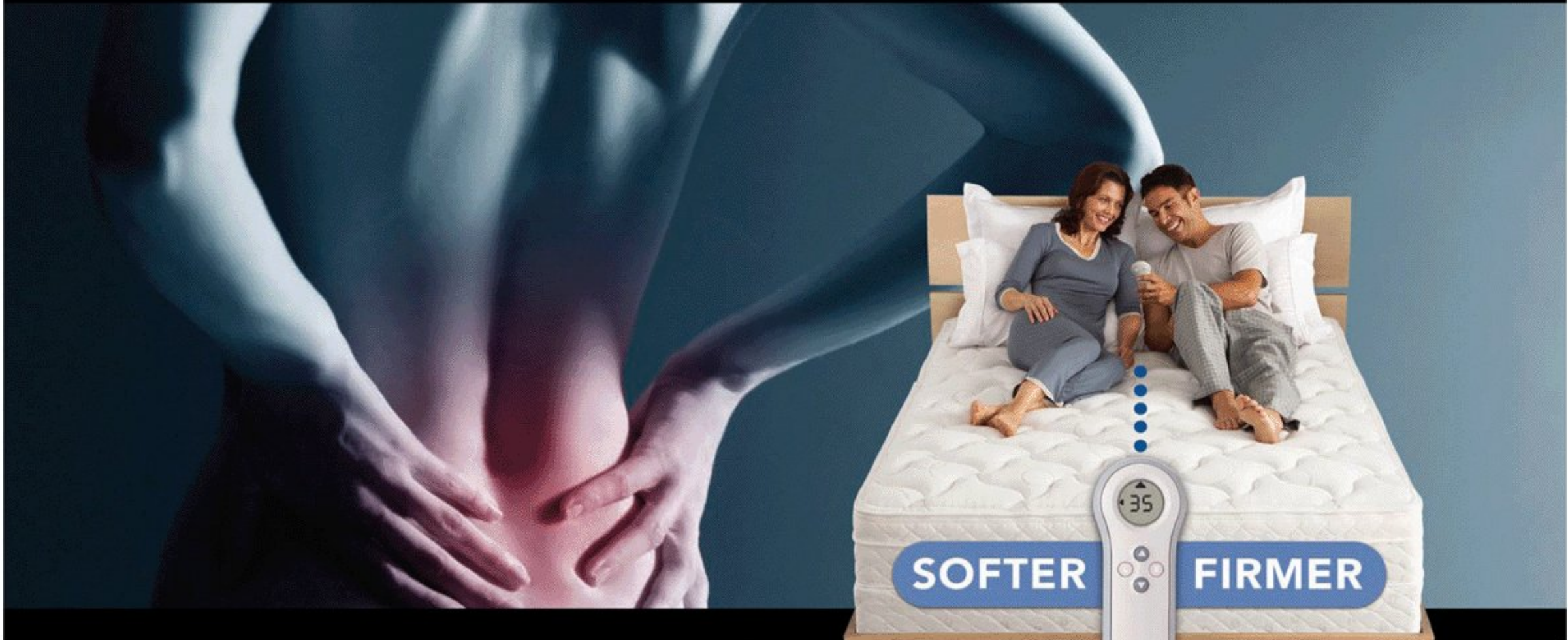

Our owners say it. Science proves it.

Over 6 million people own a SLEEP NUMBER® bed. Not surprisingly, many of them say they would never go back to an ordinary mattress. Recent studies show why.

93% Experienced back-pain relief†

In independent clinical studies, nearly all participants with back pain who switched to a Sleep Number bed experienced less pain.

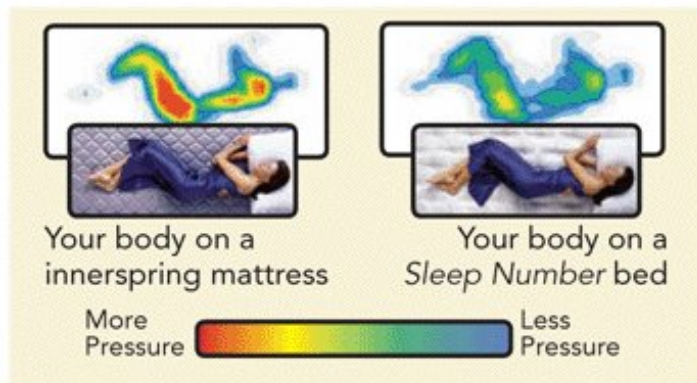

89% Reported improved sleep quality

In research conducted at Stanford and Duke Universities, subjects fell asleep faster, spent less time awake in bed and experienced a better quality of sleep on the Sleep Number bed.

sleep number
by SELECT COMFORT

*Restrictions apply. See Savings Card for details and expiration date. †Descriptions of clinical studies on the Sleep Number bed are available by calling 1-800-831-1211. ‡If not satisfied after 30 nights, call within 45 days of delivery to arrange return. We'll reimburse the purchase price less your initial shipping or Home Delivery and Setup fees. You pay return shipping. No returns or exchanges on Precision Comfort® Adjustable Base, close-out or demo bed models.
© 2010 Select Comfort



FIRMNESS ADJUSTS ON EACH SIDE

77% Discovered increased energy

Study participants also reported increased vitality after sleeping on a Sleep Number bed compared to their own innerspring mattresses.

Try it for 30 nights, RISK FREE†

We're so sure you'll sleep better, you can take up to one month to decide, or your money back!‡ You've got to sleep on it to believe it!



LIMITED-TIME BONUS OFFER

Purchase any Sleep Number bed or accessory items of \$100 or more and receive \$50 off.*



CALL TODAY TO LEARN MORE:
1-800-831-1211 ext 39113
sleepnumber50.com



YES! PLEASE RUSH MY FREE

- Limited-Time Bonus Offer \$50 Savings Card*
- Free Brochure and DVD

Name _____

Address _____

City _____ State _____ Zip _____

Phone # _____ Email _____

Mail to: Select Comfort, 9800 59th Avenue North,
Minneapolis, MN 55442-9971 ext 39113

Shop-Proven Products

These woodworking wares passed our shop trials

About our product tests

We test hundreds of tools and accessories, but only those that earn at least three stars for performance make the final cut and appear in this section. Prices are current at the time of article production and do not include shipping, where applicable.

Riving knife adds safety to contractor saw

Grizzly's G0661 tablesaw breaks the contractor-style-tablesaw mold with a motor that mounts below the blade instead of hanging out the back. Also, the motor moves with the blade arbor up and down on a lead screw. This enables its riving knife to move up and down with the blade while staying just below the arc of the blade, allowing you to cut rabbets or tenons without the blade guard/splitter assembly.

The saw's 2-hp-rated, 110-volt motor plowed the blade through every tough task I threw at it—such as bevel-ripping 2"-thick white oak—without hesitation. The T-square-style rip fence has smooth and straight aluminum sideboards, red hairline cursors on the left and right sides, and a solid lock. Another nice feature: You can adjust the 0° and 45° blade-bevel stops via two screws recessed into the cast-iron top. No more fumbling inside the guts trying to adjust bolts.

I like the shroud around the blade that corralled most of the dust, but its 2½" port underneath the saw proved difficult to reach and attach a hose.



—Tested by Doug Hicks,
a former shop teacher and
woodworking magazine editor



Contractor-style tablesaw, #G0661

Performance	★★★★★
Price	\$850
Grizzly Industrial 800-523-4777; grizzly.com	

Low-cost miter gauge delivers 120 dead-on stops

Most stationary tablesaws come with a no-frills, three-stop miter gauge that's adequate, but leaves me wanting more. Unfortunately, many elaborate, aftermarket upgrades cost \$150 or more to gain precision at every angle. Enter Incra's mid-priced V120 miter gauge that provides 120 spot-on angle settings, with notches for all whole-number degrees between 61° left and right. (There are no notches for 22° and 23° on either side to allow for a notch at 22½°.) A protractor confirmed the accuracy of every setting at which I made a cut. That's worth the price right there.

Adding to its value are nylon adjusters on the bar with top-adjusting screws to quickly snug up the fit in the miter slot, as well as a removable T-slot clip. And with a slippery-smooth plastic plate underneath the head, the V120 glides across cast-iron tops. Slots in the head's face make it easy to attach an auxiliary fence.

—Tested by Craig Ruegsegger, Multimedia Editor



Miter gauge, #V120

Performance	★★★★★
Price	\$75
Inkra Precision Tools 972-242-9975; incra.com	

continued on page 88



Found! The Last Morgan Silver Dollars

Amazing Discovery Hidden in Midwest Farm Cellar

Indiana. A farmer in America's heartland recently cashed in his long-forgotten savings, hidden away for decades in a dusty crate in his cellar—a hoard of the last Morgan Silver dollars minted by the U.S. Treasury before they ceased production for good, in 1921.

Originally purchased from a local bank for face value, the farmer had tucked them away for his retirement. Now these glittering chunks of nearly uncirculated silver history, are being released to the public by GovMint.com. While they last, you can acquire these brilliant, lustrous silver coins for as low as \$29.50 apiece. Twenty-coin Bankers rolls and 10-coin Half Rolls are available.

Survival Against All Odds

By all rights these silver dollars should have been destroyed decades ago. Government silver melt-downs, including the 1918 Pittman Act, which alone destroyed 270 million Morgans, have decimated supplies. Millions more were called in by the government and melted for their silver content between 1921 and 1965. Today private hoards account for virtually all the surviving coins. And of those, only a fraction survive in the Virtually Uncirculated condition so coveted by collectors.

Prized Last Year Coins

These last year 90% pure silver beauties still dazzle with their Mint luster and heft. Weighing in at 26.73 grams and a diameter of 38.1 mm, they are the largest American silver coins ever to circulate. Struck from silver mined from the western Mother Lode, they are the legendary coins that built the West. Master engraver George T. Morgan fashioned a radiant profile of Lady Liberty and a majestic eagle as symbols of our nation's strength and prosperity. Today, the long-gone Morgan silver dollars are among the most sought-after coins in America.

Hot Silver Market, Hot Silver Value

Silver prices have jumped over 140% in the last two years fueling the frenzy among avid collectors, investors, and the 130 million new collectors created by the U.S. Mint's highly successful state quarters program.

Today, the market is hot for Silver coins in any condition. This same 1921 Morgan Silver Dollar currently sells elsewhere in the same grade condition for \$55 apiece. But while supplies last you can get this original Virtually Uncirculated 1921 Silver Morgan for as little as \$29.50 each, in quantity!

Money-Back Satisfaction Guarantee

You must be 100% satisfied with your order, simply return it within 30 days via insured mail for a prompt refund of the complete purchase price.



Originally U.S. Silver Dollars were minted and stored in 1,000-coin canvas bags by the Mint.

Last 1921 Morgan Silver Dollar \$39 plus S&H

Buy More and Save

FIVE 1921 Last Morgan Silver Dollars
\$170.00 plus S&H **Save \$25!**

TEN 1921 Last Morgan Silver Dollars
\$315.00 plus S&H **Save \$75!**

20-COIN ROLL of 1921 Last Morgan Silver Dollars
\$590.00 plus S&H **Save \$190!**



Toll-Free 24 hours a day
1-800-973-3039

Promotional Code LMD193
Please mention this code when you call.



We can also accept your check by phone.
To order by mail call for details.

GOVMINT.COM
YOUR ONE BEST SOURCE FOR COINS WORLDWIDE

14101 Southcross Drive W., Dept. LMD193
Burnsville, Minnesota 55337

www.govmint.com

Note: GovMint.com is a private distributor of government and private coin and medallion issues and is not affiliated with the United States Government. © GovMint.com, 2010

Prices subject to change without notice.
Past performance is not an indicator of future performance.



Warm to the comfort of radiant heat

RADIANT

Floor Company

Efficient, Quiet, Reliable

It's never been easier to do it yourself

compatible
with any fuel source:

GAS, PROPANE
SOLAR, OIL, WOOD
ELECTRIC,
GEOTHERMAL



VISIT OUR WEBSITE
CALL FOR A FREE QUOTE
www.radiantcompany.com

Barton, Vermont
(toll free) 1.866.WARM-TOES (927.6863)

WOODCRAFT®

For A Free Catalog Or To Find Your Local Woodcraft Store, Visit woodcraft.com Or Call 800-225-1153.

Advanced GRR-Ripper® System

The Gripper is a revolutionary, universal pushing jig for all table saw, router table and jointer users. This is the first tool that grips and holds both sides of a workpiece during a ripping operation. Unlike a pushstick or pushblock, the Gripper maintains balanced pressure on a workpiece as it passes through and beyond the blade.

- Maintains a parallel, forward direction with the blade while keeping pressure against your rip fence to prevent burning
- Eliminates the need to feed stock with your bare hands providing 100% protection
- You can cut strips as thin as 1/4" without any special setup, so there is no need to throw away those small scrap pieces
- The unit can be offset to accommodate small, irregular shaped pieces on the router table
- Includes main body, handle, 1/4" side leg, 1/2" side leg, center leg, adjustable spacer, stabilizing accessory plate, balance support and comprehensive user's manual



820434

10WI07R

QUALITY WOODWORKING TOOLS • SUPPLIES • ADVICE®

Shop-Proven Products

Pivoting Quick-Grips make clamping curves easier

I build a lot of free-form (curving) furniture that proves hard to clamp at times. So I really appreciate Irwin's Quick-Grip bar clamps with pivoting jaws. With these I saved time by not making one-time-use curved cauls to accommodate my regular clamps.

Irwin's clamps couldn't be simpler to use: Just slide the lock and the jaws pivot 3° up and 12° down. Then tighten the clamp and it automatically adjusts to the project shape.

The blue-and-silver XP600 clamps, shown below, have two pivoting jaws. They also come with removable 90° fixed jaw pads that extend to the bar. These brutes are nearly twice as heavy as the blue-and-yellow SL300 clamps (not shown). With 1/2" less throat depth, the SL300 clamps have only one pivoting jaw and don't come with the long jaw pads. Both models come in 6, 12, 18, 24, and 36" lengths; the XP600s also come 50" long.

—Tested by Matt Seiler,
a custom-furnituremaker



One-hand bar clamps, #SL300/XP600

Performance	★★★★★
Price	SL300: \$20-\$40 per clamp XP600: \$25-\$60 per clamp
Irwin Industrial Tools 800-464-7946; irwin.com	



www.logosol.com
1-877-564-6765



M7 Chainsaw Mill. The easiest, most versatile, and economic way to cut quality boards.

2-Year Warranty.
60-Day Money-back Guarantee.

State-of-the-Art Website,
Success Stories, Forum, Technical Specs,
How-to Info, Pricing and More.

PH260. The original, superior quality 4-sided planer/moulder.



LOGOSOL
SOLUTION DRIVEN WOOD PROCESSING

Turn to Quality



Shop on-line
@
↓

www.hutproducts.com
1-800-547-5461

HUT
Products

STEEL BUILDINGS
MADE IN THE USA!
Summer Sale!



30 YEAR WARRANTY



up to 50% savings!



AMERICAN STEEL SPAN www.steelspan.com

800-891-6733 ext 018

FINAL CUT
All in one step...Just cut, the sanding is a bonus

Compare: See how Final Cut



Cuts and Sands at the Same Time

866-305-0219 toll free
www.finalcutblade.com

WWW.RADARCARVE.NET
Wood Carving Duplicators

- Furniture
- Gunstocks
- Millwork
- Decoys
- Musical Instruments

Incredibly accurate



Thousands of Uses 505-948-0571

TURN TO PACKARD FOR QUALITY TURNING TOOLS AND SUPPLIES

"Holly Finial Box" - Cindy Drozda



1-800-683-8876
PACKARDWOODWORKS.COM

Packard WOODWORKS INC.
The Woodturner's Source

Knifemaking Made Easy!
Cutlery Blades

Traditional style blades assist the woodworker in creating a set of knives to be appreciated for a generations to come!

Complete set includes 11 blades shown, rivets, Dymondwood and instructions:
SS801.....\$74.95

Over 300 blades and kits available
Knife making kits, Exotic Woods, Horn, Pearl, Ivory, Abrasives, Finishing Supplies, Schrimshaw kits, Leathercraft Supplies, Books, Videos, And More!

JANTZ SUPPLY
309 WEST MAIN - DAVIS OK 73030
Full Color Catalog (\$5.00)
1-800-351-8900
www.knifemaking.com



Your Source for Wood
Lumber • Veneer • Turning Stock
Domestic & Exotic

800.423.2450



WOODWORKERS Source

Over 100 beautiful woods.
Secure online ordering.

www.101woods.com



Can Your Old Dust Collector Work Better Than A New One?



Cyclones, Stand-Alones, Baghouses & more

Yes, With Optimized Filters From...



- Optimum Performance
- Low Maintenance
- Custom Designs
- Cleaner Air
- Longer Life
- Economical
- Best Size & Fit
- Proudly Made In USA

IWF Visit us at Booth #1873
2010

We Design & Fabricate Custom Filter Bags That **REALLY WORK!**

American Fabric Filter Co.
(800) 367-3591 americanfabricfilter.com

Moisture Meters

Fine Woodworking Magazine highly recommended the Ligno-Scanner D:

Pinless measurement, accuracy, built-in corrections for different wood species and ease of operation were the main criterias.

2 Year Warranty.

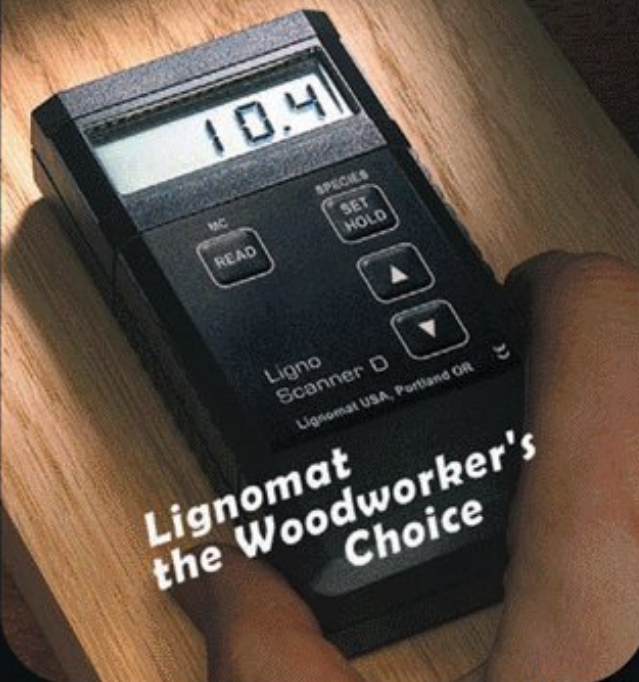

Lignomat the Woodworker's Choice

Lignomat USA LTD
800-227-2105

www.lignomat.com
E-mail: sales@lignomat.com

AUTHOR'S BEST OVERALL CHOICE

Fine Woodwkg
Jan/Feb 10
page 67

STOP BUYING LUMBER!

Use your chain saw and Granberg's mill to create perfect slabs of wood

- 1. MKIII Attachment**
Easily Mounts on Bar
Sizes from 24" to 56"
- 2. MINI MILL Attachment**
Great partner for MKIII
Ideal for edging, and reducing log diameters
- 3. SMALL LOG Attachment**
Add to chain saw and start making lumber!

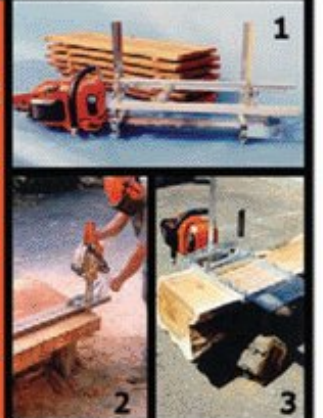

WWW.GRANBERG.COM
CALL NOW FOR FREE CATALOG! 800-233-6499
50 Years of Customer Satisfaction!

DETAILED Play Systems Backyard Playground Equipment

FREE CATALOG!

Just Add Lumber!

FREE SMILES!

Do it Yourself and Save!
www.detailedplay.com
1-800-398-7565

CLAMP EDGE™ WIDE TRACK

BORA™ TOOL GUIDE
AFFINITY TOOL WORKS, LLC
(866) 588-0395 • www.affinitytool.com

Make Time!
Create your own wooden gear clock!

Order the pattern or the complete kit. Build it your way!

Wooden-Gear-Clocks.com
clocks, kits, and do-it-yourself patterns
715-955-4104
www.wooden-gear-clocks.com

WOOD HEAT CLASSIC
Outdoor Wood Furnace

- Heat your entire home, multiple buildings along with water, and more.
- Adapts easily to new or existing heating systems.
- There is no safer, more convenient way to heat with wood.

Central Boiler
Find your nearest dealer at:
CentralBoiler.com
800-248-4681
©2010 Central Boiler ad5561

EXCLUSIVE!

INFINITY™ CUTTING TOOLS

Carbide & HSS Knives

DEWALT DW735 PLANER

- ✓ Thicker
- ✓ Stronger
- ✓ Lasts Longer From \$79.90

infinitytools.com | 877-USA-BITS

Best selection on the web!

- Hardwood Lumber
- Mouldings
- Flooring
- Plywoods
- Veneers

Moulding Catalog DOWNLOAD IT FREE

m.l. condon COMPANY Inc.

www.condonlumber.net
250 Ferris Avenue, White Plains, NY 10603
Phone: (914) 946-4111 • Fax: (914) 946-3779
email: mlc@mlcondon.com

SPINDLE ARM MORRIS NATIONAL AWARD WINNING DESIGN

Introducing the finest plan on the market today! This design has won awards across the country! Pages of directions and 36 by 48 CAD generated plan.

Plan #182

FREE CATALOG

AMERICAN FURNITURE DESIGN
P.O. BOX 300100 ESCONDIDO, CA 92030
SPINDLE ARM MORRIS PLAN \$19.95 +\$5.00 S&H
760 743-6923
www.americanfurnituredsn.com

U-BILD.COM



On-line catalog pictures hundreds of full-size woodworking plans at low prices, plus more than 30 downloadable plans. Indoor, outdoor, kids and holiday projects for all skill levels.

(800) 82-U-BILD

Get Into Wood
Sawing Lumber Made Easy!

MP-32 Sawmill Cut Wood For:
•Home •Barn •Fencing •Cabinets
•Stables •Decking and more...

5 Money Saving Package Deals!

FREE Catalog!
1-800-473-4804
www.cookssaw.com



WWW.PENMAKINGSUPPLIES.COM

Pen Kits, Pen Blanks, Finishing Products, Lathes, & More!



ORDER TOLL FREE
1-800-653-1930

Projects and Plans



Wheelbarrow

Kit to build includes 15" iron wheel that really works, axle and step-by-step plans. Finished project measures 66"L x 24"W x 26"H. \$39.95 plus S/H

ByeGone Workshop
888-279-3941 8-5 M-F EST
www.bye-gone.com

STEVE WALL LUMBER CO.
Quality Hardwoods and Woodworking machinery For The Craftsman and Educational Institutions

Ash	4/4	Select	\$ 2.60	UPS	\$ 94.00
Basswood	4/4	Select	\$ 1.95	Specials	\$ 80.00
Birch	4/4	Select	\$ 3.55		\$ 108.00
Butternut	4/4	1C	\$ 2.95		\$ 88.00
Cherry	4/4	Select	\$ 4.90		\$ 117.00
Hickory - Pecan	4/4	Select	\$ 3.00		\$ 100.00
Mahogany (Genuine)	4/4	Select	\$ 4.70		\$ 112.00
Maple (Hard)	4/4	Select	\$ 3.45		\$ 108.00
Maple (Soft)	4/4	Select	\$ 2.50		\$ 88.00
Poplar	4/4	Select	\$ 1.80		\$ 78.00
Red Oak	4/4	Select	\$ 2.70		\$ 96.00
Walnut	4/4	Select	\$ 4.90		\$ 115.00
White Oak	4/4	Select	\$ 2.70		\$ 96.00
Cedar (Aromatic Red)	4/4	1C+Btr.	\$ 1.80		\$ 78.00
Cypress	4/4	Select	\$ 2.60		\$ 90.00
White Pine	4/4	F.G.	\$ 1.25		\$ 70.00
Yellow Pine	4/4	Clear	\$ 2.30		\$ 82.00

Above prices are for 100' quantities of kilndried rough lumber sold by the Bd. Ft. FOB Mayodan, NC. Call for quantity discounts. Other sizes and grades available.

Above prices are 20 bd. ft. bundles of clear kilndried lumber 3"-10" wide • 3'-5' long (Random widths & lengths) Surfaced 2 sides or rough. Delivered UPS prepaid in the Continental U.S.

SEE OUR CATALOG ON THE WEB!

OLIVER MACHINERY DEALER

HARDWOOD PLYWOOD

CUSTOM RAISED PANEL DOORS

CUSTOM PLANK HARDWOOD FLOORING

THIN CRAFTWOOD

EXOTIC LUMBER

STEVE H. WALL LUMBER CO.

BOX 287
MAYODAN, N.C. 27027
336-427-0637
1-800-633-4062
FAX 336-427-7588

Email: wood@walllumber.com
Website: www.walllumber.com

Send \$1.00 For Lumber Catalog
Prices Subject to Change Without Notice

A Lilac that Reblooms!

A **WOOD** Magazine Exclusive Offer

Here's the perfect landscaping addition to compliment the Made-in-the-Shade Pergola on page 34 – a new reblooming lilac, "Bloomerang."™ Selected by the Better Homes and Gardens editors (our sister publication) as a favorite pick for 2010, this powerful lilac is covered in heavy clusters of purple-pink, sweetly scented blooms. The bush continues reblooming from May until the frost! Reaching just 4-5 feet tall, it is an excellent shrub for small spaces. Plant several together and create a fragrant hedge. They're ideal for cutting, because the blooms are abundant—plenty for inside and outside. Easy to grow, these long-lived shrubs are hardy in Zones 4-7. Shipped in 5" pots through October. One plant sells for \$19.95, or 3 plants for \$55.95 plus shipping.

To Order: call White Flower Farm, **800-420-2852**, or visit **WOODstore.net** Please specify MM767561 and source code WDSA1. Please order early; quantities are limited. Sorry, we are unable to ship to APO/FPO addresses, or outside the contiguous United States.



What's Ahead

Coming up in the September 2010 issue (on sale July 13)

Mission possible

Unless you tell them, no one will know those aren't real wedged tenons. Quick, easy, and invisible biscuit joinery holds together this quartersawn-white-oak classic piece. And don't let the angles throw you: One super-simple setup secret makes easy work of cutting every bevel and assembling the tapered case.



FEATURED PROJECT



Simple and slim hall table

No-fuss joints and home-center lumber help you add easy elegance to your entry hall.



TOOL TEST

Full bore ahead

No spin here: We test 9 workhorse floor-model drill presses and deliver the lowdown on which to buy.



Make your own built-ins

You'll be surprised how easy it is to design and install window seats and bookcases.



Power your way to a polished finish

Learn how to use readily available modern abrasives and power tools to bring your finish to a classy, glassy sheen.



Doozy of a 'dozer

Need to clear a roadway across the living room or knock down a tower of blocks? Then lower the blade and push ahead with the third toy in the Construction-Grade series.



Dust-catching sanding center

This cart not only helps collect dust, it gathers up the sanding supplies scattered around your shop.

The facts are hard to ignore.

Titebond® III outperforms polyurethane glues.

Reference Guide

Glue comparison

What woodworkers need to know!

	Titebond III	Polyurethane Glues
Higher Bond Strength	✓	✓
Exterior Use - Waterproof	✓	
Easy Water Cleanup	✓	
Much Safer To Use	✓	
Shorter Clamp Time	✓	
No Foam - Less Mess	✓	
Shorter Open Time	✓	✓
Doesn't Stain Skin	✓	✓
Bonds Most Materials	✓	
Bonds Oily / Exotic Woods	✓	
Lower Cost - Better Value	✓	
Longer Usable Shelf Life	✓	

Woodworking Handbook 2007



As the leader in wood glues, we want you to know the truth about polyurethane glue and woodworking. A straightforward comparison between Titebond® III Ultimate Wood Glue and polyurethane glue tells the story.

Titebond® III is THE ultimate choice for bonding wood to wood. Period.

For more information and a detailed comparison, please visit www.titebond.com/TBIIIvsPolyurethane

Made in the USA



THE PERFECT GIFT FOR THE MAN OF THE HOUSE



FatMax® Mobile Work Station



FatMax® 23" Structural Foam Tool Box



FatMax® 28" Structural Foam Tool Box



Visit StanleyGiftCenter.com

STANLEY® STORAGE MAKES THE PERFECT GIFT

What do you give the dad that already has too many tools? That's easy... he needs a place to store them. The Stanley® FatMax® line of Structural Foam Tool Boxes feature a host of rugged features including an air-tight water seal to keep out the elements, rust-proof metal latches for extended life, and thick structural foam walls for added durability.

STANLEY®

© 2010 Stanley Black & Decker, Inc.

www.WorldMags.net & www.Journal-Plaza.net